

Bridge Rectifiers

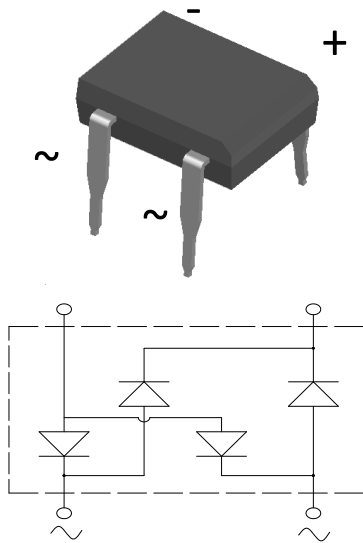

Features

- UL recognition, file #E313149
- High surge current capability
- Solder dip 275 °C max. 7 s, per JESD 22-B106

Typical Applications

General purpose use in AC/DC bridge full wave rectification for SMPS, lighting ballast, adapter, battery charger, home appliances, office equipment, and telecommunication applications.

Mechanical Data

- **Package:** DB
Molding compound meets UL 94 V-0 flammability rating, RoHS-compliant
- **Terminals:** Tin plated leads, solderable per J-STD-002 and JESD22-B102
- **Polarity:** As marked on body

■ Maximum Ratings (T_a=25 °C Unless otherwise specified)

PARAMETER	SYMBOL	UNIT	DF15005	DF1501	DF1502	DF1504	DF1506	DF1508	DF1510
Repetitive peak reverse voltage	V _{RRM}	V	50	100	200	400	600	800	1000
Average rectified output current @60Hz sine wave, R-load, T _a =40 °C	I _O	A	1.5						
Surge(non-repetitive)forward current @60Hz half sine wave, 1 cycle, T _j =25 °C	I _{FSM}	A	60						
Current squared time @1ms≤t≤3.3ms T _j =25 °C, Rating of per diode	I ² t	A ² s	15						
Storage temperature	T _{stg}	°C	-55 ~+150						
Junction temperature	T _j	°C	-55 ~+150						

■ Electrical Characteristics (T_a=25 °C Unless otherwise specified)

PARAMETER	SYMBOL	UNIT	TEST CONDITIONS	DF15005	DF1501	DF1502	DF1504	DF1506	DF1508	DF1510
Maximum instantaneous forward voltage drop per diode	V _F	V	I _{FM} =0.7A	1.00						
Maximum DC reverse current at rated DC blocking voltage per diode	I _{RRM}	μA	V _{RM} =V _{RRM}	5						

■ **Thermal Characteristics** ($T_a=25^{\circ}\text{C}$ Unless otherwise specified)

PARAMETER	SYMBOL	UNIT	DF15005	DF1501	DF1502	DF1504	DF1506	DF1508	DF1510
Thermal Resistance	$R_{\theta\text{-}A(1)}$	$^{\circ}\text{C}/\text{W}$	68.0						
	$R_{\theta\text{-}L}$		15.0						

Note
 (1) Thermal resistance from Between junction and ambient, On glass-epoxi substrate.

■ **Ordering Information (Example)**

PREFERRED P/N	PACKING CODE	UNIT WEIGHT(g)	MINIIMUM PACKAGE(pcs)	INNER BOX QUANTITY(pcs)	OUTER CARTON QUANTITY(pcs)	DELIVERY MODE
DF15005 ~ DF1510	B1	Approximate 0.39	50	2500	10000	Tube

■ **Characteristics (Typical)**

FIG1: I_o - T_a Curve

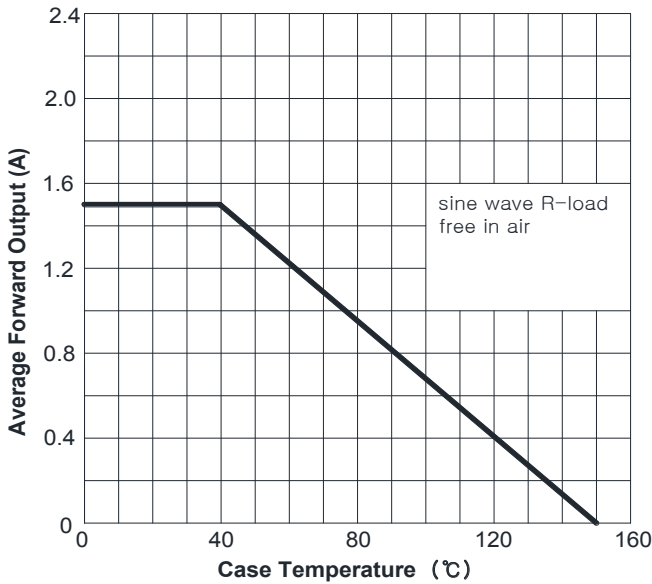

FIG2: Surge Forward Current Capability

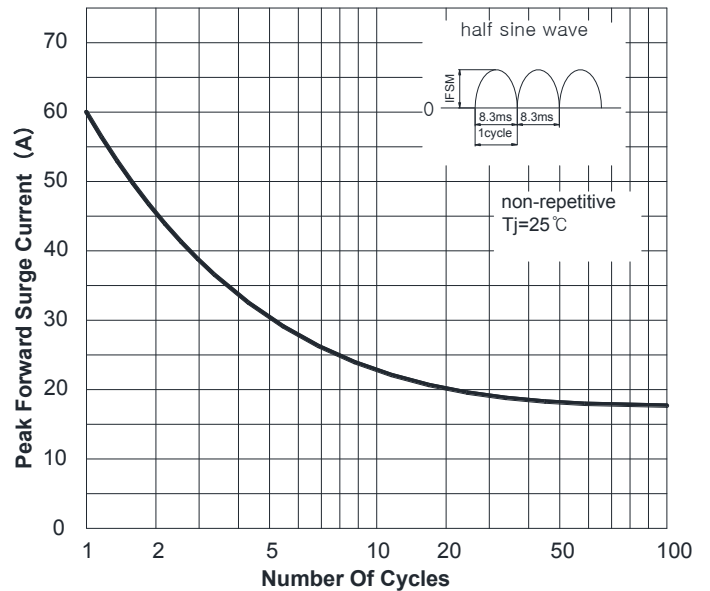

FIG3: Forward Voltage

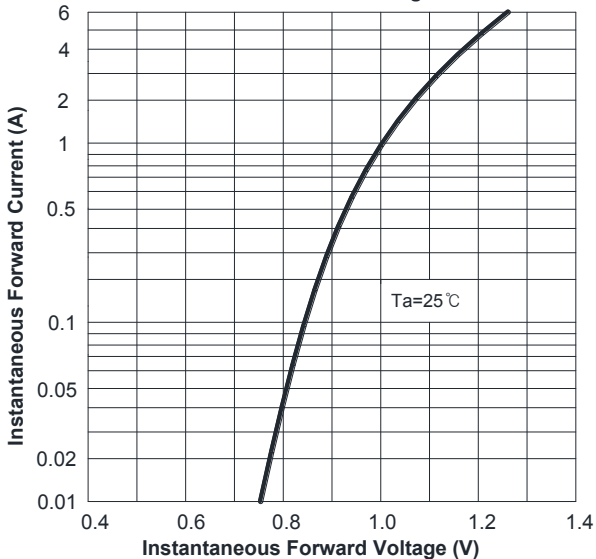
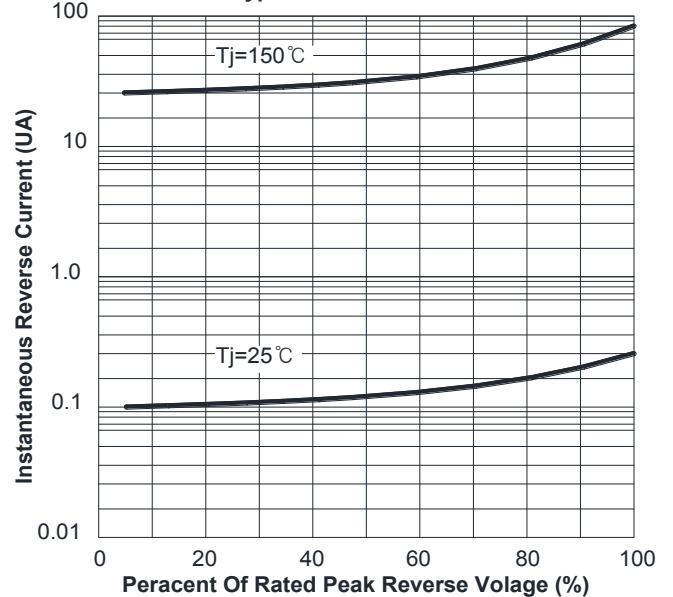
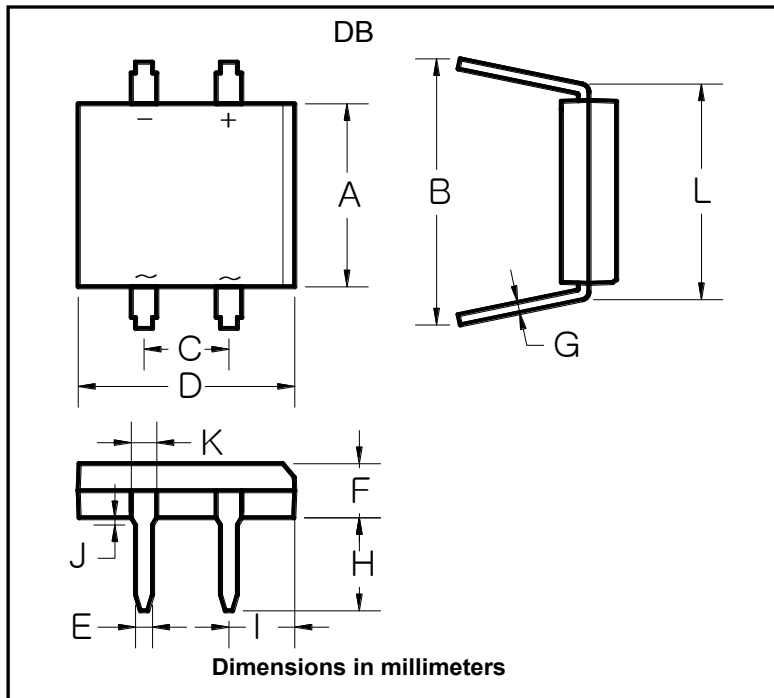

FIG4: Typical Reverse Characteristics



■ Outline Dimensions



DB		
Dim	Min	Max
A	6.20	6.50
B	7.60	8.90
C	5.00	5.20
D	8.13	8.51
E	0.46	0.58
F	2.80	3.30
G	0.22	0.33
H	3.81	4.69
I	1.39	1.90
J	1.27	2.03
K	0.89	1.14
L	7.24	8.00