



LED375-series



TECHNICAL DATA

UV LED

InGaN

LED375-series are InGaN LEDs mounted on a lead frame and encapsulated in various types of clear silicone lens, which offers different design settings.

On forward bias, it emits a radiation of typical 2.5 mW at a peak wavelength at 375 nm.

Specifications

- Structure: InGaN
- Peak Wavelength: typ. 375 nm
- Optical Output Power: typ. 2.5 mW
- Resin Material: Clear silicone resin
- Solder: Lead free



Absolute Maximum Ratings ($T_a=25^\circ\text{C}$)

Type	Symbol	Value	Unit
Power Dissipation	P_D	200	mW
Forward Current	I_F	50	mA
Reverse Voltage	V_R	5	V
Operating Temperature	T_{OP}	-30 ... +85	$^\circ\text{C}$
Storage Temperature	T_{STG}	-40 ... +100	$^\circ\text{C}$
Soldering Temperature (for 5 sec.)	T_{SOL}	265	$^\circ\text{C}$

Electro-Optical Characteristics ($T_a=25^\circ\text{C}$)

Item	Symbol	Condition	Min.	Typ.	Max.	Unit
Forward Voltage	V_F	$I_F = 20 \text{ mA}$	-	3.8	4.3	V
Reverse Current	I_R	$V_R = 5 \text{ V}$	-	-	10	μA
Radiated Power	P_O	$I_F = 20 \text{ mA}$	-	2.5	-	mW
Peak Wavelength	λ_P	$I_F = 20 \text{ mA}$	370	375	380	nm
Half Width	$\Delta\lambda$	$I_F = 20 \text{ mA}$	-	10	-	nm



Characteristics of Radiant Intensity ($T_a=25^\circ\text{C}$)

Type	Viewing Half Angle	Radiation Intensity ($I_F = 20 \text{ mA}$) [Unit: mW/sr]			Outer Dimension	Dimension Figure
		Min.	Typ.	Max.		
LED375-01	$\pm 8^\circ$		7.0		$\varnothing 5$	1
LED375-02	$\pm 5^\circ$		11.0		$\varnothing 5$	2
LED375-03	$\pm 10^\circ$		7.0		$\varnothing 5$	3
LED375-04	$\pm 20^\circ$		2.5		$\varnothing 5$	4
LED375-05	$\pm 50^\circ$		0.5		$\varnothing 5$	5
LED375-06	$\pm 4^\circ$		13.0		$\varnothing 5$	6
LED375-09	$\pm 25^\circ$ (long)				$\varnothing 5$	7
	$\pm 10^\circ$ (short)				Oval	
LED375-46					$\varnothing 5$	8
LED375-41	$\pm 14^\circ$				$\varnothing 4$	9
LED375-42	$\pm 20^\circ$				$\varnothing 4$	10
LED375-31					$\varnothing 3$	11
LED375-33	$\pm 13^\circ$		4.0		$\varnothing 3$	12
LED375-34					$\varnothing 3$	13
LED375-36	$\pm 25^\circ$		2.0		$\varnothing 3$	14

* Radiant Power is measured by S3584-08

* Radiant Intensity is measured by Ando Optical Multi Meter AQ2140 & AQ2741

The above specifications are for reference purpose only and subjected to change without prior notice.

Outer Dimensions

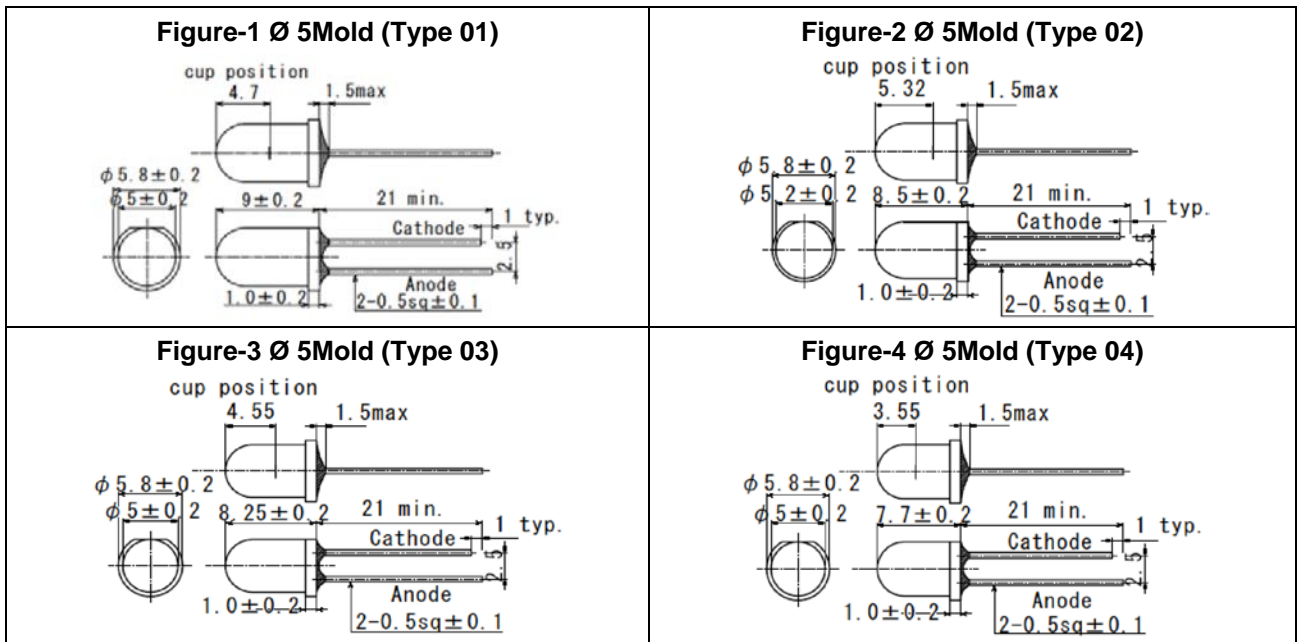



<p>Figure-5 Ø 5Mold (Type 05)</p>	<p>Figure-6 Ø 5Mold (Type 06)</p>
<p>Figure-7 Ø 5Mold (Type 09)</p>	<p>Figure-8 Ø 5Mold (Type 46)</p>
<p>Figure-9 Ø 4Mold (Type 41)</p>	<p>Figure-10 Ø 4Mold (Type 42)</p>
<p>Figure-11 Ø 3Mold (Type 31)</p>	<p>Figure-12 Ø 3Mold (Type 33)</p>
<p>Figure-13 Ø 3Mold (Type 34)</p>	<p>Figure-14 Ø 3Mold (Type 36)</p>



Viewing half angle

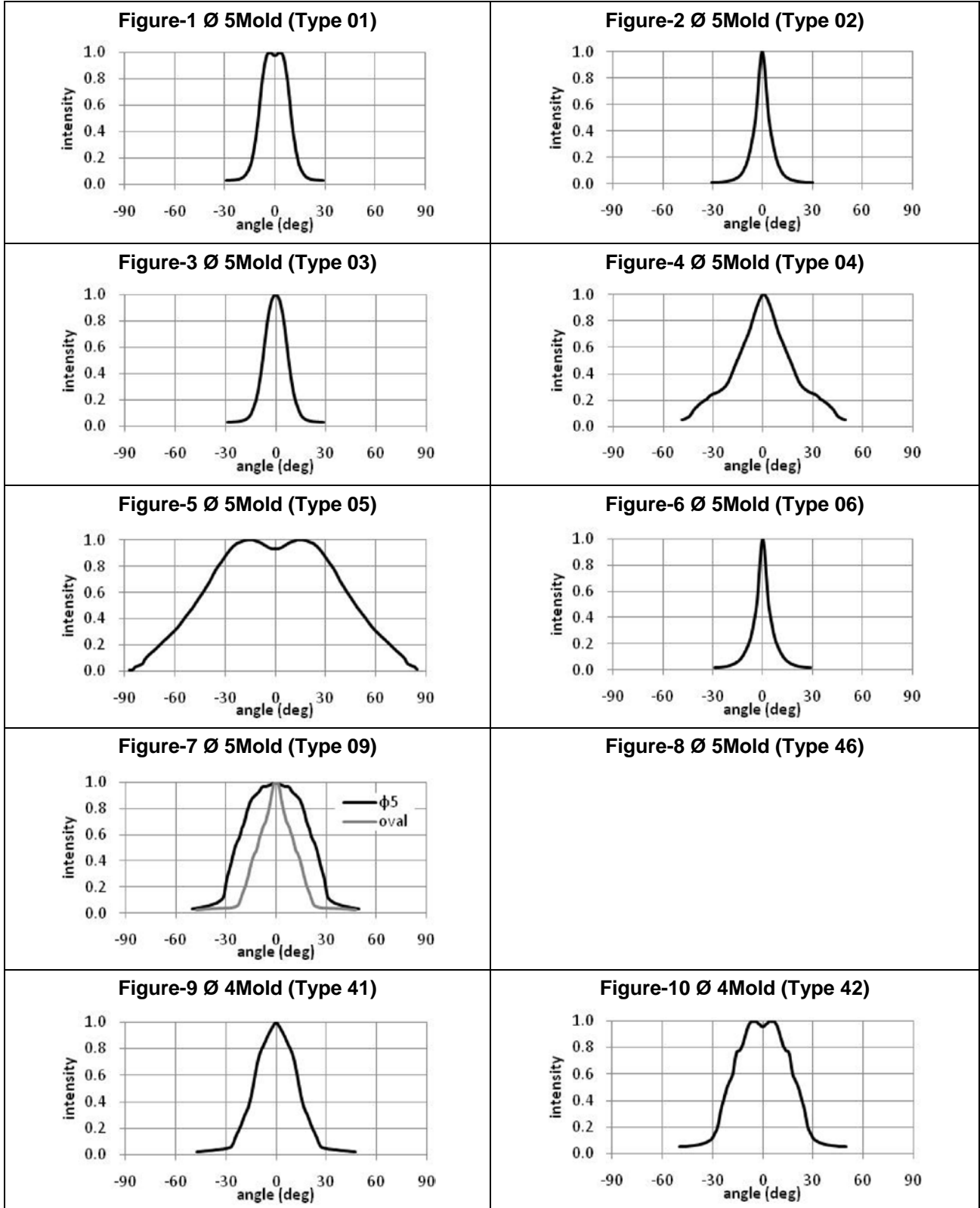



Figure-11 Ø 3Mold (Type 31)

Figure-12 Ø 3Mold (Type 33)

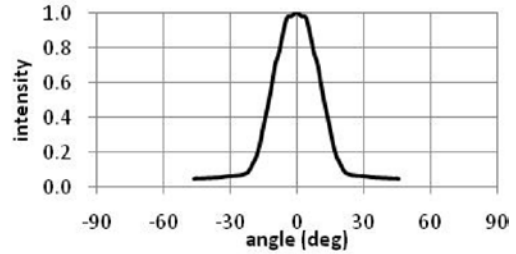
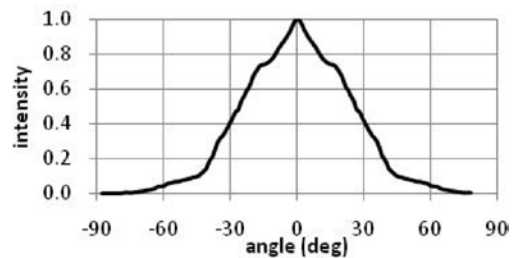

Figure-13 Ø 3Mold (Type 34)

Figure-14 Ø 3Mold (Type 36)



Typical Performance Curves

Forward Current – Forward Voltage

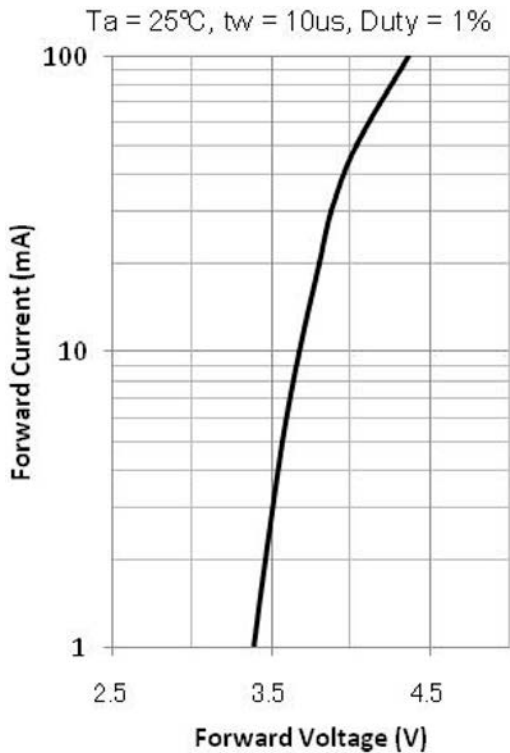

Relative Radiant Intensity – Pulsed Forward Current

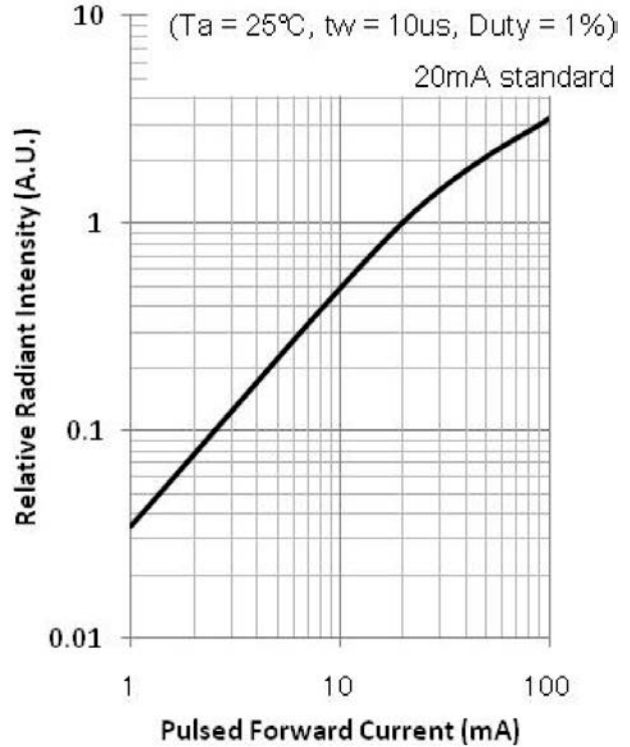



Forward Current – Pulse Duration

Forward Voltage – Ambient Temperature

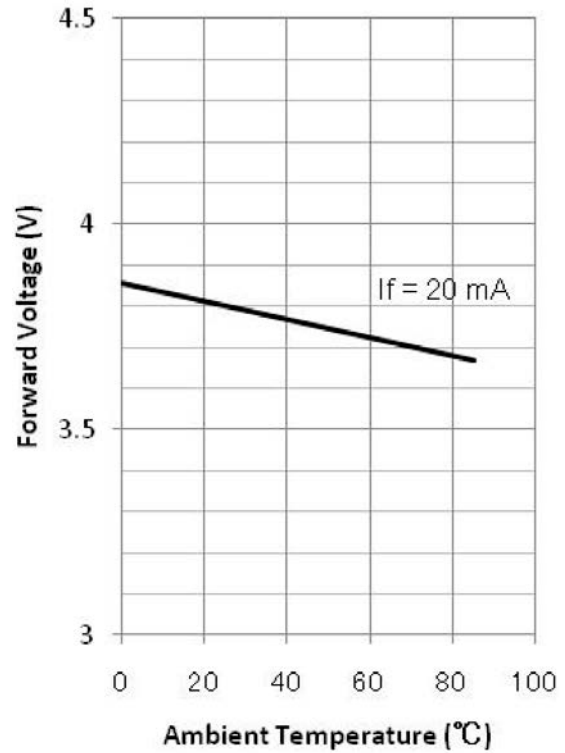

Relative Radiant Intensity – Ambient Temperature

Allowable Forward Current – Ambient Temperature

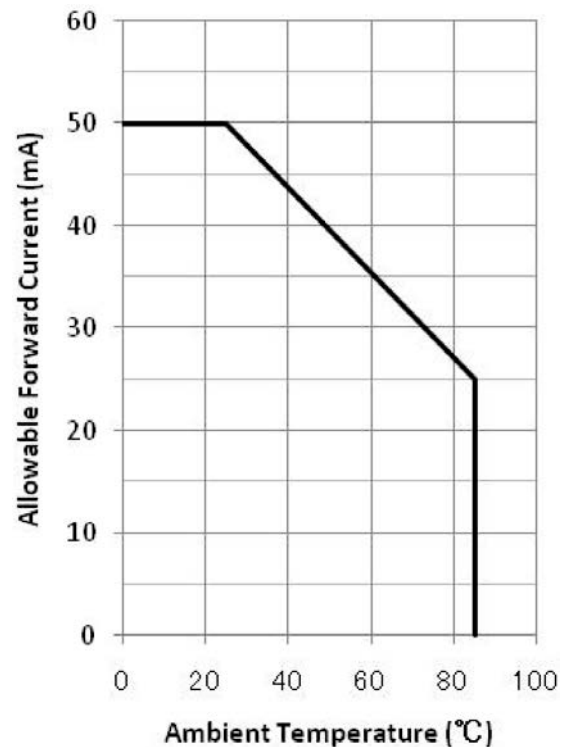
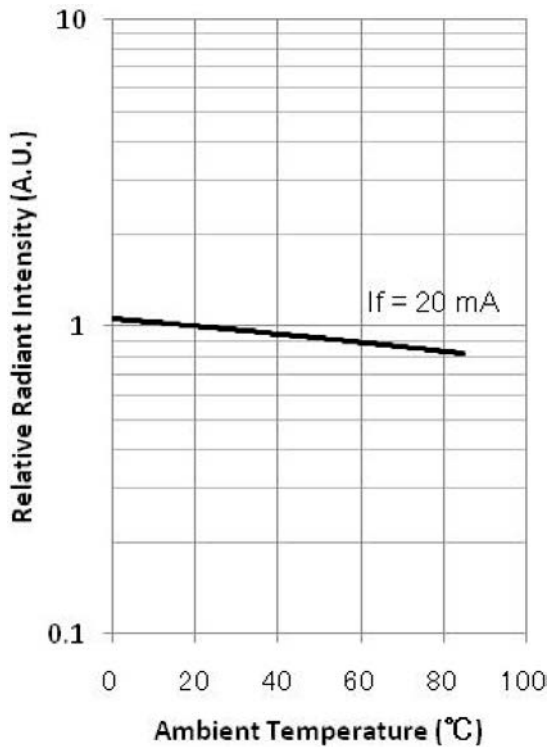

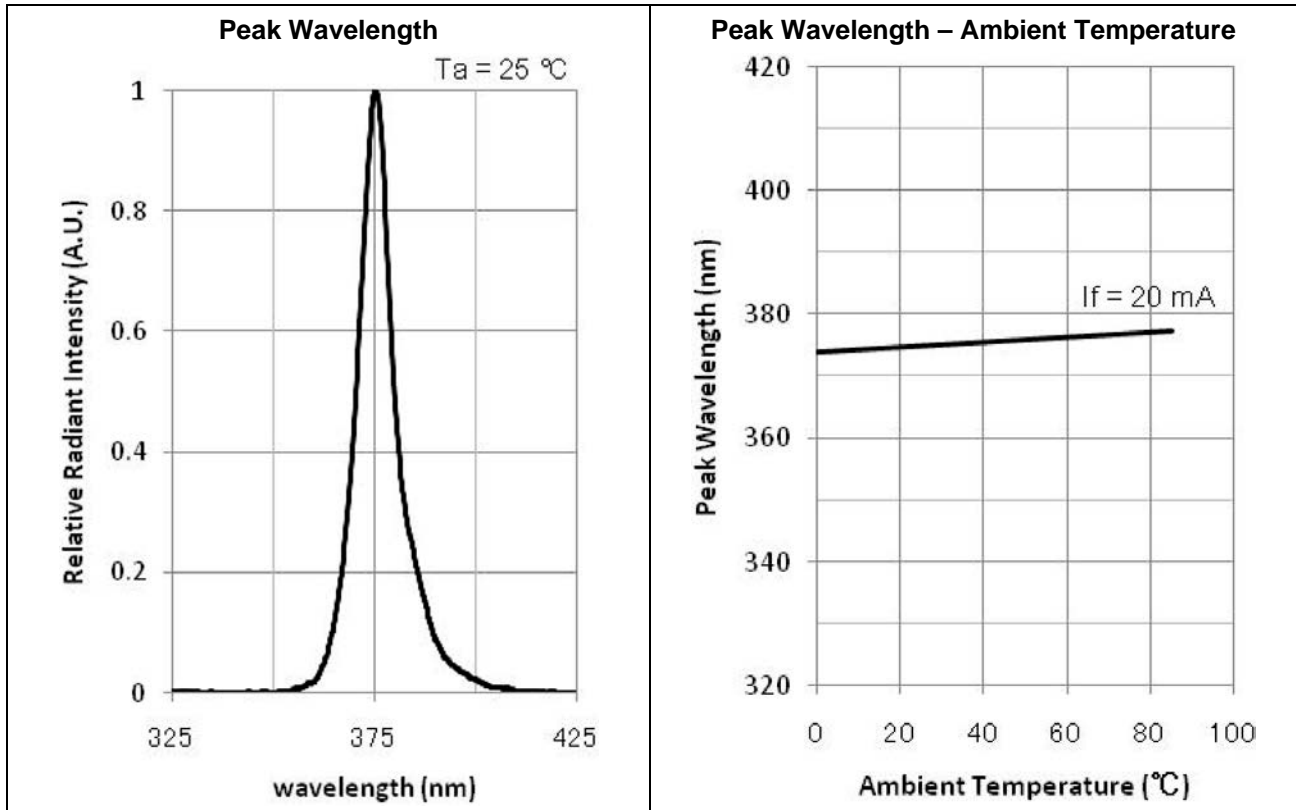

Precaution for Use

1. Cautions

- DO NOT look directly into the emitted light or look through the optical system. To prevent in adequate exposure of the radiation, wear protective glasses.
- The LEDs are emitting UV light.

2. Lead Forming

- When forming leads, the leads should be bent at a point at least 3 mm from the base of the lead. DO NOT use the base of the leadframe as a fulcrum during lead forming.
- Lead forming should be done before soldering.
- DO NOT apply any bending stress to the base of the lead. The stress to the base may damage the LED's characteristics or it may break the LEDs.
- When mounted the LEDs onto the printed circuit board, the holes on the circuit board should be exactly aligned with the leads of LEDs. If the LEDs are mounted with stress at the leads, it causes deterioration of the lead and it will degrade the LEDs.



Recommended Land Layout (Unit: mm)

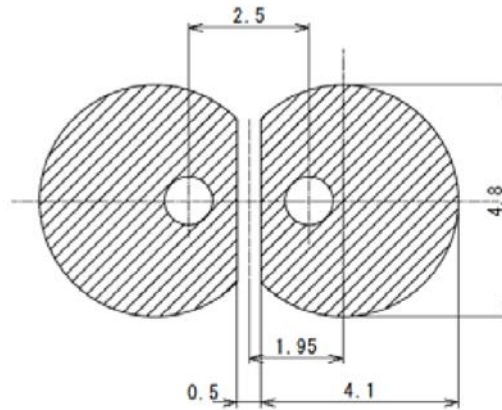

3. Soldering Conditions

- Solder the LEDs no closer than 3 mm from the base of the lead.
- DO NOT apply any stress to the lead particularly when heat.
- The LEDs must not be reposition after soldering.
- After soldering the LEDs, the lead should be protected from mechanical shock or vibration until the LEDs return to room temperature.
- When it is necessary to clamp the LEDs to prevent soldering failure, it is important to minimize the mechanical stress on the LEDs.
- Cut the LED leads at room temperature. Cutting the leads at high temperature may cause the failure of the LEDs.

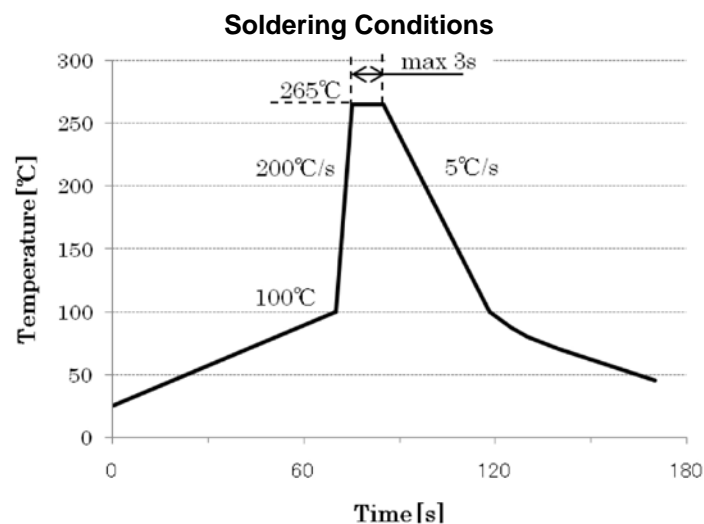

4. Static Electricity

- The LEDs are very sensitive to Static Electricity and surge voltage. So it is recommended that a wrist band or an anti-electrostatic glove be used when handling the LEDs.
- All devices, equipment and machinery must be grounded properly. It is recommended that precautions should be taken against surge voltage to the equipment that mounts the LEDs.