

LM2724A High Speed 3A Synchronous MOSFET Driver

Check for Samples: [LM2724A](#)

FEATURES

- Shoot-Through Protection
- Input Under-Voltage-Lock-Out
- 3A Peak Driving Current
- 195 μ A Quiescent Current
- 28V Input Voltage in Buck Configuration
- SOIC-8 and WSON Packages

APPLICATIONS

- High Current DC/DC Power Supplies
- High Input Voltage Switching Regulators
- Fast Transient Microprocessors
- Notebook Computers

DESCRIPTION

The LM2724A is a dual N-channel MOSFET driver which can drive both the top and bottom MOSFETs in a push-pull structure simultaneously. The LM2724A takes a logic input and splits it into two complimentary signals with a typical 20ns dead time in between. The built-in cross-conduction protection circuitry prevents the top and bottom MOSFETs from turning on simultaneously. With a bias voltage of 5V, the peak sourcing and sinking current for each driver of the LM2724A is about 3A. Input UVLO (Under-Voltage-Lock-Out) ensures that all the driver outputs stay low until the supply rail exceeds the power-on threshold during system power on, or after the supply rail drops below power-on threshold by a specified hysteresis during system power down. The cross-conduction protection circuitry detects both driver outputs and will not turn on a driver until the other driver output is low. The top gate voltage needed by the top MOSFET is obtained through an external boot-strap structure. When not switching, the LM2724A only draws up to 195 μ A from the 5V rail. The synchronization operation of the bottom MOSFET can be disabled by pulling the SYNC pin to ground.

TYPICAL APPLICATION

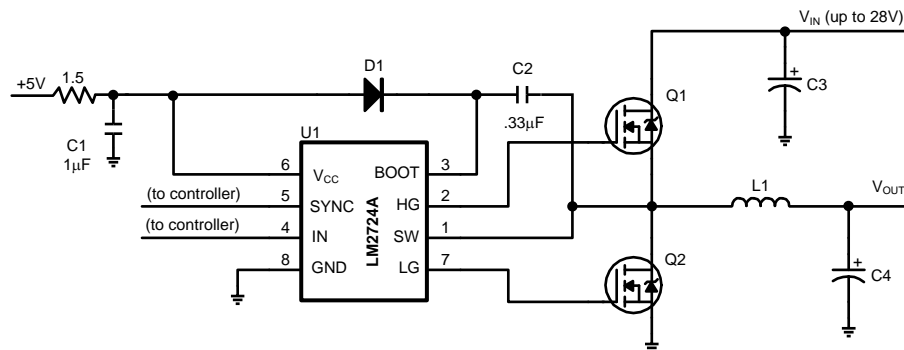

Please be aware that an important notice concerning availability, standard warranty, and use in critical applications of Texas Instruments semiconductor products and disclaimers thereto appears at the end of this data sheet.

All trademarks are the property of their respective owners.



These devices have limited built-in ESD protection. The leads should be shorted together or the device placed in conductive foam during storage or handling to prevent electrostatic damage to the MOS gates.

CONNECTION DIAGRAM

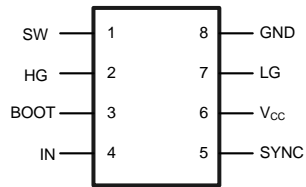

Figure 1. 8-Lead SOIC
See Package Number D

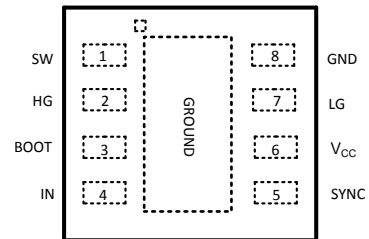
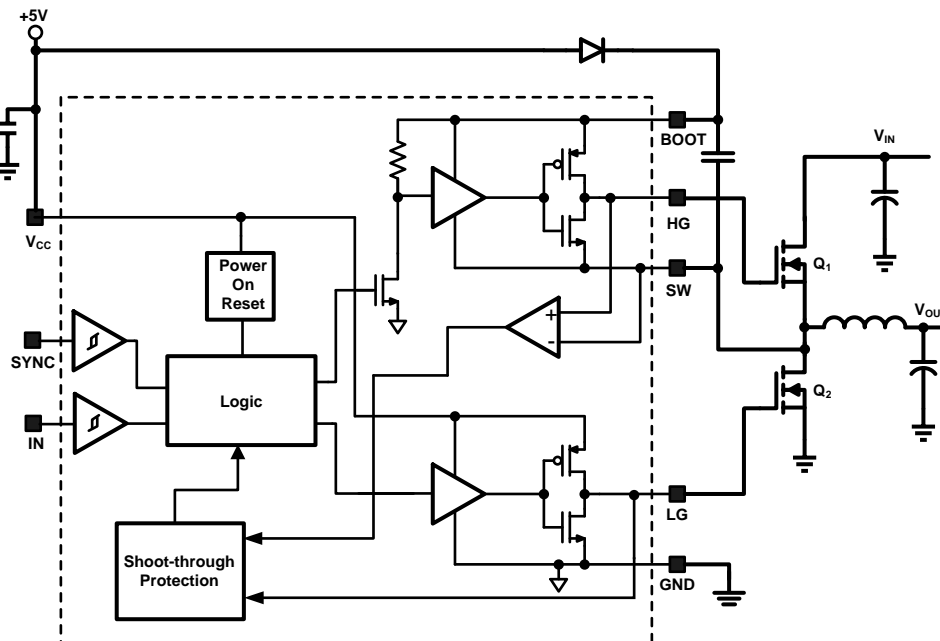

Figure 2. 8-Lead WSON
See Package Number NGN

PIN DESCRIPTIONS

Pin	Name	Function
1	SW	Top driver return. Should be connected to the common node of top and bottom FETs
2	HG	Top gate drive output. Should be connected to the top FET gate.
3	BOOT	Bootstrap. Accepts a bootstrap voltage for powering the high-side driver
4	IN	Accepts a logic control signal
5	SYNC	Bottom gate enable
6	V _{CC}	Connect to +5V supply
7	LG	Bottom gate drive output. Should be connected to the bottom FET gate.
8	GND	Ground

BLOCK DIAGRAM



ABSOLUTE MAXIMUM RATINGS⁽¹⁾⁽²⁾

		VALUE / UNITS
V _{CC}		7V
BOOT to SW		7V
BOOT to GND ⁽³⁾		35V
SW to GND ⁽⁴⁾		-2V to 30V
Junction Temperature		+150°C
Power Dissipation ⁽⁵⁾		720mW (SOIC-8) 3.2W (WSON-8)
Storage Temperature		-65°C to 150°C
ESD Susceptibility	Human Body Model ⁽⁶⁾	2.0 kV
Soldering Time, Temperature		10sec., 300°C

- (1) **Absolute Maximum Ratings** are limits beyond which damage to the device may occur. **Operating ratings** are conditions under which the device operates correctly. The ensured specifications apply only for the listed test conditions. Some performance characteristics may degrade when the part is not operated under listed conditions.
- (2) If Military/Aerospace specified devices are required, please contact the Texas Instruments Sales Office/Distributors for availability and specifications.
- (3) If BOOT voltage exceeds this value, the ESD structure will degrade.
- (4) The SW pin can have -2V to -0.5V applied for a maximum duty cycle of 10% with a maximum period of 1 second. There is no duty cycle or maximum period limitation for a SW pin voltage range of -0.5V to 30V.
- (5) Maximum allowable power dissipation is a function of the maximum junction temperature, T_{JMAX}, the junction-to-ambient thermal resistance, θ_{JA}, and the ambient temperature, T_A. The maximum allowable power dissipation at any ambient temperature is calculated using: P_{MAX} = (T_{JMAX} - T_A) / θ_{JA}. The junction-to-ambient thermal resistance, θ_{JA}, for LM2724A is 172°C/W. For a T_{JMAX} of 150°C and T_A of 25°C, the maximum allowable power dissipation is 0.7W. The θ_{JA}, for LM2724A WSON package is 39°C/W. For a T_{JMAX} of 150°C and T_A of 25°C, the maximum allowable power dissipation is 3.2W.
- (6) ESD machine model susceptibility is 200V.

RECOMMENDED OPERATING CONDITIONS⁽¹⁾

		VALUE / UNITS
V _{CC}		4.3V to 6.8V
Junction Temperature Range		-40°C to 125°C

- (1) **Absolute Maximum Ratings** are limits beyond which damage to the device may occur. **Operating ratings** are conditions under which the device operates correctly. The ensured specifications apply only for the listed test conditions. Some performance characteristics may degrade when the part is not operated under listed conditions.

Electrical Characteristics — LM2724A

$V_{CC} = \text{BOOT} = \text{SYNC} = 5\text{V}$, $\text{SW} = \text{GND} = 0\text{V}$, unless otherwise specified. Typicals and limits appearing in plain type apply for $T_A = T_J = +25^\circ\text{C}$. Limits appearing in **boldface** type apply over the entire operating temperature range.

Symbol	Parameter	Condition	Min	Typ	Max	Units
POWER SUPPLY						
I_{q_op}	Operating Quiescent Current	IN = 0V		145	195	μA
TOP DRIVER						
	Peak Pull-Up Current			3.0		A
	Pull-Up Rds_on	$I_{\text{BOOT}} = I_{\text{HG}} = 0.3\text{A}$		1.2		Ω
	Peak Pull-down Current			-3.2		A
	Pull-down Rds_on	$I_{\text{SW}} = I_{\text{HG}} = 0.3\text{A}$		0.5		Ω
t_4	Rise Time	Timing Diagram, $C_{\text{LOAD}} = 3.3\text{nF}$		17		ns
t_6	Fall Time			12		ns
t_3	Pull-Up Dead Time	Timing Diagram		19		ns
t_5	Pull-Down Delay	Timing Diagram, from IN Falling Edge		27		ns
BOTTOM DRIVER						
	Peak Pull-Up Current			3.2		A
	Pull-up Rds_on	$I_{VCC} = I_{LG} = 0.3\text{A}$		1.1		Ω
	Peak Pull-down Current			3.2		A
	Pull-down Rds_on	$I_{\text{GND}} = I_{LG} = 0.3\text{A}$		0.6		Ω
t_8	Rise Time	Timing Diagram, $C_{\text{LOAD}} = 3.3\text{nF}$		17		ns
t_2	Fall Time			14		ns
t_7	Pull-up Dead Time	Timing Diagram		22		ns
t_1	Pull-down Delay	Timing Diagram		13		ns
LOGIC						
$V_{\text{uvlo_up}}$	V_{CC} Under-Voltage-Lock-Out Upper Threshold	V_{CC} rises from 0V toward 5V			4	V
$V_{\text{uvlo_dn}}$	V_{CC} Under-Voltage-Lock-Out Lower Threshold	V_{CC} falls from 5V toward 0V	2.5			V
$V_{\text{uvlo_hys}}$	V_{CC} Under-Voltage-Lock-Out Hysteresis	V_{CC} falls from 5V toward 0V		0.8		V
$V_{\text{IH_SYNC}}$	SYNC Pin High Input		55%			V_{CC}
$V_{\text{IL_SYNC}}$	SYNC Pin Low Input				25%	
$I_{\text{leak_SYNC}}$	SYNC Pin Leakage Current	SYNC = 5V, Sink Current			2	μA
		SYNC = 0V, Source Current			10	
$I_{\text{leak_IN}}$	IN Pin Leakage Current	IN = 0V, Source Current			2	μA
		IN = 5V, Sink Current			10	
$t_{\text{on_min1}}$	Minimum Positive Pulse Width at IN Pin ⁽¹⁾			160		ns
$t_{\text{on_min2}}$	Minimum Positive Pulse Width at IN Pin for HG to Respond ⁽²⁾			45		
$t_{\text{on_min3}}$	Minimum Positive Pulse Width at IN Pin for LG to Respond ⁽³⁾			10		
$t_{\text{off_min1}}$	Minimum Negative Pulse Width at IN Pin for LG to Respond ⁽⁴⁾			40		
$t_{\text{off_min2}}$	Minimum Negative Pulse Width at IN Pin for HG to Respond ⁽⁵⁾			5		
$V_{\text{IH_IN}}$	IN High Level Input Voltage	When IN pin goes high from 0V	55%			V_{CC}
$V_{\text{IL_IN}}$	IN Low Level Input Voltage	When IN pin goes low from 5V			25%	

- (1) If the positive pulse width at IN pin is below this value but above $t_{\text{on_min2}}$, the pulse is internally stretched to $t_{\text{on_min1}}$, so the HG width will be a constant value.
- (2) If the positive pulse width at IN pin is below this value but above $t_{\text{on_min3}}$, then HG stops responding while LG still responds to the pulse.
- (3) If the positive pulse width at IN pin is below this value, the pulse will be completely ignored. Neither HG or LG will respond to it.
- (4) If the negative pulse width at IN pin is below this value but above $t_{\text{off_min2}}$, then LG stops responding while HG still responds.
- (5) If the negative pulse width at IN pin is below this value, the pulse will be completely ignored. Neither HG or LG will respond to it.

TIMING DIAGRAM

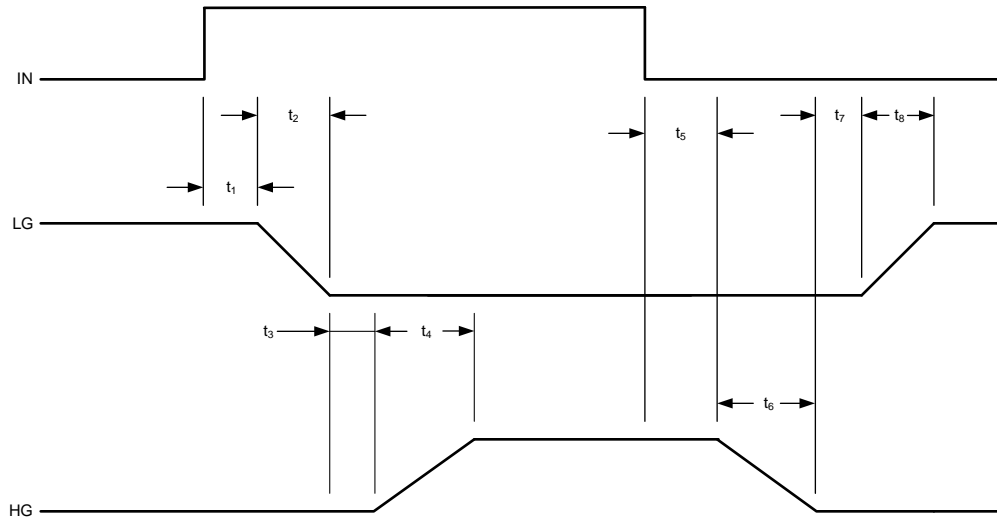

REVISION HISTORY

Changes from Revision B (March 2013) to Revision C

Page

-
- Changed layout of National Data Sheet to TI format [5](#)
-

PACKAGING INFORMATION

Orderable Device	Status (1)	Package Type	Package Drawing	Pins	Package Qty	Eco Plan (2)	Lead/Ball Finish	MSL Peak Temp (3)	Op Temp (°C)	Top-Side Markings (4)	Samples
LM2724AMX	NRND	SOIC	D	8	2500	TBD	Call TI	Call TI		2724 AM	
LM2724AMX/NOPB	NRND	SOIC	D	8	2500	Green (RoHS & no Sb/Br)	CU SN	Level-1-260C-UNLIM		2724 AM	

(1) The marketing status values are defined as follows:

ACTIVE: Product device recommended for new designs.

LIFEBUY: TI has announced that the device will be discontinued, and a lifetime-buy period is in effect.

NRND: Not recommended for new designs. Device is in production to support existing customers, but TI does not recommend using this part in a new design.

PREVIEW: Device has been announced but is not in production. Samples may or may not be available.

OBSOLETE: TI has discontinued the production of the device.

(2) Eco Plan - The planned eco-friendly classification: Pb-Free (RoHS), Pb-Free (RoHS Exempt), or Green (RoHS & no Sb/Br) - please check <http://www.ti.com/productcontent> for the latest availability information and additional product content details.

TBD: The Pb-Free/Green conversion plan has not been defined.

Pb-Free (RoHS): TI's terms "Lead-Free" or "Pb-Free" mean semiconductor products that are compatible with the current RoHS requirements for all 6 substances, including the requirement that lead not exceed 0.1% by weight in homogeneous materials. Where designed to be soldered at high temperatures, TI Pb-Free products are suitable for use in specified lead-free processes.

Pb-Free (RoHS Exempt): This component has a RoHS exemption for either 1) lead-based flip-chip solder bumps used between the die and package, or 2) lead-based die adhesive used between the die and leadframe. The component is otherwise considered Pb-Free (RoHS compatible) as defined above.

Green (RoHS & no Sb/Br): TI defines "Green" to mean Pb-Free (RoHS compatible), and free of Bromine (Br) and Antimony (Sb) based flame retardants (Br or Sb do not exceed 0.1% by weight in homogeneous material)

(3) MSL, Peak Temp. -- The Moisture Sensitivity Level rating according to the JEDEC industry standard classifications, and peak solder temperature.

(4) Multiple Top-Side Markings will be inside parentheses. Only one Top-Side Marking contained in parentheses and separated by a "~" will appear on a device. If a line is indented then it is a continuation of the previous line and the two combined represent the entire Top-Side Marking for that device.

Important Information and Disclaimer: The information provided on this page represents TI's knowledge and belief as of the date that it is provided. TI bases its knowledge and belief on information provided by third parties, and makes no representation or warranty as to the accuracy of such information. Efforts are underway to better integrate information from third parties. TI has taken and continues to take reasonable steps to provide representative and accurate information but may not have conducted destructive testing or chemical analysis on incoming materials and chemicals. TI and TI suppliers consider certain information to be proprietary, and thus CAS numbers and other limited information may not be available for release.

In no event shall TI's liability arising out of such information exceed the total purchase price of the TI part(s) at issue in this document sold by TI to Customer on an annual basis.

TAPE AND REEL INFORMATION



QUADRANT ASSIGNMENTS FOR PIN 1 ORIENTATION IN TAPE



*All dimensions are nominal

Device	Package Type	Package Drawing	Pins	SPQ	Reel Diameter (mm)	Reel Width W1 (mm)	A0 (mm)	B0 (mm)	K0 (mm)	P1 (mm)	W (mm)	Pin1 Quadrant
LM2724AMX	SOIC	D	8	2500	330.0	12.4	6.5	5.4	2.0	8.0	12.0	Q1
LM2724AMX/NOPB	SOIC	D	8	2500	330.0	12.4	6.5	5.4	2.0	8.0	12.0	Q1

TAPE AND REEL BOX DIMENSIONS

*All dimensions are nominal

Device	Package Type	Package Drawing	Pins	SPQ	Length (mm)	Width (mm)	Height (mm)
LM2724AMX	SOIC	D	8	2500	367.0	367.0	35.0
LM2724AMX/NOPB	SOIC	D	8	2500	367.0	367.0	35.0

IMPORTANT NOTICE

Texas Instruments Incorporated and its subsidiaries (TI) reserve the right to make corrections, enhancements, improvements and other changes to its semiconductor products and services per JESD46, latest issue, and to discontinue any product or service per JESD48, latest issue. Buyers should obtain the latest relevant information before placing orders and should verify that such information is current and complete. All semiconductor products (also referred to herein as "components") are sold subject to TI's terms and conditions of sale supplied at the time of order acknowledgment.

TI warrants performance of its components to the specifications applicable at the time of sale, in accordance with the warranty in TI's terms and conditions of sale of semiconductor products. Testing and other quality control techniques are used to the extent TI deems necessary to support this warranty. Except where mandated by applicable law, testing of all parameters of each component is not necessarily performed.

TI assumes no liability for applications assistance or the design of Buyers' products. Buyers are responsible for their products and applications using TI components. To minimize the risks associated with Buyers' products and applications, Buyers should provide adequate design and operating safeguards.

TI does not warrant or represent that any license, either express or implied, is granted under any patent right, copyright, mask work right, or other intellectual property right relating to any combination, machine, or process in which TI components or services are used. Information published by TI regarding third-party products or services does not constitute a license to use such products or services or a warranty or endorsement thereof. Use of such information may require a license from a third party under the patents or other intellectual property of the third party, or a license from TI under the patents or other intellectual property of TI.

Reproduction of significant portions of TI information in TI data books or data sheets is permissible only if reproduction is without alteration and is accompanied by all associated warranties, conditions, limitations, and notices. TI is not responsible or liable for such altered documentation. Information of third parties may be subject to additional restrictions.

Resale of TI components or services with statements different from or beyond the parameters stated by TI for that component or service voids all express and any implied warranties for the associated TI component or service and is an unfair and deceptive business practice. TI is not responsible or liable for any such statements.

Buyer acknowledges and agrees that it is solely responsible for compliance with all legal, regulatory and safety-related requirements concerning its products, and any use of TI components in its applications, notwithstanding any applications-related information or support that may be provided by TI. Buyer represents and agrees that it has all the necessary expertise to create and implement safeguards which anticipate dangerous consequences of failures, monitor failures and their consequences, lessen the likelihood of failures that might cause harm and take appropriate remedial actions. Buyer will fully indemnify TI and its representatives against any damages arising out of the use of any TI components in safety-critical applications.

In some cases, TI components may be promoted specifically to facilitate safety-related applications. With such components, TI's goal is to help enable customers to design and create their own end-product solutions that meet applicable functional safety standards and requirements. Nonetheless, such components are subject to these terms.

No TI components are authorized for use in FDA Class III (or similar life-critical medical equipment) unless authorized officers of the parties have executed a special agreement specifically governing such use.

Only those TI components which TI has specifically designated as military grade or "enhanced plastic" are designed and intended for use in military/aerospace applications or environments. Buyer acknowledges and agrees that any military or aerospace use of TI components which have **not** been so designated is solely at the Buyer's risk, and that Buyer is solely responsible for compliance with all legal and regulatory requirements in connection with such use.

TI has specifically designated certain components as meeting ISO/TS16949 requirements, mainly for automotive use. In any case of use of non-designated products, TI will not be responsible for any failure to meet ISO/TS16949.

Products

Audio	www.ti.com/audio
Amplifiers	amplifier.ti.com
Data Converters	dataconverter.ti.com
DLP® Products	www.dlp.com
DSP	dsp.ti.com
Clocks and Timers	www.ti.com/clocks
Interface	interface.ti.com
Logic	logic.ti.com
Power Mgmt	power.ti.com
Microcontrollers	microcontroller.ti.com
RFID	www.ti-rfid.com
OMAP Applications Processors	www.ti.com/omap
Wireless Connectivity	www.ti.com/wirelessconnectivity

Applications

Automotive and Transportation	www.ti.com/automotive
Communications and Telecom	www.ti.com/communications
Computers and Peripherals	www.ti.com/computers
Consumer Electronics	www.ti.com/consumer-apps
Energy and Lighting	www.ti.com/energy
Industrial	www.ti.com/industrial
Medical	www.ti.com/medical
Security	www.ti.com/security
Space, Avionics and Defense	www.ti.com/space-avionics-defense
Video and Imaging	www.ti.com/video

TI E2E Community

e2e.ti.com