

AS85049/30 TAG® Ring Backshells



TAG® Ring
Backshells

Glenair Connector
Designator F

MIL-DTL-38999 Series I &
II, 40M38277, PAN 6433-1,
PATT 614, PATT 616,
NFC93422 Series HE308 &
HE309

M85049/30-10 W

Basic Part No.

Shell Size

Finish

N = Electroless Nickel

W = 1,000 Hour Cadmium Olive Drab
Over Electroless Nickel

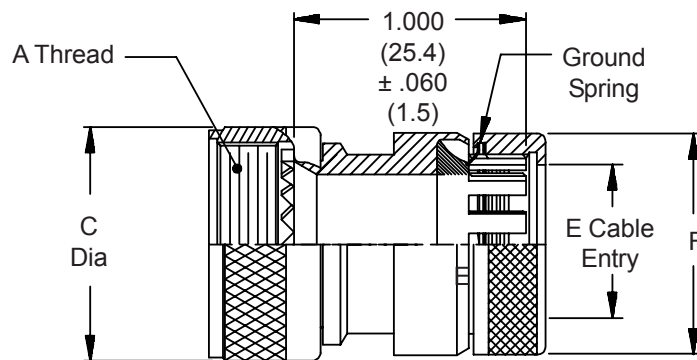

TABLE I

Shell Size	Shell Size		A Thread Class 2B	C Dia Max	E Cable Entry Max	F Dia Max
	Series I Ref.					
08	9	.438 - 28 UNEF	.75 (19.1)	.250 (6.4)	.545 (13.8)	
10	11	.562 - 24 UNEF	.85 (21.6)	.375 (9.5)	.670 (17.0)	
12	13	.688 - 24 UNEF	1.00 (25.4)	.500 (12.7)	.795 (20.2)	
14	15	.813 - 20 UNEF	1.10 (27.9)	.625 (15.9)	.920 (23.4)	
16	17	.938 - 20 UNEF	1.25 (31.8)	.750 (19.1)	1.045 (26.5)	
18	19	1.063 - 18 UNEF	1.40 (35.6)	.844 (21.4)	1.170 (29.7)	
20	21	1.188 - 18 UNEF	1.50 (38.1)	.970 (24.6)	1.295 (32.9)	
22	23	1.313 - 18 UNEF	1.65 (41.9)	1.094 (27.8)	1.420 (36.1)	
24	25	1.438 - 18 UNEF	1.75 (44.5)	1.219 (31.0)	1.670 (42.4)	

1. For complete dimensions see applicable Military Specification.
2. Metric dimensions (mm) are indicated in parentheses.