

LOC		DIST		REVISIONS			
A	66	P	LTM	DESCRIPTION	DATE	OWN	APVD
		-	-	SEE SHEET 1	-	-	-

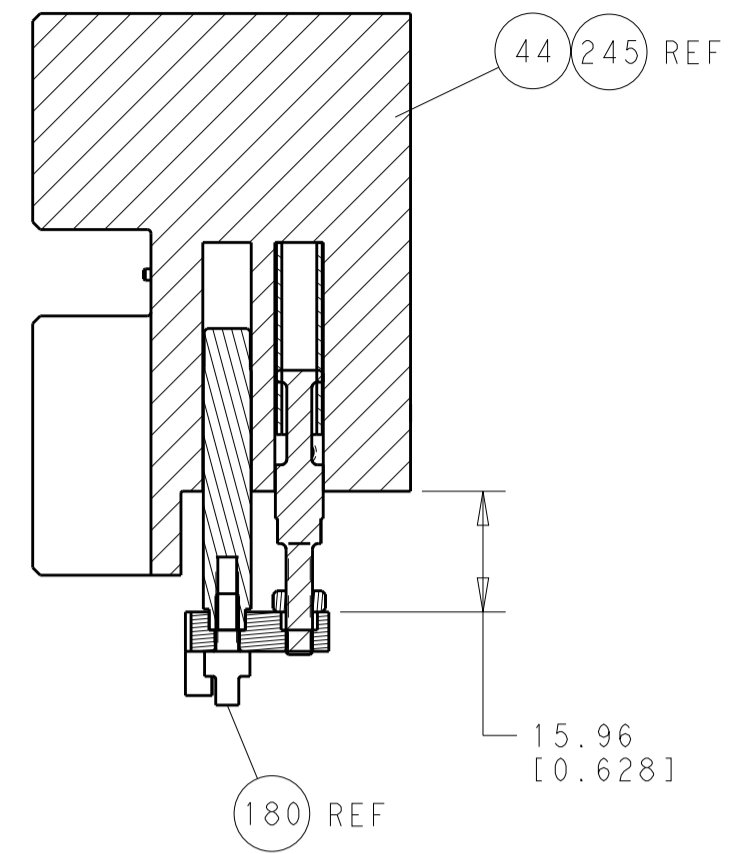

HOLDDOWN SET-UP

FEED TYPE
MECHANICAL

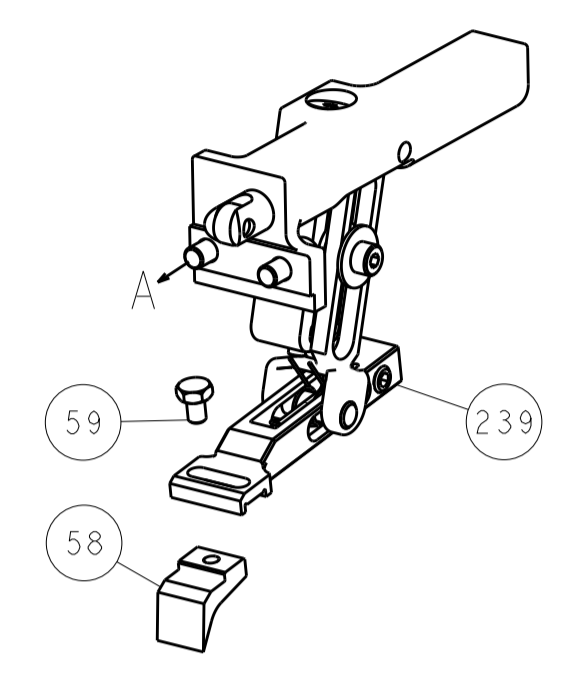

PNEUMATIC

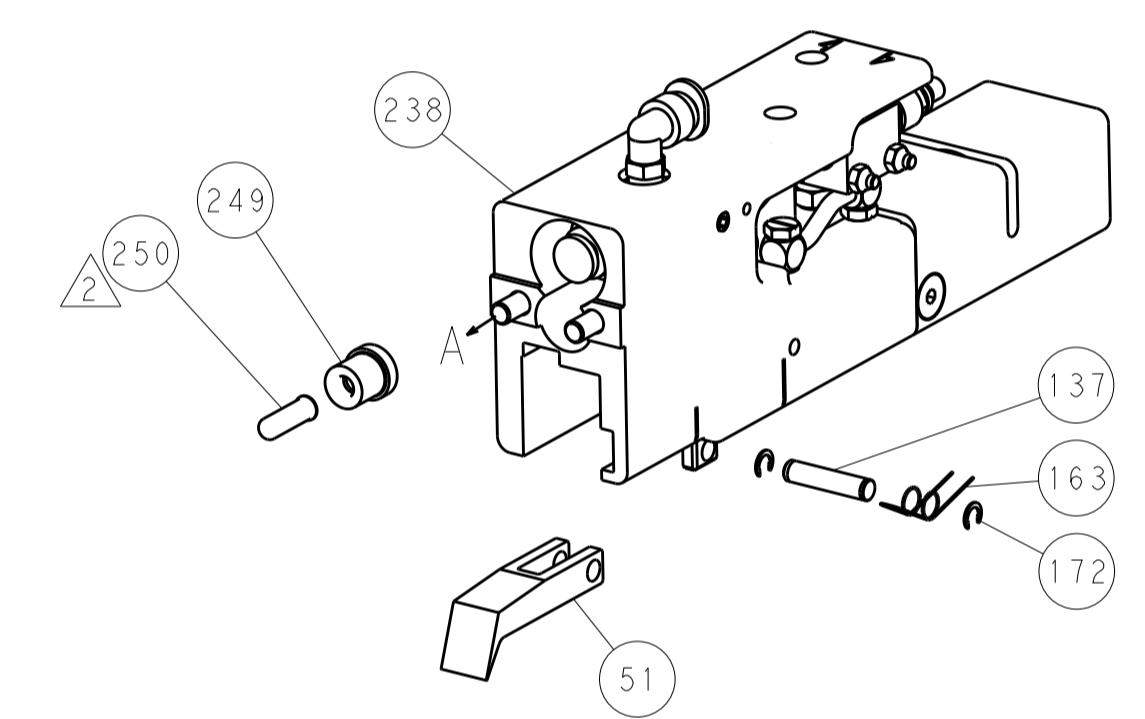

SERVO
LATCH PLATE

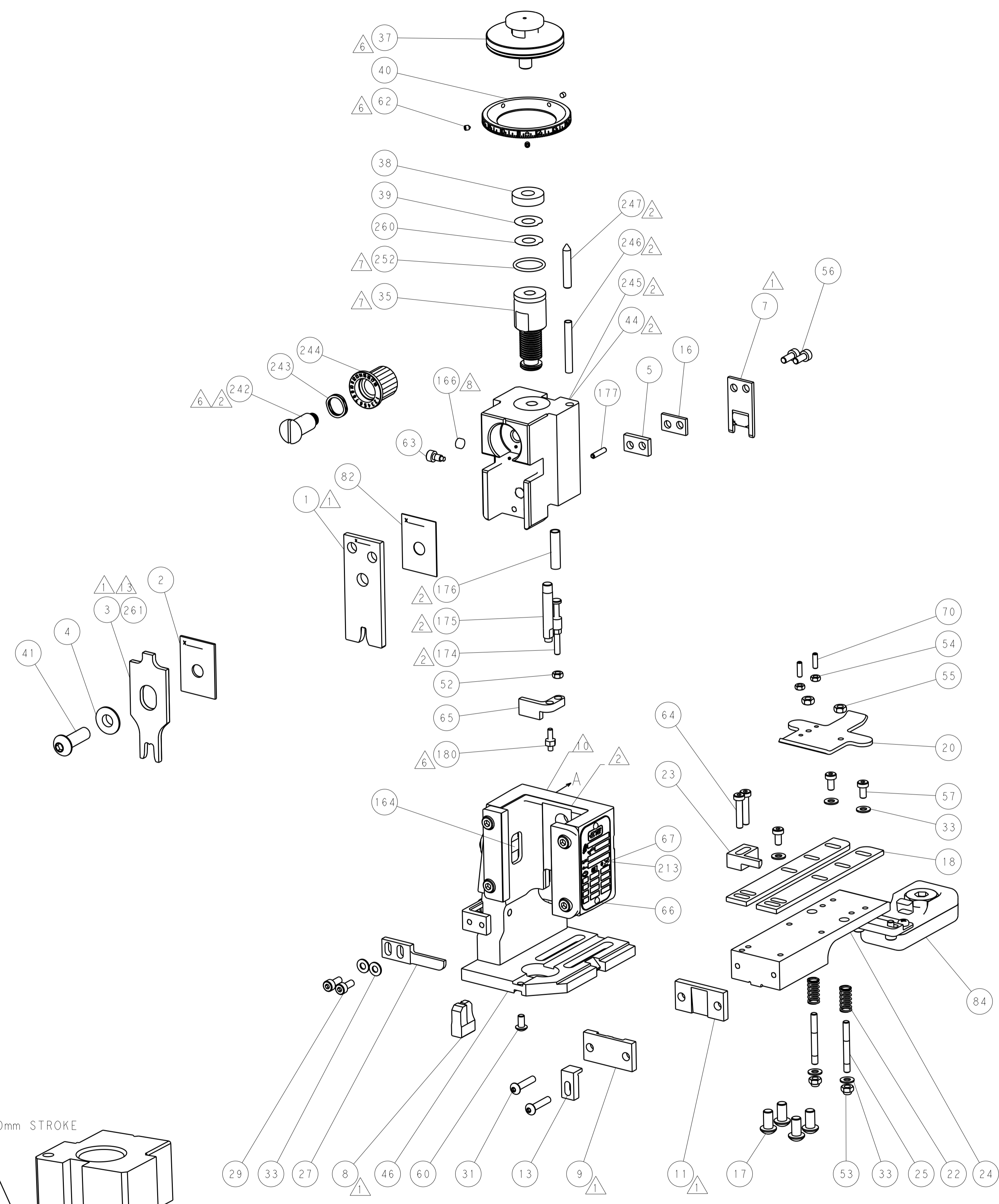
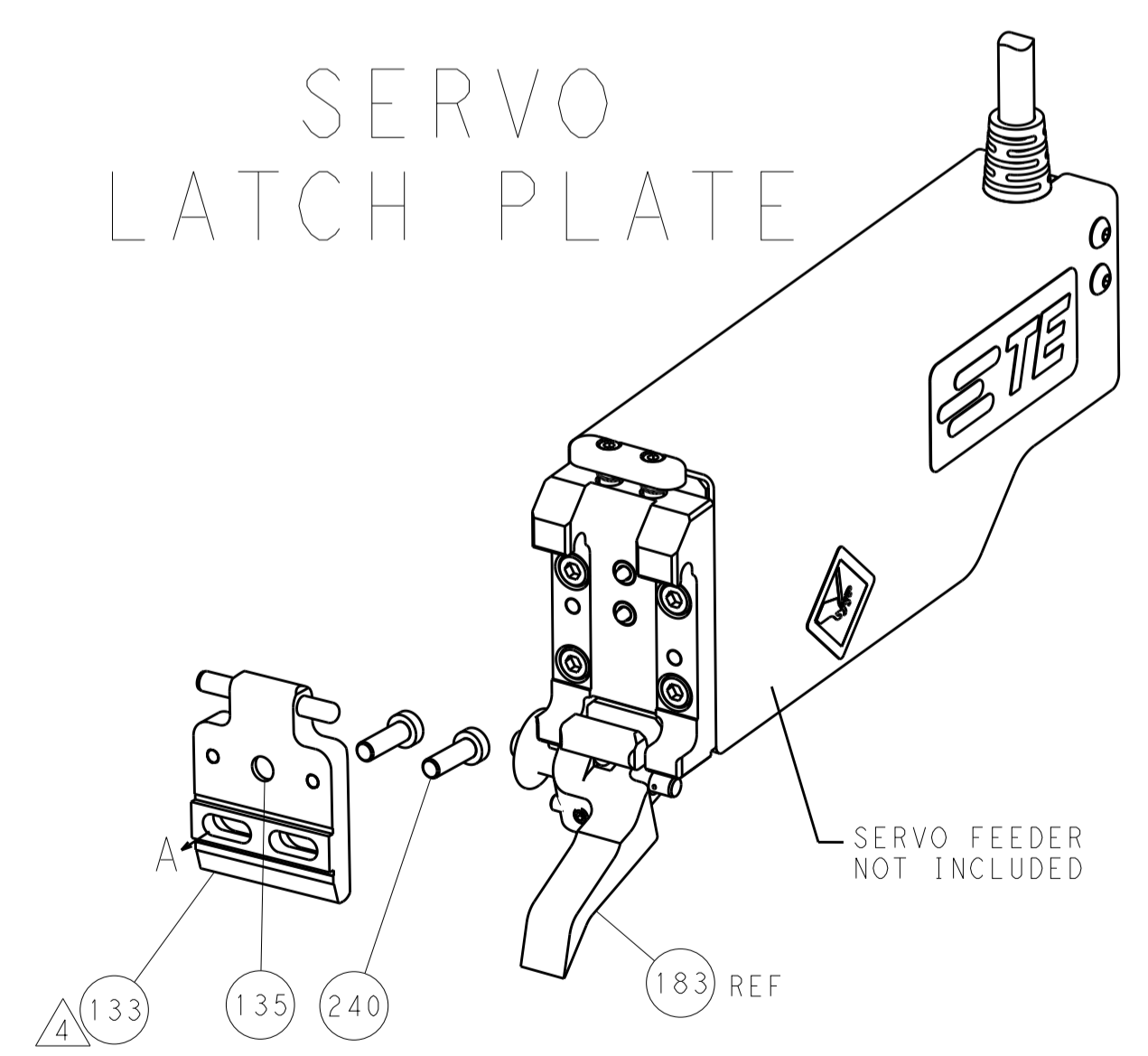

CAM POSITIONS



ATLANTIC VERSION
 Shown on sheets 1 of 4 & 2 of 4
 (Pacific version shown on sheets 3 of 4 & 4 of 4)

DIMENSIONS:		TOLERANCES UNLESS OTHERWISE SPECIFIED:		DWG: X.ZHAO 14MAR2014		TE Connectivity	
mm		0 PLC ±0.5		CHK: L.ZHANG 14MAR2014		Harrisburg, PA 17105-3608	
Ø		1 PLC ±0.13		APP'D: T.FLRIN 14MAR2014		NAME: Ocean End Feed Applicator	
H		2 PLC ±0.013		PRODUCT SPEC		SIZE: CAGE CODE: DRAWING NO: RESTRICTED TO	
L		3 PLC ±0.013		APPLICATION SPEC		A11 00779 ©=2150425	
R		4 PLC ±0.001		WEIGHT		SCALE: 1:1 SHEET 2 OF 4 REV B	
ANGLES		±0.001		MATERIAL		Customer Accessible Production Drawing	
FINISH		-		-		-	

PACIFIC VERSION TERMINATOR INTERFACE ADAPTER	PART NUMBER	REVISION	DESCRIPTION	FEED TYPE	APPLICATOR STYLE CONVERSION CHART						
					CONVERT TO	PART NUMBERS REQUIRED					
	2-2150425-1	B	FINE CRIMP HEIGHT ADJUST	MECHANICAL	PNEUMATIC FEED	2119950-1	2119792-1	-	2119641-2	-	2063440-1
					SERVO LATCH PLATE	2119951-1	1901697-1	8-2150425-5	-	2168400-7 (QUANTITY 2)	
					SMART APPLICATOR	2161326-1	-	8-2150425-4	-	-	
	2-2150425-2	B	FINE CRIMP HEIGHT ADJUST	PNEUMATIC	MECHANICAL FEED	2119949-1	2063961-1	5-18022-5	2119653-2	-	-
					SERVO LATCH PLATE	2119951-1	1901697-1	8-2150425-5	-	2168400-7 (QUANTITY 2)	
					SMART APPLICATOR	2161326-1	-	8-2150425-4	-	-	
	2-2150425-5	B	FINE CRIMP HEIGHT ADJUST	SERVO LATCH PLATE	MECHANICAL FEED	2119949-1	2063961-1	5-18022-5	2119653-2	-	-
					PNEUMATIC FEED	2119950-1	2119792-1	-	2119641-2	-	2063440-1
	2-2150425-7	B	FINE CRIMP HEIGHT ADJUST	NONE	-	-	-	-	-	-	-
	7-2150425-7	A	CRIMP TOOLING KIT	-	-	-	-	-	-	-	-

APPLICATOR DATA		
CRIMP	SIZE	TYPE
WIRE	3.56 mm [1.40]	F
INSUL	7.11 mm [2.80]	F
APPL INSTRUCTIONS 408-10390		

TERMINAL DATA: TE TERMINAL		TE CRIMP SPECIFICATION
TERMINAL NAME: RECEPTACLE, FASTON, LOW-INSERTION, .250 SERIES		
WIRE STRIP LENGTH		INSULATION DIAMETER RANGE
6.02-6.78 mm [1.237-.267 IN]		∅5.33-6.73 mm [1.210-.265 IN]
TERMINAL APPLICATION SPECIFICATION	(A)114-2036	-
	(B)114-35000	-
TERMINALS APPLIED		
TE TERMINAL	TE TERMINAL	TE TERMINAL
(A) 63757-1	(A) 63757-2	(B) 63800-1

WIRE SIZE	CRIMP HEIGHT mm [INCH]	CRIMP HEIGHT REFERENCE SETTING
12 AWG	2.13 +/- 0.050 [0.84 +/- .002]	6.3
14 AWG	1.83 +/- 0.050 [0.72 +/- .002]	9.7
(2) 18	1.75 +/- 0.050 [0.69 +/- .002]	10.3
16 AWG	1.68 +/- 0.05 [0.66 +/- .002]	11.2

- RECOMMENDED SPARE PARTS
- GREASE BEARING SURFACES LIGHTLY
- 3. LUBRICATE DAILY PER THE APPLICATOR INSTRUCTION SHEET SUPPLIED WITH THE APPLICATOR.
- APPLICATOR SPECIFIC DATA TO BE ENTERED INTO BLANK MEMORY CHIP AT ASSEMBLY. SEE BELOW FOR PART NUMBER:
 MECHANICAL FEED WITH "SMART APPLICATOR" CONVERSION: 8-2150425-4
 PNEUMATIC FEED WITH "SMART APPLICATOR" CONVERSION: 8-2150425-4
 SERVO FEED WITH "FINE CRIMP HEIGHT ADJUST": 8-2150425-5
- 5. ADJUSTMENT OF THE STRIPPER MAY BE REQUIRED WHEN MOVING THE APPLICATOR BETWEEN BENCH AND LEADMAKER APPLICATIONS.
- APPLY PART NUMBER 1-23419-5 LOCTITE TO THREADS OF ITEM 62 & 180. APPLY PART NUMBER 2-23419-6 LOCTITE TO THREADS OF ITEM 180 & 242.
- GREASE THREADS, GROOVE AND O-RING ON ITEMS 139 & 153.
- MAGNET, ITEM 166 MUST BE ORIENTED CORRECTLY IN ORDER TO PROPERLY ACTUATE THE COUNTER.
- CRIMP HEIGHT REFERENCE SETTING WAS THE SETTING USED WHEN THE APPLICATOR WAS QUALIFIED AT THE FACTORY. ADJUSTMENT MAY BE NECESSARY WHEN RUNNING APPLICATOR IN THE FIELD.
- SPARE FEED CAM STORAGE LOCATION REFER TO INSTRUCTION SHEET FOR ADDITIONAL INFORMATION.
- THE RECOMMENDED SET-UP FOR END FEED APPLICATORS IS POST-FEED WITH ITEM 2119653-1. THE APPLICATOR CAN BE CONFIGURED FOR PRE-FEED WITH ITEM 2119652-1 BUT MAY ENCOUNTER PROBLEMS WITH SOME APPLICATIONS. FEED ISSUES OR TERMINAL JAMMING MAY OCCUR IN THE PRE-FEED CONFIGURATION.
- ITEM #261 FOR (2)18 AWG WIRE SIZES. ITEM #3 FOR ALL OTHER WIRE SIZES.

***WARNING**
 ON INSTALLATION, SET WIRE DISC, ITEM 40 TO LARGEST WIRE SIZE SETTING. USE OF SETTINGS BELOW MINIMUM REQUIRED CRIMP HEIGHT SETTING WILL CAUSE DAMAGE TO CRIMP TOOLING.

ITEM NO	DESCRIPTION	ITEM NO
261	CRIMPER, INSULATION F	261
251	FINE ADJUST HEAD ASM, PACIFIC STYLE	251
250	PUSH ROD, AIR FEED	250
249	BUSHING, LCH5-12, MISUMI	249
246	SPRING, COMPRESSION	246
244	CAM, SNAIL, INSULATION ADJUSTMENT	244
243	WASHER, WAVE SPRING, CREST-TO-CREST	243
242	RETAINER, INSULATION DIAL	242
240	SHCS, LOW HEAD, RoHS, M5 X 10	240
-77-27-25-22-21	PART NO	DESCRIPTION

PACIFIC VERSION
 Shown on sheets 3 of 4 & 4 of 4
 (Atlantic version shown on sheets 1 of 4 & 2 of 4)

SET UP GAUGE	LOC	DIST	REVISIONS			
2119599-2	A	66	REV	DATE	BY	APPV
			-	SEE SHEET 1	-	-

-	-	-	-	1	2119580-1	MECHANICAL FEED ASSEMBLY	239
-	-	-	-	1	2063440-1	AIR FEED MODULE	238
-	-	-	-	1	2119740-2	TAG, IDENTIFICATION	213
-	4	4	4	4	2079383-9	SCR, BHSC, RoHS (M6 X 20)	186
-	-	REF	-	-	1901697-1	FEED FINGER ASSEMBLY, EF	183
-	-	-	-	1	1-1976055-3	STANDOFF, HOLD-DOWN	180
-	-	-	-	1	6-993111-6	PIN, SLOTTED SPRING 3.0 X 14.0	177
-	-	-	-	1	8-22280-7	SPRING, COMPRESSION	176
-	-	-	-	1	1752353-2	GUIDE PIN, HOLDDOWN	175
-	-	-	-	1	1901680-2	GUIDE PIN, HOLDDOWN	174
-	-	-	-	2	21045-3	RING, RETAIN, EXTERN, 3/16 CRESCENT	172
-	-	-	-	1	994969-1	MAGNET, RARE EARTH HIGH ENERGY	166
-	-	REF	REF	REF	994970-2	COUNTER, MAGNETIC	164
-	-	-	-	1	240638-1	SPRING, FEED FINGER	163
-	-	-	-	1	8-21084-1	O-RING, .801 ID, .070 DIA. MAT.	153
-	-	-	-	1	2119641-2	FEED CAM, AIR FEED	152
-	-	-	-	1	2119798-2	DETENT PIN	145
-	-	-	-	1	2079383-8	SCR, BHSC, RoHS (M4 X 16)	144
-	-	-	-	1	2119653-2	FEED CAM, POST FEED	142
-	-	-	-	1	2119655-6	APPLICATOR BASIC ASSEMBLY, EF	141
-	-	-	-	1	2119651-1	RAM, ASIAN STYLE, END FEED	140
-	-	-	-	1	2119092-2	BOLT, ADJUSTMENT	139
-	-	-	-	1	3-23627-7	PIN, RETAIN, GRVD, 3/16 X .854	137
-	-	REF	-	-	SEE NOTE 4	MEMORY CHIP, PROGRAMMED	135
-	-	-	-	1	1633743-1	SERVO FEED LATCH ASM	133
-	-	-	-	1	2119955-2	ASSY, LUBRICATOR, END FEED	84
-	-	-	-	1	455888-4	SPACER, CRIMPER	82
-	-	-	-	1	2119956-2	DOCUMENTATION PACKAGE	71
-	-	-	-	2	2-18032-2	SCR, SET, FLT POINT M3 X 10.0	70
-	-	-	-	1	2119740-1	TAG, IDENTIFICATION	67
-	-	-	-	2	2168078-1	SCREW, DRIVE, RH, RoHS, 2 x .188	66
-	-	-	-	1	1901681-1	HOLDDOWN, TERMINAL	65
-	-	-	-	2	2168400-5	SHCS, LOW HEAD, RoHS, M4 X 20	64
-	-	-	-	1	2119793-1	LIMITER, ADJUSTMENT BOLT	63
-	-	-	-	3	992763-5	SCR, SET, SOC, CONE POINT, M3 X 4.0	62
-	-	-	-	1	5-18022-5	SCR, HEX HD CAP, M4 X 6.0	59
-	-	-	-	1	2063961-1	FEED FINGER	58
-	-	-	-	3	2168400-4	SHCS, LOW HEAD, RoHS, M4 X 8	57
-	-	-	-	2	1-2168083-0	SCR, SKT HD CAP, RoHS, M4 X 10	56
-	-	-	-	2	5018030-2	NUT, HEX, REG, RoHS, M4	55
-	-	-	-	2	5018030-1	NUT, HEX, REG, RoHS, M3	54
-	-	-	-	2	986965-8	NUT, LOCK, HEX, TORQUE (M4)	53
-	-	-	-	1	1-5018030-0	NUT, HEX, REG, RoHS, M3.5	52
-	-	-	-	1	2119792-2	PAWL, EF, AIR	51
-	-	-	-	1	18023-9	SCR, SKT HD CAP M4 X 6.0	49
-	-	-	-	1	2119652-1	FEED CAM, PRE FEED	48
-	-	-	-	1	2079383-7	SCR, BHSC, RoHS (M8 X 25)	41
-	-	-	-	1	2119645-1	DISC, NUMBERED FA WIRE ADJUSTMENT	40
-	-	-	-	1	2119957-1	APPLICATOR SHIM PACK	39
-	-	-	-	1	2119644-2	RAM WASHER, PRECISION	38
-	-	-	-	7	1-18028-2	WASHER, FLAT, REG M4	33
-	-	-	-	2	2079383-5	SCR, BHSC, RoHS (M4 X 20)	31
-	-	-	-	2	1-2168083-0	SCR, SKT HD CAP, RoHS, M4 X 10	29
-	-	-	-	1	240639-1	STRIPPER (MACHINING)	27
-	-	-	-	2	1320906-1	STUD, THREADED	25
-	-	-	-	1	1752371-5	PLATE, STRIP GUIDE	24
-	-	-	-	1	240825-8	PLATE, STRIP HOLD DOWN	23
-	-	-	-	2	2-22281-3	SPRING, COMPRESSION	22
-	-	-	-	1	1752373-4	DRAG	20
-	-	-	-	2	1901259-6	GUIDE, LOWER STRIP	18
-	-	-	-	1	240641-9	SPACER	16
-	-	-	-	1	1752360-1	SPACER, HOLD-DOWN	13
-	-	-	-	1	240644-9	PLATE, REAR SHEAR	11
-	-	-	-	-	-	-	10
-	-	-	-	1	5-690482-9	PLATE, FRONT SHEAR	9
-	-	-	-	1	4-1803000-6	ANVIL, COMBINATION, END FEED	8
-	-	-	-	1	1-2217206-3	BLADE, SLUG	7
-	-	-	-	-	-	-	6
-	-	-	-	1	240641-8	SPACER	5
-	-	-	-	1	238009-1	BLOCK, FL CRIMPER SPACER	4
-	-	-	-	1	3-1803016-4	CRIMPER, INSULATION F	3
-	-	-	-	1	1-455888-2	SPACER, CRIMPER	2
-	-	-	-	1	456425-8	CRIMPER, WIRE .140 F PREMIUM	1
-77-27-25-22-21	PART NO	DESCRIPTION	ITEM NO				

DIMENSIONS: mm		TOLERANCES UNLESS OTHERWISE SPECIFIED:		DWG: X.ZHAO 14MAR2014		CHK: L.ZHANG 14MAR2014		APV: T.FELBIN 14MAR2014		NAME: Ocean End Feed Applicator	
0 PLC ±.05		1 PLC ±.03		2 PLC ±.013		3 PLC ±.010		4 PLC ±.008		SIZE: A1	
ANGLES ±.0001		FINISH: .		WEIGHT: .		SCALE: 1:1		SHEET: 3 OF 4		REV: B	
Customer Accessible Production Drawing										RESTRICTED TO: .	

LOC		DIST		REVISIONS			
A	66	P	LTM	DESCRIPTION	DATE	OWN	APVD
		-	-	SEE SHEET 1	-	-	-

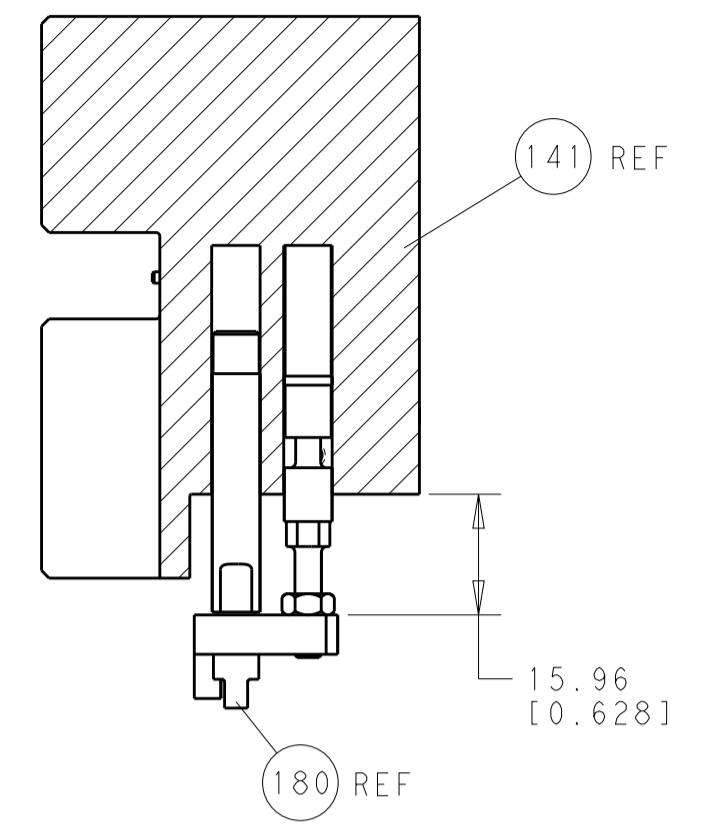

HOLDDOWN SET-UP

FEED TYPE
MECHANICAL

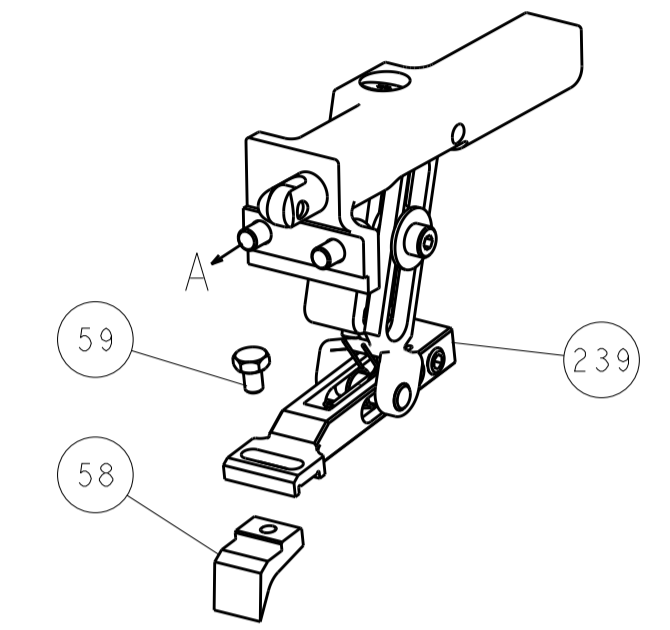

PNEUMATIC

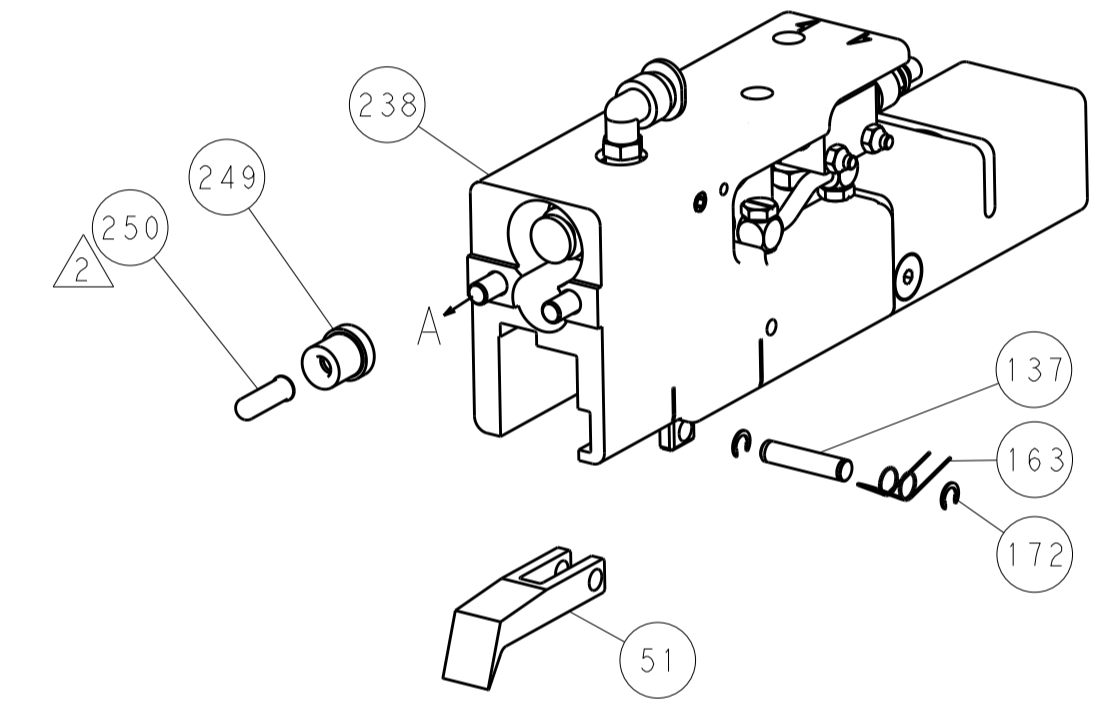

SERVO LATCH PLATE

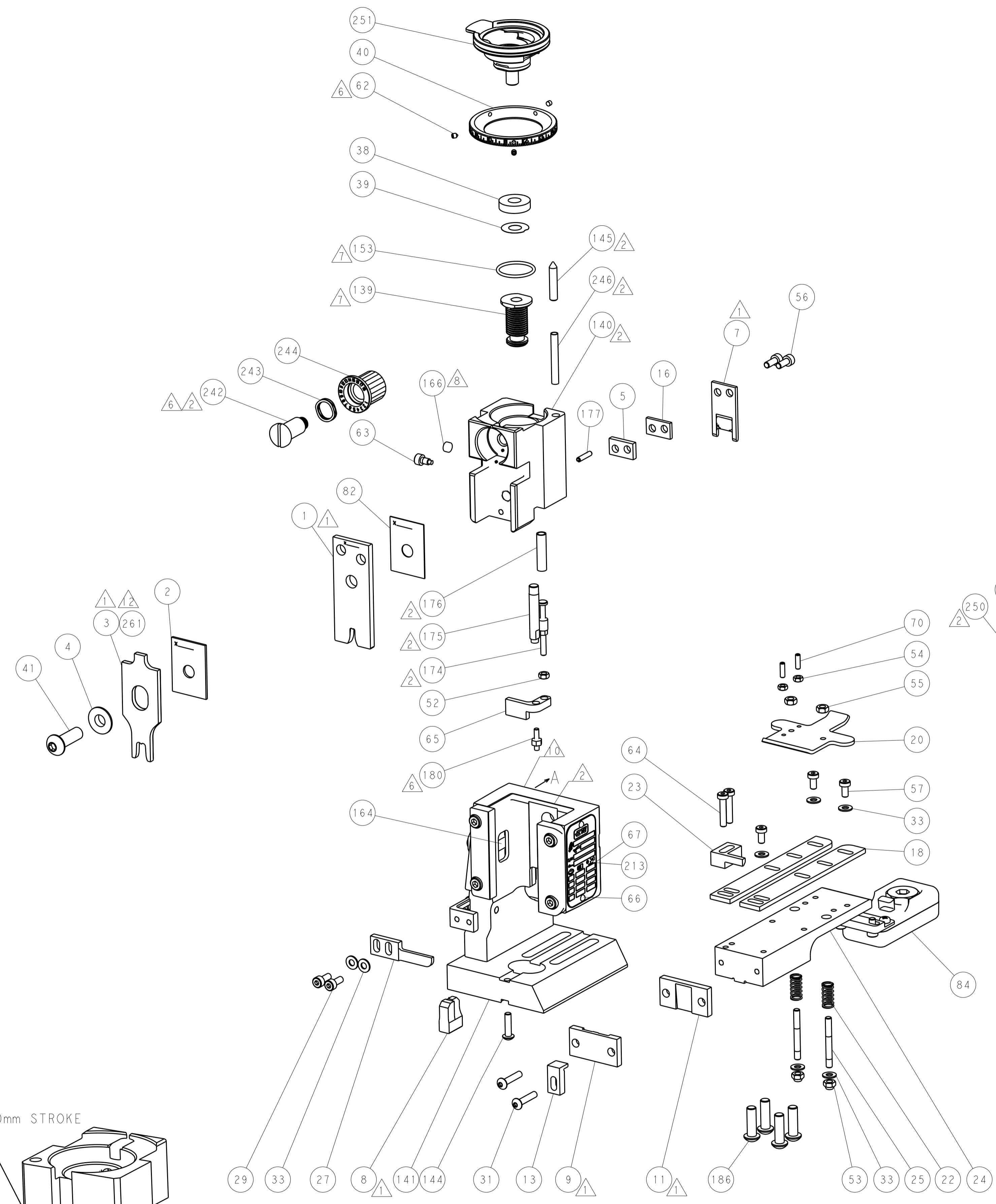
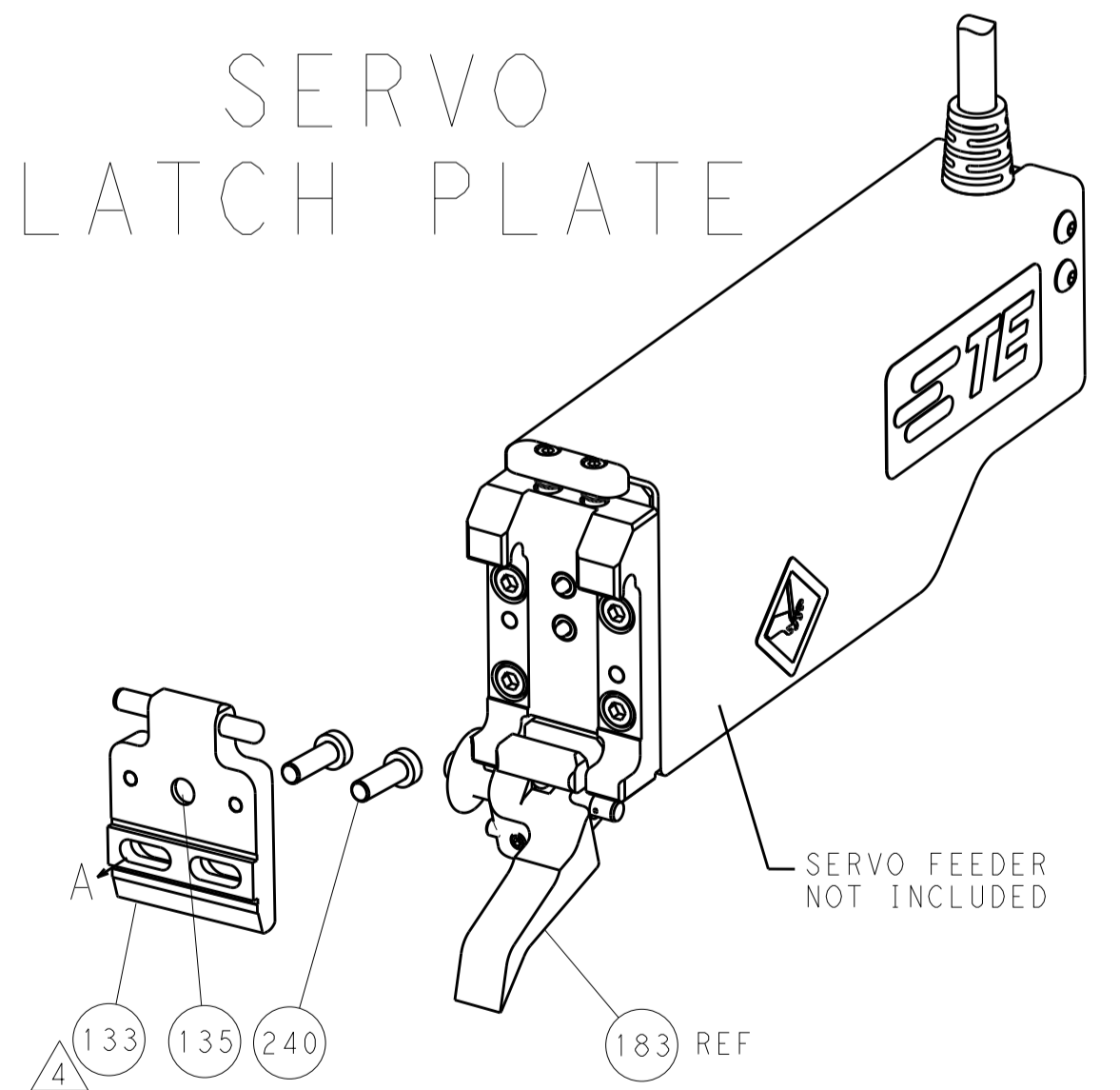

CAM POSITIONS

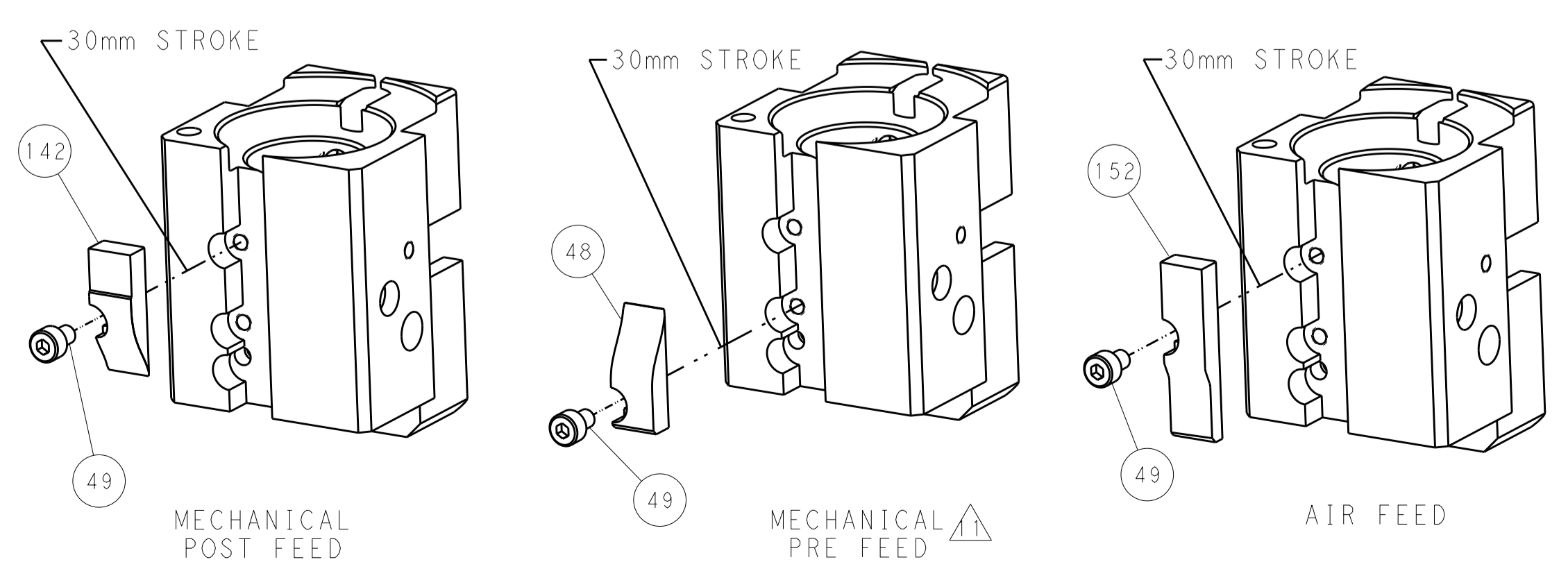

PACIFIC VERSION
 Shown on sheets 3 of 4 & 4 of 4
 (Atlantic version shown on sheets 1 of 4 & 2 of 4)

DIMENSIONS:		TOLERANCES UNLESS OTHERWISE SPECIFIED:		DWN: X. ZHAO 14MAR2014		CHK: L. ZHANG 14MAR2014		APVD: T. ELBIN 14MAR2014		NAME: Ocean End Feed Applicator	
mm	0 PLC ±0.5	1 PLC ±0.13	3 PLC ±0.013	4 PLC ±0.001	PRODUCT SPEC		APPLICATION SPEC		SIZE: CAGE CODE DRAWING NO: A11 00779 C=2150425		
MATERIAL:	FINISH:	WEIGHT:		SCALE: 1:1		SHEET 4 OF 4		REV B		RESTRICTED TO:	