

Miniature Lightweight High Density Connectors





## Contents

Overview .....	4
Features and benefits .....	5 - 6
Comparison with high density D-Sub .....	7
Comparison with micro-D .....	8
Technical Features .....	9 - 12
Weight - Mating Forces .....	12
Contact layouts .....	13
Contact types .....	14
Ordering information .....	15
Crimp removable contacts .....	16
Mating dimensions and contact position .....	17
Wiring instructions .....	17 - 18
Dimensions .....	19 - 21
Mounting operations and hardware .....	22 - 27
Mounting hardware .....	28 - 31
Hermetic feedthrough .....	32 - 34
EMI Backshells .....	35 - 38
Dust Caps .....	39
Under development .....	40



## Overview

### Description

To respond to miniaturization and weight saving trends in aeronautical and defense applications SOURIAU has developed an innovative high density connector range: *microComp®* is the alternative to High Density (HD), D-Sub and micro-D.

- Very light: shell in composite (or aluminum). Up to 66% lighter than HD/D-Sub
- Very high density up to 40% smaller than HD D-Sub
- With crimp removable contacts for wire AWG 24 to 28
- Temperature up to 175°C
- High vibration and shock withstanding
- Standard MIL-STD 83513 accessories
- Compatible with high speed data rates (Gigabit Ethernet...)



### Applications

For civil aviation, military aircraft, rotorcraft, UAV and military equipment:

- Radar
- Engine Control Unit
- Missiles & Weapon systems
- Flight test equipment
- Data acquisition equipment
- Cockpit equipment & Avionics
- In Flight Entertainment Systems
- Displays
- Infrared cameras
- Battery management system
- ... and any electronic device with space and weight constraints



For space applications please consult our dedicated Space Grade *microComp®* catalog



## Features and benefits

### Composite Shell Benefit

microComp® shells are available in strengthened fiber glass material for a maximum mechanical resistance. Composite shells are up to 36% lighter than aluminum shells.

The advanced «Nickel over composite» plating process used on microComp® has been qualified on SOURIAU MIL-DTL-38999 product range (technology selected by Boeing and Airbus, provides optimized shielding and shell-to-shell continuity).

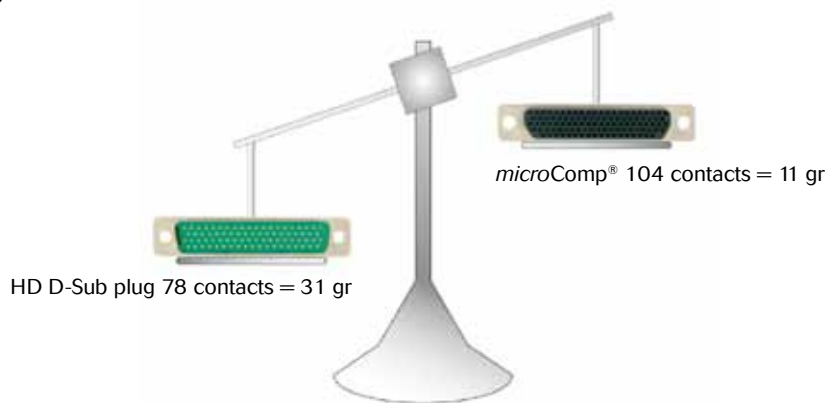

### microComp® male contacts are protected

microComp® male connectors are tamper proof. On HD D-Sub and D-Sub male contacts are the fragile parts of the connector because they can easily be bent. On microComp® male contacts are fully shrouded by the insulator: they are protected and can't be bent.

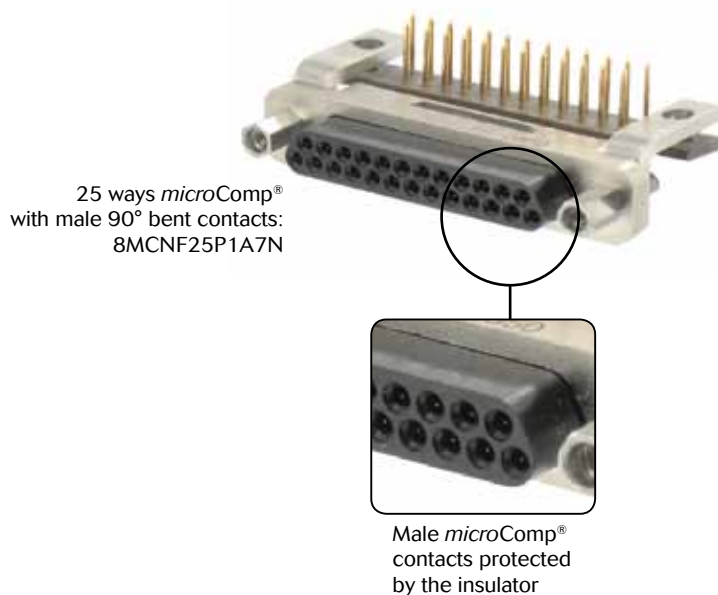
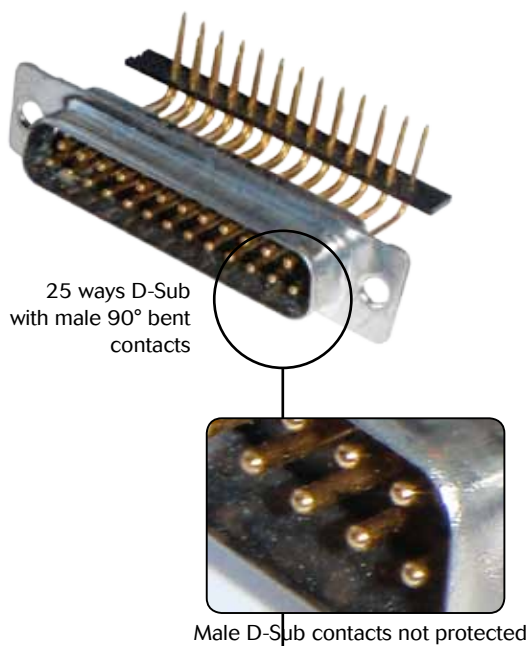



## Features and benefits

### Ethernet performances

With its very short contacts, *microComp*® has very good performances for Ethernet.

#### Fully Ethernet 100 base T compatible :

Fit up to 4 Ethernet links into a 25 ways *microComp*®  
 Compatible with standard Ethernet Quad wires  
 Reach up to cat 6 performances (TIA/EIA 568-B)

#### Fully Ethernet 1000 base T compatible :

Fit up to 2 Ethernet links in to a 25 ways *microComp*®  
 No need to ground the pins between the quads.  
 Reach cat 5e performances (TIA/EIA 568-B)



1 quad		> Cat 6
N quad with segregation		> Cat 5e
N pairs with segregation		Cat 6



Exemple of configuration: 4 quad + 1 contact for signal in a size F shell

Please consult us ([microcomp@souriau.com](mailto:microcomp@souriau.com)) for more information about the wiring for Ethernet links



## Comparison with high density D-Sub

### microComp® benefits:

**Save room and weight on your equipment:** for signal applications, replace your HD D-Sub with *microComp*® and reduce your equipment dimensions and weight.

### HD D-Sub



26 cts



44 cts



78 cts

### microComp®



25 cts



51 cts



104 cts

### Size comparison: *microComp*® is smaller

Comparison between the max dimensions given in *microComp*® standard (ESCC 3401/081) and in HD D-Sub standard (MIL-DTL 24308).

	<i>microComp</i> ®	HD-DSub	<i>microComp</i> ®	HD-DSub	<i>microComp</i> ®	HD-DSub
Number of contacts	25	26	51	44	104	78
Front dimension (max)	2,9 cm <sup>2</sup>	5,1 cm <sup>2</sup>	4,3 cm <sup>2</sup>	6,9 cm <sup>2</sup>	7,8 cm <sup>2</sup>	12,1 cm <sup>2</sup>
Size saving / HD Dsub	-42%		-37%		-35%	
Surface per contact	11,8 mm <sup>2</sup>	19,7 mm <sup>2</sup>	8,5 mm <sup>2</sup>	15,7 mm <sup>2</sup>	7,5 mm <sup>2</sup>	11,6 mm <sup>2</sup>
Size saving per contact / HD Dsub	-40%		-46%		-35%	

### Weight comparison: → *microComp*® is lighter

Comparison between the max weight given in *microComp*® standard (ESCC 3401/081, 082, 083) and in HD D-Sub standard (ESCC 3401 001/002/005).

	<i>microComp</i> ®	HD-DSub	<i>microComp</i> ®	HD-DSub	<i>microComp</i> ®	HD-DSub
Number of contacts	25	26	51	44	104	78
Plug without cable	3,60 gr	9,48 gr	6,01 gr	14,52 gr	10,99 gr	31,32 gr
Receptacle with 90° spills	4,60 gr	14,00 gr	8,39 gr	22,14 gr	17,54 gr	51,04 gr
Average weight per contact	0,33 gr	0,90 gr	0,28 gr	0,83 gr	0,27 gr	0,79 gr
Weight saved per contact with <i>microComp</i> ® (%)	-64%		-66%		-65%	

### Mating force comparison: → *microComp*® is easier to mate and unmate

even with more than 100 contacts.

Comparison between the max mating/unmating force given in *microComp*® standart (ESCC 3401/081) and in HD D-sub standard (MIL-DTL 24308)

	<i>microComp</i> ®	HD-Dsub	<i>microComp</i> ®	HD-Dsub	<i>microComp</i> ®	HD-Dsub
Number of contacts	25	26	51	44	104	78
Max mating/unmating force (N)	43N	76N	87N	125N	179N	289N
Difference in N	33N		38N		110N	
Saving in %	-44%		-30%		-38%	



## Comparison with micro-D

### microComp® benefits:

**Save money:** global cost of ownership is less expensive for *microComp*® than for micro-D. With micro-D any change in design or quality issue leads to complete harness replacement as micro-D are pre-wired and non repairable. *microComp*® solution is more flexible thanks to the removable crimp contacts.

**Save time in development:** *microComp*® has removable crimp contacts so you can easily and quickly change your harness configuration.

**Save weight:** the high technology composite shells (strengthened fiber glass material for maximum mechanical resistance) makes *microComp*® very light and robust.

**Same panel cut-out:** *microComp*® connectors have the same external dimensions as MIL-DTL 83513 (except for size H and J).

**Easier to use:** mating and unmating force is lower for *microComp*® than for micro-D.

### Weight comparison: → *microComp*® is lighter

Comparison between the max weight (connector + contacts) given in *microComp*® standard (ESCC 3401/081, 082, 083) and in micro-D standard (ESCC 3401/029).

	<i>microComp</i> ®	micro-D	<i>microComp</i> ®	micro-D	<i>microComp</i> ®	micro-D
Number of contacts	7	9	25	25	51	51
Plug without cable	1,42 gr	2,20 gr	3,60 gr	4,30 gr	6,01 gr	7,20 gr
Receptacle with 90° spills	1,68 gr	7,40 gr	4,60 gr	10,20 gr	8,39 gr	16,50 gr
Average weight per contact	0,44 gr	1,07 gr	0,33 gr	0,58 gr	0,28 gr	0,46 gr
Weight saved per contact with <i>microComp</i> ® (%)	-58%		-43%		-39%	

Note: No comparison with MIL-DTL 83513 standard because no max weight are given in this standard.

### Mating force comparison: → *microComp*® is easier to mate and unmate

even with more than 100 contacts.

Comparison between the max mating and unmating force given in *microComp*® standard (ESCC 3401/081, 082, 083) and in micro-D standard (MIL-DTL 83513).

	<i>microComp</i> ®	micro-D	<i>microComp</i> ®	micro-D	<i>microComp</i> ®	micro-D	<i>microComp</i> ®	micro-D
Number of contacts	7	9	25	25	51	51	104	100
Max mating/unmating force (N)	12N	25N	43N	87N	41N	144N	179N	283N
Difference in N	14N		28N		58N		104N	
Saving in %	-53%		-40%		-40%		-37%	



## Technical characteristics

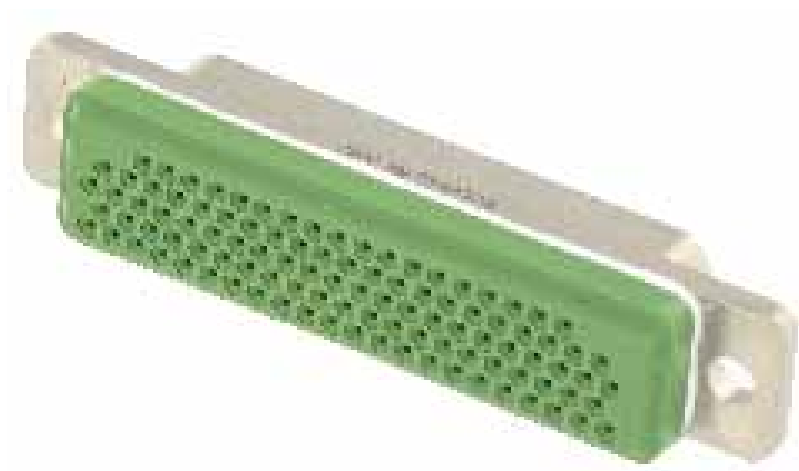

### Electrical

- Contact size: #26
- Contact pitch: 2 mm
- Current rating: 2.5 Amps
- Dielectric Withstanding Voltage  
sea level: 600 VRMS  
70.000 feet: 200 VRMS
- Insulation resistance: 5,000 MΩ
- Low level contact resistance: 6 mΩ
- Rated current contact resistance: <5 mΩ
- Admissible wire gauge: AWG 24 to 28
- Shielding effectiveness: > 60dB attenuation  
from 1 to 500 MHz
- Shell to shell continuity:  
Composite version: < 2mΩ  
Aluminum version: < 2mΩ

### Mechanical

- Endurance / Durability:  
500 mating/unmating operations
- Contact retention in insert: 15 N
- Vibration:  
Random: 44g  
Sine: 20g
- Shock: 50g

### Climatic

- Operating temperature range:  
-55°C to +175°C
- Storage temperature range  
-65°C to +125°C
- Soldering temperature: +260°C
- Salt spray (corrosion):  
Composite shell: 2000 hrs  
Aluminum shell: 48 hrs
- Flammability: UL 94V-0  
(self-extinguishing materials)

### Material and finishes:

- Shell: composite (glass fiber reinforced)  
material for maximum mechanical resistance)  
or Aluminum
- Shell plating: 10μ Ni over Cu
- Contact: copper alloy
- Contact plating: 1.27 μm (50 μin) Au  
according to Type 2, Grade C of MIL-DTL-45204
- Insulator: thermoplastic
- Mounting accessories (Jackscrews, jackposts,  
clip): stainless steel, passivated per QQ-P-35
- Grommet and seal: silicone rubber
- Drilled bar: thermoplastic

### Environmental

- RoHS: compliant



## Technical features

### Detailed performances

Mechanical			
Description	Requirement	Test method	
Endurance / Durability	500 mating/unmating operations Connectors shall meet contact resistance, insulation resistance, DWV, mating and unmating force	MIL-DTL 83513 8 cycles/minute maximum	
Insert retention in shell	34,4 N/cm <sup>2</sup> (50 psi)	MIL-DTL 83513	
Tensile test	F>60N for #24 cable, F>45N for #26 cable and F>30N for #28 cable	SAE AS-39029	
Vibration	No discontinuity > 1µs, no cracking, breaking or loosening of parts, plug shall not become disengaged from receptacle. Connectors shall meet electrical requirements after vibration test.	Random: 44g	IEC 60068-2-35, test Fda (8h x 3 axis, f1 = 20Hz, f2 = 2000Hz)
		Sine: 20g	IEC 60512-4 test 6d (30min x 3 axis, 10Hz-2000Hz)
Shock and Bump	No discontinuity > 1µs, no cracking, breaking or loosening of parts, plug shall not become disengaged from receptacle. Connectors shall meet electrical requirements after shock and bump tests.	Shock: 50g for 11ms	IEC 60512-4 6c (3 shocks x 3 axis x 2 directions = 18 shocks)
		Bump: 390 m/s <sup>2</sup>	IEC 60512-4 6b (4,000 ± 10 bumps x 3 axis x 2 directions = 24,000 bump)
Contact insertion/ removal endurance	Contact insertion and withdrawal forces < 13.5 N Contact retention in insert > 15 N	9 cycles insertion/removal	
Probe damage	Separation force mini > 0.14 N	IEC 60512-8 test 16A bending moment = 0.9 Ncm	
Contact retention in insert	>15 N	An initial force of 10N shall be applied to the engagement end of the contact. Then a force at a rate not exceeding 5N per sec shall be applied: displacement shall then be measured from the insert face with the contact under load and it shall not exceed 0,3 mm (.012 in) at the required force.	
Max engagement force	1,66 N	The maximum diameter test pin or minimum diameter test sleeve shall be engaged to 70% of the depth of the female mating cavity or length of the engagement male contact and separate 3 times. The engagement and separation forces shall be measured on the third engagement and separation.	
Min separation force	0,14 N		



## Technical features

### Detailed performances

Electrical		
Description	Requirement	Test method
Dielectric Withstanding Voltage (2mA leakage current max) sea level	600 VRMS	MIL-DTL 83513 EIA-364-20
Dielectric Withstanding Voltage (2mA leakage current max) 70,000 feet	200 VRMS	MIL-DTL 83513 IEC 60512 test 4a methB
Insulation resistance	5,000 MΩ	MIL-DTL 83513 EIA-364-21 IEC 60512 test 3a methB MIL-STD 202 test meth 302
Low level contact resistance	6 mΩ	MIL-DTL 83513 EIA 364-06 MIL-STD 202 Meth 307
Rated current contact resistance	5 mΩ	
Overload test	Temperature < 100°C	A current of 3 Amp for AWG 26 and AWG 28 are passed through all contacts of mated connectors for 30s. This was followed by a period of 90 s with no current flowing. This constitutes 1 cycle. The cycle has been repeated 5 times (10 minutes in total).
Shielding effectiveness	>60dB attenuation from 1 to 500 MHz	IEC-60512-23-3
Shell to shell continuity	Composite version < 2mΩ Aluminum versions < 2mΩ	EIA 364-83 EN2591-205

Climatic		
Description	Requirement	Test method
Dry heat	At 125 °C : insulation resistance > 5,000MΩ at 500 VDC	IEC 60068-2-2 test Ba 2 hours at 175°C with sudden change of temperature.
Climatic sequence: Dry heat / Damp heat 1 / Cold test / Low air pressure / Damp heat 2	No breakdown or flashover during low air pressure test, mated and unmated at 150VAC  Insulation resistance > 100 MΩ at 500VDC just after Damp heat 2 test	Dry heat: IEC 60068-2-2 test Ba (2 hours at 175°C with sudden change of temperature) Damp heat: IEC 60068-2-30 test Db severity b Cold test: IEC 60068-2-1 test Aa (2 hours at -65°C with sudden change of temperature) Low Air Pressure: IEC 60068-13 test M (33,000m = 108,000 ft)
Storage temperature range	-65°C to +125°C	IEC 60512-6 test 11i for 1.000 h at +125°C
Soldering temperature	+260°C	EIA-364-56 Procedure 3 Test Condition B
Salt spray (corrosion)	No corrosion on the interfaces or mating surfaces after 2000 hours for composite shell and 48 hours for Aluminum shell.	IEC 60068-2-11 test Ka



## Technical features

### Detailed performances

Others		
Description	Requirement	Test method
Residual Magnetism	< 200 gamma	ESA ESCC 3401 / 9.5
Permanence of marking	No deterioration after 3 immersions of 1mn in solvent with 10 brushings after each immersion	MIL-STD 202 meth 215

## Weight

Composite shells are up to 36% lighter than aluminum.

Shell max weight* in g (oz)				
	Composite version		Aluminum version	
	Male	Female	Male	Female
A	1.05 (0.037)	1 (0.035)	1.35 (0.048)	1.45 (0.051)
B	1.35 (0.048)	1.25 (0.044)	1.75 (0.062)	1.8 (0.063)
C	1.6 (0.056)	1.45 (0.051)	2.15 (0.076)	2.2 (0.078)
D	1.8 (0.063)	1.65 (0.058)	2.35 (0.083)	2.4 (0.085)
E	2.1 (0.074)	1.88 (0.066)	2.7 (0.095)	2.69 (0.095)
F	2.35 (0.083)	2.1 (0.074)	2.95 (0.104)	2.9 (0.103)
G	2.5 (0.088)	2.2 (0.078)	3.15 (0.111)	3.05 (0.108)
H	3.44 (0.121)	2.95 (0.104)	4.2 (0.148)	4.1 (0.145)
J	6.1 (0.215)	4.75 (0.168)	7.3 (0.257)	6.45 (0.228)

\* without contact

Contact max weight in g (oz)		
Contacts	Male	Female
Crimp contacts	0.04 (0.0014)	0.06 (0.0021)
Straight PC tails (spills) contacts	0.08 (0.0028)	
90° PC tails (spills) contacts for shell size A to F*	0.09 (0.0032)	
90° PC tails (spills) contacts for shell size G and H*	0.097 (0.0034)	
90° PC tails (spills) contacts for shell size J*	0.11 (0.0039)	

\* average weight

## Mating forces

Shell sizes									
	A	B	C	D	E	F	G	H	J
Mating force max (N)	11.9	18.7	22.1	28.9	35.7	42.5	56.1	86.7	178.8



## Contact layouts

Shell size	Number of contacts	Front view of male insert
A	7	
B*	11	
C*	13	
D*	17	
E*	21	
F	25	
G*	33	
H	51	
J	104	



Contact size: #26

Contact pitch: 2.0 mm

\* Consult us for availability.

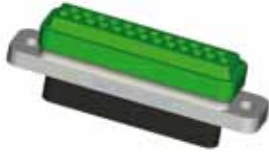

## Contact types

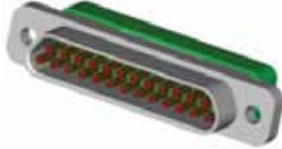
Crimp	Unsealed	Sealed
	Male (-P011 and -P011B)	Male with grommet (-E-P011 and -E-P011B)
		
	Female (-S011 and -S011B)	Female with grommet and interfacial seal (-E-S011 and -E-S011B)
		

Straight PCB	Straight PCB	
	Male (-POL3)	
		
	Rear view	

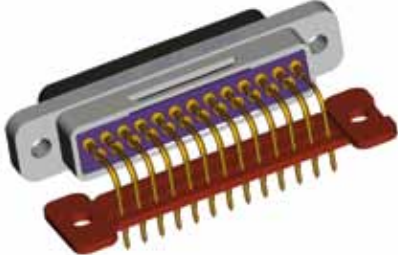
90° bent PCB	Male without fixing accessories (-P1A0N)	Male with standard jackposts (-P1A7N)
		
	Rear view	Rear view



## Ordering information

### MIL/AERO part-numbering system

MIL/Aero series - PCB versions		BMC	N	F25	P	1A7N
Shell material:	<b>None:</b> composite <b>A:</b> aluminum					
Version:	<b>N:</b> MIL grade (electroless Nickel finish) <b>None:</b> without plating <i>For Space Grade plating (gold) - consult our Space Grade microComp® catalog</i>					
Environment:	<b>E:</b> sealed version <i>With P1AxN termination: non standard, consult us</i> <i>With POL3 termination: non standard, consult us</i> <b>T:</b> sealed version, interfacial seal only <i>The interfacial seal is always on the female connector (-S- contact type)</i> <b>None:</b> no sealing					
Shell size & contact layout:	<b>A7:</b> 7 contacts <b>B11:</b> 11 contacts* <b>C13:</b> 13 contacts* <b>D17:</b> 17 contacts* <b>E21:</b> 21 contacts* <b>F25:</b> 25 contacts <b>G33:</b> 33 contacts* <b>H51:</b> 51 contacts <b>J104:</b> 104 contacts					
Contact type:	<b>P:</b> Pin contacts for male connector <b>S:</b> socket contacts for female connector					
Termination code:	<b>OL3:</b> Straight PCB contacts <b>1A0N:</b> 90° bent PCB contacts, without bracket, with removable drilled bar, 2,54 mm pitch between rows <b>1A7N:</b> 90° bent PCB contacts, 2,54 mm pitch between rows, with bracket, removable drilled bar and standard jackpost					

MIL/Aero series - Crimp versions		BMC	N	E	F25	S	011B
Shell material:	<b>None:</b> composite <b>A:</b> aluminum						
Version:	<b>N:</b> MIL grade (electroless Nickel finish) <b>None:</b> without plating <i>For Space Grade plating (gold) - consult our Space Grade microComp® catalogue</i>						
Environment:	<b>E:</b> sealed version <i>With P011, P011B or PL termination: grommet</i> <i>With S011, S011B or SL termination: grommet + interfacial seal</i> <b>T:</b> sealed version, interfacial seal only <i>The interfacial seal is always on the female connector (-S- contact type)</i> <b>None:</b> no sealing						
Shell size & contact layout:	<b>A7:</b> 7 contacts <b>B11:</b> 11 contacts* <b>C13:</b> 13 contacts* <b>D17:</b> 17 contacts* <b>E21:</b> 21 contacts* <b>F25:</b> 25 contacts <b>G33:</b> 33 contacts* <b>H51:</b> 51 contacts <b>J104:</b> 104 contacts						
Contact type:	<b>P:</b> Pin contacts for male connector <b>S:</b> Socket contacts for female connector						
Termination code:	<b>011:</b> Crimp contacts for wire AWG 26 & 28 <b>011B:</b> Crimp contacts for wire AWG 24 & 26 <b>L:</b> delivered without contact						

Insertion/extraction tool 8MCIET is always included with -S011, -S011B, -P011B and -P011 versions, but not with -L versions.  
Termination codes -011, -011B and -L are not marked on the connector (only for order)

**\*Consult us for availability**  
Jackscrews kits are never included



## Crimp removable contacts

MIL/Aero standards do not define #26 crimp contacts (cf AS39029). So to offer our customers a high density connector with removable contacts we have used contacts defined in ESCC space standard. ESCC 3401/083 defines the design, dimensions and performances of contacts #26 used in *microComp*®. These contacts are in copper and are gold plated. They have been designed for high electrical and mechanical performances – they withstand high shocks and vibrations. These contacts are crimped to wire using standard MIL spec crimp tool MIL-DTL-22520 and a locator for #26 contacts.

### Male contact (pin):

#26 MIL grade male contacts part numbers:		
Wire size	AWG 24-26	AWG 26-28
Part number	8MC 00 103	8MC 00101

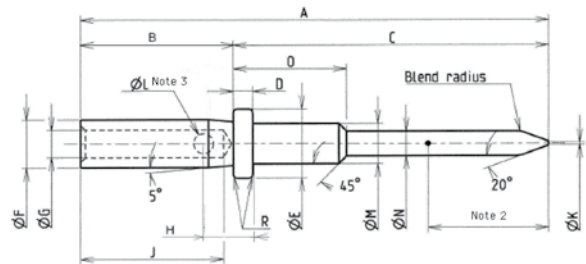

Dimensions in mm (inch)																	
	A	B	C	D	ØE	ØF		ØG		H	J	ØK	ØL	ØM	ØN	O	R
						AWG 24/26	AWG 26/28	AWG 24/26	AWG 26/28								
Min. mm (inch)	-	3,10 (.122)	6 (.236)	0,35 (.014)	1,37 (.054)	1,00 (.039)	0,92 (.036)	0,73 (.029)	0,56 (.022)	1 (.039)	2,90 (.114)	-	0,40 (.016)	0,80 (.031)	0,50 (.019)	1,85 (.073)	0,04 (.002)
Max. mm (inch)	9,80 (.386)	3,25 (.128)	6,10 (.240)	0,41 (.016)	1,41 (.055)	1,08 (.043)	0,98 (.039)	0,76 (.030)	0,60 (.024)	1,10 (.043)	3,10 (.122)	0,15 (.006)	0,50 (.020)	0,82 (.032)	0,52 (.021)	1,91 (.075)	0,08 (.003)

### Female contact (socket):

#26 MIL grade male contacts part numbers:		
Wire size	AWG 24-26	AWG 26-28
Part number	8MC 00104	8MC 00102

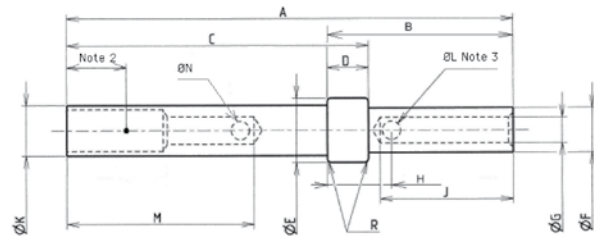

Dimensions in mm (inch)																
	A	B	C	D	ØE	ØF		ØG		H	J	ØK	ØL	M	ØN	R
						AWG 24/26	AWG 26/28	AWG 24/26	AWG 26/28							
Min. mm (inch)	-	4,05 (.159)	6,55 (.258)	0,85 (.033)	1,37 (.054)	1,00 (.039)	0,92 (.036)	0,73 (.029)	0,56 (.022)	1,40 (.055)	2,90 (.114)	1,05 (.041)	0,40 (.016)	4,10 (.161)	0,40 (.016)	0,04 (.002)
Max. mm (inch)	9,80 (.386)	4,15 (.163)	6,60 (.260)	0,91 (.036)	1,41 (.055)	1,08 (.043)	0,98 (.039)	0,76 (.030)	0,60 (.024)	1,51 (.059)	3,10 (.122)	1,13 (.044)	0,50 (.020)	4,20 (.165)	0,50 (.020)	0,08 (.003)



## Mating dimensions and contact position

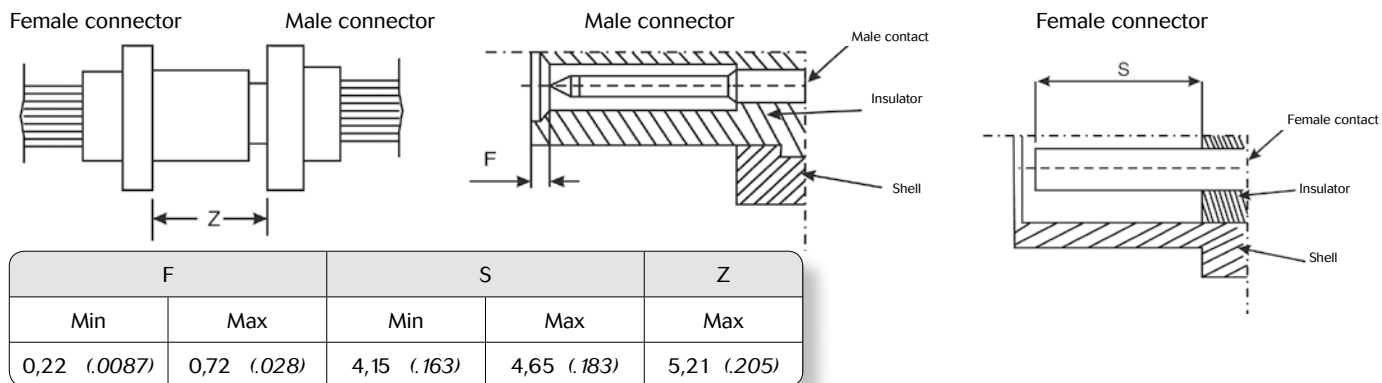

Dimensions in mm (inch)

## Wiring instructions

Insertion and extraction tool: 8MCIET

This tool for *microComp*® crimp contacts #26 is always included with crimp versions of *microComp*® connectors (except for delivery without contacts).

MIL-DTL 22520 crimp tool and specific locator:

Use standard M22520/2-01 crimp tool with the following locators:

	Male	Female
Locator P/N	8985-3093A	8985-3094A
AWG 24 - 26	Mark n°4	Mark n°4
AWG 28	Mark n°2	Mark n°2



## Cable preparation and wire stripping

L = Length of wire stripping

Contact size	L min.	L max.
# 26 mm (inch)	2,91 (.114)	3,41 (.134)

## Insertion of wire in contact barrel

When inserting the stripped wire into the contact barrel check that no strands are left outside and that the wire is visible through the wire inspection hole in the barrel

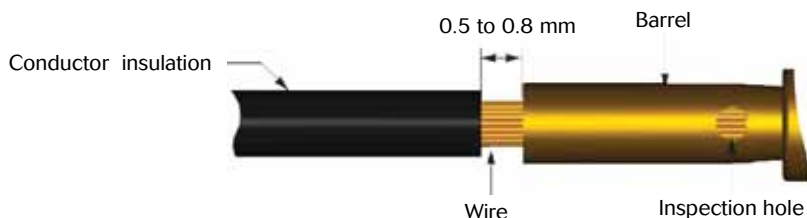



## Wiring instructions

Contacts are inserted and extracted from the rear of the connector

### Insertion of the contacts

1 - Engage the crimp cable / contact assembly into the longitudinal slot of the plastic tool 8MCIET (blue side). Slide the tool down the cable until the tip of the tool abuts the contact retention shoulder.

2 - Introduce the contact into the required contact cavity in the insulator, pushing tool axially, until the contact snaps into position in clip.

3 - Withdraw the tool (from rear). Check that contact is firmly locked by pulling wire gently. When connector is fully loaded, check the position of contact tips. They should all be in the same plane.

Nota : For cable that is stiff enough, manual insertion without tool is preferable.

### Extraction of the contacts

1 - Engage the appropriate cable into the longitudinal slot of the tool with the white tip towards connector.

2 - Slide the tool down towards the contact. Insert the tool in the insulator until it abuts the contact shoulder.

3 - Holding the tool-contact and cable assembly together, remove them simultaneously.





## Dimensions

### Female shell

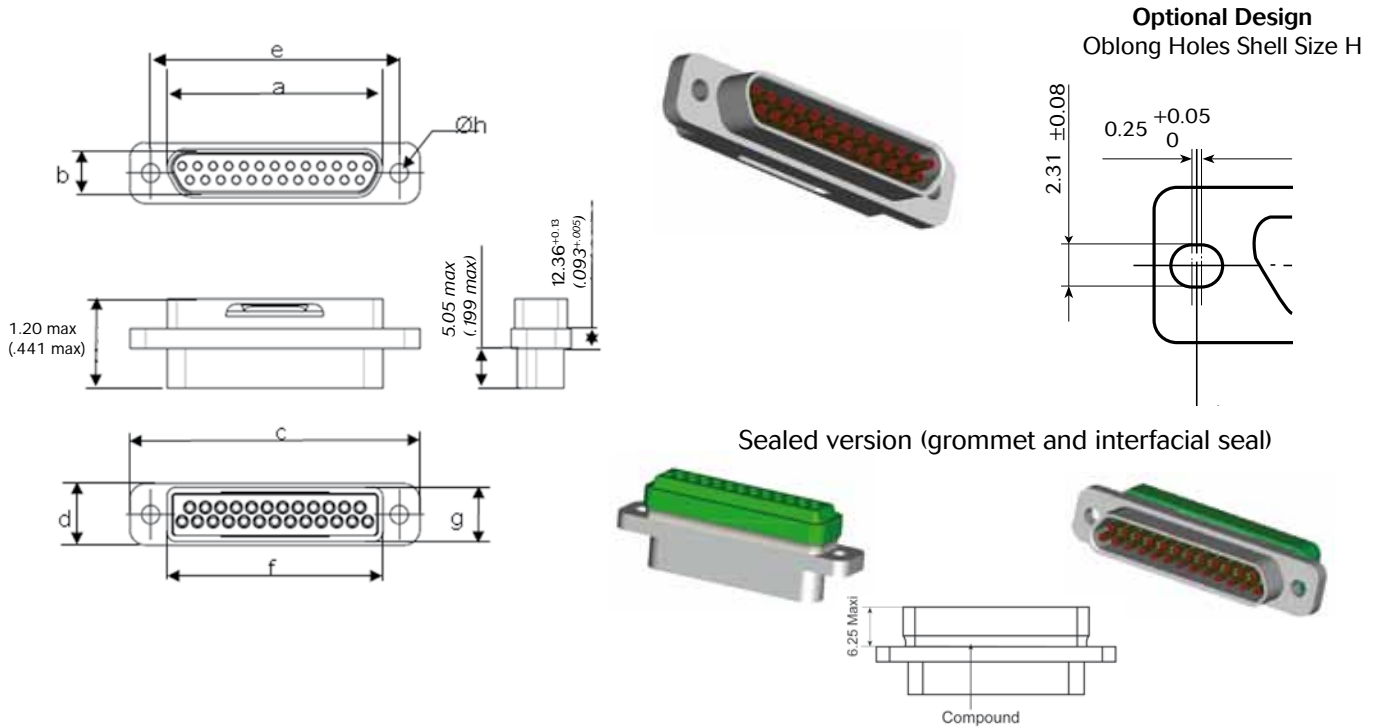

Shell Size	a	b	c		d		e		f		g	h
	Max	Max	min	Max	min	Max	min	Max	min	Max	Max	min
A	10,16 (.400)	6,38 (.251)	19,43 (.765)	19,94 (.785)	7,31 (.288)	7,82 (.307)	14,22 (.559)	14,48 (.570)	9,45 (.372)	10,16 (.400)	6,86 (.270)	2,26 (.089)
B	13,97 (.550)	6,38 (.251)	23,25 (.915)	23,75 (.935)	7,31 (.288)	7,82 (.307)	18,03 (.709)	18,29 (.720)	13,26 (.522)	13,97 (.550)	6,86 (.270)	2,26 (.089)
C	17,78 (.634)	6,38 (.251)	27,05 (1.065)	27,56 (1.085)	7,31 (.288)	7,82 (.307)	21,84 (.859)	22,10 (.870)	17,07 (.672)	17,78 (.700)	6,86 (.270)	2,26 (.089)
D	20,32 (.700)	6,38 (.251)	29,59 (1.165)	30,10 (1.185)	7,31 (.288)	7,82 (.307)	24,38 (.959)	24,64 (.970)	19,61 (.772)	20,32 (.800)	6,86 (.270)	2,26 (.089)
E	24,13 (.950)	6,38 (.251)	33,41 (1.315)	33,91 (1.335)	7,31 (.288)	7,82 (.307)	28,19 (1.149)	28,45 (1.120)	23,42 (.992)	24,13 (.950)	6,86 (.270)	2,26 (.089)
F	27,94 (1.100)	6,38 (.251)	37,21 (1.465)	37,72 (1.485)	7,31 (.288)	7,82 (.307)	32,00 (1.259)	32,26 (1.270)	27,23 (1.072)	27,94 (1.100)	6,86 (.270)	2,26 (.089)
G	26,67 (1.050)	7,47 (.294)	35,95 (1.415)	36,45 (1.435)	8,42 (.331)	8,92 (.351)	30,73 (1.229)	30,99 (1.220)	25,96 (1.022)	26,67 (1.050)	6,86 (.270)	2,26 (.289)
H	38,65 (1.521)	7,47 (.294)	48,05 (1.891)	48,55 (1.911)	8,42 (.331)	8,92 (.351)	43,23 (1.702)	43,49 (1.712)	38,40 (1.512)	38,65 (1.522)	7,87 (.310)	2,26 (.089)
J	46,80 (1.842)	10,94 (.431)	62,25 (2.451)	62,75 (2.470)	12,00 (.472)	12,50 (.492)	54,72 (2.154)	54,98 (1.377)	47,40 (1.866)	47,65 (1.876)	11,25 (.443)	3,70 (.146)

All dimensions in mm (inches)



## Dimensions

### Male shell

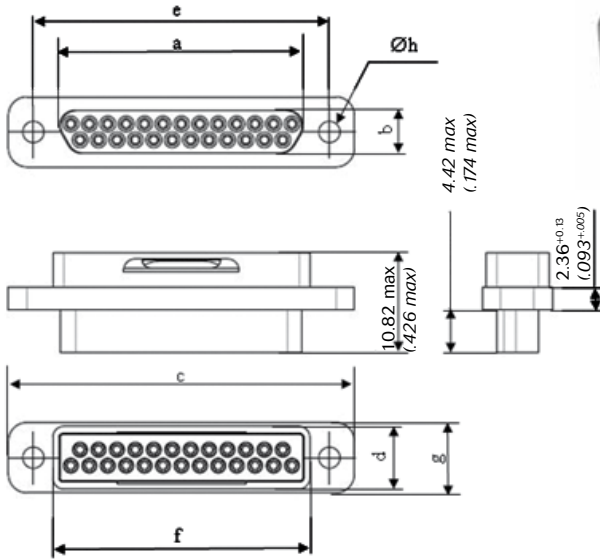

### Optional Design Oblong Holes Shell Size H

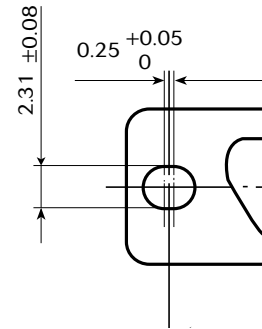

### Sealed version (with grommet)

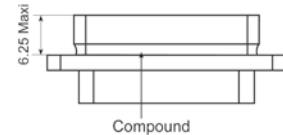
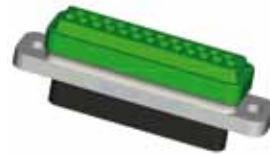

Shell size	a	b	c		d		e		f		g	h
	Max	Max	min	Max	min	Max	min	Max	min	Max	Max	min
A	8,48 (.334)	4,69 (.185)	19,43 (.765)	19,94 (.785)	7,31 (.288)	7,82 (.307)	14,22 (.559)	14,48 (.570)	9,45 (.372)	10,16 (.400)	6,86 (.270)	2,26 (.089)
B	12,29 (.484)	4,69 (.185)	23,25 (.915)	23,75 (.935)	7,31 (.288)	7,82 (.307)	18,03 (.709)	18,29 (.720)	13,26 (.522)	13,97 (.550)	6,86 (.270)	2,26 (.089)
C	16,10 (.634)	4,69 (.185)	27,05 (1.065)	27,56 (1.085)	7,31 (.288)	7,82 (.307)	21,84 (.859)	22,10 (.870)	17,07 (.672)	17,78 (.700)	6,86 (.270)	2,26 (.089)
D	18,64 (.734)	4,69 (.185)	29,59 (1.165)	30,10 (1.185)	7,31 (.288)	7,82 (.307)	24,38 (.959)	24,64 (.970)	19,61 (.772)	20,32 (.800)	6,86 (.270)	2,26 (.089)
E	22,45 (.884)	4,69 (.185)	33,41 (1.315)	33,91 (1.335)	7,31 (.288)	7,82 (.307)	29,19 (1.149)	28,45 (1.120)	23,42 (.992)	24,13 (.950)	6,86 (.270)	2,26 (.089)
F	26,26 (1.034)	4,69 (.185)	37,21 (1.465)	37,72 (1.485)	7,31 (.288)	7,82 (.307)	32,00 (1.259)	32,26 (1.270)	27,23 (1.072)	27,94 (1.100)	6,86 (.270)	2,26 (.089)
G	24,99 (.934)	4,69 (.185)	35,95 (1.415)	36,45 (1.435)	7,31 (.288)	7,82 (.307)	30,73 (1.209)	30,99 (1.220)	25,96 (1.022)	26,67 (1.050)	6,86 (.270)	2,26 (.089)
H	36,90 (1.463)	5,78 (.227)	48,05 (1.891)	48,55 (1.911)	8,42 (.331)	8,92 (.351)	43,23 (1.702)	43,49 (1.712)	38,40 (1.512)	38,65 (1.522)	7,87 (.310)	2,26 (.089)
J	45,10 (1.775)	9,25 (.364)	62,25 (2.451)	62,75 (2.470)	12,00 (.472)	12,50 (.492)	54,72 (2.154)	54,98 (2.177)	47,40 (1.866)	47,65 (1.876)	11,25 (.443)	3,70 (.146)

All dimensions in mm (inches)





## Mounting operations and hardware

For hardware dimensions consult the mounting hardware section

### Double panel mounting dimensions

Dimensions in mm (*inches*)

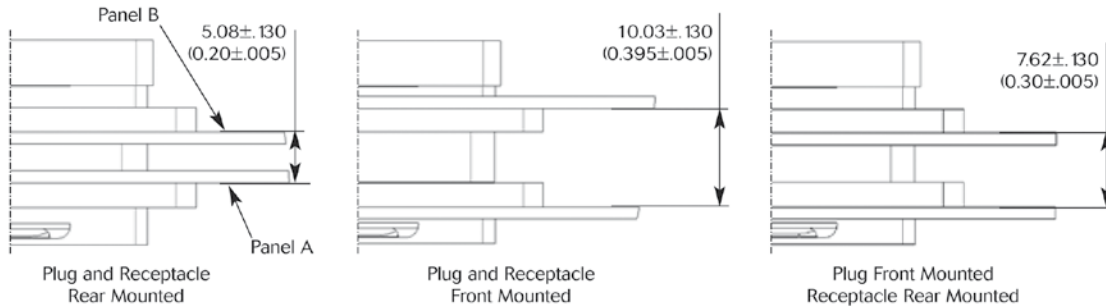

### Option 1: Front mounting on panel

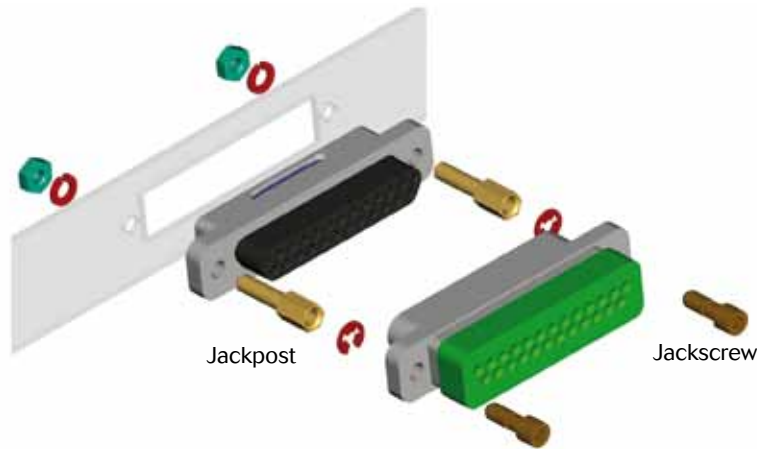

Mounting hardware for front mounting on panel:

Individual packaging (one package for one mated pair)			
Type		P/N	Description
Standard Jackpost (not for rear panel mounting)	Size A-H	8MCJP507	Jackpost Kit for <i>microComp</i> ® shell size A to H (2 jackposts + 2 washers + 2 nuts). Front panel or cable-to-cable mounting.
	Size J	8MCJP517	Jackpost Kit for <i>microComp</i> ® shell size J (2 jackposts + 2 washers + 2 nuts). Front panel or cable-to-cable mounting.

Packaging per 50 kits (one package for one mated pair)			
Type		P/N	Description
Standard Jackpost (not for rear panel mounting)	Size A-H	8MCJP50750	Jackpost Kit for <i>microComp</i> ® shell size A to H (100 jackposts + 100 washers + 100 nuts). Front panel or cable-to-cable mounting.
	Size J	8MCJP51750	Jackpost Kit for <i>microComp</i> ® shell size J (100 jackposts + 100 washers + 100 nuts). Front panel or cable-to-cable mounting.



## Mounting operations and hardware

### Option 2: Rear mounting on panel

With additional mounting on PCB: combined Option 2 and Option 3.

Mounting hardware for rear mounting on panel

for panel thickness from 0.8 mm to 3.2 mm:

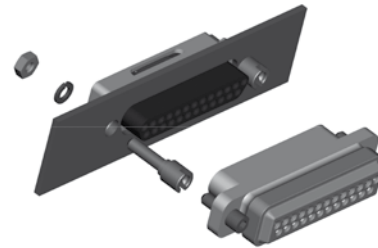

Individual packaging (one package for one mated pair)				
Type		P/N	Panel	Description
Jackpost for rear panel mounting	Size A-H	8MCJP008	0,8 mm (.031 in)	Jackpost Kit for <i>microComp</i> ® shell size A to H (2 jackposts + 2 washers + 2 nuts).
		8MCJP012	1,2 mm (.047 in)	Jackpost Kit for <i>microComp</i> ® shell size A to H (2 jackposts + 2 washers + 2 nuts).
		8MCJP016	1,6 mm (.063 in)	Jackpost Kit for <i>microComp</i> ® shell size A to H (2 jackposts + 2 washers + 2 nuts).
		8MCJP024	2,4 mm (.094 in)	Jackpost Kit for <i>microComp</i> ® shell size A to H (2 jackposts + 2 washers + 2 nuts).
		8MCJP032	3,2 mm (.126 in)	Jackpost Kit for <i>microComp</i> ® shell size A to H (2 jackposts + 2 washers + 2 nuts).
	Size J	8MCJP508	0,8 mm (.031 in)	Jackpost Kit for <i>microComp</i> ® shell size J (2 jackposts + 2 washers + 2 nuts).
		8MCJP512	1,2 mm (.047 in)	Jackpost Kit for <i>microComp</i> ® shell size J (2 jackposts + 2 washers + 2 nuts).
		8MCJP516	1,6 mm (.063 in)	Jackpost Kit for <i>microComp</i> ® shell size J (2 jackposts + 2 washers + 2 nuts).
		8MCJP524	2,4 mm (.094 in)	Jackpost Kit for <i>microComp</i> ® shell size J (2 jackposts + 2 washers + 2 nuts).
		8MCJP532	3,2 mm (.126 in)	Jackpost Kit for <i>microComp</i> ® shell size J (2 jackposts + 2 washers + 2 nuts).

Packaging per 50 kits (one package for 50 mated pairs)				
Type		P/N	Panel	Description
Jackpost for rear panel mounting	Size A-H	8MCJP00850	0,8 mm (.031 in)	Jackpost Kit for <i>microComp</i> ® shell size A to H (100 jackposts + 100 washers + 100 nuts).
		8MCJP01250	1,2 mm (.047 in)	Jackpost Kit for <i>microComp</i> ® shell size A to H (100 jackposts + 100 washers + 100 nuts).
		8MCJP01650	1,6 mm (.063 in)	Jackpost Kit for <i>microComp</i> ® shell size A to H (100 jackposts + 100 washers + 100 nuts).
		8MCJP02450	2,4 mm (.094 in)	Jackpost Kit for <i>microComp</i> ® shell size A to H (100 jackposts + 100 washers + 100 nuts).
		8MCJP03250	3,2 mm (.126 in)	Jackpost Kit for <i>microComp</i> ® shell size A to H (100 jackposts + 100 washers + 100 nuts).
	Size J	8MCJP50850	0,8 mm (.031 in)	Jackpost Kit for <i>microComp</i> ® shell size J (100 jackposts + 100 washers + 100 nuts).
		8MCJP51250	1,2 mm (.047 in)	Jackpost Kit for <i>microComp</i> ® shell size J (100 jackposts + 100 washers + 100 nuts).
		8MCJP51650	1,6 mm (.063 in)	Jackpost Kit for <i>microComp</i> ® shell size J (100 jackposts + 100 washers + 100 nuts).
		8MCJP52450	2,4 mm (.094 in)	Jackpost Kit for <i>microComp</i> ® shell size J (100 jackposts + 100 washers + 100 nuts).
		8MCJP53250	3,2 mm (.126 in)	Jackpost Kit for <i>microComp</i> ® shell size J (100 jackposts + 100 washers + 100 nuts).



## Mounting operations and hardware

### Option 3: Mounting on PCB with 90° bent contacts

Solder the connector contacts to the PCB  
Screw the connector to the PCB

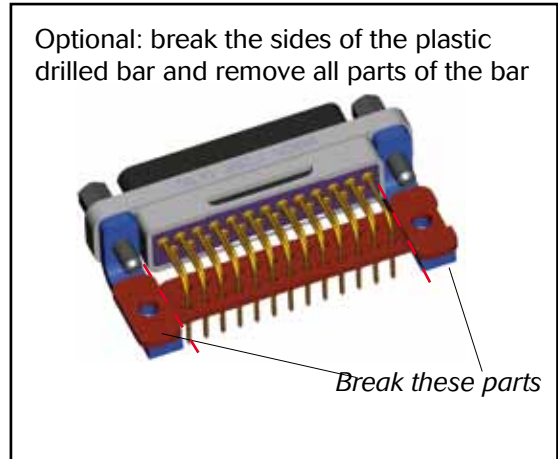
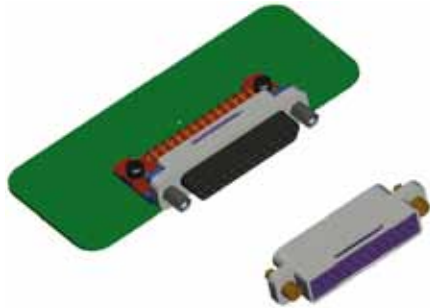

With additional rear mounting on panel: combined Option 2 and Option 3.

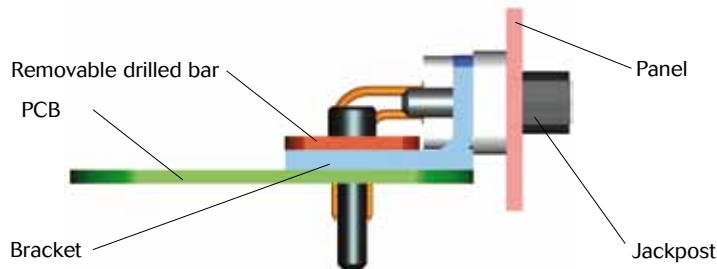

### Mounting hardware for mounting on PCB with 90° bent contacts

Individual packaging (one package for one mated pair)			
Type		P/N	Description
Standard Jackpost (not for rear panel mounting)	Size A-H	8MCJP507	Jackpost Kit for <i>microComp</i> ® shell size A to H (2 jackposts + 2 washers + 2 nuts). Front panel or cable-to-cable mounting.
	Size J	8MCJP517	Jackpost Kit for <i>microComp</i> ® shell size J (2 jackposts + 2 washers + 2 nuts). Front panel or cable-to-cable mounting.
Brackets: to fix the receptacle on the PCB	Size A-F	8MCBKAF	Bracket kit for shell size A to F (2 brackets). Not for sealed version.
	Size G-H	8MCBKGH	Bracket kit for shell size G and H (2 brackets). Not for sealed version.
	Size J	8MCBKJ	Bracket kit for shell size J (2 brackets). Not for sealed version.

Packaging per 50 kits (one package for 50 mated pairs)			
Type		P/N	Description
Standard Jackpost (not for rear panel mounting)	Size A-H	8MCJP50750	Jackpost Kit for <i>microComp</i> ® shell size A to H (100 jackposts + 100 washers + 100 nuts). Front panel or cable-to-cable mounting.
	Size J	8MCJP51750	Jackpost Kit for <i>microComp</i> ® shell size J (100 jackposts + 100 washers + 100 nuts). Front panel or cable-to-cable mounting.
Brackets: to fix the receptacle on the PCB	Size A-F	8MCBKAF50	Bracket kit for shell size A to F (100 brackets). Not for sealed version.
	Size G-H	8MCBKGH50	Bracket kit for shell size G and H (100 brackets). Not for sealed version.
	Size J	8MCBKJ50	Bracket kit for shell size J (100 brackets). Not for sealed version.



## Mounting operations and hardware

### Option 4: Mounting on PCB with straight PCB contacts

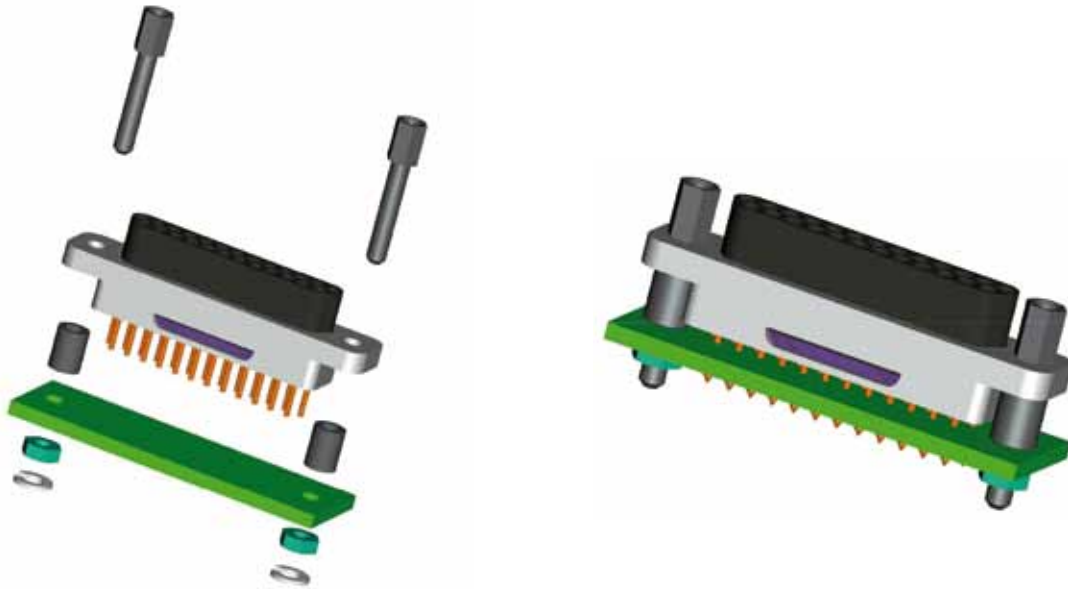

#### Mounting hardware for mounting on PCB with straight PCB contacts

Individual packaging (one package for one mated pair)			
Type		P/N	Description
Jackpost for PCB mounting (straight spills/ PC tails)	Size A-H	8MCJPS070	Jackpost kit for straight spills / PC tails <i>microComp</i> ® shell size A to H (2 jackposts + 2 spacers + 2 washers + 2 nuts). For mounting on PCB.
	Size J	8MCJPS170	Jackpost kit for straight spills / PC tails <i>microComp</i> ® shell size J (2 jackposts + 2 spacers + 2 washers + 2 nuts). For mounting on PCB.

Packaging per 50 kits (one package for 50 mated pairs)			
Type		P/N	Description
Jackpost for PCB mounting (straight spills/ PC tails)	Size A-H	8MCJPS07050	Jackpost kit for straight spills / PC tails version shell size A to H (100 jackposts + 100 washers + 100 nuts). For mounting on PCB.
	Size J	8MCJPS17050	Jackpost kit for straight spills / PC tails shell size J (100 jackposts + 100 washers + 100 nuts). For mounting on PCB.



## Mounting operations and hardware

### Panel cut-out

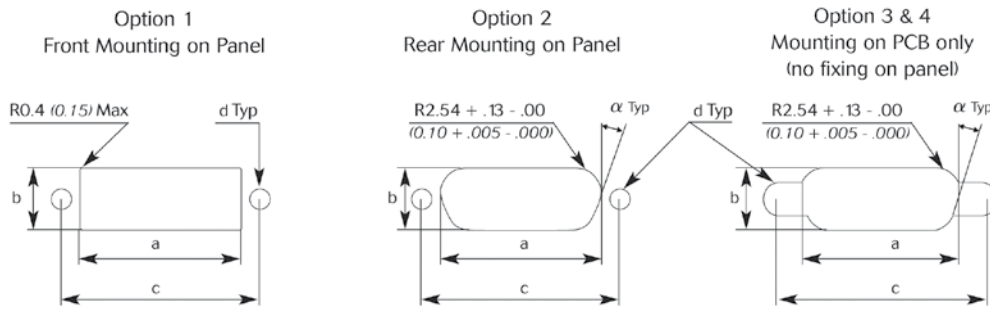

Note : Shell size A to H:  $\alpha = 27^\circ/26^\circ$  - Shell size J:  $\alpha = 0^\circ$

Shell size	Mounting option	Cut-out dimensions in mm (inch)			
		a +0.1 (+.004) -0.0 (.000)	b +0.1 (+.004) -0.0 (.000)	c +0.1 (+.004) -0.1 (-.004)	d +0.1 (+.004) -0.0 (.000)
A	1	10.36 (.408)	6.88 (.270)	14.35 (.565)	2.26 (.089)
	2	10.19 (.401)	6.40 (.252)	14.35 (.565)	2.26 (.089)
	3 & 4	10.19 (.401)	6.40 (.252)	14.35 (.565)	3.70 (.146)
B	1	14.17 (.558)	6.88 (.270)	18.56 (.731)	2.26 (.089)
	2	14.00 (.551)	6.40 (.252)	18.56 (.731)	2.26 (.089)
	3 & 4	14.00 (.551)	6.40 (.252)	18.56 (.731)	3.70 (.146)
C	1	17.98 (.708)	6.88 (.270)	21.97 (.865)	2.26 (.089)
	2	17.81 (.701)	6.40 (.252)	21.97 (.865)	2.26 (.089)
	3 & 4	17.81 (.701)	6.40 (.252)	21.97 (.865)	3.70 (.146)
D	1	20.52 (.808)	6.88 (.270)	24.51 (.965)	2.26 (.089)
	2	20.34 (.801)	6.40 (.252)	24.51 (.965)	2.26 (.089)
	3 & 4	20.34 (.801)	6.40 (.252)	24.51 (.965)	3.70 (.146)
E	1	24.33 (.958)	6.88 (.270)	28.32 (1.115)	2.26 (.089)
	2	24.16 (.951)	6.40 (.252)	28.32 (1.115)	2.26 (.089)
	3 & 4	24.16 (.951)	6.40 (.252)	28.32 (1.115)	3.70 (.146)
F	1	28.14 (1.108)	6.88 (.270)	32.13 (1.265)	2.26 (.089)
	2	27.97 (1.101)	6.40 (.252)	32.13 (1.265)	2.26 (.089)
	3 & 4	27.97 (1.101)	6.40 (.252)	32.13 (1.265)	3.70 (.146)
G	1	26.87 (1.058)	8.00 (.315)	30.86 (1.215)	2.26 (.089)
	2	26.70 (1.051)	7.49 (.295)	30.86 (1.215)	2.26 (.089)
	3 & 4	26.70 (1.051)	7.49 (.295)	30.86 (1.215)	3.70 (.146)
H	1	39.05 (1.537)	8.00 (.315)	43.36 (1.707)	2.26 (.089)
	2	38.65 (1.522)	7.49 (.295)	43.36 (1.707)	2.26 (.089)
	3 & 4	38.65 (1.522)	7.49 (.295)	43.36 (1.707)	3.70 (.146)
J	1	48.05 (1.892)	11.40 (.449)	54.85 (2.159)	3.20 (.126)
	2	46.80 (1.842)	11.10 (.437)	54.85 (2.159)	3.20 (.126)
	3 & 4	46.80 (1.842)	11.10 (.437)	54.85 (2.159)	5.60 (.220)

All dimensions in mm (inches)



## Mounting operations and hardware

### PCB drilling

Shell size	Number of contacts	Drilling dimensions
A	7	
B	11	
C	13	
D	17	
E	21	

Shell size	Number of contacts	Drilling dimensions
F	25	
G	33	
H	51	
J	104	

All dimensions in mm (inches)

	X	Y
OL3	1.732 (.068)	3.464 (.136)
1AON	2.540 (.1)	5.08 (.2)

Note: we suggest 0.89 (.035) Ø hole for contact termination positions on PCB (0.50 (.020) Ø spills).



## Mounting hardware

### Brackets for mounting on PCB with 90° bent contacts

Use thread locking (Loctite 222) to screw standard jackpost in the brackets. Torque value: 0,44Nm to 0,48Nm

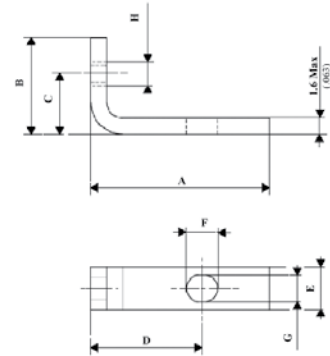

Shell size	A to H		J	
Torque value	Min (Nm)	Max (Nm)	Min (Nm)	Max (Nm)
	0.44	0.48	0.6	0.66

For shell size	P/N for individual packaging (one package for one mated pair: 2 brackets)	P/N for packaging per 50 (one package for 50 mated pair: 100 brackets)	A max	B max	C	D	E	F max	G	H
A to F	8MCBKAF	8MCBKAF50	14.10 (.555)	8.60 (.338)	5.0±0.10 (.197±.004)	9.17 ±0.10 (.361 ±.004)	4.0 ±0.10 (.158 ±.004)	3.15 (.124)	2.44 ±0.10 (.096 ±.004)	#20-56 UNC-2B
G and H	8MCBKGH	8MCBKGH50	16.90 (.665)	9.10 (.359)	5.6±0.10 (.220 ±.004)	10.44±0.10 (.411 ±.004)	4.0±0.10 (.158 ±.004)	3.15 (.124)	2.44 ±0.10 (.096 ±.004)	#20-56 UNC-2B
J	8MCBKJ	8MCBKJ50	23.10 (.909)	13.10 (.515)	7.35±0.10 (.290 ±.004)	13.13±0.10 (.516 ±.004)	6.50±0.10 (.256 ±.004)	4.20 (.165)	3.15 ±0.15 (.124 ±.006)	#20-56 UNC-2B

All dimensions in mm (inches)

### Standard Jackpost

Shell size	A to H		J	
Torque Values	Min (Nm)	Max (Nm)	Min (Nm)	Max (Nm)
Jackpost male side	0.44	0.48	0.6	0.66
Jackpost female side	0.28	0.32	0.4	0.44
Nut	0.44	0.48	0.6	0.66

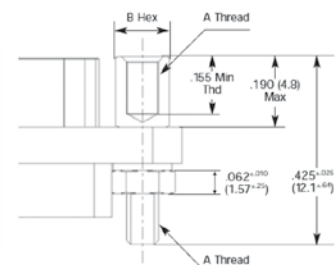
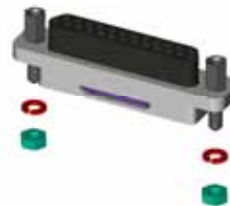

For shell size	A to H	J
MIL Spec	MIL 83513/05-07	MIL 83513/05-17
A thread size	#2-56 UNC	#4-40 UNC
B hex size in mm (inch)	3,18 (.125)	4,75 (.187)
Lock washer	NASM35338-134	NASM35338-135
Material & Finish	303 stainless steel, passivated per QQ-P-35	
P/N for Individual packaging (one package for one mated pair: 2 posts, 2 washers and 2 nuts)	8MCJP507	8MCJP517
P/N for packaging per 50 kits (one package for 50 mated pair: 100 posts, 100 washers and 100 nuts)	8MCJP50750	8MCJP51750



## Mounting hardware

### Jackposts for rear panel mounting

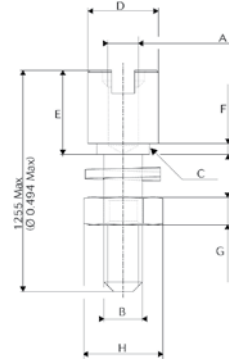
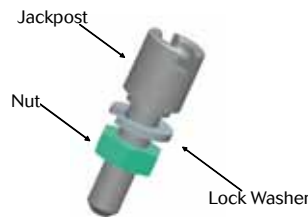
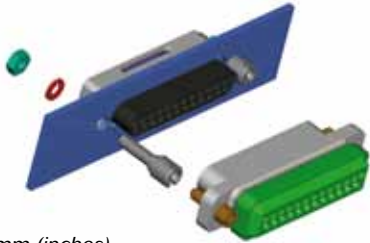

All dimensions in mm (inches)

For shell size A to H					
Panel thickness	0,8 mm (.031 in)	1,2 mm (.047 in)	1,6 mm (.063 in)	2,4 mm (.094 in)	3,2 mm (.126 in)
A thread size	#2-56 UNC-2B				
B thread size	#2-56 UNC-2A				
C max	Ø 3,0 (.118)				
D max	Ø 4,1 (.161)				
E	4,70/4,83 (.185/.190)				
F max	0,615 (.020)	1,09 (.042)	1,45 (.057)	2,23 (.087)	3,05 (.120)
G max	1.67 (.066)				
H max	4,0 (.157)				
Lock washer	NASM35338-134				
Material & Finish	303 stainless steel, passivated per QQ-P-35				
P/N for Individual packaging (one package for one mated pair: 2 posts, 2 washers and 2 nuts)	8MCJP008	8MCJP012	8MCJP016	8MCJP024	8MCJP032
P/N for packaging per 50 kits (one package for 50 mated pair: 100 posts, 100 washers and 100 nuts)	8MCJP00850	8MCJP01250	8MCJP01650	8MCJP02450	8MCJP03250

For shell size J					
Panel thickness	0,8 mm (.031 in)	1,2 mm (.047 in)	1,6 mm (.063 in)	2,4 mm (.094 in)	3,2 mm (.126 in)
A thread size	#4-40 UNC-2B				
B thread size	#4-40 UNC-2A				
C max	Ø 3,6 (.141)				
D max	Ø 4,71 (.185)				
E	4,45/4,70 (.175/.185)				
F max	0,615 (.020)	1,09 (.042)	1,45 (.057)	2,23 (.087)	3,05 (.120)
G max	1.67 (.066)				
H max	4,0 (.157)				
Lock washer	NASM35338-135				
Material & Finish	303 stainless steel, passivated per QQ-P-35				
P/N for Individual packaging (one package for one mated pair: 2 posts, 2 washers and 2 nuts)	8MCJP008	8MCJP512	8MCJP516	8MCJP524	8MCJP532
P/N for packaging per 50 kits (one package for 50 mated pair: 100 posts, 100 washers and 100 nuts)	8MCJP50850	8MCJP51250	8MCJP51650	8MCJP52450	8MCJP53250



## Mounting hardware

Jackposts for PCB mounting (straight spills/PC tails):

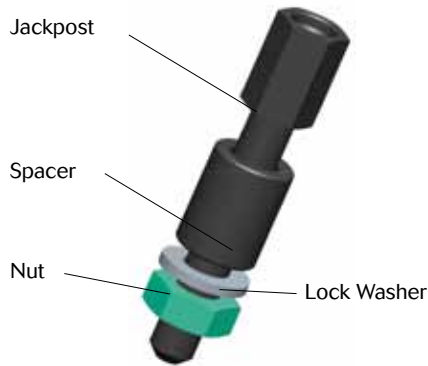

For shell size	A to H	J
A thread size	#2-56 UNC	#4-40 UNC
B hex size in mm (inch)	3,18 (.125)	4,75 (.187)
Lock washer	NASM35338-134	NASM35338-135
Material & Finish	303 stainless steel, passivated per QQ-P-35	
P/N for Individual packaging (one package for one mated pair: 2 posts, 2 washers and 2 nuts)	8MCJPS070	8MCJPS170
P/N for packaging per 50 kits (one package for 50 mated pair: 100 posts, 100 washers and 100 nuts)	8MCJPS07050	8MCJPS17050
Jackpost		
Spacer		



## Mounting hardware

### Standard Jackscrews

Torque Values	Min (Nm)	Max (Nm)
Screw	0.40	0.44

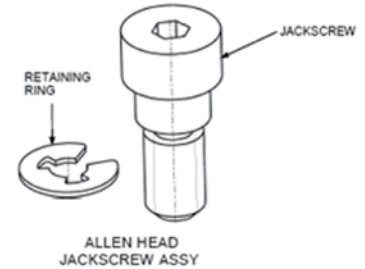
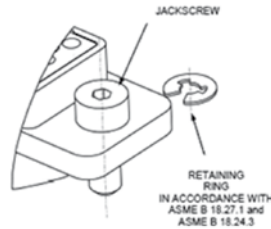

For shell size	A to H		J	
	#2-56 UNC		#4-40 UNC	
Dimensions in mm (inch)				
Head type	Allen head	Slot head	Allen head	Slot head
MIL Spec	MIL 83513/05-02	MIL 83513/05-05	MIL 83513/05-12	MIL 83513/05-15
Material & Finish	303 stainless steel, passivated per QQ-P-35			
P/N for Individual packaging (one package for one mated pair: 2 screws and 2 e-rings)	8MCJS502	8MCJS505	8MCJS512	8MCJS515
P/N for packaging per 50 kits (one package for 50 mated pair: 100 screws and 100 e-rings)	8MCJS50250	8MCJS50550	8MCJS51250	8MCJS51550



## Hermetic Feedthrough



microComp® feedthroughs have a leak rate less than  $10^{-9}$  atm.  $\text{cm}^3/\text{s}$  thanks to a ceramic sealing technology developed by PA&E, a SOURIAU subsidiary.

Both sides of the feedthrough are male contacts which are fully protected by the insulator to avoid any bent pin.

Shell types: O'ring or laser weldable (consult us).



### Technical characteristics

#### Electrical

- Contact size: #26
- Current rating: 2,5 Amp
- Insulation resistance:  
Greater than 500 Megohms at  $500 \pm 10\%$  VDC at  $25^\circ\text{C}$  when tested IAW MIL-STD-1344, method 3003.
- Dielectric withstanding voltage:  
Must Show no evidence of breakdown or flashover when subjected to 500 VAC RMS 60 Hz  
IAW MIL-STD-1344, method 3001  
Duration of application to be 1 Sec. Min.

#### Mechanical

- Endurance / durability:  
500 mating/unmating operations
- Vibration:  
random: 44g  
sine: 20g
- Shock: 50g

#### Climatic

- Operating temperature range:  
 $-55^\circ\text{C} / +170^\circ\text{C}$

#### Environmental

- RoHS: compliant

#### Material and finishes

- Shell:  
Stainless steel (dismountable version) or aluminum (laser weldable version).
- Contacts:  
Beryllium-copper
- Hermetic insulator:  
Ceramic sealing
- Contact insulator: thermoplastic
- Contact plating:  
Electrolytic nickel plate IAW-QQ-N-290 - .000100/.000250 thick.  
Gold plate IAW ASTM B488, Type III, code A - .000050/.000100 thick.



Physical dimensions

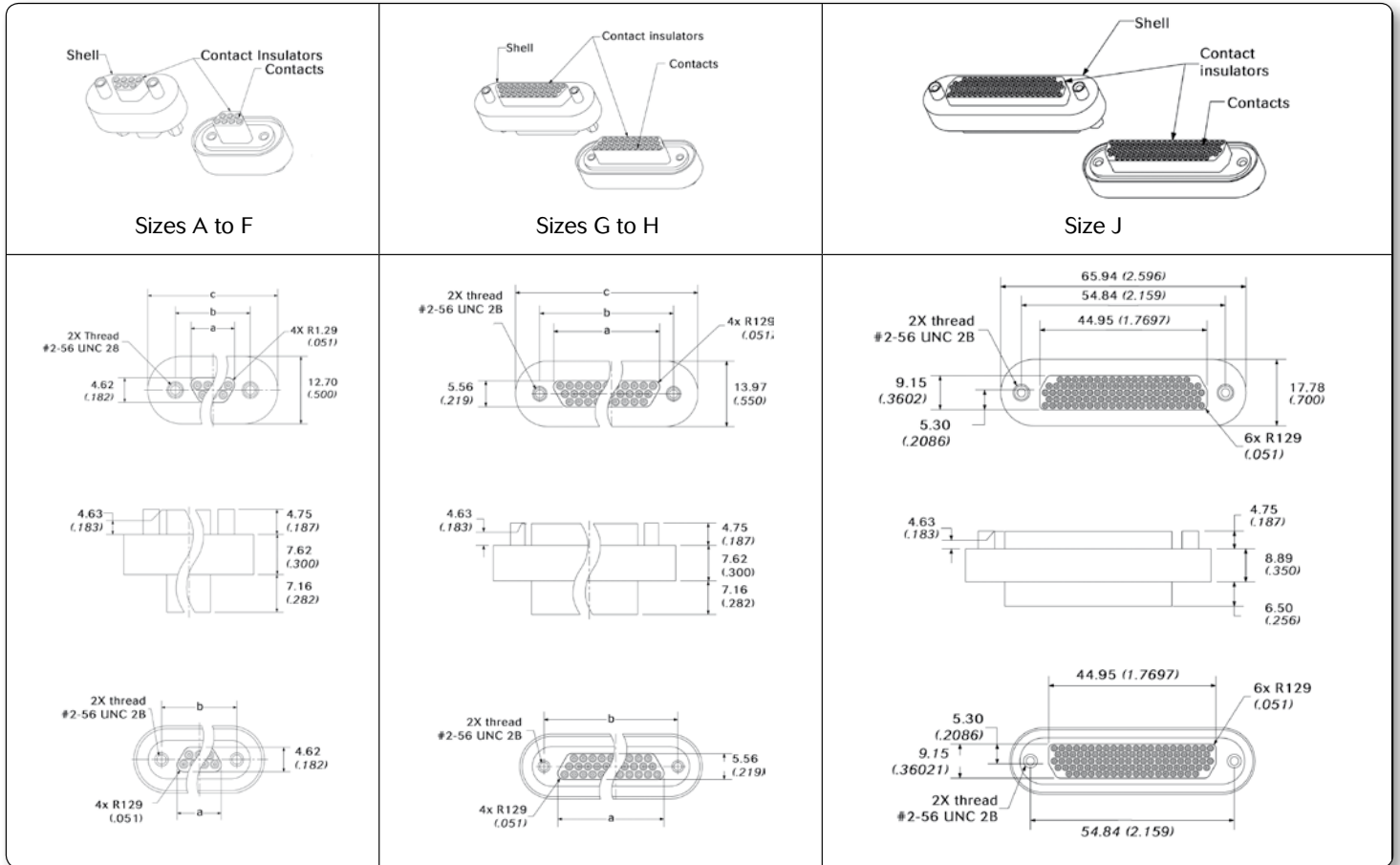

Shell size	a	b	c	d
A	8,41 (.331)	14,35 (.565)	21,46 (.845)	10,19 (.401)
B	12,22 (.481)	18,16 (.715)	25,27 (.995)	14,00 (.551)
C	16,03 (.631)	22,00 (.866)	29,08 (1.145)	17,81 (.701)
D	18,57 (.731)	24,51 (.965)	31,62 (1.245)	20,35 (.801)
E	22,38 (.881)	28,32 (1.115)	35,43 (1.395)	24,16 (.951)
F	26,19 (1.031)	32,13 (1.265)	39,24 (1.545)	27,97 (1.101)
G	24,92 (.981)	30,86 (1.215)	41,33 (1.627)	38,66 (1.522)
H	36,78 (1.448)	42,85 (1.687)	53,82 (2.119)	38,66 (1.522)

All dimensions in mm (inches)



## Hermetic Feedthrough

### Panel cutout

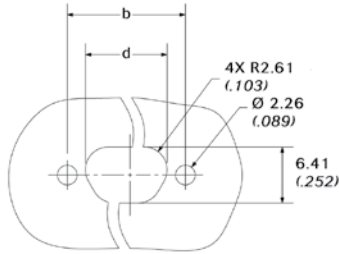

Sizes A to F

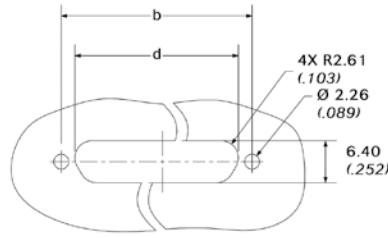

Sizes G to H

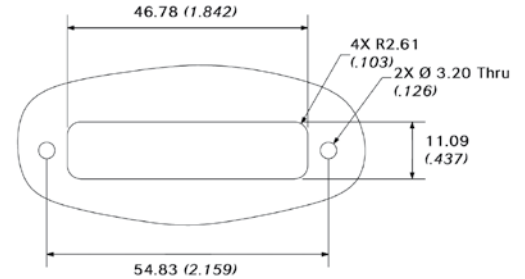

Size J

Use the jackposts for panel mounting defined in the Mounting Hardware section to mount the connector to the panel.

### Ordering information

Hermetic series	8MCH	BD	S	N	F25	PP
<b>Bulkhead Feedthrough:</b>		BD: Dismountable version (with O'ring) BL: laser weldable version				
<b>Shell Material:</b>		A: Aluminum (laser weldable version only)* S: Stainless Steel (dismountable version only)				
<b>Shell plating:</b>		N: Nickel				
<b>Shell size &amp; contact layout:</b>		A7: 7 contacts B11: 11 contacts* C13: 13 contacts* D17: 17 contacts E21: 21 contacts* F25: 25 contacts G33: 33 contacts* H51: 51 contacts J104: 104 contacts				
<b>Contact type:</b>		PP: Male/male bulkhead				

Jackpost kits are never included  
\* Consult us for availability

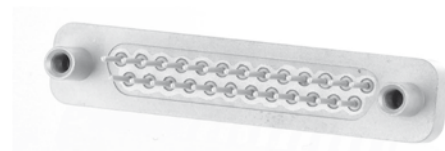

For Laser weldable version or other hermetic *microComp*® with PC tails (straight or 90° bent): consult us



## EMI Backshells

### Technical features

- Backshell kits consist of one low profile machined aluminum alloy backshell nickel plated, two jackscrews (or jackposts) and two clips.
- Cable exits are designed for banded clamp termination. Once the braided copper shield is secure to the backshell the cable can be terminated with an heatshrink boot.
- Available with circular and/or elliptical entry, depending on shell size.
- Available with straight, 45° and 90° entry.
- For cable-to-box or cable-to-cable connection (for one cable-to-cable assembly, order one backshell with jackpost and one with jackscrew).
- These backshells are non environmental and are not for use with *microComp*® equipped with grommets. Fill with potting compound to prevent water intrusion.

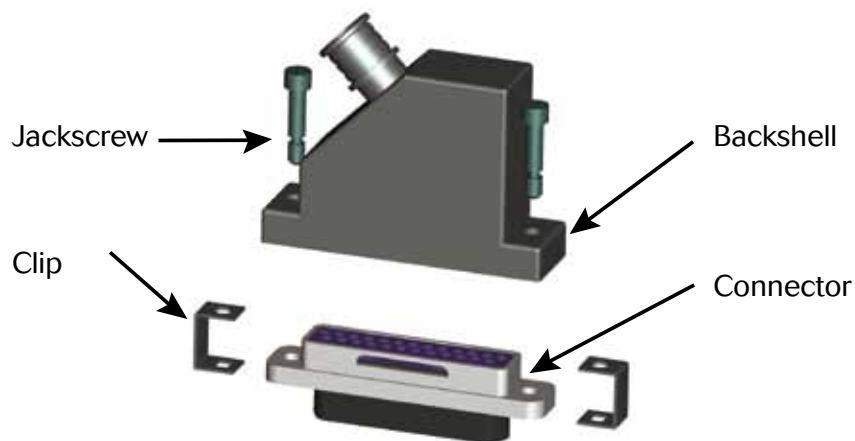

### Cable entry size

Each backshell is available with 2 entry sizes, circular and/or elliptical

Shell size	Entry code	Entry shape	Circular entry size in mm ( <i>inch</i> )		Elliptical entry size in mm ( <i>inch</i> )		Entry surface in mm <sup>2</sup> ( <i>inch</i> <sup>2</sup> )
			ø g	x ±0.15 (±.060)	y ±0.15(±.060)		
A-B	02	Circular	3,20 (.126)	-	-	8.04 (.012)	
	03	Circular	4,80 (.189)	-	-	18.1 (.028)	
C-D	03	Circular	4,80 (.189)	-	-	18.1 (.028)	
	04	Circular	6,40 (.252)	-	-	32.17 (.05)	
E-F	03	Circular	4,80 (.189)	-	-	18.1 (.028)	
	05	Elliptical	-	10,80 (.425)	5,80 (.229)	49.2 (.076)	
G	04	Circular	6,40 (.252)	-	-	32.17 (.05)	
	06	Circular	9,50 (.374)	-	-	70.9 (.110)	
H	05	Elliptical	-	10,80 (.425)	5,80 (.229)	49.2 (.076)	
	07	Elliptical	-	21,00 (.827)	5,8 (.228)	95.7 (.148)	
J	08	Elliptical	-	23,50 (.925)	6,80 (.268)	125.5 (.195)	
	10	Elliptical	-	33,00 (1.3)	7,8 (.307)	202.15 (.313)	



## EMI Backshells

### Straight backshell

<b>Straight backshell</b>	<b>8MCBS</b>	<b>F</b>	<b>001</b>	<b>03</b>	<b>N</b>
Shell size:	<b>A - B - C - D - E - F - G - H - J</b>				
Environment:	<b>None:</b> for connector without grommet				
Straight version:	001				
Cable entry type:	see «Cable entry size» table				
Finish:	<b>N:</b> electroless Nickel				
Mounting hardware:	<b>None:</b> jackscrews (standard use) <b>F:</b> jackposts (for cable to cable connection only)				

Backshells are always supplied with 2 clips and 2 jackscrews or jackposts

*Circular entry*

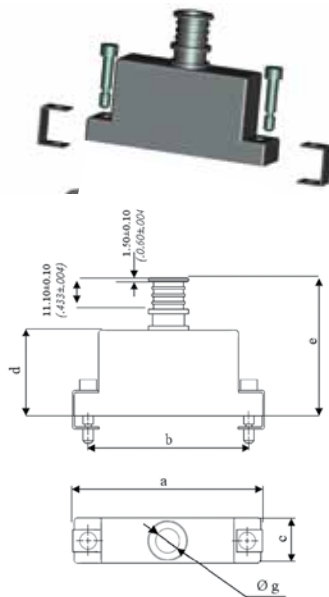

*Elliptical entry*

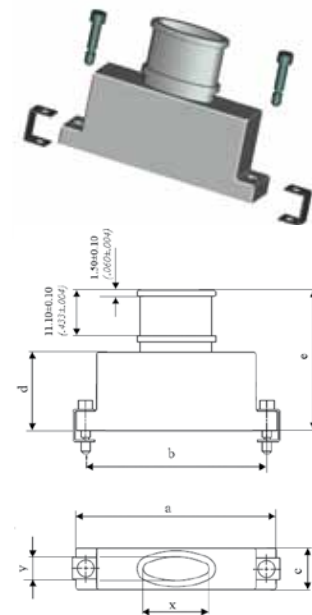

Shell Size	A	B	C	D	E	F	G	H	J
a ±0.15 (±060)	19,70 (.776)	23,40 (.921)	27,30 (1.075)	29,85 (1.176)	33,70 (1.327)	37,50 (1.476)	36,10 (1.421)	48,85 (1.923)	62,80 (2.473)
b ±0.13 (±051)	14,35 (.565)	18,16 (.715)	21,97 (.865)	24,51 (.965)	28,32 (1.115)	32,13 (1.265)	30,86 (1.215)	43,36 (1.707)	54,85 (2.160)
c ±0.15 (±060)	9,00 (.354)	9,00 (.354)	9,00 (.354)	9,00 (.354)	9,00 (.354)	9,00 (.354)	10,00 (.394)	10,00 (.395)	13,00 (.512)
d Max.	10,00 (.394)	12,00 (.472)	14,00 (.551)	16,00 (.623)	17,00 (.670)	18,00 (.709)	19,00 (.748)	19,00 (.748)	21,00 (.827)
e Max.									

Max weight in g (oz)	3,50 (0.12)	3,80 (0.13)	5,00 (0.18)	5,60 (0.20)	7,00 (0.25)	7,70 (0.27)	9,20 (0.32)	9,50 (0.34)	14,50 (0.51)
-------------------------	----------------	----------------	----------------	----------------	----------------	----------------	----------------	----------------	-----------------

All dimensions in mm (inches)



## EMI Backshells

### 45° backshell

<b>Straight backshell</b>	<b>8MCBS</b>	<b>F</b>	<b>101</b>	<b>03</b>	<b>N</b>
Shell size:	<b>A - B - C - D - E - F - G - H - J</b>				
Environment:	<b>None:</b> for connector without grommet				
Straight version:	101				
Cable entry type:	see «Cable entry size» table				
Finish:	<b>N:</b> electroless Nickel				
Mounting hardware:	<b>None:</b> jackscrews (standard use) <b>F:</b> jackposts (for cable to cable connection only)				

Backshells are always supplied with 2 clips and 2 jackscrews or jackposts

*Circular entry*

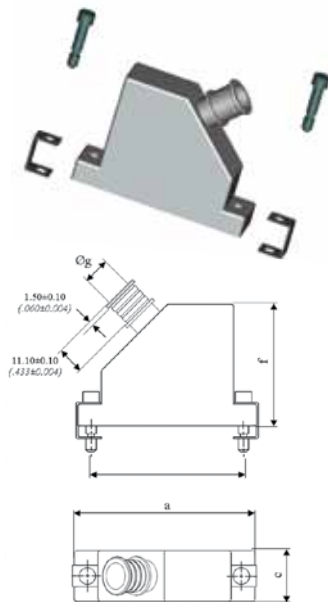

*Elliptical entry*

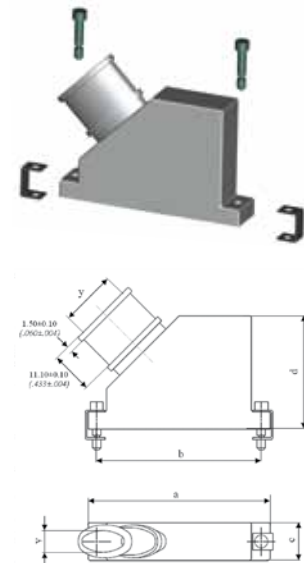

Shell Size	A	B	C	D	E	F	G	H	J
a ±0.15 (±060)	19,70 (.776)	23,40 (.921)	27,30 (1.075)	29,85 (1.176)	33,70 (1.327)	37,50 (1.476)	36,10 (1.421)	48,85 (1.923)	62,80 (2.473)
b ±0.13 (±051)	14,35 (.565)	18,16 (.715)	21,97 (.865)	24,51 (.965)	28,32 (1.115)	32,13 (1.265)	30,86 (1.215)	43,36 (1.707)	54,85 (2.160)
c ±0.15 (±060)	9,00 (.354)	9,00 (.354)	9,00 (.354)	9,00 (.354)	9,00 (.354)	9,00 (.354)	10,00 (.394)	10,00 (.395)	13,00 (.512)
d Max.	10,00 (.394)	12,00 (.472)	14,00 (.551)	16,00 (.623)	17,00 (.670)	18,00 (.709)	19,00 (.748)	23,00 (.905)	25,00 (.984)
f Max.	21,00 (.827)	23,00 (.906)	25,00 (.984)	27,00 (1.063)	28,00 (1.102)	29,00 (1.142)	30,00 (1.181)	30,00 (1.058)	38,00 (1.340)

Max weight in g (oz)	5,20 (0.18)	6,20 (0.22)	7,35 (0.26)	8,45 (0.30)	9,25 (0.33)	10,70 (0.38)	11,45 (0.40)	12,00 (0.42)	19,00 (0.67)
-------------------------	----------------	----------------	----------------	----------------	----------------	-----------------	-----------------	-----------------	-----------------

All dimensions in mm (inches)



## EMI Backshells

### 90° backshell

<b>Straight backshell</b>	<b>8MCBS</b>	<b>F</b>	<b>201</b>	<b>03</b>	<b>N</b>
Shell size:	<b>A - B - C - D - E - F - G - H - J</b>				
Environment:	<b>None:</b> for connector without grommet				
Straight version:	201				
Cable entry type:	see «Cable entry size» table				
Finish:	<b>N:</b> electroless Nickel				
Mounting hardware:	<b>None:</b> jackscrews (standard use) <b>F:</b> jackposts (for cable to cable connection only)				

Backshells are always supplied with 2 clips and 2 jackscrews or jackposts

*Circular entry*

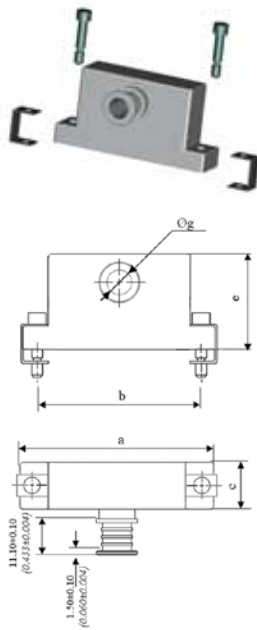

*Elliptical entry*

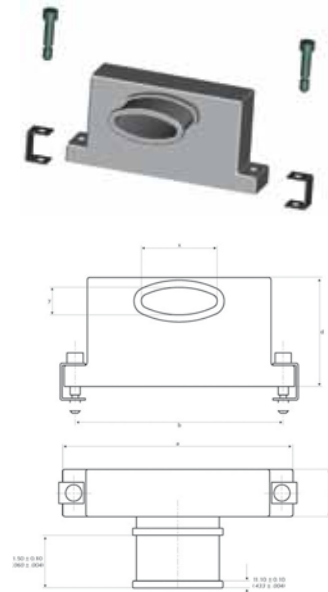

Shell Size	A	B	C	D	E	F	G	H	J
a ±0.15 (±0.060)	19,70 (.776)	23,40 (.921)	27,30 (1.075)	29,85 (1.176)	33,70 (1.327)	37,50 (1.476)	36,10 (1.421)	48,85 (1.923)	62,80 (2.473)
b ±0.13 (±0.051)	14,35 (.565)	18,16 (.715)	21,97 (.865)	24,51 (.965)	28,32 (1.115)	32,13 (1.265)	30,86 (1.215)	43,36 (1.707)	54,85 (2.160)
c ±0.15 (±0.060)	9,00 (.354)	9,00 (.354)	9,00 (.354)	9,00 (.354)	9,00 (.354)	9,00 (.354)	10,00 (.394)	10,00 (.395)	13,00 (.512)
d Max.	10,00 (.394)	12,00 (.472)	14,00 (.551)	16,00 (.623)	17,00 (.670)	18,00 (.709)	19,00 (.748)	23,00 (.905)	25,00 (.984)

Max weight in g (oz)	5,13 (0.18)	6,20 (0.22)	7,31 (0.26)	8,44 (0.30)	9,25 (0.33)	10,44 (0.38)	11,44 (0.40)	12,00 (0.42)	19,00 (0.67)
-------------------------	----------------	----------------	----------------	----------------	----------------	-----------------	-----------------	-----------------	-----------------

All dimensions in mm (inches)



## Dust Caps

### Molded plastic dust caps

- Anti-static dust caps in rugged plastic material that resists cracking
- Material : Polypropylene
- Color : black.

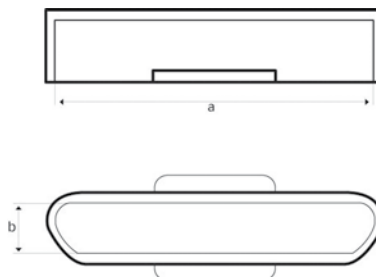

Shell size	Gender	Part number	a	b
A	P (male)	8MC DC AP	8 (.315)	4,7 (.184)
	S (female)	8MC DC AS	9,8 (.385)	6,4 (.250)
B	P	8MC DC BP	11,8 (.465)	4,7 (.184)
	S	8MC DC BS	13,6 (.535)	6,4 (.250)
C	P	8MC DC CP	15,6 (.615)	4,7 (.184)
	S	8MC DC CS	17,4 (.685)	6,4 (.250)
D	P	8MC DC DP	18,2 (.715)	4,7 (.184)
	S	8MC DC DS	19,9 (.785)	6,4 (.250)
E	P	8MC DC EP	22 (.865)	4,7 (.184)
	S	8MC DC ES	23,7 (.935)	6,4 (.250)
F	P	8MC DC FP	25,8 (1.015)	4,7 (.184)
	S	8MC DC FS	27,6 (1.085)	6,4 (.250)
G	P	8MC DC GP	24,5 (.965)	5,8 (.227)
	S	8MC DC GS	26,3 (1.035)	7,4 (.292)
H	P	8MC DC HP	37,9 (1.492)	5,8 (.228)
	S	8MC DC HS	38,8 (1.528)	7,4 (.291)
J	P	8MC DC JP	45,2 (1.78)	9,35 (.368)
	S	8MC DC JS	46,8 (1.843)	11 (.433)

All dimensions in mm (inches)



**Under development - Consult us**

**Quick connect for harsh environment - 104 contacts**



**Quick connect for cabin environment**



**Fully IP67 *microComp*<sup>®</sup>**

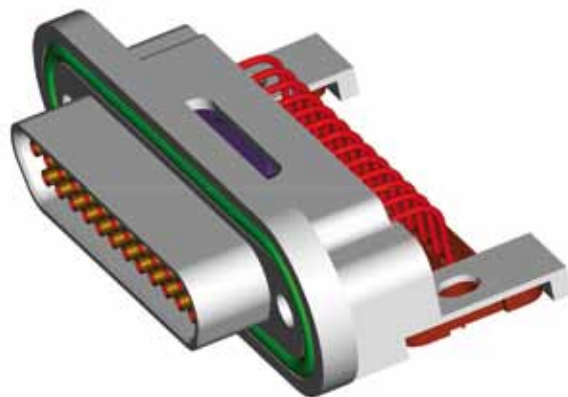



# Reliable People, Reliable Solutions

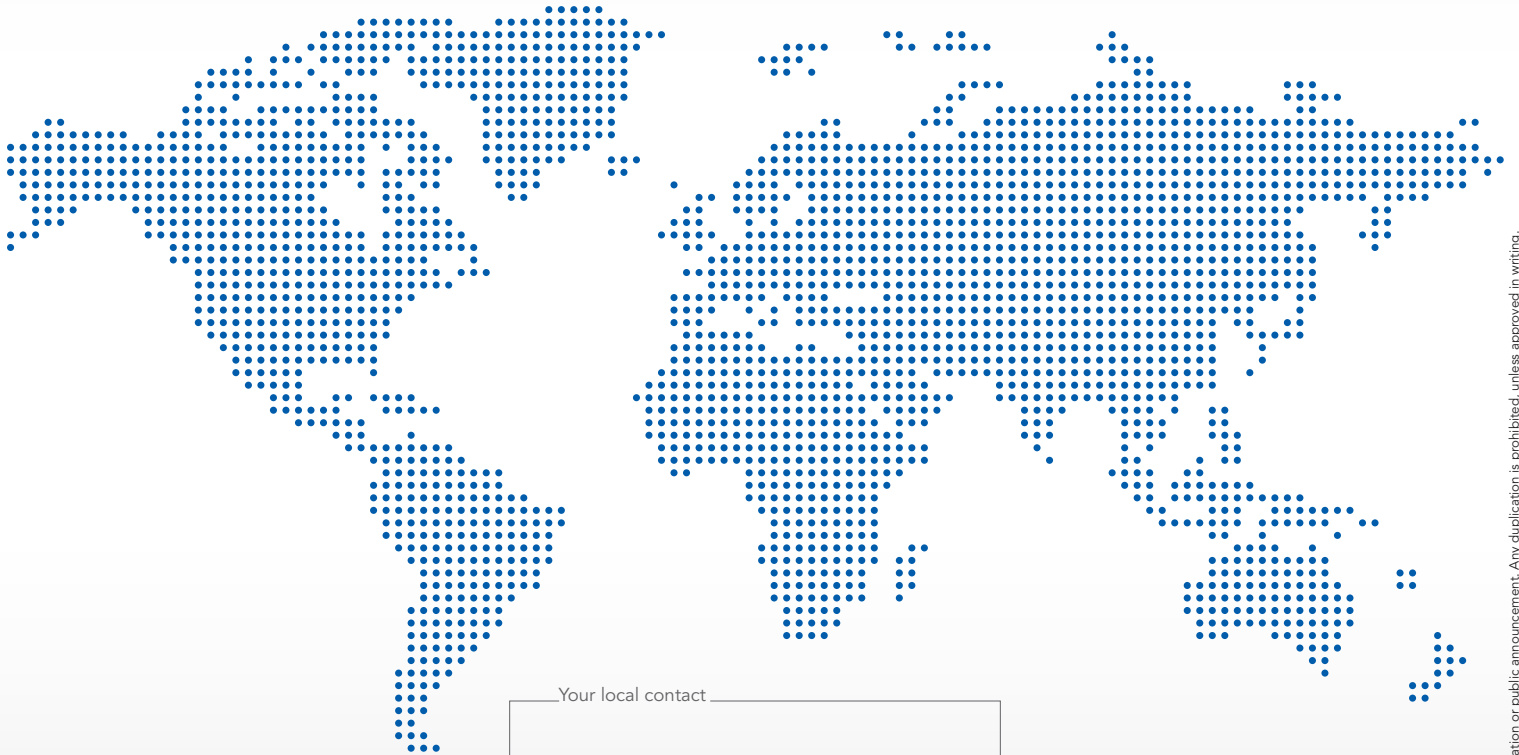

Your local contact



Our contribution to environmental protection:  
This catalog is printed on PEFC certified paper  
Advancement of sustainable wood cultivation. [www.pefc.org](http://www.pefc.org)

[www.esterline-connection-technologies.com](http://www.esterline-connection-technologies.com)  
[technical-emear-ect@esterline.com](mailto:technical-emear-ect@esterline.com) (Europe - Asia - Africa)  
[technical-americas-ect@esterline.com](mailto:technical-americas-ect@esterline.com) (North America)



## SOURIAU