

FEATURES

- 1、Low profile construction and miniature size
- 2、Magnetic shielded construction .
- 3、High current saturation.
- 4、For new generation portable product D/D converter unit.

APPLICATIONS

DVD、Set-Top Box、DSC PDA、LCD display Cellular phones, HDD, etc.

PRODUCT IDENTIFICATION

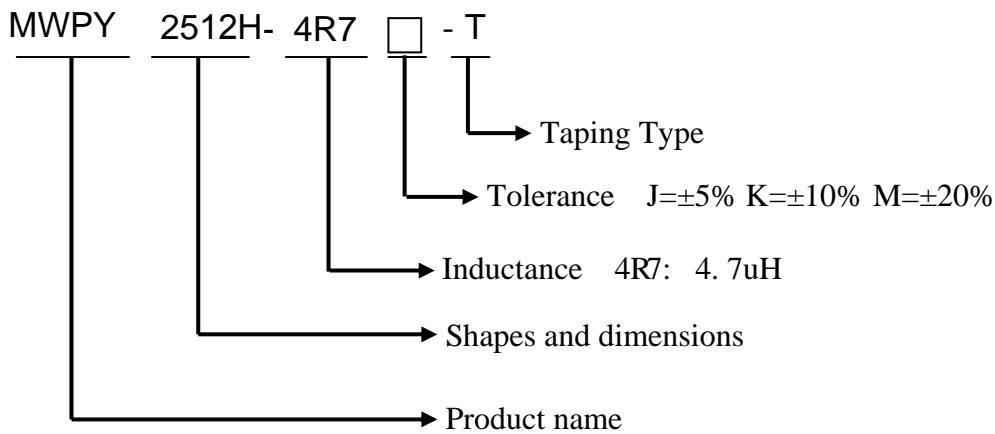

SHAPES AND DIMENSIONS(Unit:mm)

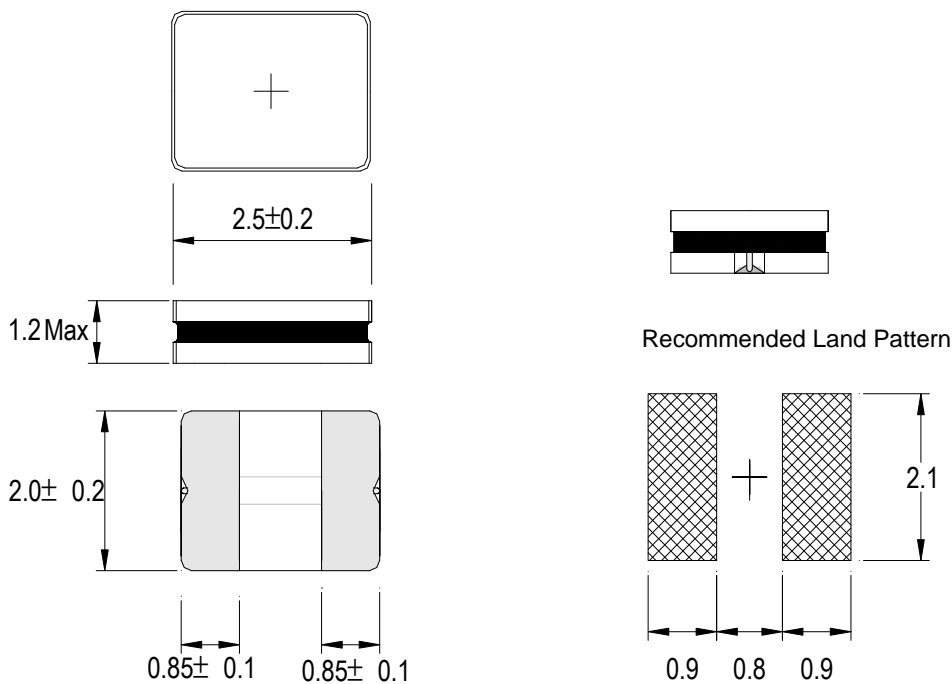

ELECTRICAL CHARACTERISTICS

PART NUMBER	INDUCTANCE (μ H)	RDC ($m\Omega$)		Isat (A)		Irms (A)		TOLERANCE
		Typ.	Max	Typ.	Max	Typ.	Max	
MWPY2512H-R47M-T	0.47	41	48	3.70	3.50	2.30	2.10	N : 30 % M : 20 %
MWPY2512H-R68M-T	0.68	51	59	3.20	3.00	2.05	1.85	
MWPY2512H-1R0M-T	1.0	72	87	2.90	2.75	1.70	1.60	
MWPY2512H-1R5M-T	1.5	91	110	2.25	2.10	1.50	1.40	
MWPY2512H-2R2M-T	2.2	105	125	1.70	1.50	1.40	1.35	
MWPY2512H-3R3M-T	3.3	228	278	1.40	1.25	1.00	0.90	
MWPY2512H-4R7M-T	4.7	244	298	1.10	0.95	0.93	0.83	
MWPY2512H-100M-T	10.0	645	778	0.84	0.73	0.55	0.51	

1. Test Frequency : 1MHz / 0.1 V
2. Test equipment :
L/Q : HP-4286A
SRF : HP-4291B , HP4287A
RDC: HP-4286A , CH16502
3. Isat : Based on Inductance decrease 30%
4. Irms : Based on Temperature increase 40°C
5. Operating temperature range: -40 to +125°C (Including self-temperature rise)
6. Storage Temp.: -40°C TO+85°C

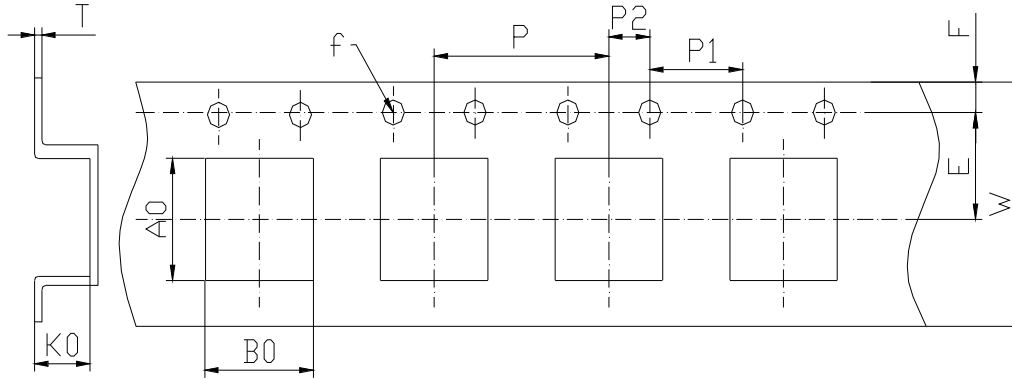
PACKAGING AND DIMENSIONS

SIZE	A0	B0	E	F	f	P	P1	P2	W	T	K0
MWPY2010	2.65	2.65	5.50	1.75	1.50	4.00	4.00	2.00	8.00	0.25	1.25
MWPY2510	2.73	2.23	5.50	1.75	1.50	4.00	4.00	2.00	8.00	0.25	1.30
MWPY2512	2.73	2.23	5.50	1.75	1.50	4.00	4.00	2.00	8.00	0.25	1.50
MWPY3010	3.25	3.25	5.50	1.75	1.50	4.00	4.00	2.00	8.00	0.25	1.25
MWPY3012	3.25	3.25	5.50	1.75	1.50	4.00	4.00	2.00	8.00	0.25	1.45
MWPY3015	3.25	3.25	5.50	1.75	1.50	4.00	4.00	2.00	8.00	0.25	1.75
MWPY4010	4.30	4.30	5.50	1.75	1.50	8.00	4.00	2.00	12.00	0.25	1.25
MWPY4012	4.30	4.30	5.50	1.75	1.50	8.00	4.00	2.00	12.00	0.25	1.45
MWPY4018	4.30	4.30	5.50	1.75	1.50	8.00	4.00	2.00	12.00	0.25	2.05
MWPY4020	4.30	4.30	5.50	1.75	1.50	8.00	4.00	2.00	12.00	0.30	2.25
MWPY4030	4.50	4.50	5.50	1.75	1.5	8.00	4.00	2.00	12.00	0.30	3.20
MWPY5020	5.40	5.40	5.50	1.75	1.50	8.00	4.00	2.00	12.00	0.25	2.25
MWPY5040	5.40	5.40	5.50	1.75	1.50	8.00	4.00	2.00	12.00	0.25	4.25
MWPY6020	6.40	6.40	5.50	1.75	1.50	8.00	4.00	2.00	16.00	0.25	2.25
MWPY6028	6.40	6.40	5.50	1.75	1.50	8.00	4.00	2.00	16.00	0.25	3.05
MWPY6045	6.40	6.40	5.50	1.75	1.50	8.00	4.00	2.00	16.00	0.25	4.75
MWPY8040	8.20	8.40	5.50	1.75	1.50	12.00	4.00	2.00	16.00	0.25	4.25

Reel		5Reel / Box		6Box / Carton	
Q'ty(Pcs)	Size m/m	Q'ty(Pcs)	Size m/m	Q'ty(Pcs)	Size m/m
2,000	180 ϕ	10,000	182x182x80	60,000	540x210x205

Reliability test :

NO	Test item	Specification	Test condition	
1-1	High Temperature Exposure	1. No mechanical and electrical damage. 2. Inductance shall not change more than $\pm 20\%$.	1. Temperature: 125°C . 2. Time: 96 hours.	
1-2	Temperature Cycling		1. Temperature: $-40^{\circ}\text{C} \sim +125^{\circ}\text{C}$. 2. Cycles: 96. 3. Dwell time: 30 minutes.	
1-3	Biased Humidity		1. Temperature: 85°C . 2. Humidity: 85%RH. 3. Time: 96 hours.	
1-4	Operational Life		1. Temperature: 125°C (Temp. rise included.). 2. Time: 96 hours.	
1-5	Vibration Test		1. Frequency: 10-2000-10 Hz 2. Test duration: 2 hours for each direction, 6 hours in total. 3. Direction: X, Y, Z	
1-6	Resistance To Soldering Heat Test		1. Method: DIP 2. Temperature: 260 ± 5 3. Time ($\geq 260^{\circ}\text{C}$): 10 Second 4. Number of times: 3	
1-7	Over Load		Applied double current of Isat to inductor for a period of 5 minutes.	
1-8	Solderability Test		The terminal shall be at least 95% covered with fresh solder.	Dip pads in flux then dip in solder pot at 240 ± 5 for 5 seconds.
1-9	Withstanding Voltage Test		1. During the test no breakdown. 2. The characteristic is normal after test.	1. DV: 500V 2. Time: 1 minutes
1-10	Terminal Strength Test		Terminals to withstand the pull of at least want to 1.0 kgf.	1. Pull ≥ 1.0 kgf. 2. Dwell time: 1 minutes

Recommended Lead-Free IR Reflow Conditions :
