

Product Description

The PE9309 is a high-performance dynamic UltraCMOS™ prescaler with a fixed divide ratio of 4. Its operating frequency range is 3.0 GHz to 13.5 GHz. The PE9309 operates on a single supply with a frequency-selecting bias resistor and draws only 16 mA. It is packaged in a small 8-lead Flat Pack and is also available in Die form for Hybrid application.

The PE9309 is manufactured on Peregrine's UltraCMOS™ process, a patented variation of silicon-on-insulator (SOI) technology on a sapphire substrate, offering the performance of GaAs with the economy and integration of conventional CMOS.

Typical Industries

- Medical
- Automotive
- Telecom Infrastructure
- Test Instrumentation
- Down-hole oil/gas
- Military
- Screening available for commercial space applications

Figure 1. Functional Schematic Diagram

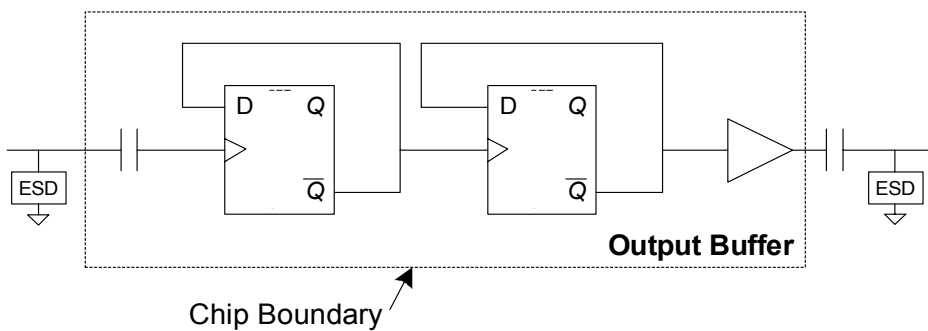

Figure 2. Package Type

8-lead CSOIC



Table 1. Electrical Specifications ($Z_S = Z_L = 50 \Omega$) $-40^\circ \text{C} \leq T_A \leq 85^\circ \text{C}$, unless otherwise specified

Parameter	Conditions	Minimum	Typical	Maximum	Units
Frequency		3.0		13.5	GHz
Output Power (P_{out})	$0.75 \text{ GHz} \leq f_{out} \leq 3.375 \text{ GHz}$	0			dBm
Input Power (P_{in})	$3.0 \text{ GHz} \leq f_{in} < 13.5 \text{ GHz}$	0		7	dBm

Figure 3. Pin Configuration (Top View)

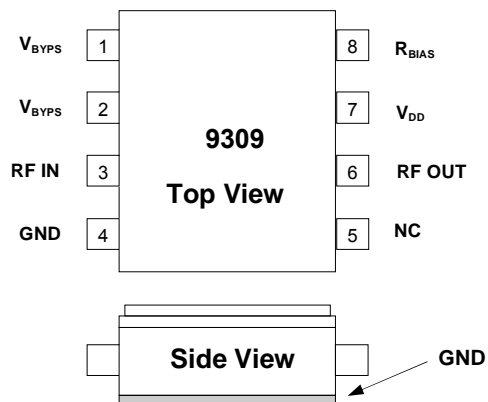

Table 2. Pin Descriptions

Pin No.	Pin Name	Description
1	V _{BYP}	Prescaler Supply Bypass
2	V _{BYP}	Prescaler Supply Bypass
3	IN	RF Input
4	GND	Ground
5	NC	Not Connected
6	OUT	RF Output.
7	V _{DD}	Supply Voltage
8	R _{BIAS}	Frequency-Selecting Bias Resistor
GND	GND	Bottom of the package is Ground. Connecting the bottom of the package to ground is required

Table 3. Operating Ranges

Parameter	Min	Typ	Max	Units
Supply Voltage (V _{DD})	2.45	2.6	2.75	V
Supply Current (I _{DD})	6		23	mA

Electrostatic Discharge (ESD) Precautions

When handling this UltraCMOS™ device, observe the same precautions that you would use with other ESD-sensitive devices. Although this device contains circuitry to protect it from damage due to ESD, precautions should be taken to avoid exceeding the specified rating.

Latch-Up Avoidance

Unlike conventional CMOS devices, UltraCMOS™ devices are immune to latch-up.

Table 4. Absolute Maximum Ratings

Symbol	Parameter/Conditions	Min	Max	Units
V _{DD}	DC Supply voltage		3.0	V
T _{ST}	Storage temperature range	-65	150	°C
T _{OP}	Operating temperature range	-40	85	°C
VESD	ESD voltage (Human Body Model)		250	V
P _{INMAX}	Maximum input power		14	dBm

Exceeding absolute maximum ratings may cause permanent damage. Operation should be restricted to the limits in the Operating Ranges table. Operation between operating range maximum and absolute maximum for extended periods may reduce reliability.

Device Functional Considerations

The PE9309 divides a 3.0 GHz to 13.5 GHz input signal by four, producing a 750 MHz to 3.375 GHz output signal. In order for the prescaler to work properly, several conditions need to be adhered to. It is crucial that pins 1, 2 and 7 be supplied with bypass capacitors to ground. In addition, the output signal (pins 6) needs to be ac coupled via an external capacitor as shown in the test circuit in Figure 5.

The input frequency range is selected by the value of R_{BIAS} according to Figure 4.

The ground pattern on the board should be made as wide as possible to minimize ground impedance.

The bottom of the package is the primary ground connection and it needs to be soldered to the PCB ground.

Figure 4. Frequency versus R_{BIAS}

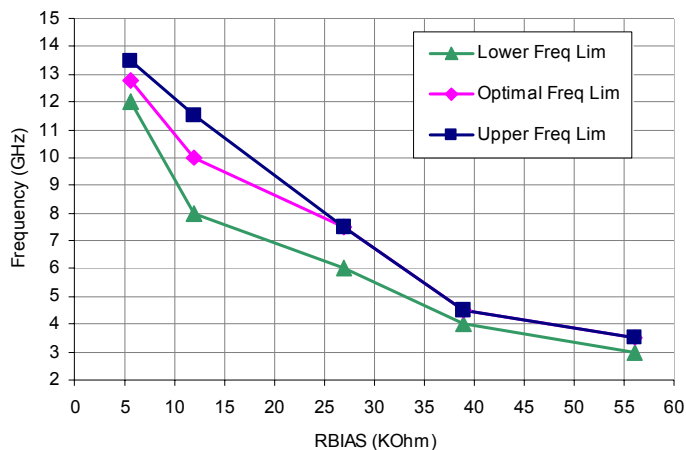

Figure 5. Test Circuit Block Diagram

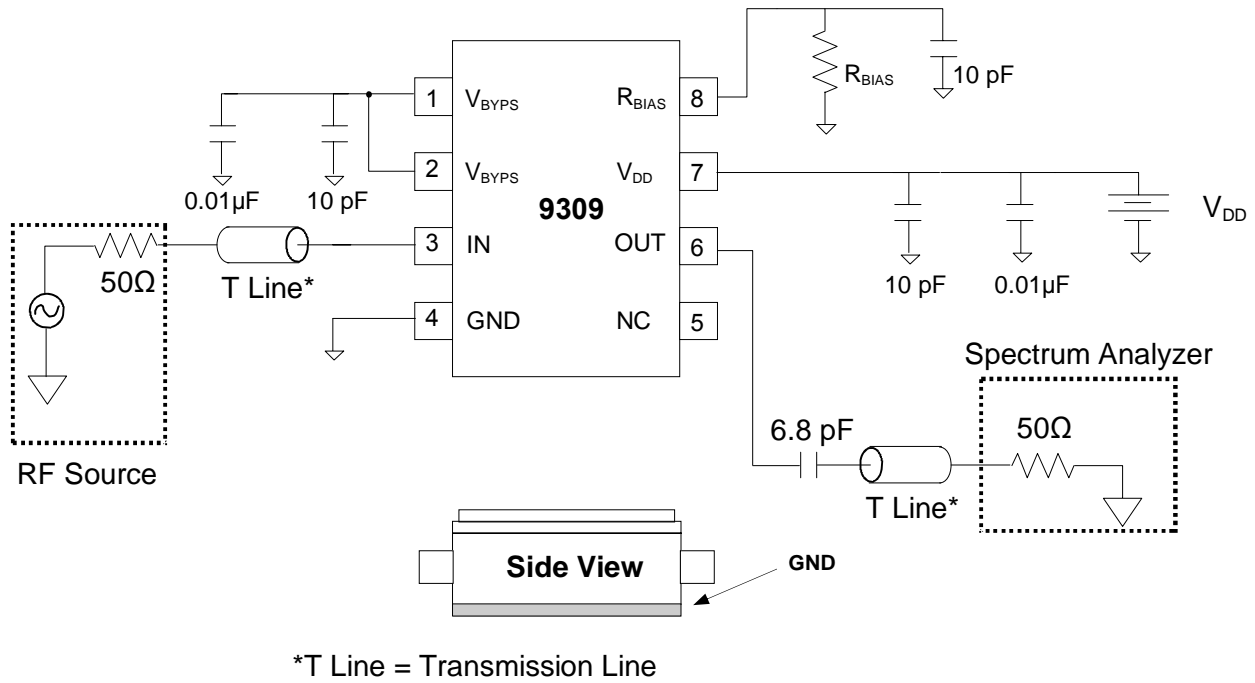
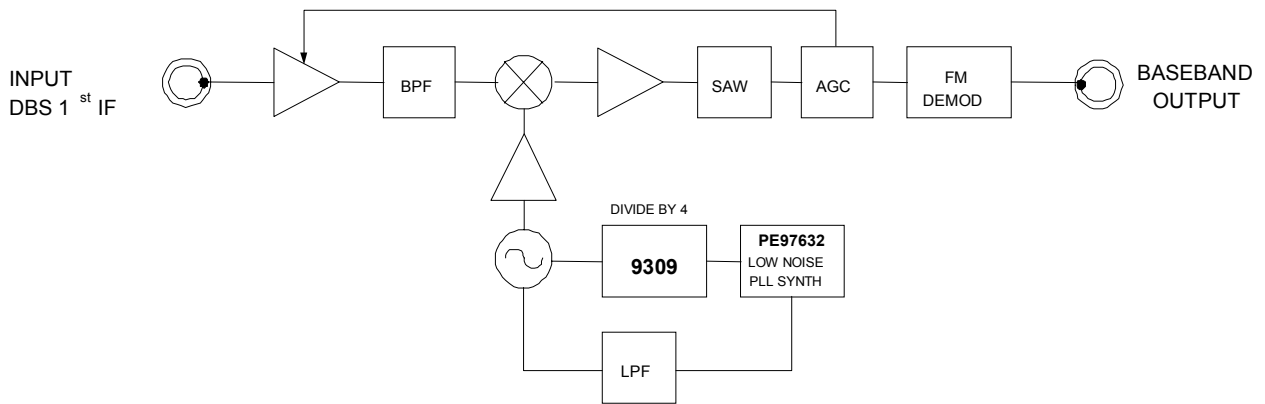

Figure 6. High Frequency System Application

The wideband frequency of operation of the PE9309 makes it an ideal part for use in a DBS down converter system.



Evaluation Kit

The Ceramic SOIC Prescaler Evaluation Board was designed to help customers evaluate the PE9309 divide-by-4 prescaler. On this board, the device input (pin 3) is connected to the SMA connector J5 through a 50 Ω transmission line. The device output (pin 6) is connected to SMA connector J6 through a 50 Ω transmission line.

J4 provides DC power to the device via pin 7. J2 powers U2. Multiple decoupling capacitors (C4,6,13,16=10pF, C3,5,14,15=0.01uF) are used. One out of eight different resistors for R_{BIAS} is selected by toggling SW1, SW2 and SW3 according to the table shown in Figure 8. Jumper on J3 should be on to lower setting (1 and 2). It is the responsibility of the customer to determine proper supply decoupling for their design application. The board is constructed using 4 layers. The top and bottom layers are comprised of Rogers low loss 4350 material having a core thickness of 0.010"; while the internal layers are comprised of FR-4. The overall board thickness is 0.062".

Figure 7. Evaluation Board Layouts
Peregrine Specification 101-0392

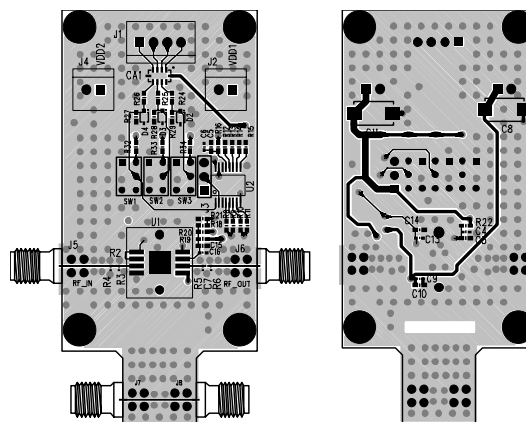

Applications Support

If you have a problem with your evaluation kit or if you have applications questions call (858) 731-9400 and ask for applications support. You may also contact us by fax or e-mail:

Fax: (858) 731-9499
E-Mail: help@psemi.com

Figure 8. Evaluation Board Schematic
Peregrine Specification 102-0468

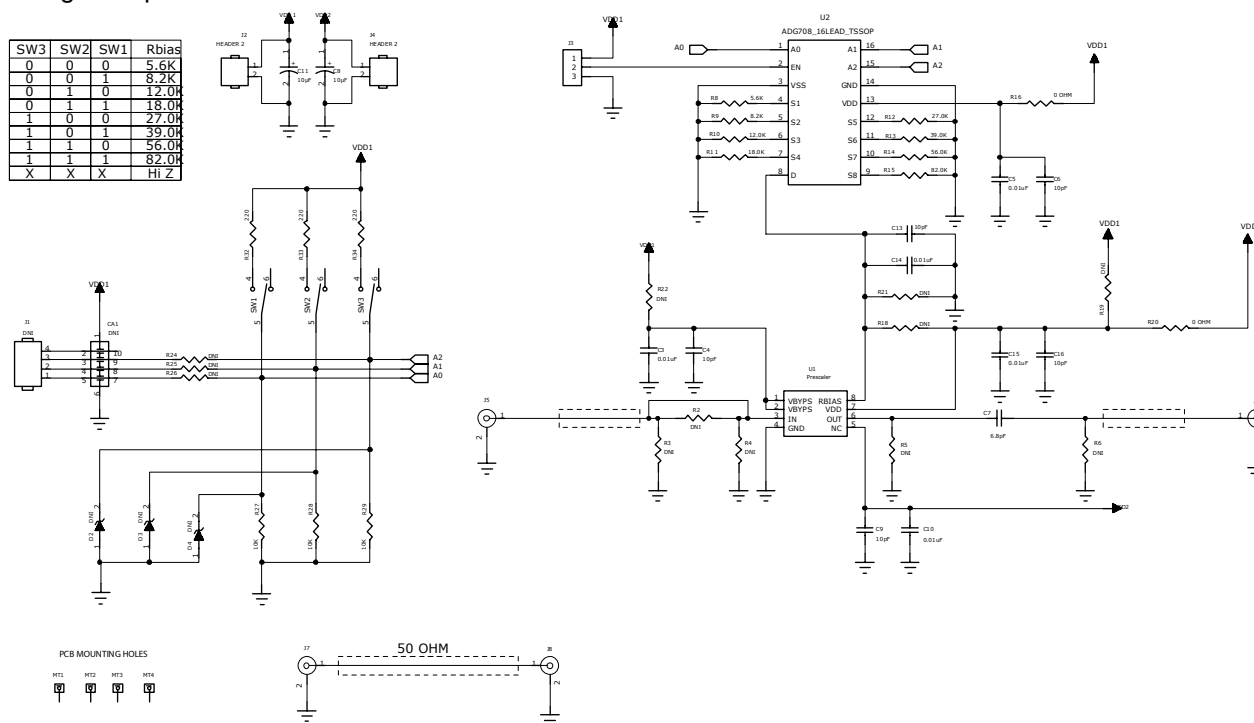

- NOTES:
- USE 101-0392-01 PCB
 - CAUTION: CONTAINS PARTS AND ASSEMBLIES SUSCEPTIBLE TO DAMAGE BY ELECTROSTATIC DISCHARGE (ESD)
 - ALL TRANSMISSION LINES ARE: 35MIL WIDTH, 14MIL GAPS, 20MIL CORE DIELECTRIC 3.48 E1 AND 28MIL CU THICKNESS.

Figure 9. Package Drawing

8-lead CSOIC

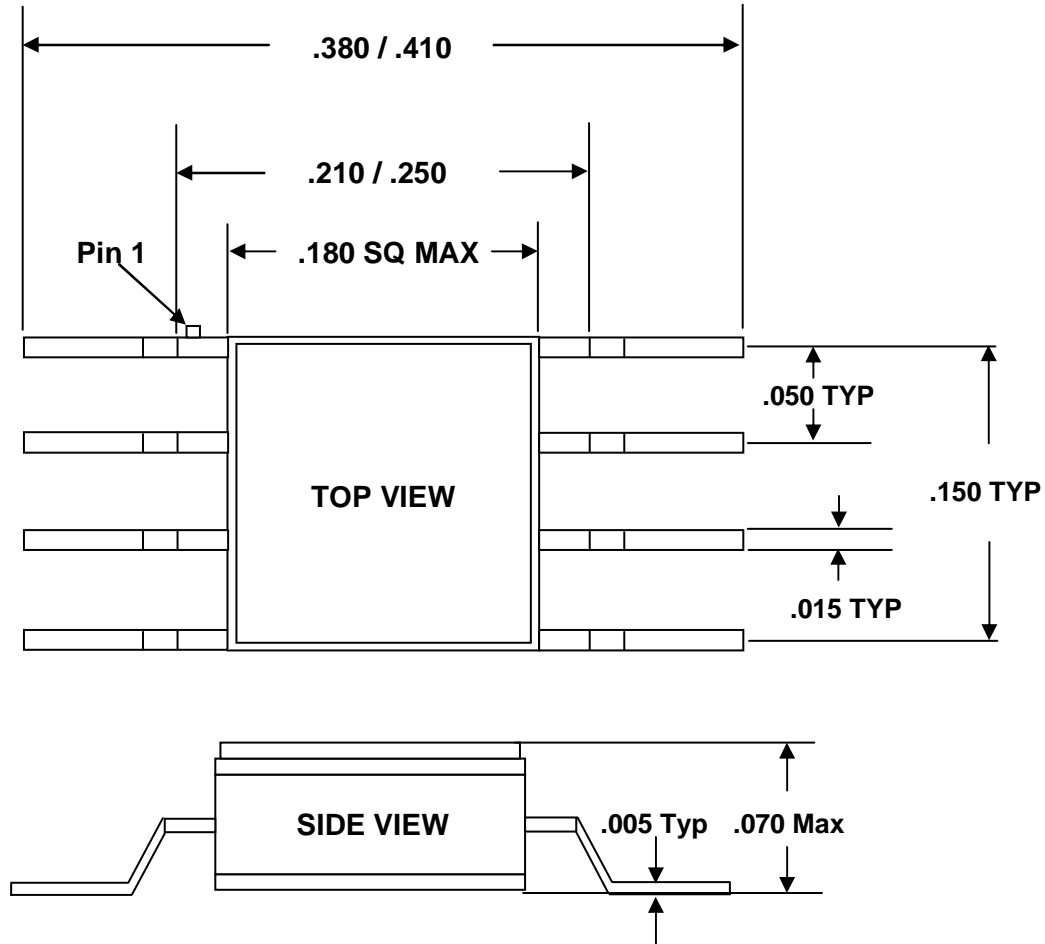

ALL DIMENSIONS ARE IN INCHES
DRAWINGS ARE NOT TO SCALE

Table 5. Ordering Information

Order Code	Part Marking	Description	Package	Screening Specification	Shipping Method
9309-01	9309	PE9309-08CFPJ-B Engineering Samples	8-lead FLAT PACK		50 / Tray
9309-11	9309	PE9309-08CFPJ-B, Production Units	8-lead FLAT PACK	01-0015 ¹	50 / Tray
9309-99	PE9309A	DIE, Production Units	DIE	01-0032 ²	100 / Waffle Pack
9309-00	PE9309-EK	PE9309 Evaluation Kit	Evaluation Board		1 / Box

Notes: 1. Document 01-0015: Quality Requirements for Space Applications

2. Document 01-0032: Quality Requirements for the Evaluation of Semiconductor Dice for Space Applications

Sales Offices

The Americas

Peregrine Semiconductor Corporation

9380 Carroll Park Drive
San Diego, CA 92121
Tel: 858-731-9400
Fax: 858-731-9499

Europe

Peregrine Semiconductor Europe

Bâtiment Maine
13-15 rue des Quatre Vents
F-92380 Garches, France
Tel: +33-1-4741-9173
Fax : +33-1-4741-9173

Hi-Rel and Defense Products

Americas:

Tel: 858-731-9453

Europe, Asia Pacific:

180 Rue Jean de Guiramand
13852 Aix-En-Provence Cedex 3, France
Tel: +33-4-4239-3361
Fax: +33-4-4239-7227

Peregrine Semiconductor, Asia Pacific (APAC)

Shanghai, 200040, P.R. China
Tel: +86-21-5836-8276
Fax: +86-21-5836-7652

Peregrine Semiconductor, Korea

#B-2607, Kolon Tripolis, 210
Geumgok-dong, Bundang-gu, Seongnam-si
Gyeonggi-do, 463-943 South Korea
Tel: +82-31-728-3939
Fax: +82-31-728-3940

Peregrine Semiconductor K.K., Japan

Teikoku Hotel Tower 10B-6
1-1-1 Uchisaiwai-cho, Chiyoda-ku
Tokyo 100-0011 Japan
Tel: +81-3-3502-5211
Fax: +81-3-3502-5213

For a list of representatives in your area, please refer to our Web site at: www.psemi.com

Data Sheet Identification

Advance Information

The product is in a formative or design stage. The data sheet contains design target specifications for product development. Specifications and features may change in any manner without notice.

Preliminary Specification

The data sheet contains preliminary data. Additional data may be added at a later date. Peregrine reserves the right to change specifications at any time without notice in order to supply the best possible product.

Product Specification

The data sheet contains final data. In the event Peregrine decides to change the specifications, Peregrine will notify customers of the intended changes by issuing a DCN (Document Change Notice).

The information in this data sheet is believed to be reliable. However, Peregrine assumes no liability for the use of this information. Use shall be entirely at the user's own risk.

No patent rights or licenses to any circuits described in this data sheet are implied or granted to any third party.

Peregrine's products are not designed or intended for use in devices or systems intended for surgical implant, or in other applications intended to support or sustain life, or in any application in which the failure of the Peregrine product could create a situation in which personal injury or death might occur. Peregrine assumes no liability for damages, including consequential or incidental damages, arising out of the use of its products in such applications.

The Peregrine name, logo, and UTSi are registered trademarks and UltraCMOS, HaRP, MultiSwitch and DuNE are trademarks of Peregrine Semiconductor Corp.