

REMOTE CONTROL ENCODER

DESCRIPTION

The SC5262 is a remote control encoder paired with SC5272 utilizing CMOS technology. It encodes data and address pins into a serial coded waveform suitable for RF or IR modulation. SC5262 has a maximum of 12-bits of tri-state address pins providing up to 531,441 (or 3^{12}) address codes; thereby, drastically reducing any code collision and unauthorized code scanning possibilities.

FEATURES

- * Low power consumption and very high noise immunity
- * Up to 12 tri-state code address pins or 6 data pins
- * Wide operating voltage range ($V_{CC}=3V \sim 15V$)
- * Single resistor oscillator
- * Latch or Momentary output type

APPLICATION

- * Home/automation security system
- * Remote control toys or for industrial use
- * Remote control fan
- * Garage door controller

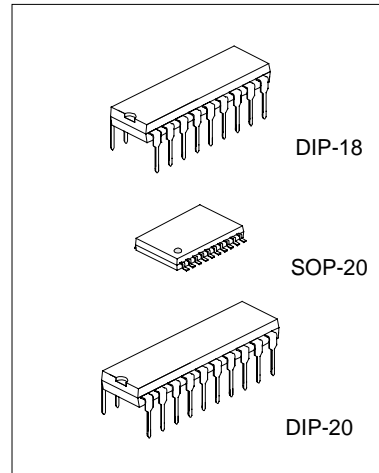

ORDERING INFORMATION

SC5262X-XX

- RF: RF Applicant, normally omitted
- IR: IR Applicant
- S: SOP-20 Package
- D: DIP-20 Package
- Omitted: DIP-18 Package

PIN CONFIGURATION

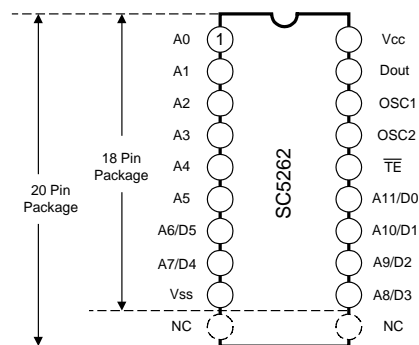

BLOCK DIAGRAM

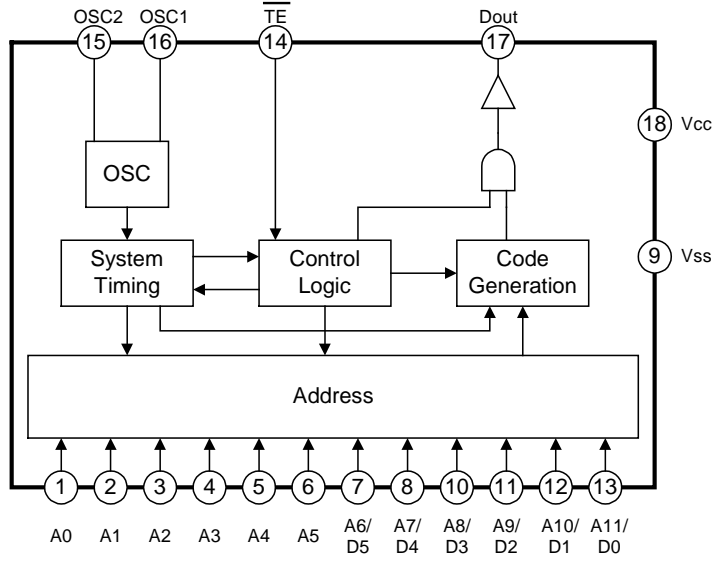

The block diagram is for DIP-18(hereinafter is the same)

ABSOLUTE MAXIMUM RATINGS($T_a=25^{\circ}\text{C}$)

Characteristic	Symbol	Value	Unit
Supply Voltage	Vcc	-0.3 ~ 16.0	V
Input Voltage	Vi	-0.3 ~ Vcc+0.3	V
Output Voltage	Vo	-0.3 ~ Vcc+0.3	V
Maximum Power Dissipation(Vcc=12V)	Pa	300	mW
Operating Temperature	Topr	-20 ~ +70	°C
Storage Temperature	Tstg	-40 ~ +125	°C

ELECTRICAL CHARACTERISTICS

($T_a=25^{\circ}\text{C}$, Vcc=12V, unless otherwise specified)

Characteristic	Symbol	Test Condition	Min	Typ.	Max	Unit
Supply Voltage	Vcc		3		15	V
Supply Current	Icc	Vcc=12V, OSC stops A0~ A11 Open		0.02	0.3	μA
Dout Output driving Current	IOH	Vcc=5V, VOH=3V	-3			mA
		Vcc=8V, VOH=4V	-6			mA
		Vcc=12V, VOH=6V	-10			mA
Dout Output sinking Current	IOL	Vcc=5V, VOL=3V	2			mA
		Vcc=8V, VOL=4V	5			mA
		Vcc=12V, VOL=6V	9			mA

PIN DESCRIPTION

Pin No.		Pin Name	I/O	Description
18 PIN	20 PIN			
1~6	1~6	A0~A5	I	Code Address pins No. 0~5. These six tri-state pins are detected by SC5262 to determine the encoded waveform bit 0 ~bit 5. Each pin can be set to "0", "1", "f"(floating).
7~8 10~13	7~8 12~15	A6/D5~A11/D0	I	Code Address pinsNo.6~11/data pins No.5~0. These six tri-state pins are detected by SC5262 to determine the encoded waveform bit 6 ~bit 11.When these pins are used as address pins, they can be set to "0", "1", "f".When they are used as data pins ,they can be set only to "0", "1".
14	16	\overline{TE}	I	Transmission Enable. Active Low Signal.SC5262 outputs the encoded waveform to DOUT when this pins is pulled to LOW.
15	17	OSC1	O	Oscillator Pin No.1
16	18	OSC2	I	Oscillator Pin No.2
17	19	DOUT	O	Data Output Pin. The encoded waveform is serially outputted to this pin. When SC5262 is not transmitting, DOUT outputs low(Vss) voltage.
18	20	Vcc	--	Positive Power Supply
9	9	Vss	--	Negative Power Supply
--	10~11	NC	--	Not Connected

FUNCTIONAL DESCRIPTION

The SC5262 encodes the code address and data set at A0~ A5 and A6/D5 ~ A11/D0 into a special waveform and outputs it to the Dout when \overline{TE} is pulled to "0" (Low state). This waveform is fed to either the RF modulator or the IR transmitter for transmission. The Transmitted radio frequency or infrared ray is received by the RF demodulator or IR receiver and reshaped to the special waveform. SC5272 is then used to decode the waveform and set the corresponding output pins. Thus completing a remote control encoding and decoding function.

1. RF OPERATION

Code Bits

A code bit is the basic component of the encoded waveform, and can be classified as either an AD(Address/Data) Bit or a SYNC(Synchronous) Bit.

An AD bit can be designated as bit " 0 ", " 1 " or " f " if it is in low, high or floating state respectively. One bit waveform consists of two pulse cycles. Each pulse cycle has 16 oscillating time periods. For further details, please refer to the diagram below:

The Synchronous bit waveform is 4 bits long with 1/8 bit width pulse. Please refer to the diagram below:

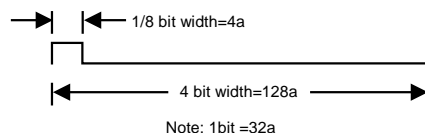

Code word

A group of Code Bits is called a Code Word. A Code Word consists of 12 AD bits followed by one Sync. Bit. The 12 AD bits are determined by the corresponding states of A0~A5 and A6/D5 ~ A11/D0 pins at the time of transmission. When Data Type of SC5262 is used, the address bits will decrease accordingly. For example, in the 3 Data Type where the address has 9 bits, the transmitting format is:

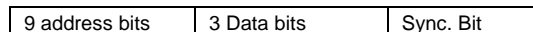

SC5262/SC5272 has a maximum of 12 Address Bits including the 6 Address/Data bits. The following diagram shows the code bits with their corresponding pins.

A0	A1	A2	A3	A4	A5	A6 /D5	A7 /D4	A8 /D3	A9 /D2	A10 /D1	A11 /D0
----	----	----	----	----	----	-----------	-----------	-----------	-----------	------------	------------

0 Data	A0	A1	A2	A3	A4	A5	A6	A7	A8	A9	A10	A11	Sync
1 Data	A0	A1	A2	A3	A4	A5	A6	A7	A8	A9	A10	D0	Sync
2 Data	A0	A1	A2	A3	A4	A5	A6	A7	A8	A9	D1	D0	Sync
3 Data	A0	A1	A2	A3	A4	A5	A6	A7	A8	D2	D1	D0	Sync
4 Data	A0	A1	A2	A3	A4	A5	A6	A7	D3	D2	D1	D0	Sync
5 Data	A0	A1	A2	A3	A4	A5	A6	D4	D3	D2	D1	D0	Sync
6 Data	A0	A1	A2	A3	A4	A5	D5	D4	D3	D2	D1	D0	Sync

The Code Bits A0~A5 and A6/D5 ~ A11/D0 are determined by the states of A0 ~ A5 and A6/D5 ~A11/D0 pins. For example, when the A0(pin 1) is set to "1"(Vcc), the code bit A0 is synthesized as "1" bit. In the same manner, when it (A0 pin) is set to "0"(Vss) or left floating, the Code Bit A0 is synthesized as a "0" or "f" bit respectively.

Code Frame

A Code Frame consists of 4 continuous code Words. When SC5262 detects "0" on the \overline{TE} (meaning, the \overline{TE} is active "low"), it outputs a Code frame at Dout. If \overline{TE} is still active at the time the Code Frame transmission ends. SC5262 outputs another Code Frame. It should be noted that the Code Frame is synthesized at the time of transmission.

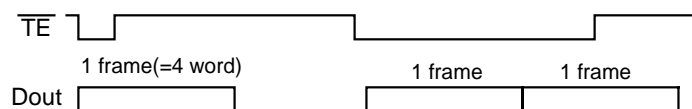

Single Resistor Oscillator

The Build-in oscillator circuitry of SC5262 allows a precision oscillator to be constructed by connecting an external resistor between OSC1 and OSC2 pins. For SC5272 to decode correctly the received waveform, the oscillator frequency of SC5272 must be 2.5 ~8 times that of transmitting SC5262. The typical oscillator frequency with various resistor values for both SC5262 and SC5272 are shown below:

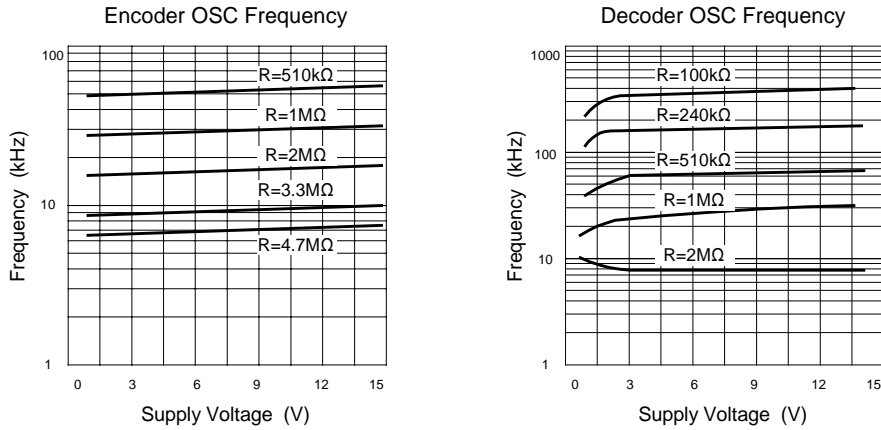

Suggested Oscillator resistor values are shown below:

SC5262	SC5272
4.7MΩ	820kΩ
3.3MΩ	680kΩ
1.2MΩ	200kΩ

2. IR OPERATION

In the IR Type of operation, the functions are similar to the above descriptions except for the output waveform that has a carrier frequency of 38kHz. Details are as follow.

Code Bits

The Code Bits are further modulated with a 38kHz carrier frequency and can be "0", "1" or "f" bit. Their waveform are shown below:

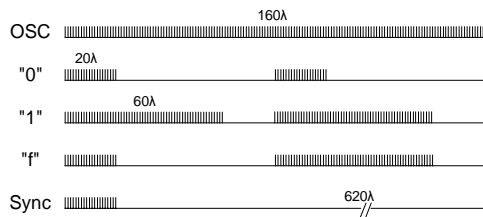

Note:λ=2 clock lengths

Code Word

A Code Word is made up of code bits and the format is the same as that of the RF Code Word.

Code Frame

Likewise, a Code Frame is made up of Code Words and the format is the same as that of RF type of operation.

Oscillator

The oscillator frequency for the IR type of operation is twice the carrier frequency. Thus, the oscillator frequency should be kept at 76kHz. A 430k~470kΩ oscillator resistor between OSC1 and OSC2 pins is recommended. It should be noted that the carrier is a 50% duty cycle frequency.

OPERATION FLOW CHART

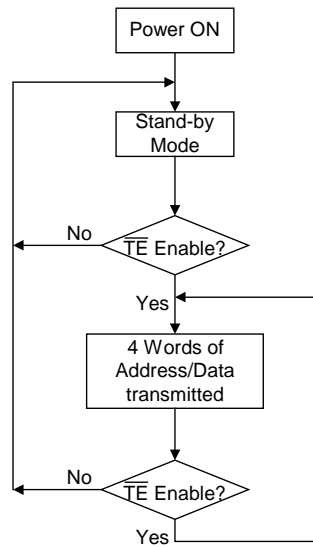

TYPICAL APPLICATION CIRCUIT

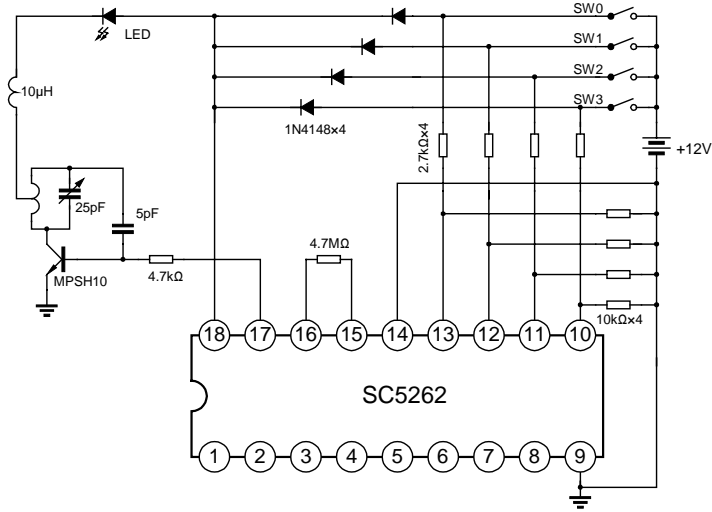

UHF Band 4 Data Transmitter Circuit is recommended.

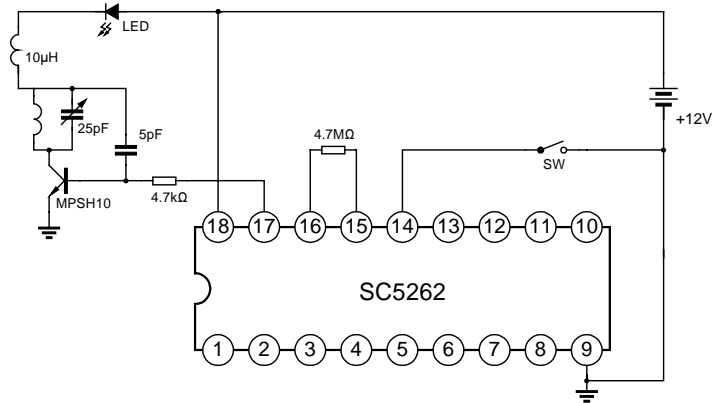

UHF Band Address-only(o data) Transmitter Circuit is recommended.

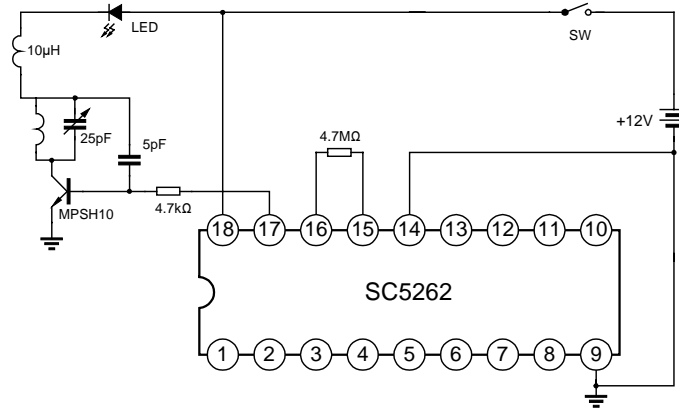

UHF Band Address-only(o data) Zero-stand-by Transmitter Circuit is recommended.

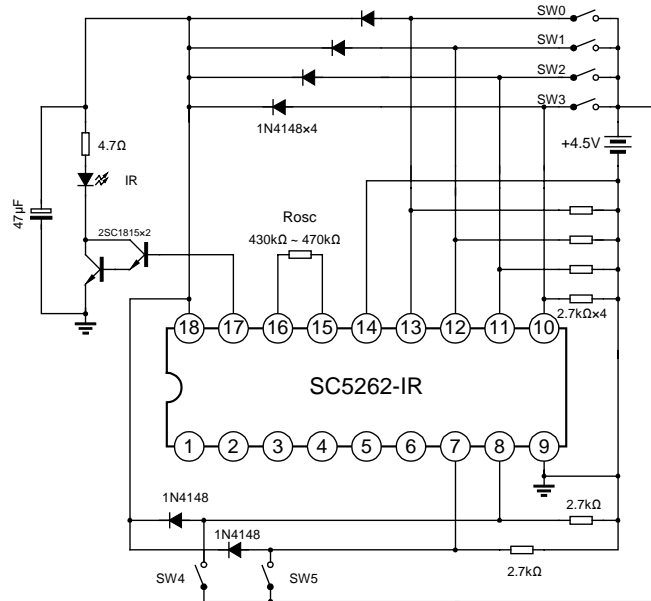

Infrared Ray 6-data circuit. Adjust Rosc to get 38kHz carrier pulse at Dout pin is recommended.

PACKAGE OUTLINE

