

ES-2115/2215

15" Open Frame and Rugged Panel Mount Monitor



Features

- 15" LCD supports 1024 x 768 pixels and wide operating temperature (-0 ~ 50° C)
- Resistive, Capacitive, SAW or IR touchscreen and 3 mm tempered glass options
- Versatile mounting brackets
- Modular architecture for efficient integration
- Special back cover designed for 3.5"/5.25" SBCs and ARK-1000/3000/4000 series box computers
- Sunlight readable (optional)
- Ultra-high brightness up to 1000 cd/m2 with LED backlight technology (optional)
- Rugged aluminum front bezel design (ES-2215)
- VGA or LVDS interface (S-Video: optional)

Introduction

The Advantech ES-2115/2215 Embedded Open Frame and Rugged Panel Mount Monitor series offer flexible options for LCD, touchscreen, signal interface and chassis mounting. The back cover has mounting holes for industry standard 3.5" or 5.25" SBCs; or Advantech DSA-2102, DSA-3400 digital signage player, DVS-355 mobile digital video platform, and ARK-1000, ARK-3000 and ARK-4000 series embedded box computers. The series supports panel and VESA mounting, and is supplied with four versatile mounting brackets for different integration applications. The Advantech Display Solutions Selection Wizard (<http://www.advantech.com.tw/ePlatform/DS/DisplaySolution.asp>) enables easy selection of model numbers by choosing the required options.

Specifications

Processor System	I/O Ports	15-pin D-sub, DC power input, RS-232 port, Power Switch and OSD keys (Auto-tune, menu, decrease, increase)			
	Display Input Signal	Analog RGB, 0.7 VP-P / 75 Ohm, optional LVDS			
	Multi-Scan Mode	Multi-Scan Mode supports VGA, SVGA			
	OSD Control	Keys: Auto-tune, Menu, Decrease and Increase Functions: Brightness, Contrast, Clock, Phase, Horizontal Position, Vertical Position and Sharpness			
	Power	50 W power adapter, with AC 100 ~ 240 V input and DC +12 V @ 4.16 A output			
	Dimensions (W x H x D)	Please refer to the product dimension diagram on next page			
	Weight	ES-2115: 3.8 kg / 8.38 lb ES-2215: 4.5 kg / 9.92 lb			
Environment	Operating Temperature	-0 ~ 50° C (32 ~ 122° F)			
	Storage Temperature	-20 ~ 60° C (-4 ~ 140° F) for standard LCDs			
	Humidity	5 ~ 95% @ 40° C, non-condensing			
	Shock	10 G peak acceleration (11 ms duration)			
	EMC Approved	CE FCC			
Display	Feature	Standard / (OEM)	Sunlight Readable	Ultra-high Brightness	
	Size	15"	15"	15"	
	Resolution (pixels)	1024 x 768 XGA	1024 x 768 XGA	1024 x 768 XGA	
	Number of Colors	262 K	262 K	262 K	
	Viewing Angle (L/R/U/D)	60°/60°/40°/60°	70°/70°/70°/50°	60°/60°/35°/65°	
	Brightness (cd/m2)	350	550	1500	
	Contrast Ratio	500:1	500:1	650:1	
	Response Time (ms)	12	12	6	
	Lamp Life (hrs)	50,000	50,000	50,000	
	Long-term Support	Yes	Yes	Yes	
	Anti-reflection	-	Yes	Yes	
Touchscreen	Type	Analog Resistive	Capacitive	SAW	Infrared
	Thickness	3.48 mm	3.18 mm	2.7 mm	3.0 mm
	Resolution	4096 x 4096	1024 x 1024	4096 x 4096	4096 x 4096
	Light Transmission	80%	85%	92%	92%
	Controller Interface	RS-232/USB	RS-232	RS-232/USB	RS-232/USB
	Power Consumption	+5 V @ 200 mA	+5 V @ 100 mA	+5 V @ 75 mA	+5 V @ 150 mA
	Durability (Touches)	35 million hrs	225 million hrs	50 million hrs	MTBF 100,000 hrs
	Driver OS Support	DOS, Linux, Mac, Windows 95/98/NT/ME/CE/2000/XP			

Dimensions

Unit: mm

ES-2115

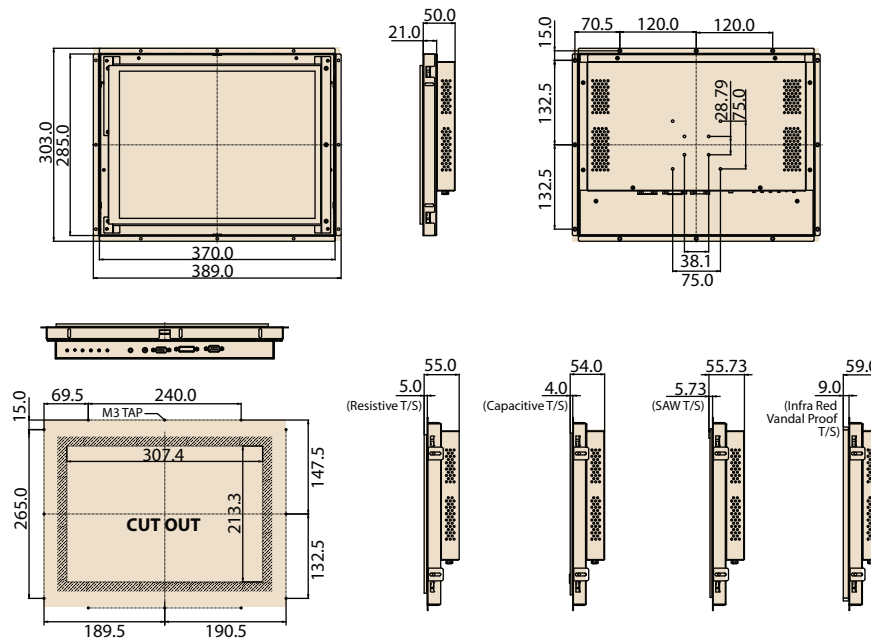

ES-2215

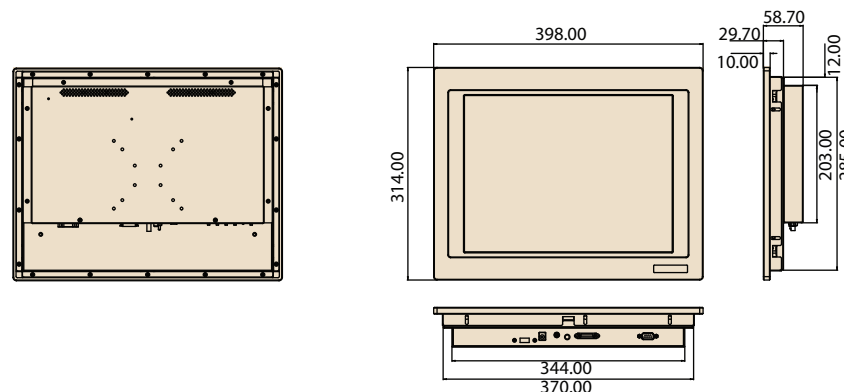

Ordering Information

P/N	Type	Brightness (cd/m ²)	Interface	Touchscreen	Touch Interface	Anti-Reflection
ES-2115G-VXAE	Open Frame	350	VGA	Tempered Glass	N/A	N/A
ES-2115R-VXAE	Open Frame	350	VGA	5-Wire Resistive	RS-232/USB	N/A
ES-2115C-VXAE	Open Frame	350	VGA	Capacitive	RS-232	N/A
ES-2115R-LXAE-05	Open Frame	350	LVDS	5-Wire Resistive	RS-232/USB	N/A
ES-2215R-VXAE	Rugged panel mount	350	VGA	5-Wire Resistive	RS-232/USB	N/A
ES-2215C-VXA-SRE	Rugged panel mount	550	VGA	Capacitive	RS-232	Yes
ES-2115C-VXM-HE	Open Frame	1500	VGA	Capacitive	RS-232	Yes

Notes:

- 1.) Capacitive, SAW and Infrared touch panels are recommended for applications requiring sunlight readable outdoor solutions.
- 2.) The list above is of major part numbers for your reference. Other combinations of LCD, touchscreen and signal interface features can be found in the Advantech Display Solutions. The Selection Wizard (<http://www.advantech.com.tw/ePlatform/DS/DisplaySolution.asp>) or CTOS services can be used to get your demand configuration and part numbers to us for ordering.
- 3.) For special requests, we welcome you to use the Display Solution DTOS service.