

# CGH35060F1 / CGH35060P1

60 W, 3.3-3.6 GHz, 28V, GaN HEMT for WiMAX, Broadband Wireless Access

Cree's CGH35060F is a gallium nitride (GaN) high electron mobility transistor (HEMT) designed specifically for high efficiency, high gain and wide bandwidth capabilities, which makes the CGH35060F ideal for 3.3-3.6 GHz WiMAX and BWA linear amplifier applications. The transistor is supplied in a ceramic/metal flange and pill package. Cree GaN-on-SiC HEMTs are highly correctable, enabling even greater efficiency when used with digital pre-distortion (DPD).

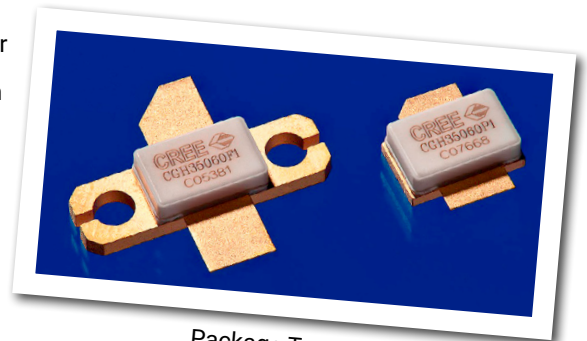

Package Type: 440193 & 440196  
PN: CGH35060F1 & CGH35060P1

## Typical Performance Over 3.3-3.6GHz ( $T_c = 25^\circ\text{C}$ ) of Demonstration Amplifier

Parameter	3.3 GHz	3.4 GHz	3.5 GHz	3.6 GHz	Units
Small Signal Gain	11.7	12.2	12.6	12.8	dB
EVM @ 26 dBm	2.05	1.82	1.56	1.80	%
EVM @ 39 dBm	1.91	1.83	1.98	2.86	%
Drain Efficiency @ 39 dBm	22.0	23.1	24.9	26.7	%
Input Return Loss	8.0	10.3	12.5	13.1	dB

**Note:**

Measured in the CGH35060F1-AMP amplifier circuit, under 802.16 OFDM, 3.5 MHz Channel BW, 1/4 Cyclic Prefix, 64 QAM Modulated Burst, 5 ms Burst, Symbol Length of 59, Coding Type RS-CC, Coding Rate Type 2/3, PAR = 9.8 dB @ 0.01 % Probability on CCDF.

## Features

- 3.3 - 3.6 GHz Operation
- 60 W Peak Power Capability
- 12 dB Small Signal Gain
- 8.0 W  $P_{AVE}$  at < 2.0 % EVM
- 25 % Drain Efficiency at 8 W  $P_{AVE}$
- WiMAX Fixed Access 802.16-2004 OFDM
- WiMAX Mobile Access 802.16e OFDMA



Large Signal Models Available for ADS and MWO

## Absolute Maximum Ratings (not simultaneous) at 25°C Case Temperature

Parameter	Symbol	Rating	Units	Conditions
Drain-Source Voltage	$V_{DS}$	84	Volts	25°C
Gate-to-Source Voltage	$V_{GS}$	-10, +2	Volts	25°C
Power Dissipation	$P_{DISS}$	28	Watts	
Storage Temperature	$T_{STG}$	-65, +150	°C	
Operating Junction Temperature	$T_J$	225	°C	
Maximum Forward Gate Current	$I_{GMAX}$	15	mA	25°C
Maximum Drain Current <sup>1</sup>	$I_{MAX}$	6	A	25°C
Soldering Temperature <sup>2</sup>	$T_S$	245	°C	
Screw Torque	$\tau$	80	in-oz	
Thermal Resistance, Junction to Case <sup>3</sup>	$R_{\theta JC}$	2.8	°C/W	85°C
Case Operating Temperature <sup>3</sup>	$T_C$	-40, +150	°C	

Note:

<sup>1</sup> Current limit for long term, reliable operation.

<sup>2</sup> Refer to the Application Note on soldering at [www.cree.com/RF/Document-Library](http://www.cree.com/RF/Document-Library)

<sup>3</sup> Measured for the CGH35060F1 at  $P_{DISS} = 28$  W.

## Electrical Characteristics ( $T_C = 25^\circ\text{C}$ )

Characteristics	Symbol	Min.	Typ.	Max.	Units	Conditions
<b>DC Characteristics<sup>1</sup></b>						
Gate Threshold Voltage	$V_{GS(th)}$	-3.8	-3.0	-2.3	$V_{DC}$	$V_{DS} = 10$ V, $I_D = 14.4$ mA
Gate Quiescent Voltage	$V_{GS(Q)}$	-	-3.0	-	$V_{DC}$	$V_{DS} = 28$ V, $I_D = 250$ mA
Saturated Drain Current	$I_{DS}$	11.6	14.0	-	A	$V_{DS} = 6.0$ V, $V_{GS} = 2$ V
Drain-Source Breakdown Voltage	$V_{BR}$	120	-	-	$V_{DC}$	$V_{GS} = -8$ V, $I_D = 14.4$ mA
<b>RF Characteristics<sup>2,3</sup> (<math>T_C = 25^\circ\text{C}</math>, <math>F_0 = 3.5</math> GHz unless otherwise noted)</b>						
Small Signal Gain	$G_{SS}$	10	11.5	-	dB	$V_{DD} = 28$ V, $I_{DQ} = 250$ mA
Drain Efficiency <sup>4</sup>	$\eta$	19	23	-	%	$V_{DD} = 28$ V, $I_{DQ} = 250$ mA, $P_{AVE} = 8$ W
Back-Off Error Vector Magnitude	$EVM_1$	-	2.5	-	%	$V_{DD} = 28$ V, $I_{DQ} = 250$ mA, $P_{AVE} = 24$ dBm
Error Vector Magnitude	$EVM_2$	-	2.0	2.5	%	$V_{DD} = 28$ V, $I_{DQ} = 250$ mA, $P_{AVE} = 8$ W
Output Mismatch Stress	VSWR	-	-	10:1	$\Psi$	No damage at all phase angles, $V_{DD} = 28$ V, $I_{DQ} = 250$ mA
<b>Dynamic Characteristics</b>						
Input Capacitance	$C_{GS}$	-	19.0	-	pF	$V_{DS} = 28$ V, $V_{GS} = -8$ V, $f = 1$ MHz
Output Capacitance	$C_{DS}$	-	5.9	-	pF	$V_{DS} = 28$ V, $V_{GS} = -8$ V, $f = 1$ MHz
Feedback Capacitance	$C_{GD}$	-	0.8	-	pF	$V_{DS} = 28$ V, $V_{GS} = -8$ V, $f = 1$ MHz

Notes:

<sup>1</sup> Measured on wafer prior to packaging.

<sup>2</sup> Measured in the CGH35060F1-AMP test fixture.

<sup>3</sup> Under 802.16 OFDM, 3.5 MHz Channel BW, 1/4 Cyclic Prefix, 64 QAM Modulated Burst, 5 ms Burst, Symbol Length of 59, Coding Type RS-CC, Coding Rate Type 2/3, PAR = 9.8 dB @ 0.01 % Probability on CCDF.

<sup>4</sup> Drain Efficiency =  $P_{out} / P_{DC}$ .

## Typical WiMAX Performance

Gain and Return Loss vs Frequency measured in Broadband Amplifier Circuit CGH35060F1-AMP,  $V_{DD} = 28\text{ V}$ ,  $I_{DQ} = 250\text{ mA}$

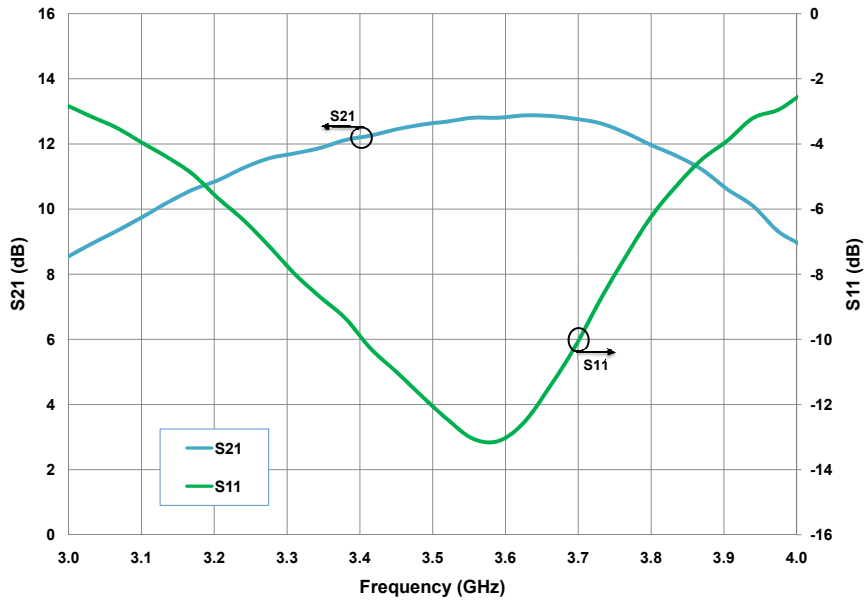

Typical EVM at 26 dBm and 39 dBm, and Efficiency vs Frequency measured in Broadband Amplifier Circuit CGH35060F1-AMP,  $V_{DD} = 28\text{ V}$ ,  $I_{DQ} = 250\text{ mA}$

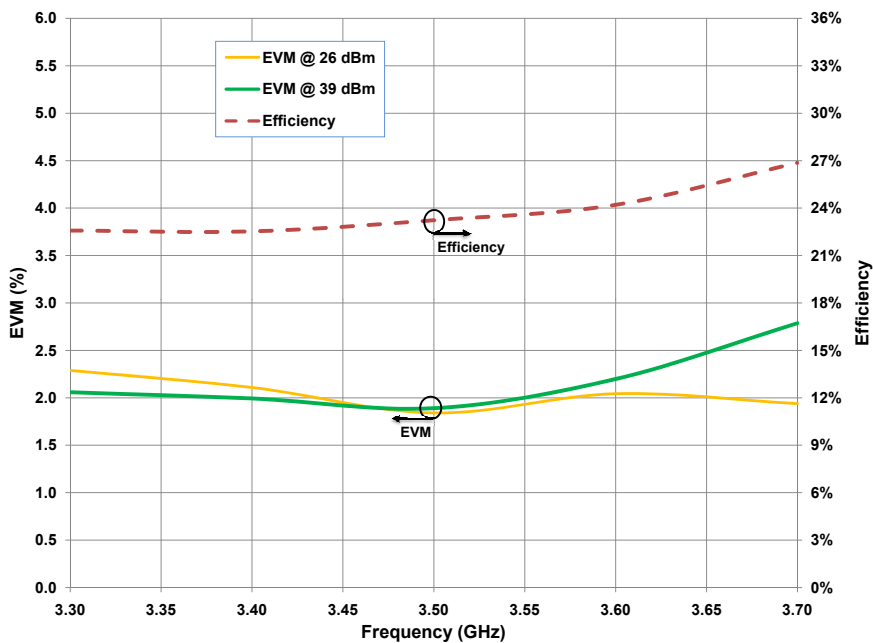

Note:  
Under 802.16-2004 OFDM, 3.5 MHz Channel BW, 1/4 Cyclic Prefix, 64 QAM Modulated Burst, Symbol Length of 59, Coding Type RS-CC, Coding Rate Type 2/3.

## Typical WiMAX Performance

**Drain Efficiency and Gain vs Output Power measured in the CGH35060F1-AMP,  
 $V_{DD} = 28\text{ V}$ ,  $I_{DQ} = 250\text{ mA}$ , 802.16-2004 OFDM, PAR = 9.8 dB**

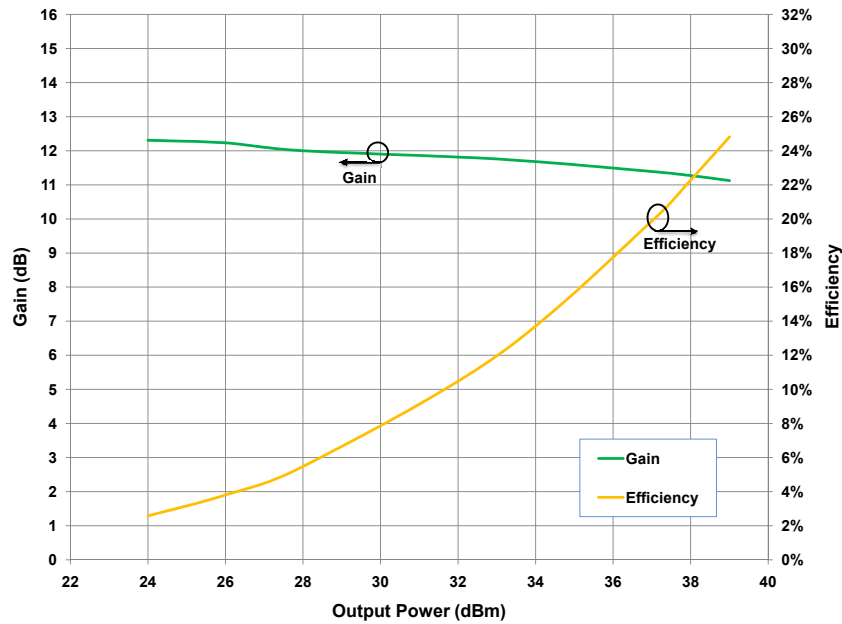

**Typical EVM and Efficiency vs Output Power measured in the CGH35060F1-AMP,  
 $V_{DD} = 28\text{ V}$ ,  $I_{DQ} = 250\text{ mA}$ , 802.16-2004 OFDM, PAR=9.8 dB**

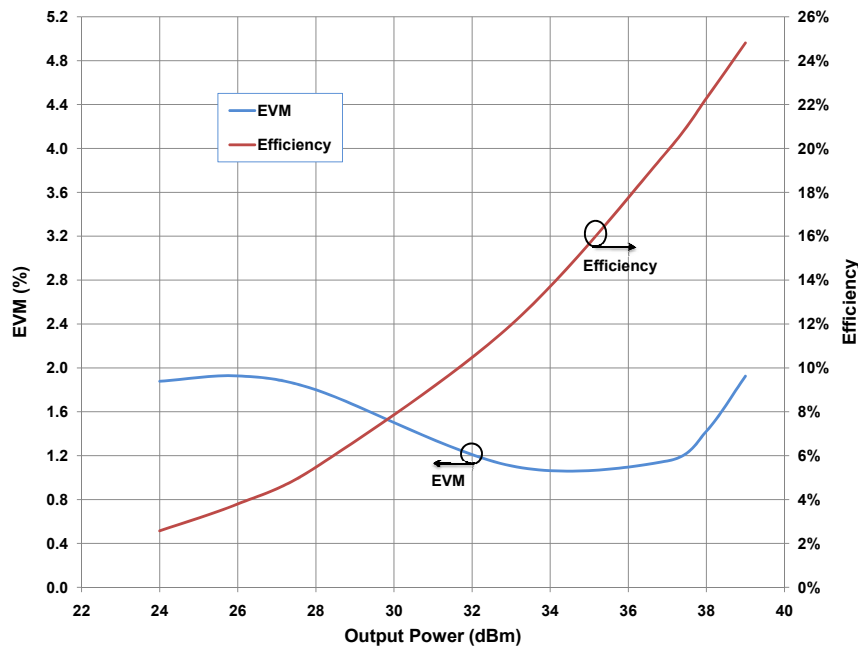

Note:  
 Under 802.16-2004 OFDM, 3.5 MHz Channel BW, 1/4 Cyclic Prefix, 64 QAM Modulated Burst,  
 Symbol Length of 59, Coding Type RS-CC, Coding Rate Type 2/3.

## Typical Performance Data

**Simulated Maximum Available Gain and K Factor of the CGH35060F1 and CGH35060P1**  
 $V_{DD} = 28\text{ V}, I_{DQ} = 250\text{ mA}$

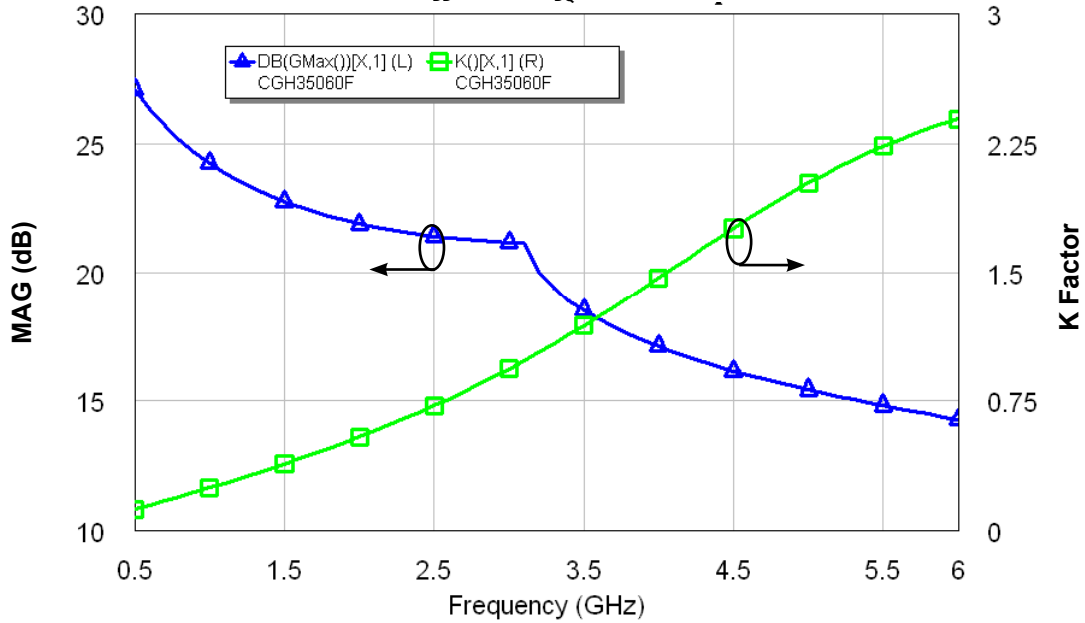

## Typical Noise Performance

**Simulated Minimum Noise Figure and Noise Resistance vs Frequency of the CGH35060**  
 $V_{DD} = 28\text{ V}, I_{DQ} = 250\text{ mA}$

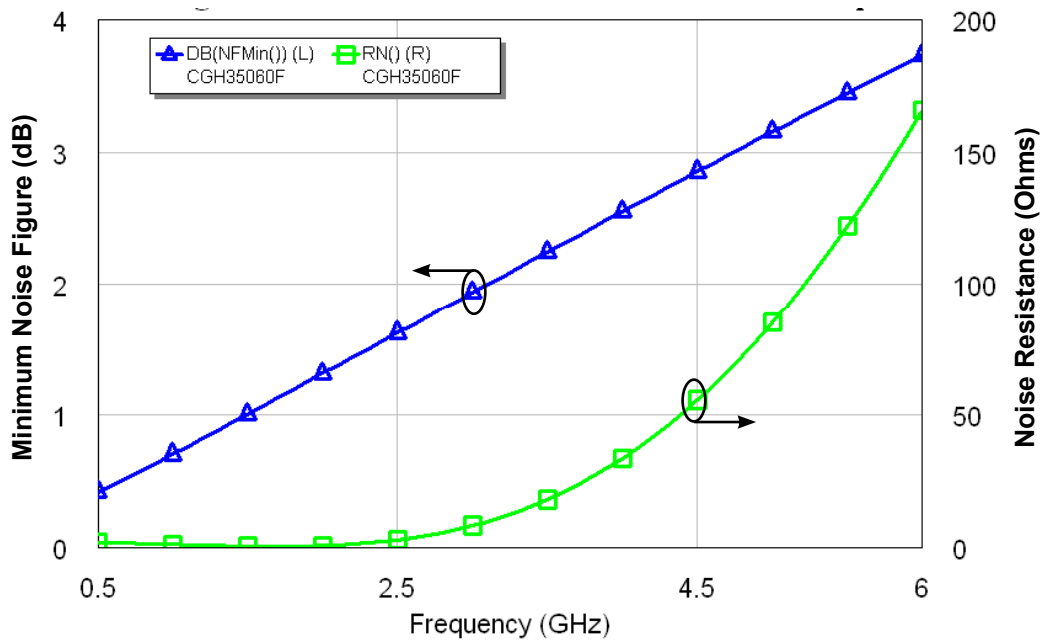

## Source and Load Impedances

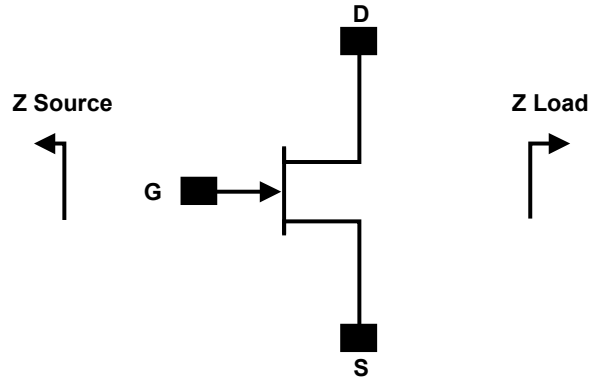

Frequency (MHz)	Z Source	Z Load
3300	3.5 - j12.1	6.5 - j6.8
3400	3.5 - j11.4	6.0 - j5.9
3500	3.3 - j10.7	5.6 - j5.1
3600	3.2 - j10.0	5.4 - j4.3

Note<sup>1</sup>:  $V_{DD} = 28V$ ,  $I_{DQ} = 250mA$ . In the 440193 package.

Note<sup>2</sup>: Impedances are extracted from the CGH35060F1-AMP demonstration circuit and are not source and load pull data derived from the transistor.

## Electrostatic Discharge (ESD) Classifications

Parameter	Symbol	Class	Test Methodology
Human Body Model	HBM	1A (> 250 V)	JEDEC JESD22 A114-D
Charge Device Model	CDM	II (200 < 500 V)	JEDEC JESD22 C101-C

## CGH35060F1-AMP Demonstration Amplifier Circuit Bill of Materials

Designator	Description	Qty
R1	RES, 1/16W, 0603, 1%, 5.1 OHMS	1
R2	RES, 1/16W, 0603, 1%, 100 OHMS	1
C6,C13,C19	CAP, 470pF, 5%, 100V, 0603	3
C16,C22	CAP, 33 UF, 20%, G CASE	2
C15,C21	CAP, 1.0UF, 100V, 10%, X7R, 1210	2
C8	CAP 10UF 16V TANTALUM	1
C4,C11,C17	CAP, 7.5pF, +/-0.1pF, 0603, ATC	3
C1	CAP, 0.6pF, +/-0.05pF, 0603, ATC	2
C2	CAP, 1.2pF, +/-0.1pF, 0603, ATC	1
C10	CAP, 4.7pF, +/-0.25pF, 100B, ATC	3
C5,C12,C18,C30,C31	CAP, 47pF, +/-5%, 0603, ATC	5
C7,C14,C20	CAP, 33000PF, 0805, 100V, X7R	2
J2,J3	CONN, SMA, PANEL MOUNT JACK, FLANGE	2
J1	HEADER RT>PLZ .1CEN LK 5POS	1
Q1	CGH35060F1	1

## CGH35060F1-TB Demonstration Amplifier Circuit

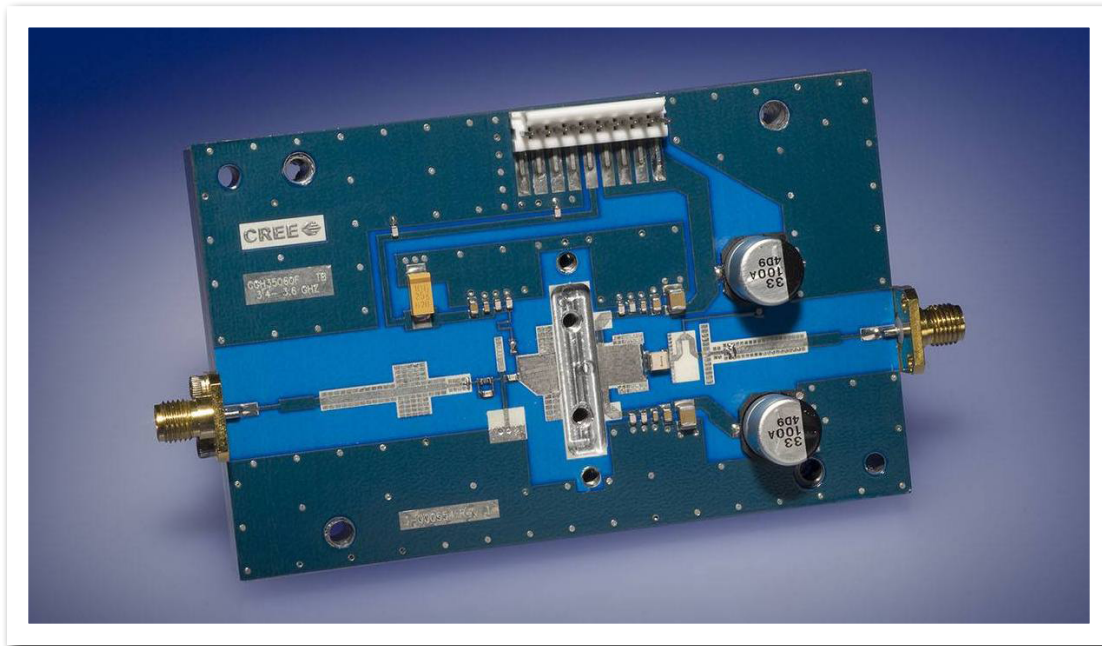

## CGH35060F1-AMP Demonstration Amplifier Circuit Schematic

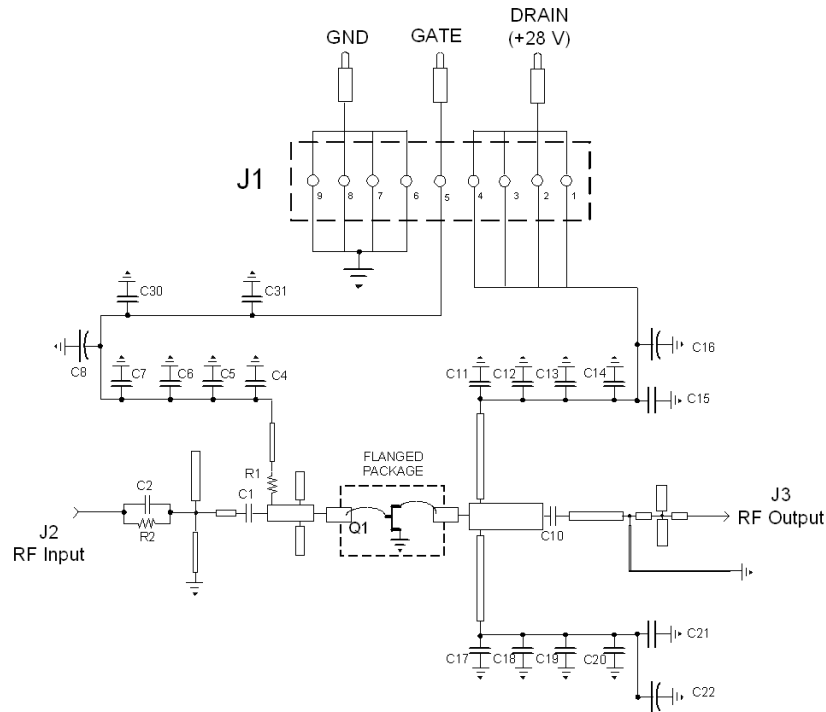

## CGH35060F1-AMP Demonstration Amplifier Circuit Outline

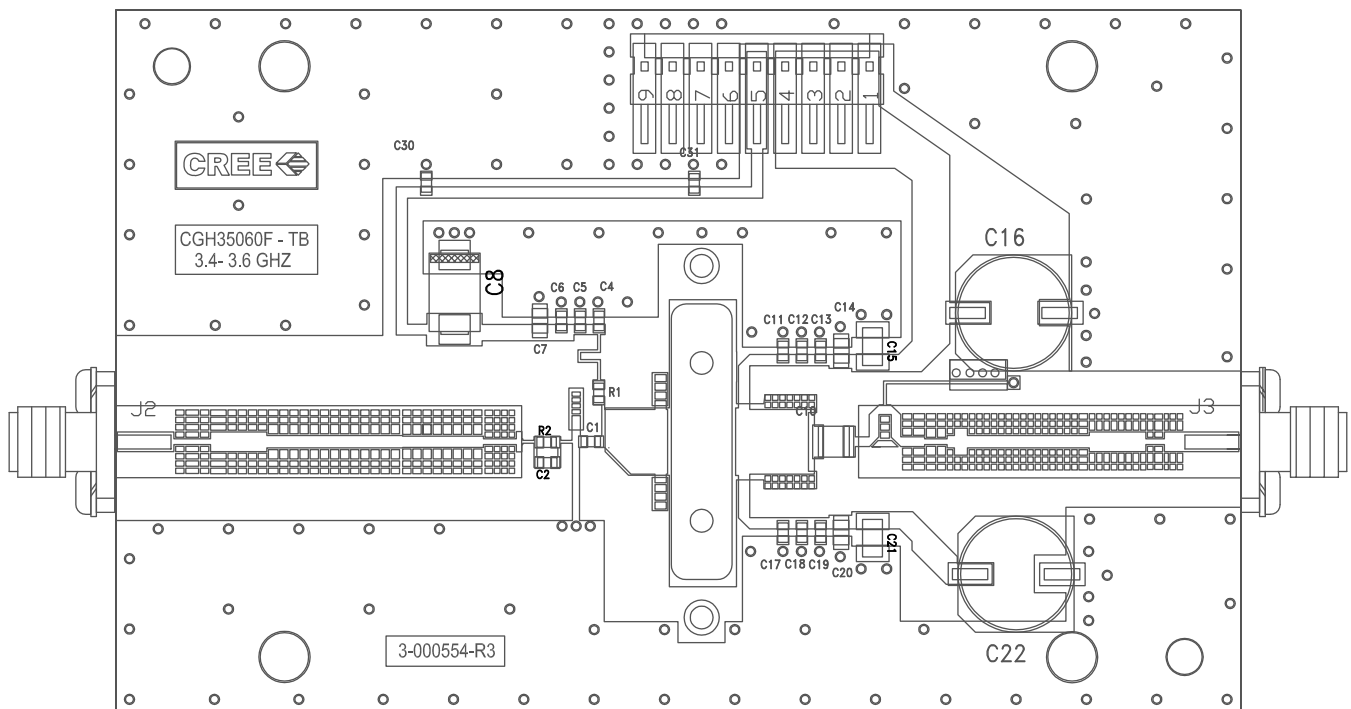



**Typical Package S-Parameters for CGH35060F1/P1**  
 (Small Signal,  $V_{DS} = 28\text{ V}$ ,  $I_{DQ} = 250\text{ mA}$ , angle in degrees)

Frequency	Mag S11	Ang S11	Mag S21	Ang S21	Mag S12	Ang S12	Mag S22	Ang S22
500 MHz	0.932	-170.73	7.26	79.93	0.014	-5.48	0.616	-170.30
600 MHz	0.933	-173.14	6.04	75.95	0.014	-8.53	0.624	-170.60
700 MHz	0.933	-175.02	5.17	72.27	0.014	-11.26	0.632	-170.73
800 MHz	0.934	-176.56	4.51	68.80	0.014	-13.77	0.640	-170.79
900 MHz	0.935	-177.90	3.99	65.50	0.014	-16.12	0.648	-170.84
1.0 GHz	0.936	-179.09	3.58	62.32	0.014	-18.33	0.657	-170.91
1.1 GHz	0.937	179.82	3.24	59.24	0.013	-20.41	0.666	-171.02
1.2 GHz	0.937	178.80	2.96	56.27	0.013	-22.38	0.675	-171.18
1.3 GHz	0.938	177.82	2.73	53.38	0.013	-24.25	0.684	-171.38
1.4 GHz	0.939	176.88	2.53	50.57	0.013	-26.02	0.693	-171.64
1.5 GHz	0.940	175.95	2.35	47.83	0.012	-27.69	0.702	-171.94
1.6 GHz	0.941	175.04	2.20	45.17	0.012	-29.28	0.710	-172.30
1.7 GHz	0.942	174.13	2.07	42.56	0.012	-30.78	0.718	-172.69
1.8 GHz	0.942	173.22	1.96	40.01	0.012	-32.20	0.726	-173.13
1.9 GHz	0.943	172.30	1.86	37.51	0.012	-33.53	0.733	-173.60
2.0 GHz	0.943	171.37	1.77	35.06	0.011	-34.79	0.740	-174.11
2.1 GHz	0.944	170.42	1.69	32.65	0.011	-35.98	0.746	-174.64
2.2 GHz	0.944	169.44	1.62	30.28	0.011	-37.09	0.752	-175.21
2.3 GHz	0.944	168.44	1.56	27.94	0.011	-38.14	0.757	-175.80
2.4 GHz	0.944	167.42	1.51	25.63	0.011	-39.12	0.762	-176.41
2.5 GHz	0.944	166.35	1.47	23.33	0.011	-40.03	0.767	-177.05
2.6 GHz	0.944	165.25	1.43	21.06	0.010	-40.89	0.771	-177.70
2.7 GHz	0.944	164.10	1.39	18.79	0.010	-41.69	0.775	-178.38
2.8 GHz	0.943	162.90	1.36	16.52	0.010	-42.44	0.778	-179.08
2.9 GHz	0.943	161.64	1.34	14.25	0.010	-43.15	0.780	-179.81
3.0 GHz	0.942	160.32	1.32	11.97	0.010	-43.81	0.783	179.45
3.2 GHz	0.939	157.45	1.29	7.34	0.010	-45.03	0.786	177.90
3.4 GHz	0.936	154.21	1.29	2.56	0.010	-46.16	0.787	176.26
3.6 GHz	0.932	150.50	1.30	-2.45	0.010	-47.28	0.786	174.50
3.8 GHz	0.926	146.18	1.32	-7.79	0.010	-48.49	0.783	172.62
4.0 GHz	0.918	141.08	1.37	-13.59	0.011	-49.93	0.778	170.58
4.2 GHz	0.907	134.91	1.45	-20.01	0.011	-51.79	0.770	168.35
4.4 GHz	0.893	127.31	1.55	-27.29	0.012	-54.34	0.759	165.88
4.6 GHz	0.875	117.74	1.68	-35.72	0.013	-57.92	0.745	163.12
4.8 GHz	0.851	105.40	1.85	-45.68	0.014	-62.99	0.726	159.95
5.0 GHz	0.821	89.23	2.06	-57.67	0.016	-70.09	0.701	156.25
5.2 GHz	0.788	67.93	2.29	-72.20	0.018	-79.82	0.668	151.81
5.4 GHz	0.763	40.72	2.50	-89.57	0.019	-92.51	0.624	146.32
5.6 GHz	0.760	8.85	2.62	-109.47	0.021	-107.92	0.563	139.43
5.8 GHz	0.789	-23.42	2.60	-130.80	0.021	-124.97	0.479	130.69
6.0 GHz	0.837	-51.66	2.44	-152.19	0.020	-142.29	0.367	119.31

To download the s-parameters in s2p format, go to the [CGH35060F1/P1 Product Page](#), click on the documentation tab.

## Product Dimensions CGH35060F1 (Package Type – 440193)

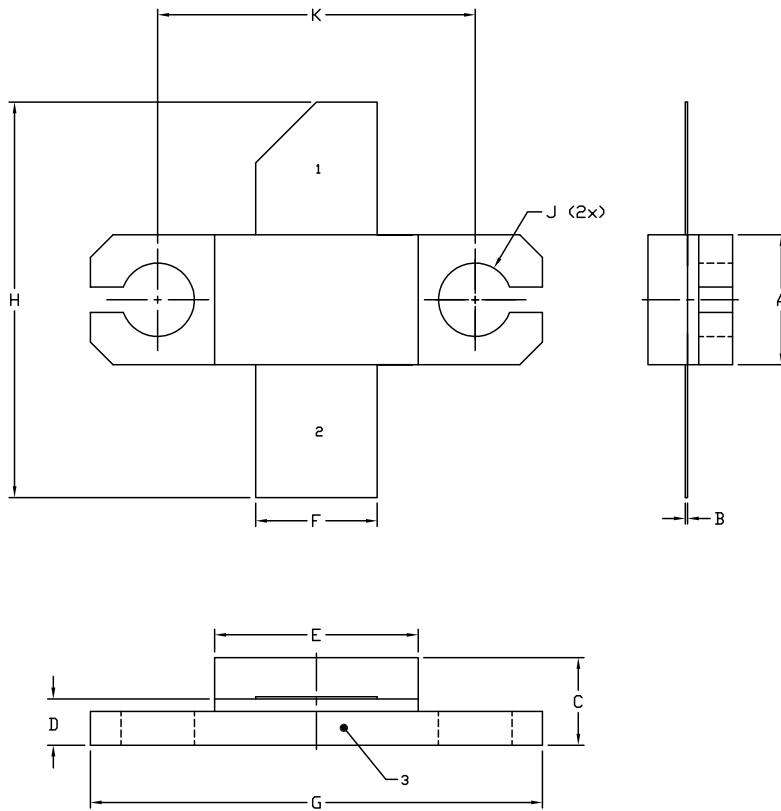

**NOTES:**

1. DIMENSIONING AND TOLERANCING PER ANSI Y14.5M, 1982.
2. CONTROLLING DIMENSION: INCH.
3. ADHESIVE FROM LID MAY EXTEND A MAXIMUM OF 0.020" BEYOND EDGE OF LID.
4. LID MAY BE MISALIGNED TO THE BODY OF THE PACKAGE BY A MAXIMUM OF 0.008" IN ANY DIRECTION.
5. ALL PLATED SURFACES ARE NI/AU

DIM	INCHES		MILLIMETERS	
	MIN	MAX	MIN	MAX
A	0.225	0.235	5.72	5.97
B	0.004	0.006	0.10	0.15
C	0.145	0.165	3.68	4.19
D	0.077	0.087	1.96	2.21
E	0.355	0.365	9.02	9.27
F	0.210	0.220	5.33	5.59
G	0.795	0.805	20.19	20.45
H	0.670	0.730	17.02	18.54
J	∅ .130		3.30	
k		0.562		14.28

- PIN 1. GATE  
 PIN 2. DRAIN  
 PIN 3. SOURCE

## Product Dimensions CGH35060P1 (Package Type – 440196)

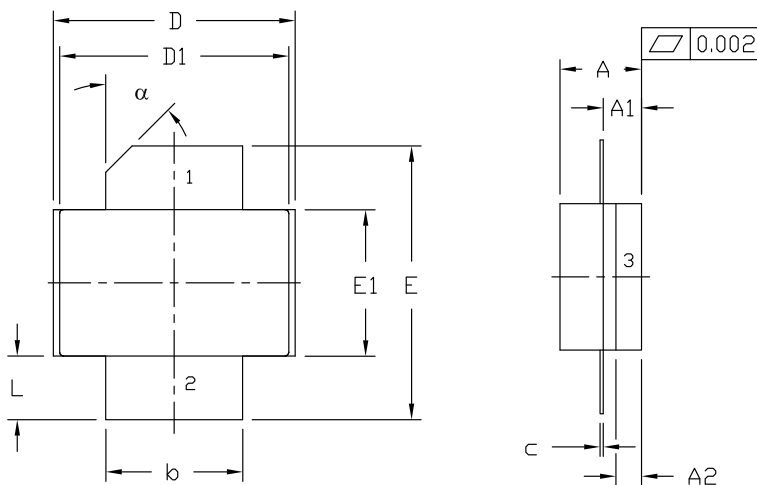

**NOTES:**

1. DIMENSIONING AND TOLERANCING PER ANSI Y14.5M - 1994.
2. CONTROLLING DIMENSION: INCH.
3. ADHESIVE FROM LID MAY EXTEND A MAXIMUM OF 0.020" BEYOND EDGE OF LID.
4. LID MAY BE MISALIGNED TO THE BODY OF PACKAGE BY A MAXIMUM OF 0.008" IN ANY DIRECTION.

DIM	INCHES		MILLIMETERS		NOTES
	MIN	MAX	MIN	MAX	
A	0.125	0.145	3.18	3.68	
A1	0.057	0.067	1.45	1.70	
A2	0.035	0.045	0.89	1.14	
b	0.210	0.220	5.33	5.59	2x
c	0.004	0.006	0.10	0.15	2x
D	0.375	0.385	9.53	9.78	
D1	0.355	0.365	9.02	9.27	
E	0.400	0.460	10.16	11.68	
E1	0.225	0.235	5.72	5.97	
L	0.085	0.115	2.16	2.92	2x
α		45° REF		45° REF	

- PIN 1. GATE  
 PIN 2. DRAIN  
 PIN 3. SOURCE

## Product Ordering Information

Order Number	Description	Unit of Measure	Image
CGH35060F1	GaN HEMT	Each	
CGH35060P1	GaN HEMT	Each	
CGH35060F1-TB	Test board without GaN HEMT	Each	
CGH35060F1-AMP	Test board with GaN HEMT installed	Each	



## Disclaimer

Specifications are subject to change without notice. Cree, Inc. believes the information contained within this data sheet to be accurate and reliable. However, no responsibility is assumed by Cree for any infringement of patents or other rights of third parties which may result from its use. No license is granted by implication or otherwise under any patent or patent rights of Cree. Cree makes no warranty, representation or guarantee regarding the suitability of its products for any particular purpose. "Typical" parameters are the average values expected by Cree in large quantities and are provided for information purposes only. These values can and do vary in different applications and actual performance can vary over time. All operating parameters should be validated by customer's technical experts for each application. Cree products are not designed, intended or authorized for use as components in applications intended for surgical implant into the body or to support or sustain life, in applications in which the failure of the Cree product could result in personal injury or death or in applications for planning, construction, maintenance or direct operation of a nuclear facility.

For more information, please contact:

Cree, Inc.  
4600 Silicon Drive  
Durham, North Carolina, USA 27703  
[www.cree.com/RF](http://www.cree.com/RF)

Sarah Miller  
Marketing & Export  
Cree, RF Components  
919.407.5302

Ryan Baker  
Marketing  
Cree, RF Components  
919.407.7816

Tom Dekker  
Sales Director  
Cree, RF Components  
919.407.5639