

SMD ■ MID Power LED

67-22S/KK7E-HXXXX30Z6/2T(LDV)



Features

- PLCC-2 package
- Top view white LED
- High luminous intensity output
- Wide viewing angle
- Pb-free
- ANSI Binning
- The product itself will remain within RoHS compliant version.
- Compliance with EU REACH.
- Compliance Halogen Free .(Br<900ppm,Cl<900ppm,Br+Cl<1500ppm)

Description

The Everlight 67-22S package has high efficacy, high CRI, low power consumption, wide viewing angle and a compact form factor. These features make this package an ideal LED for all lighting applications.

Applications

- General lighting
- Decorative and Entertainment Lighting
- Indicators
- Illumination
- Switch lights

Product Number Explanation

67-22S / K K 7 E – H XX XX XX Z6 / 2T

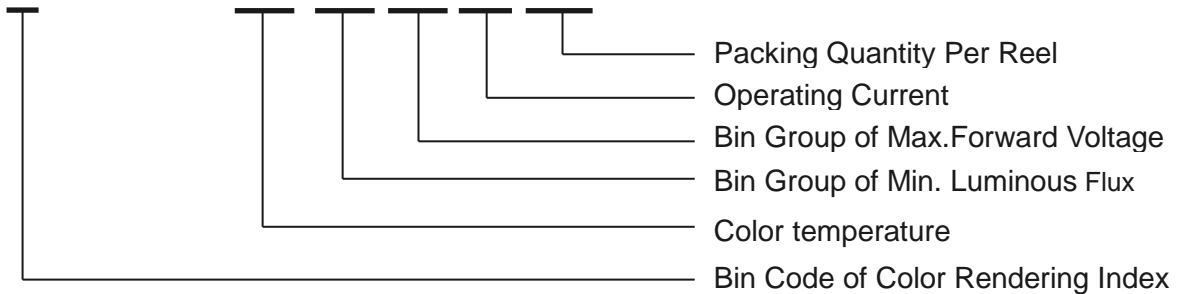

Table of Color Rendering Index

Symbol	Description
M	CRI(Min.) : 60
N	CRI(Min.) : 65
L	CRI(Min.) : 70
Q	CRI(Min.) : 75
K	CRI(Min.) : 80
P	CRI(Min.) : 85
H	CRI(Min.) : 90

Note:
Tolerance of Color Rendering Index: ± 2

Table of Forward Current Index

Symbol	Description
Z6	I _F :60mA

Table of Forward Voltage Index

Symbol	Description
30	3.0V max

Example:
67-22S/KK7E-H403330Z6/2T(LDV)

CRI	80(Min.)
CCT	4000K
Flux	33lm min
V _F	3.0V max
I _F	60mA

Mass Production List

Product	CRI Min. (1)	CCT(K)	Φ(lm) Min. (2)
67-22S/KK7E-H403330Z6/2T(LDV)	80	4000K	33
67-22S/KK7E-H653330Z6/2T(LDV)	80	6500K	33

Notes:

1. Tolerance of Color Rendering Index: ± 2
2. Tolerance of Luminous flux: $\pm 11\%$.
3. 33--33.5lm 允收比例為 25%

EVERLIGHT

Device Selection Guide

Chip Materials	Emitted Color	Resin Color
InGaN	Cool White Neutral White Warm White	Water Clear

Absolute Maximum Ratings (T_{Soldering}=25°C)

Parameter	Symbol	Rating	Unit
Forward Current	I _F	200	mA
Peak Forward Current (Duty 1/10 @10ms)	I _{FP}	400	mA
Power Dissipation	P _d	600	mW
Operating Temperature	T _{opr}	-40 ~ +85	°C
Storage Temperature	T _{stg}	-40 ~ +100	°C
Thermal Resistance (Junction / Soldering point)	R _{th J-S}	21	°C/W
Junction Temperature	T _j	115	°C
Soldering Temperature	T _{sol}	Reflow Soldering : 260 °C for 10 sec. Hand Soldering : 350 °C for 3 sec.	

Note:

The products are sensitive to static electricity and must be carefully taken when handling products

Electro-Optical Characteristics (T_{Soldering}=25°C)

Parameter	Symbol	Min.	Typ.	Max.	Unit	Condition
Luminous Flux ₍₁₎	Φ	33	-----	-----	lm	I _F =60mA
Forward Voltage ₍₂₎	V _F	2.7	-----	3.0	V	I _F =60mA
Color Rendering Index ₍₃₎	R _a	80	-----	-----	-----	I _F =60mA
	R ₉	-----	0	-----	-----	I _F =60mA
Viewing Angle	2θ _{1/2}	-----	120	-----	deg	I _F =60mA
Reverse Current	I _R	-----	-----	50	μA	V _R =5V

Notes:

1. Tolerance of Luminous flux: ±11%.
2. Tolerance of Forward Voltage: ±0.1V.
3. Tolerance of Color Rendering Index: ±2

Bin Range of Luminous Flux for 4000K & 6500K

Bin Code	Min.	Max.	Unit	Condition
P33A	33	33.5	lm	I _F =60mA
P33B	33.5	34		
P34T	34	35		
P35T	35	36		
PA	36	40		

Note:

1. Tolerance of Luminous flux: ±11%
2. P33A 產出比例允收 25% , P33B 以上亮度產出比例需 ≥75%.

Bin Range of Forward Voltage

Group	Bin Code	Min.	Max.	Unit	Condition
2730	34	2.7	2.8	V	I _F =60mA
	35	2.8	2.9		
	36	2.9	3.0		

Note:

Tolerance of Forward Voltage: ±0.1V.

The C.I.E. 1931 Chromaticity Diagram

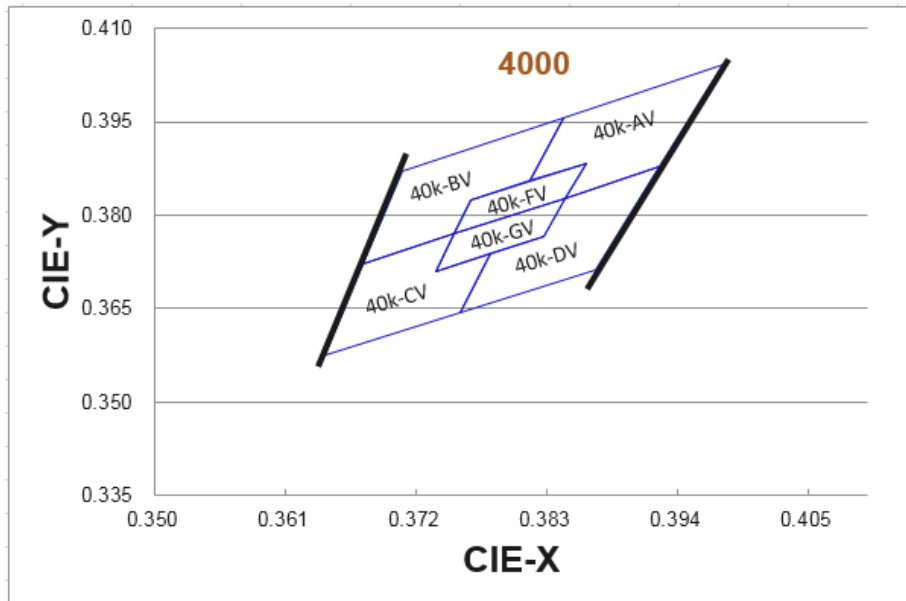

Bin Range of Chromaticity Coordinates

CCT	Bin Code	CIE_x	CIE_y	Bin Code	CIE_x	CIE_y	
4000K	40K-AV	0.3979	0.4041	40K-DV	0.3925	0.3877	
		0.3844	0.3956		0.3846	0.3828	
		0.3816	0.3855		0.3827	0.3765	
		0.3863	0.3884		0.3783	0.3738	
		0.3846	0.3828		0.3757	0.3644	
		0.3925	0.3877		0.3871	0.3713	
	Reference Range:3767K~4028K						
	40K-BV	0.3844	0.3956	40K-CV	0.3676	0.3723	
		0.3709	0.3871		0.3643	0.3575	
		0.3676	0.3723		0.3757	0.3644	
		0.3752	0.3770		0.3783	0.3738	
		0.3766	0.3825		0.3737	0.3710	
		0.3816	0.3855		0.3752	0.3770	
	Reference Range:4028K~4331K						
	40K-FV	0.3863	0.3884	40K-GV	0.3846	0.3828	
		0.3766	0.3825		0.3752	0.3770	
		0.3752	0.3770		0.3737	0.3710	
		0.3846	0.3828		0.3827	0.3765	
	Reference Range:3931K~4145K						

The C.I.E. 1931 Chromaticity Diagram

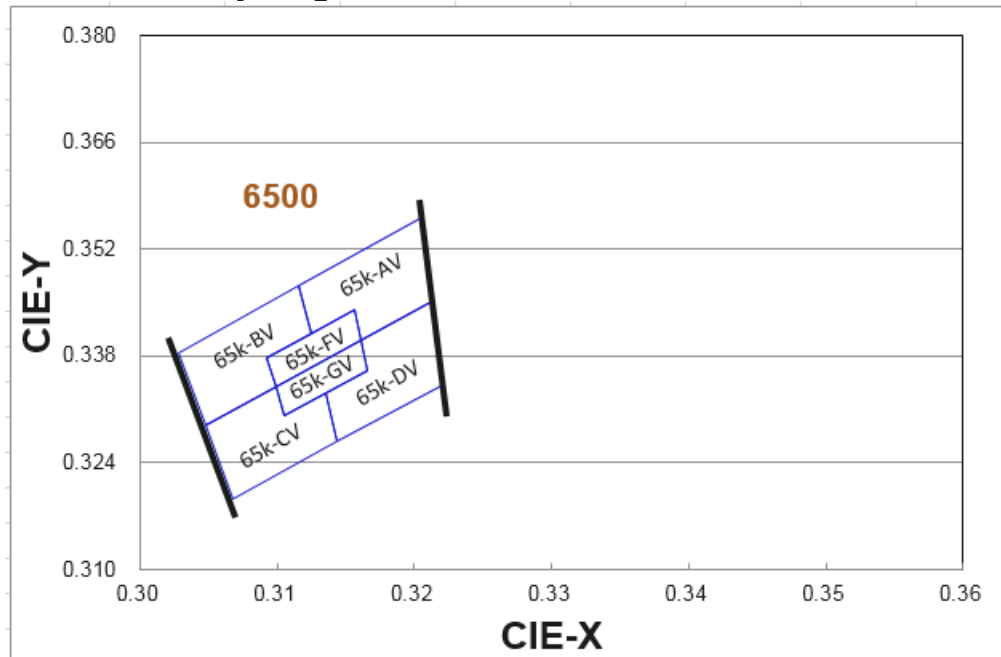

Bin Range of Chromaticity Coordinates

CCT	Bin Code	CIE_x	CIE_y	Bin Code	CIE_x	CIE_y	
6500K	65K-AV	0.3205	0.3561	65K-DV	0.3213	0.3451	
		0.3116	0.3473		0.3161	0.3400	
		0.3125	0.3408		0.3166	0.3361	
		0.3157	0.3440		0.3136	0.3331	
		0.3161	0.3400		0.3144	0.3267	
		0.3213	0.3451		0.3221	0.3341	
	Reference Range:5993K~6434K						
	65K-BV	0.3116	0.3473	65K-CV	0.3048	0.3289	
		0.3028	0.3384		0.3068	0.3193	
		0.3048	0.3289		0.3144	0.3267	
		0.3100	0.3339		0.3136	0.3331	
		0.3093	0.3377		0.3106	0.3302	
		0.3125	0.3408		0.3100	0.3339	
	Reference Range:6434K~6951K						
	65K-FV	0.3157	0.3440	65K-GV	0.3161	0.3400	
		0.3093	0.3377		0.3100	0.3339	
		0.3100	0.3339		0.3106	0.3302	
		0.3161	0.3400		0.3166	0.3361	
	Reference Range:6258K~6616K						

Notes:

1. The value is based on driving current by 60mA.
2. Tolerance of Chromaticity Coordinates: ± 0.01 .

Spectrum Distribution

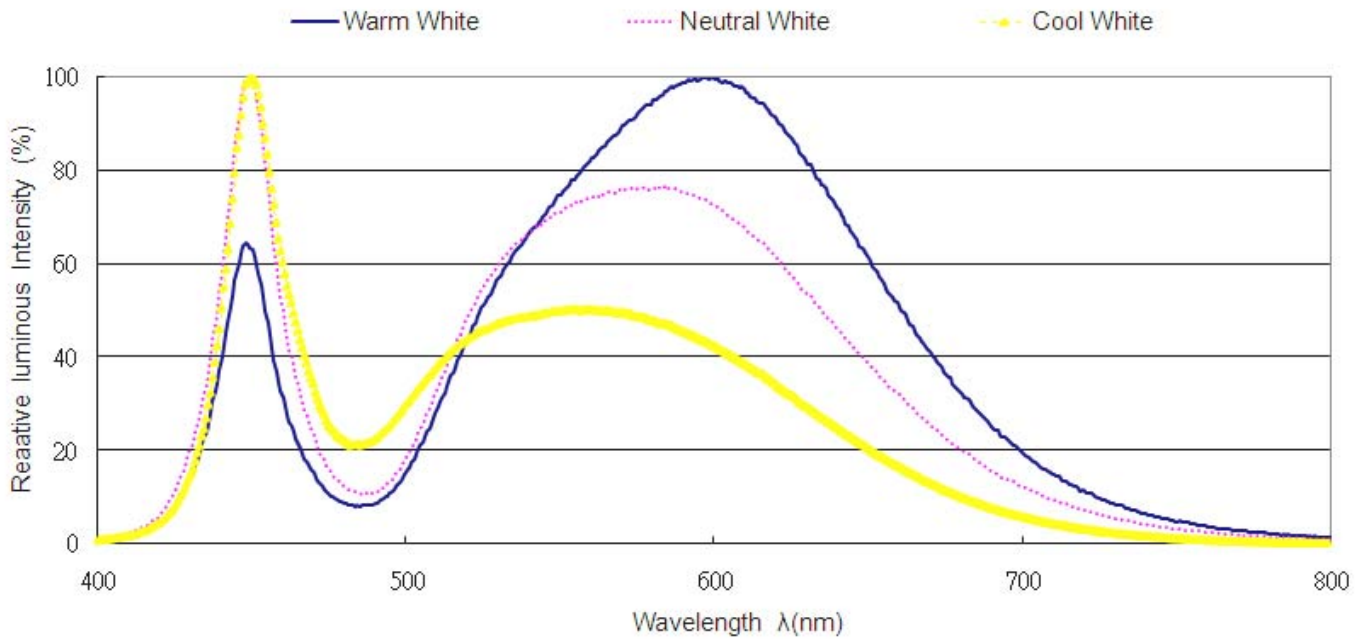

Typical Electro-Optical Characteristics Curves

Fig.1 – Forward Voltage Shift vs. Junction Temperature

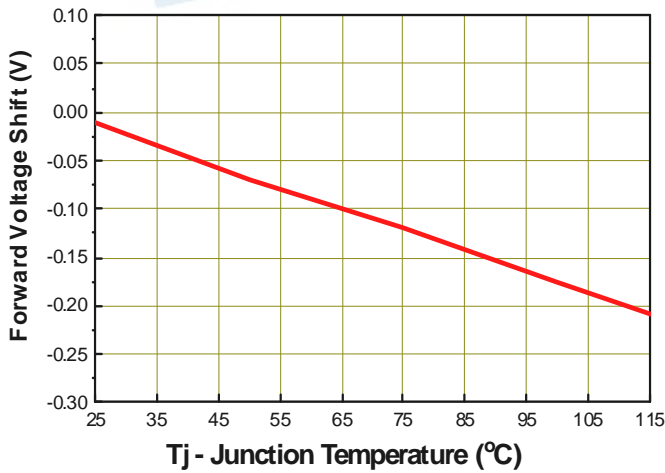
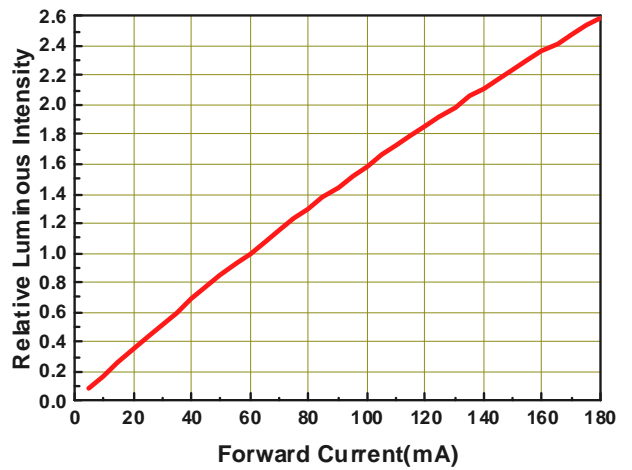

Fig.2 - Relative Luminous Intensity vs. Forward Current



Typical Electro-Optical Characteristics Curves

Fig.3 - Relative Luminous Intensity vs. Junction Temperature

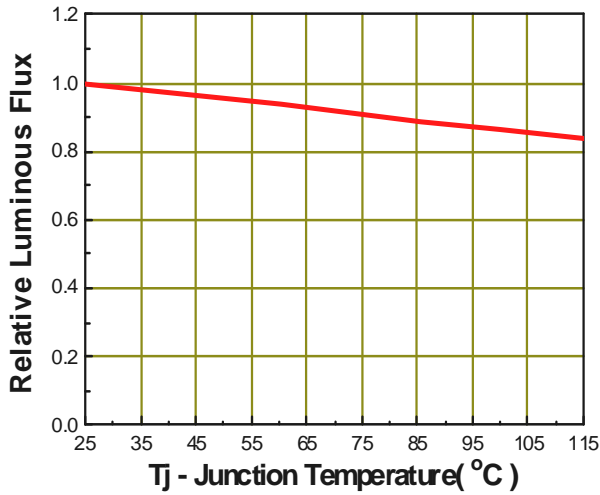

Fig.4 - Forward Current vs. Forward Voltage

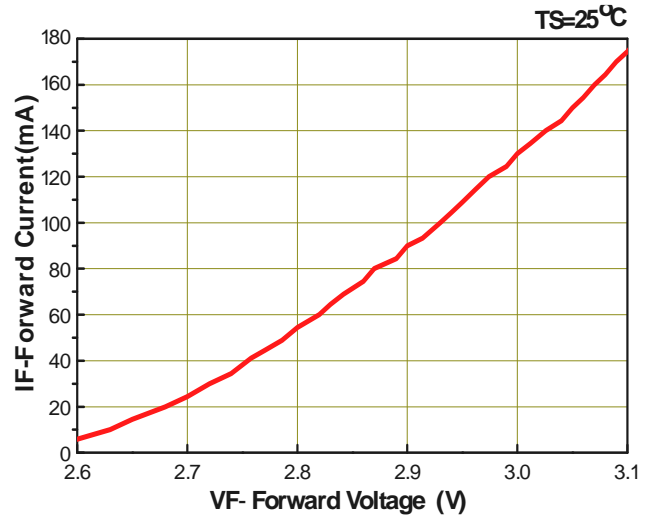

Fig.5 – Max. Driving Forward Current vs. Soldering Temperature

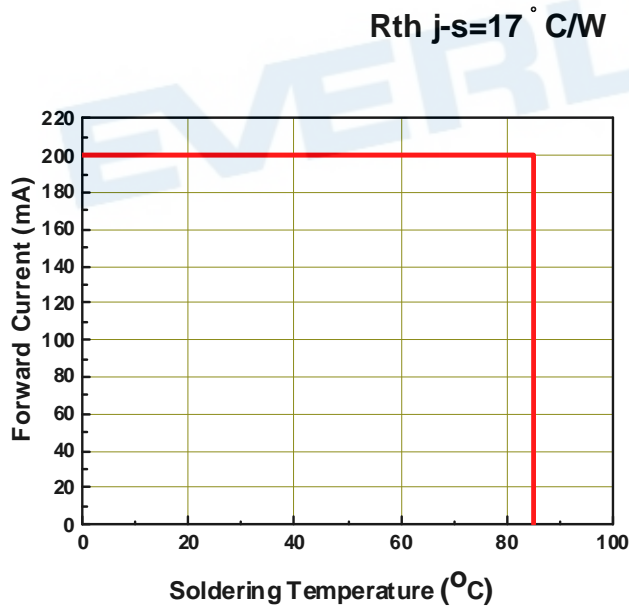
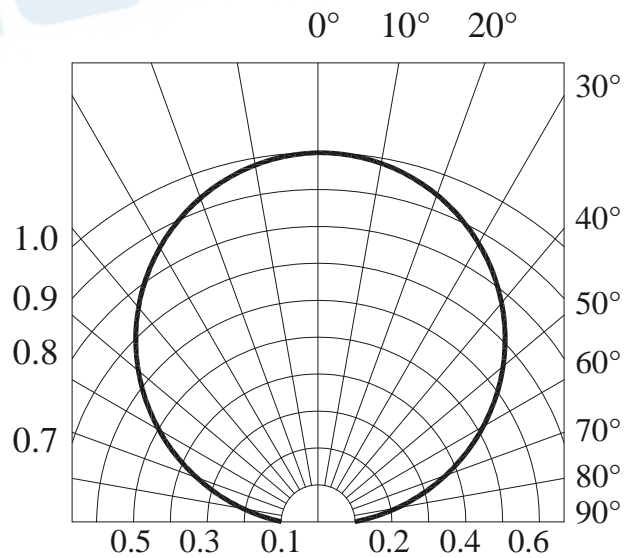
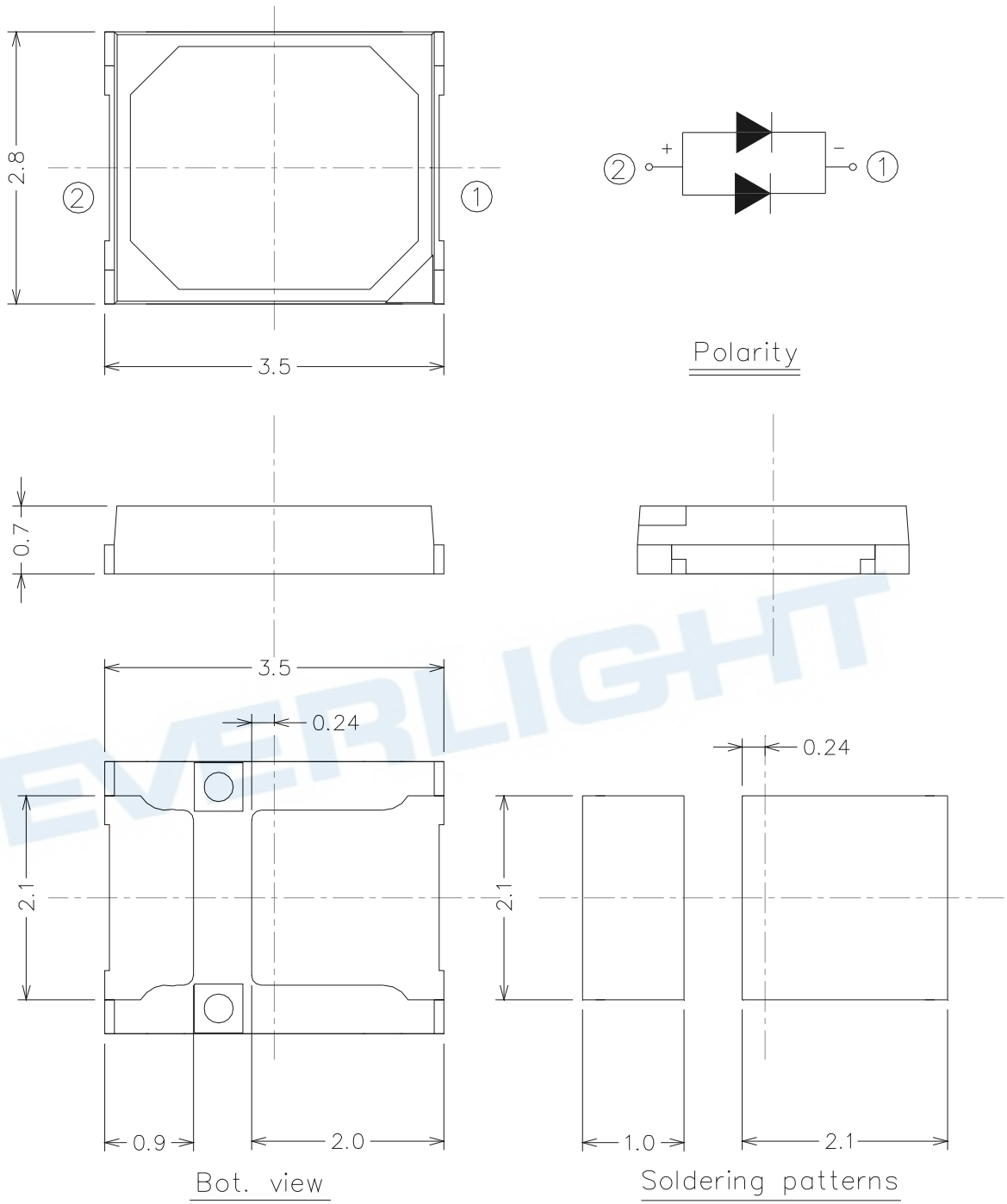

Fig.6 – Radiation Diagram



Package Dimension



Note:
Tolerance unless mentioned is ± 0.15 mm; Unit = mm

Moisture Resistant Packing Materials

Label Explanation

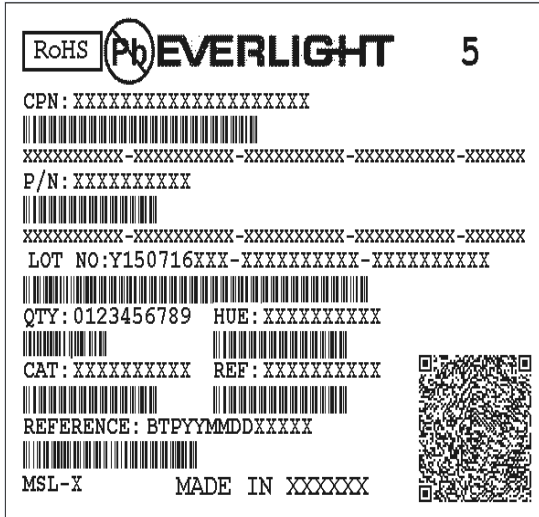

- CPN: Customer's Product Number
- P/N: Product Number
- QTY: Packing Quantity
- CAT: Luminous Intensity Rank
- HUE: Dom. Wavelength Rank
- REF: Forward Voltage Rank
- LOT No: Lot Number

Reel Dimensions

1. Carrier Tape Dimensions:

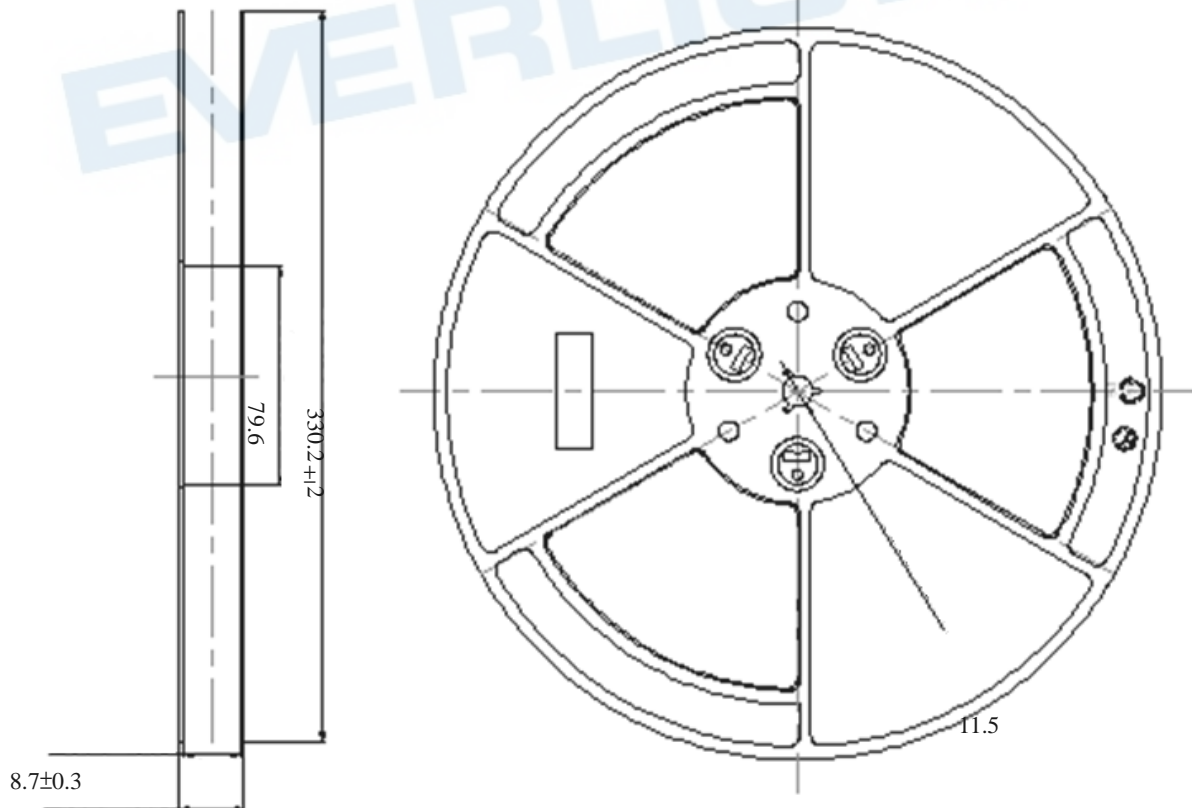

1-1. Loaded Quantity 16000 pcs Per Reel

2.Carrier Tape Dimensions:

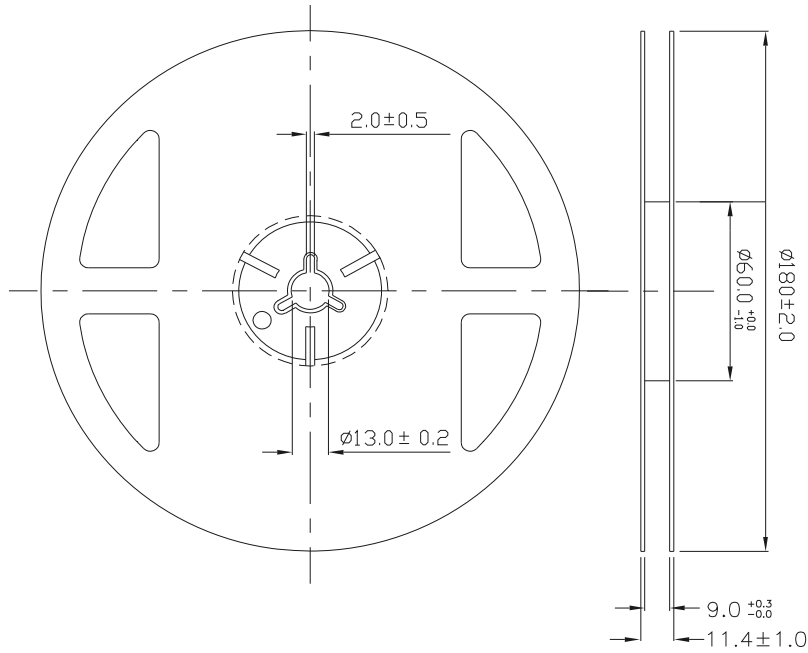

2-1.Loaded Quantity 500/1000/1500/2000/2500/3000/3500/4000 pcs Per Reel

EVERLIGHT

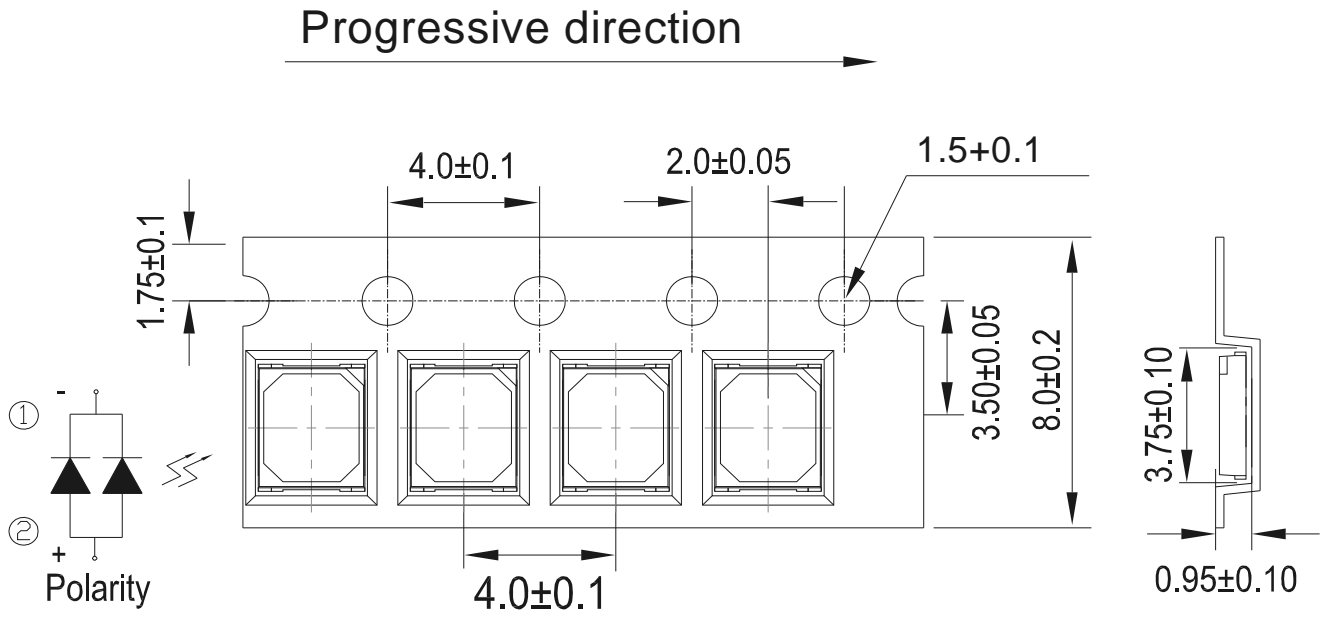

Note:
 1. Tolerance unless mentioned is ± 0.1 mm; Unit = mm

Moisture Resistant Packing Process

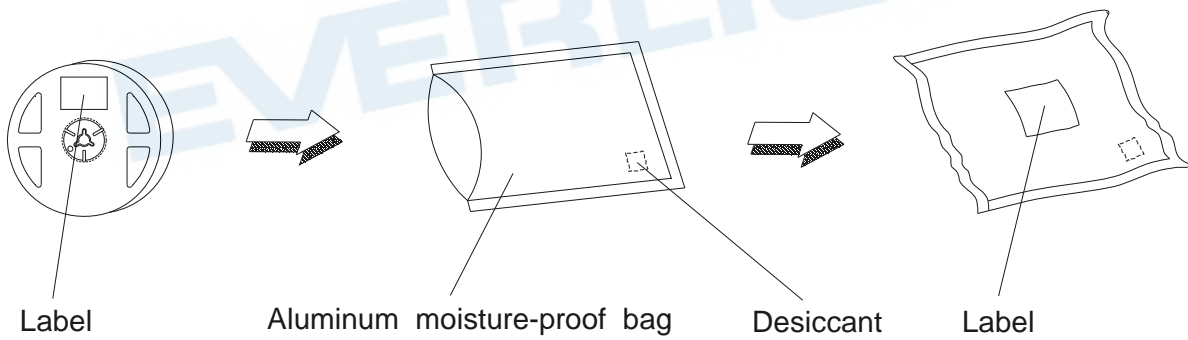

Reliability Test Items and Conditions

The reliability of products shall be satisfied with items listed below.
 Confidence level : 90%
 LTPD : 10%

No.	Items	Test Condition	Test Hours/Cycles	Sample Size	Ac/Re
1	Reflow Soldering	Temp. : 260°C/10sec.	6 Min.	22 PCS.	0/1
2	Thermal Shock	H : +100°C 20min § 10 sec L : -10°C 20min	200 Cycles	22 PCS.	0/1
3	Temperature Cycle	H : +100°C 30min § 5 min L : -40°C 30min	200 Cycles	22 PCS.	0/1
4	High Temperature/Humidity Reverse Bias	Ta=85°C,85%RH	1000 Hrs.	22 PCS.	0/1
5	High Temperature/Humidity Operation	Ta=85°C,85%RH, I _F = 200 mA	1000 Hrs.	22 PCS.	0/1
6	Low Temperature Storage	Ta=-40°C	1000 Hrs.	22 PCS.	0/1
7	High Temperature Storage	Ta=85°C	1000 Hrs.	22 PCS.	0/1
8	Low Temperature Operation Life	Ta=-40°C, I _F = 200 mA	1000 Hrs.	22 PCS.	0/1
9	High Temperature Operation/ Life#1	Ta=25°C, I _F = 200 mA	1000 Hrs.	22 PCS.	0/1
10	High Temperature Operation/ Life#2	Ta=55°C, I _F =200 mA	1000 Hrs.	22 PCS.	0/1
11	High Temperature Operation/ Life#3	Ta=85°C, I _F = 200 mA	1000 Hrs.	22 PCS.	0/1

Precautions for Use

1. Over-current-proof

Customer must apply resistors for protection; otherwise slight voltage shift will cause big current change (Burn out will happen).

2. Storage

2.1 Do not open moisture proof bag before the products are ready to use.

2.2 Before opening the package: The LEDs should be kept at 30°C or less and 90%RH or less.

2.3 After opening the package: The LED's floor life is 168 Hrs under 30°C or less and 60% RH or less. If unused LEDs remain, it should be stored in moisture proof packages.

2.4 If the moisture absorbent material (silica gel) has faded away or the LEDs have exceeded the storage time, baking treatment should be performed using the following conditions.

Baking treatment: 60±5°C for 24 hours.

3. Soldering Condition

3.1 Pb-free solder temperature profile

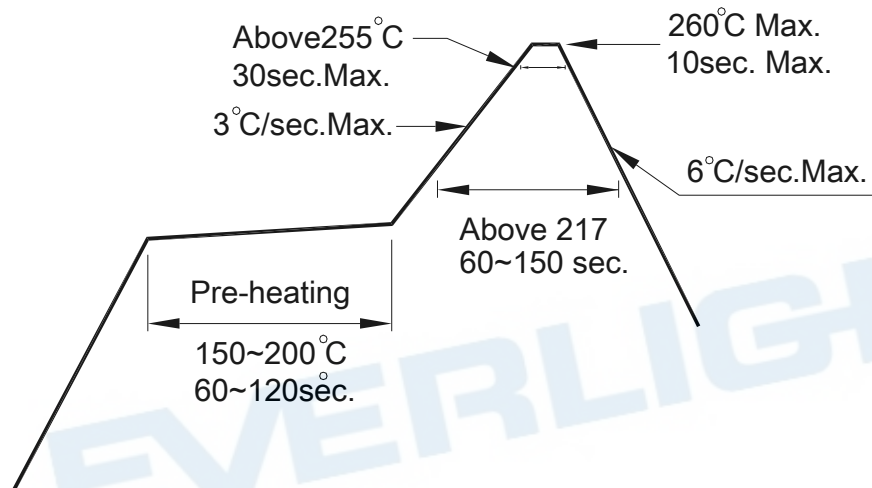

3.2 Reflow soldering should not be done more than two times.

3.3 When soldering, do not put stress on the LEDs during heating.

3.4 After soldering, do not warp the circuit board.

4. Soldering Iron

Each terminal is to go to the tip of soldering iron temperature less than 350°C for 3 seconds within once in less than the soldering iron capacity 25W. Leave two seconds and more intervals, and do soldering of each terminal. Be careful because the damage of the product is often started at the time of the hand solder.

5. Repairing

Repair should not be done after the LEDs have been soldered. When repairing is unavoidable, a double-head soldering iron should be used (as below figure). It should be confirmed beforehand whether the characteristics of the LEDs will or will not be damaged by repairing.

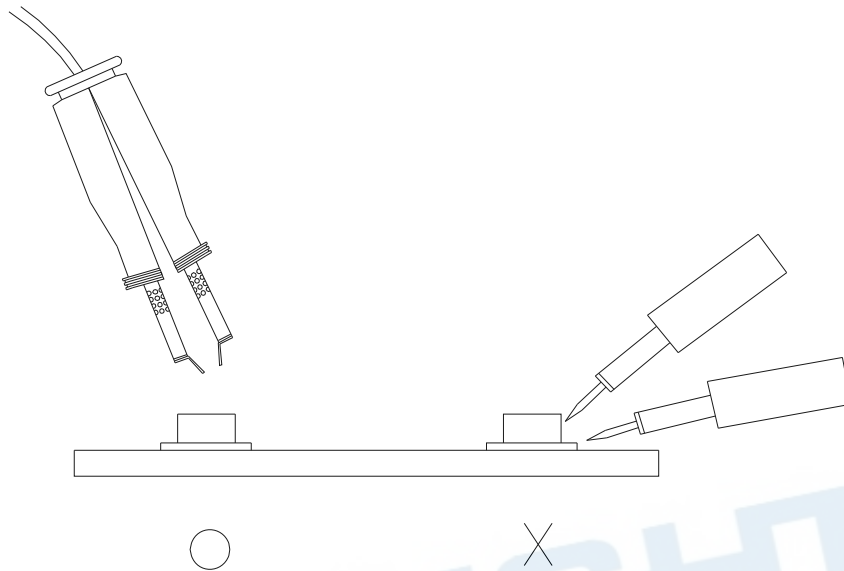

DISCLAIMER

1. EVERLIGHT reserves the right(s) on the adjustment of product material mix for the specification.
2. The product meets EVERLIGHT published specification for a period of twelve (12) months from date of shipment.
3. The graphs shown in this datasheet are representing typical data only and do not show guaranteed values.
4. When using this product, please observe the absolute maximum ratings and the instructions for using outlined in these specification sheets. EVERLIGHT assumes no responsibility for any damage resulting from the use of the product which does not comply with the absolute maximum ratings and the instructions included in these specification sheets.
5. These specification sheets include materials protected under copyright of EVERLIGHT. Reproduction in any form is prohibited without obtaining EVERLIGHT's prior consent.
6. This product is not intended to be used for military, aircraft, automotive, medical,

EVERLIGHT