

# Customer Information Sheet

DRAWING No.: S7251-45R

IF IN DOUBT - ASK

(C)

NOT TO SCALE

THIRD ANGLE PROJECTION

ALL DIMENSIONS IN mm

**NOTES:**

1. QUANTITY PER REEL = 7,000.
2. THIS PRODUCT IS TAPED AND REELED IN GENERAL ACCORDANCE WITH EIA-481-2 (ELECTRONICS INDUSTRIES ASSOCIATION).

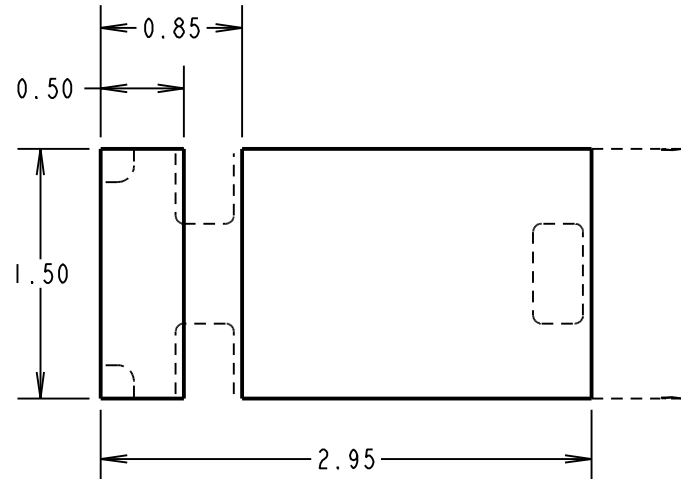

RECOMMENDED PCB LAYOUT  
(TOLERANCE = ±0.05)

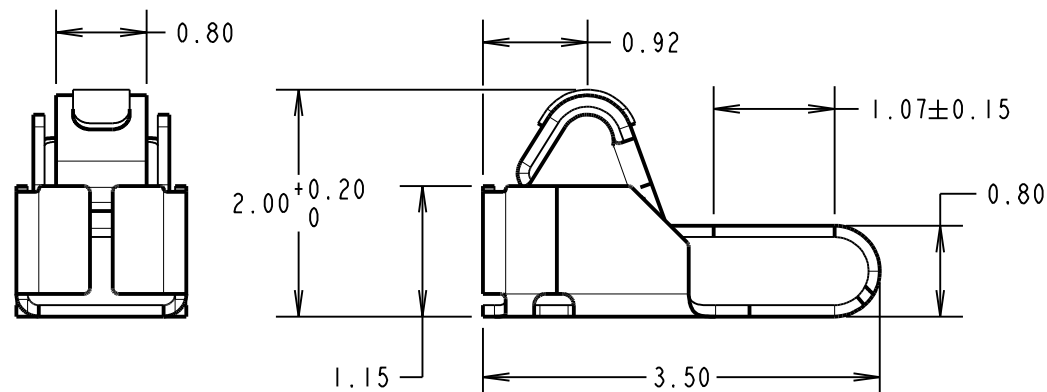
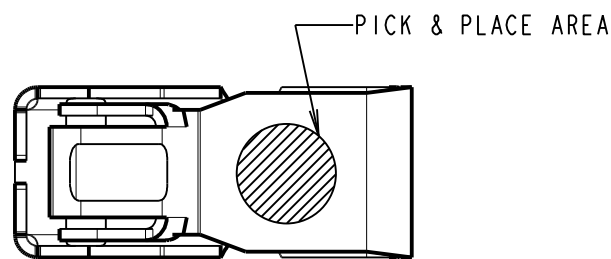
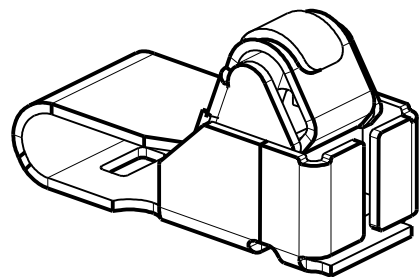

COMPONENT DETAILS

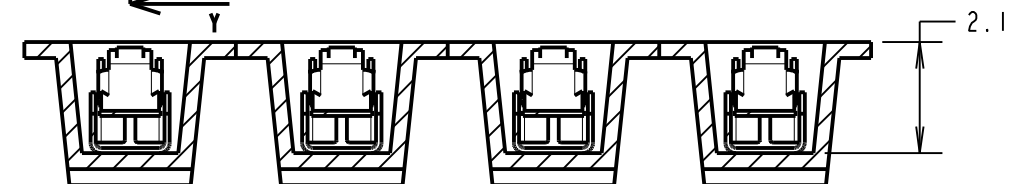
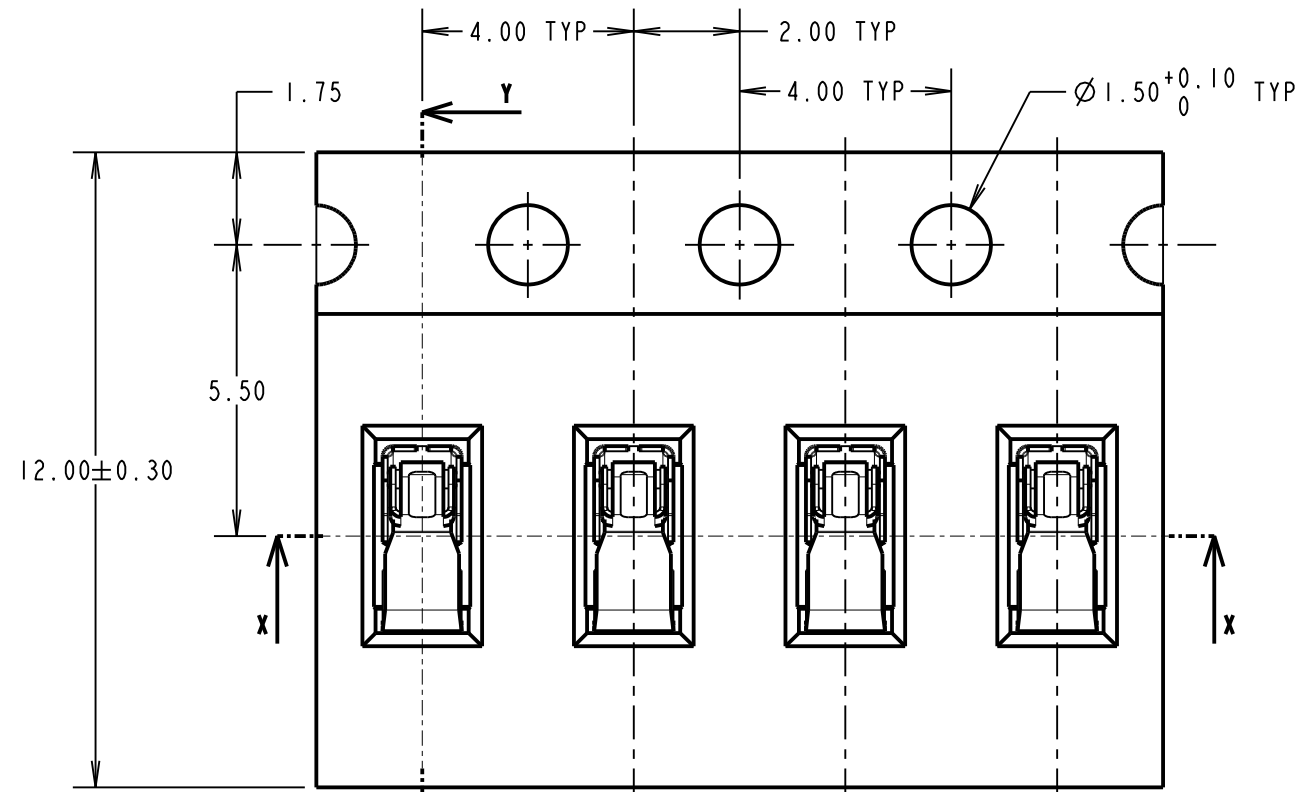
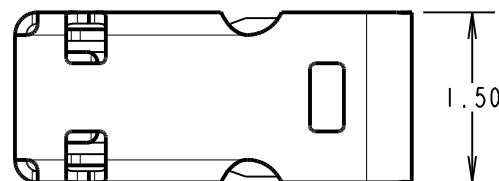

SECTION X-X

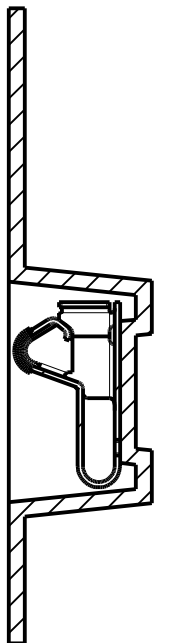

SECTION Y-Y

**SPECIFICATION:**

MATERIAL = TITANIUM COPPER ALLOY, 0.08mm THICK  
 FINISH = 1.5µ-3.5µ NICKEL ALL OVER, 0.1µ GOLD ON TOP  
 CONTACT AREA AND GOLD FLASH ON BASE  
**ELECTRICAL:**  
 CONTACT RESISTANCE = 50mΩ MAX  
 CURRENT RATING = 1A  
 VOLTAGE RATING = 250V AC  
**MECHANICAL:**  
 DURABILITY = 10,000 CYCLES  
 RECOMMENDED WORKING HEIGHT = 1.70mm / MIN FORCE = 0.39N  
 RECOMMENDED MINIMUM WORKING HEIGHT = 1.40mm  
**ENVIRONMENTAL:**  
 OPERATING TEMPERATURE = -40°C TO +85°C

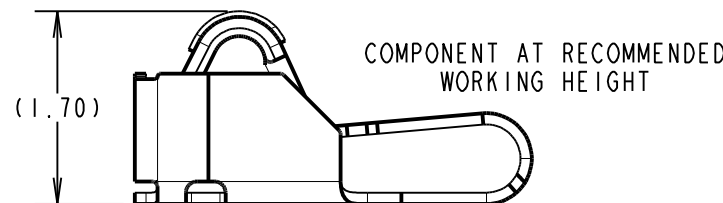

COMPONENT AT RECOMMENDED WORKING HEIGHT

**REEL DETAILS**

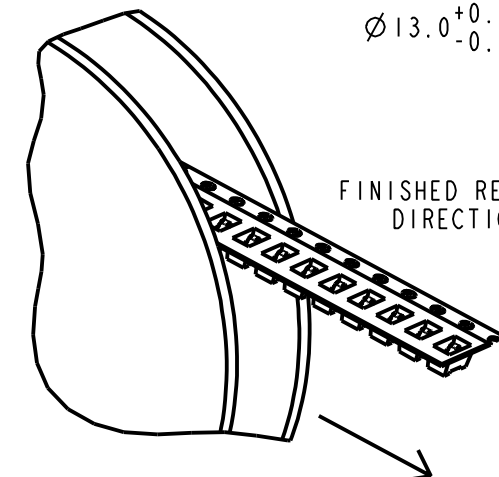
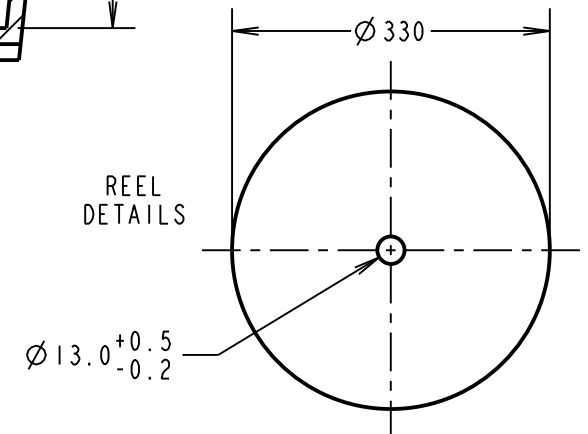

FINISHED REELING DIRECTION

MSP	2	30.11.15	13179
NAME	ISS.	DATE	C/NOTE
APPROVED:		M. PERREN	
CHECKED:		S. BENNETT	
DRAWN:		S. BENNETT	
CUSTOMER REF.:			
ASSEMBLY DRG:			

**HARWIN**

www.harwin.com  
technical@harwin.com

THIS DRAWING AND ANY INFORMATION OR DESCRIPTIVE MATTER SET OUT HEREON ARE CONFIDENTIAL AND COPYRIGHT PROPERTY OF THE HARWIN GROUP AND MUST NOT BE DISCLOSED, LOANED, COPIED OR USED FOR MANUFACTURING, TENDERING OR FOR ANY OTHER PURPOSE WITHOUT THEIR WRITTEN PERMISSION.

**TOLERANCES**  
 X. = ±1mm  
 X.X = ±0.50mm  
 X.XX = ±0.10mm  
 X.XXX = ±0.01mm  
 ANGLES = ±5°  
 UNLESS STATED

**MATERIAL:**  
 SEE ABOVE  
**FINISH:** SEE ABOVE  
**S/AREA:** mm<sup>2</sup>

**TITLE:** SMT SPRING CONTACT  
(1.50mm HIGH)  
IN TAPE AND REEL

**DRAWING NUMBER:** S7271-45R

SHT 2 OF 2