

Parts Drawing

REVISIONS

SYM	ECN No.	MODIFICATION	DATE	ISSUED

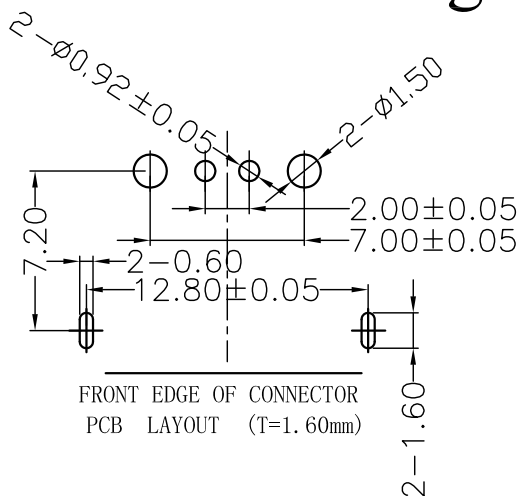
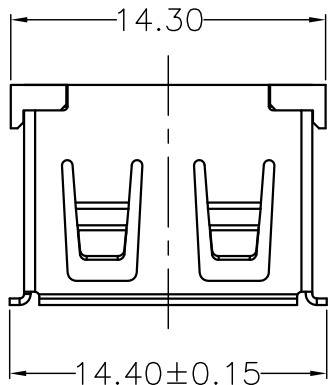

FRONT EDGE OF CONNECTOR
PCB LAYOUT (T=1.60mm)

Note:

1.Material:

- 1.1,Housing: High temperature thermoplastic with/black g.f,UL94v-0
- 1.2,Contact: copper alloy,t=0.25mm
- 1.3,Shell: copper/Ferroalloy alloy,t=0.30mm

2.Specification:

- 2.1,Current rating:1.5A Max.
- 2.2,Dielectric withstanding voltage: 100 V(ac) for 1 min.
- 2.3,Contact resistance: 30 mΩ Max.
- 2.4,Insulation resistance: 100 MΩ Min.
- 2.5,Total mating force: 3.57 Kg Max.
- 2.6,Total unmating force: 1.0 Kg Min.

3.Finish:

- 3.1,Contact: Plated Golt in Mating Area:
Tin On Solder Talls
Shell: Nickel Plating

4.Environmental:

- 4.1,Temperature range: -55°C~85°C

PART ON:

918-15XAXXXDXXX

- 电镀规格: 11, 镀金1u" 13, 镀金3u" 15, 镀金15u" 16, 镀金30u"
- 端子材质: 1, 青铜 2, 磷铜
- 端子规格: D, 90度 Y, 180度 S, SMT贴板
- 塑胶形态: 2, 6.5有耳 7, 6.5无耳
- 塑胶颜色: 01, 白色 02, 黑色 03, 本色
- 塑胶材质: 1, PBT 2, LCP 3, PA9T 4, PPA 5, PA6T
- 对插方向: A, 正向 B, 反向
- 外壳材质: 1, 铁壳 2, 铜壳
- 插口类型: 5, 有边 6, 无边
- 外壳脚型: 1, 前两脚 2, 后两脚 3, 四脚 4, 无脚
- 类别: 大电流系列

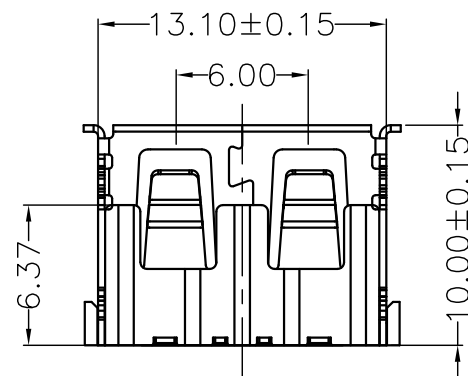
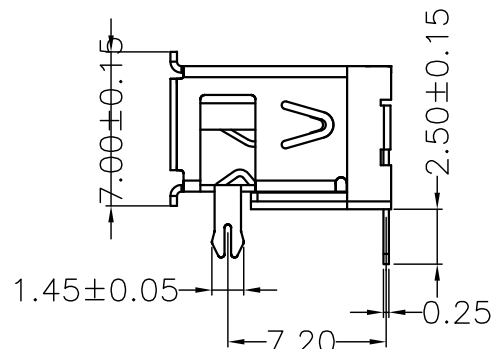
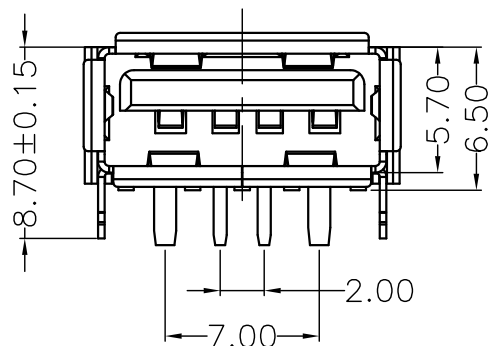

1	919-152A1092D10200	1	
2		2	
3		3	
4		4	

DRAWN

jt 深圳市精拓金电子有限公司

CHECKED

TITLE
AF10.0D款大电流前两脚
有边铜壳PBT绿胶DIP-H6.5

PART NO.

919-152A1092D10200

APPROVED

DRAWING NO.

R918151A1012D211

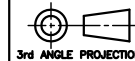

UNIT
mm

TOLERANCE
.XXX±.10, .XX±.25, .X±.38, ANG±5°

SCALE
1:1

SHEET
1 OF 1

SIZE
A4

REV.
X1