

HF3000C-TMA Series (RoHS Compliant)

3-phase 3-line 460VAC

For EMC Directive EN55011, EN55022 (Class A, B)
Standard of High attenuation EMI Filter



EN60939-2 (file No.R50031226)

Applications

IGBT Inverter, ACServo, NC Machinery

Specifications

Part No.	Rated Current	Weight	Dimensions [mm]												
			A	B	C	D	E	F	G	H	J	K	L	M	N
HF3005C-TMA	5A	2Kg	180	140	90	170	155	140	32	130	65	R2.75 L7	M4	M4	fig1
HF3010C-TMA	10A	2Kg	180	140	90	170	155	140	32	130	65		M4	M4	
HF3015C-TMA	15A	2Kg	180	140	90	170	155	140	32	130	65		M4	M4	
HF3020C-TMA	20A	2Kg	180	140	90	170	155	140	32	130	65		M4	M4	
HF3030C-TMA	30A	3.2Kg	260	210	85	155	140	125	44	140	70	R3.24 L8	M5	M4	fig2
HF3040C-TMA	40A	5.5Kg	260	210	85	155	140	125	44	140	70		M5	M4	
HF3050C-TMA	50A	6.7Kg	290	240	100	190	175	160	44	170	100		M6	M4	
HF3060C-TMA	60A	10Kg	290	240	100	190	175	160	44	230	160	R4.25 L12	M6	M4	fig3
HF3080C-TMA	80A	13Kg	405	350	100	220	200	180	56	210	135		M8	M6	
HF3100C-TMA	100A	14.5Kg	405	350	100	220	200	180	56	210	135	100	M8	M6	fig4
HF3150C-TMA	150A	23Kg	570	550	530	230	190	100	15	210	134		M10	M8	
HF3200C-TMA	200A	23.5Kg	570	550	530	230	190	100	15	210	134	150	M10	M8	fig5
HF3250C-TMA	250A	35Kg	670	650	630	280	240	150	20	260	187		M10	M8	
HF3300C-TMA	300A	35Kg	670	650	630	280	240	150	20	260	187	150	M10	M8	40
Rated Voltage	460VAC max														
Leakage Current	5.3mA max / 460VAC 60Hz														

fig.1 (5-20A)

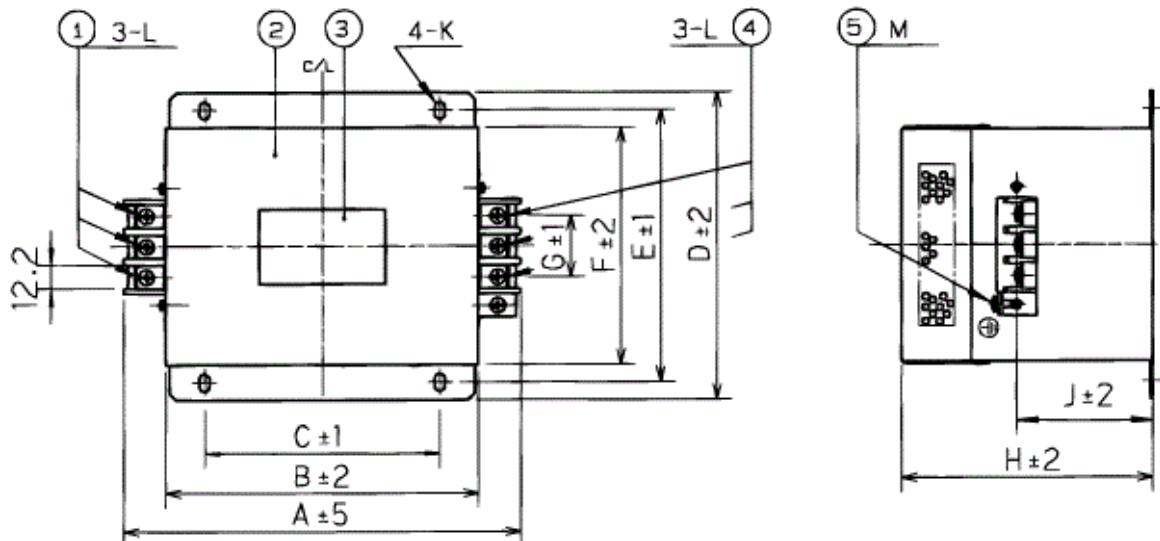

fig.2 (30-60A)

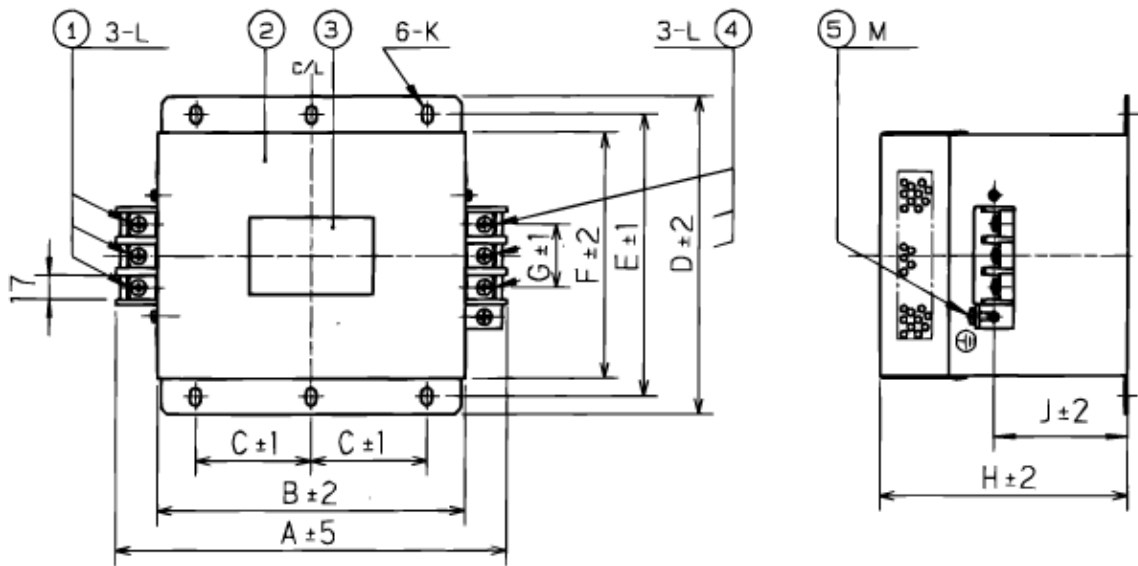

fig. 3 (80, 100A)

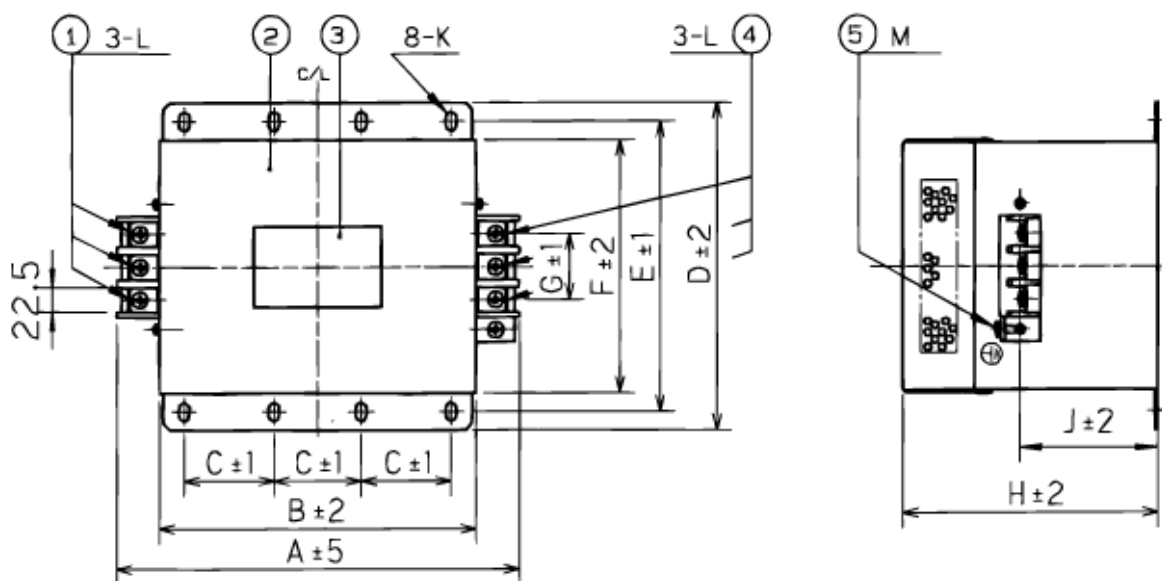

fig. 4 (150, 200A)

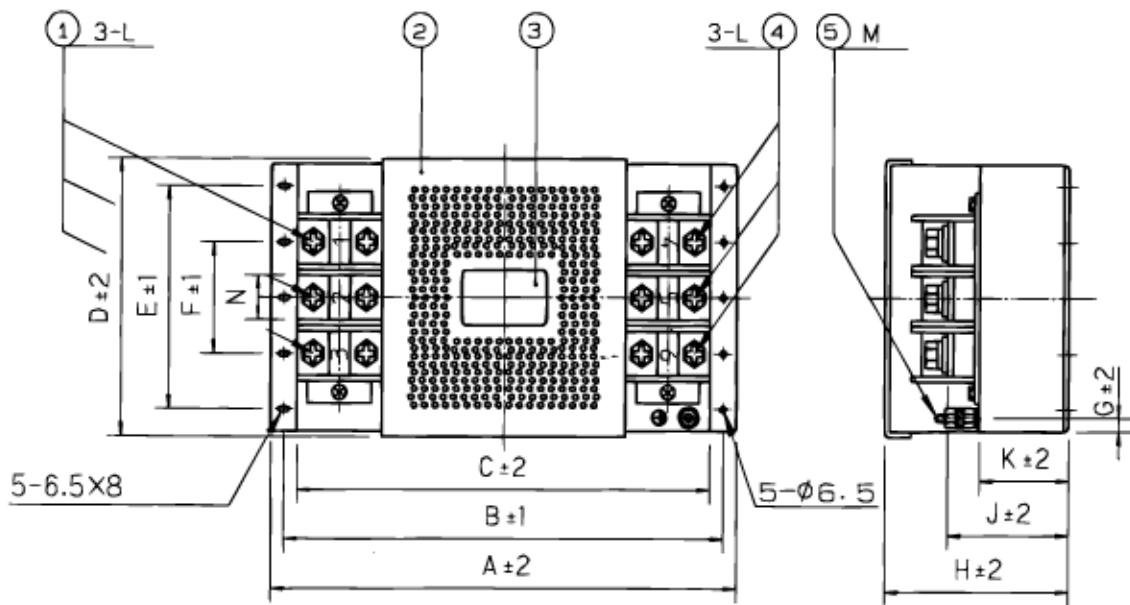
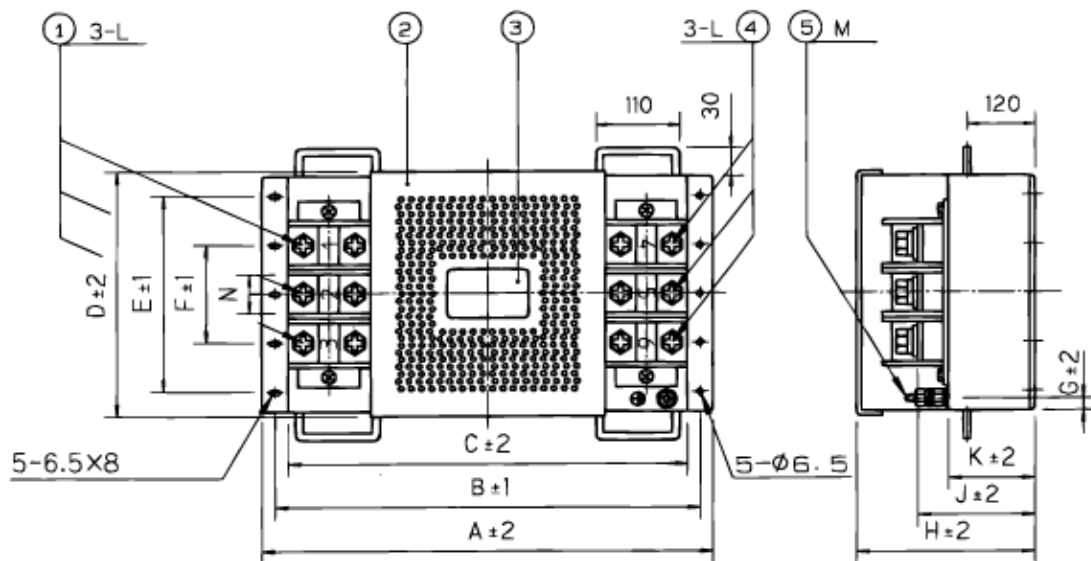
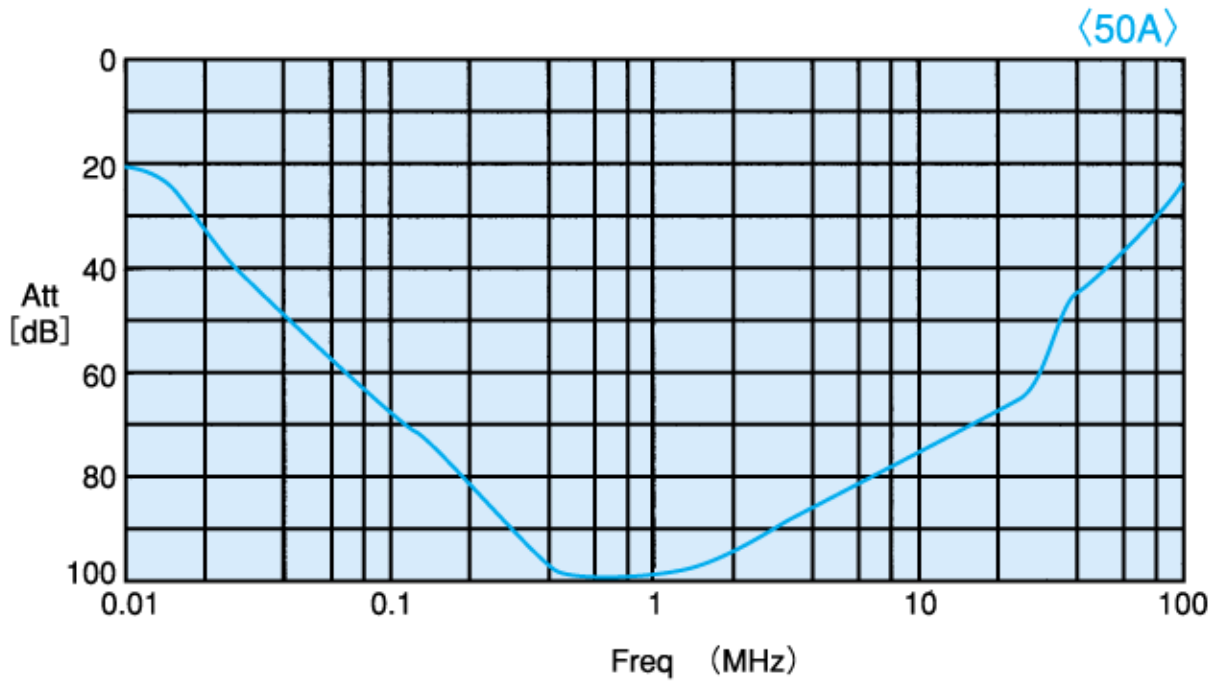

fig. 5 (250, 300A)



Characteristics (Typical)



Circuit Diagram

