

PLEASE CHECK WWW.MOLEX.COM FOR LATEST PART INFORMATION

Part Number: [0190710306](#)
Status: **Active**
Description: InsulKrimp™ Ring Tongue Terminal for 1/0 AWG Wire

Documents:

[Drawing \(PDF\)](#) [RoHS Certificate of Compliance \(PDF\)](#)
[Product Specification PS-19902-009 \(PDF\)](#)

General

Product Family	Ring and Spade Terminals
Series	19071
Crimp Quality Equipment	Yes
Mil-Spec	N/A
Product Name	InsulKrimp™
Type	Ring

Physical

Barrel Type	Closed
Color - Resin	Natural
Insulation	PVC
Material - Plating Mating	Tin
Packaging Type	Bag
Stud Size	5/16" (M8)
Wire Insulation Diameter	17.50mm (.690") max.
Wire Size AWG	1

Material Info

Old Part Number	H-681-56X
-----------------	-----------

Reference - Drawing Numbers

Product Specification	PS-19902-009
Sales Drawing	SD-19071-006

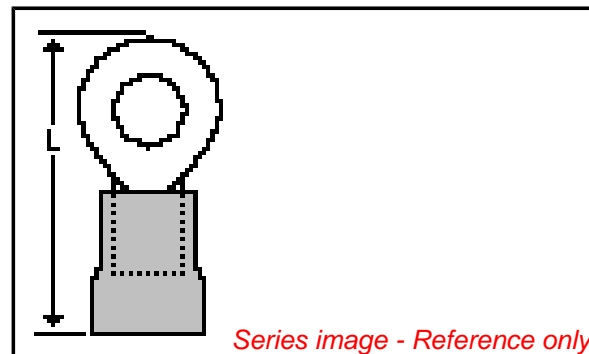

EU RoHS

ELV and RoHS Compliant
REACH SVHC
 Not Reviewed
Halogen-Free Status
 Not Reviewed

China RoHS



Need more information on product environmental compliance?

Email productcompliance@molex.com
 For a multiple part number RoHS Certificate of Compliance, [click here](#)

Please visit the [Contact Us](#) section for any non-product compliance questions.

Search Parts in this Series

[19071Series](#)

Application Tooling | [FAQ](#)

Tooling specifications and manuals are found by selecting the products below. Crimp Height Specifications are then contained in the Application Tooling Specification document.

Global

Description	Product #
Manual Putt Pump Hydraulic System, Die set required	0192860117
Putt Pump Dieless Head System	0192860065

MATERIAL: Copper
 PLATING: Electro-Tin (.0003 Min.)
 INSULATION: PVC, Color Coded Blue
 STUD SIZES: ("D" ±.005)

INSULKRIMP X

*Optional Style

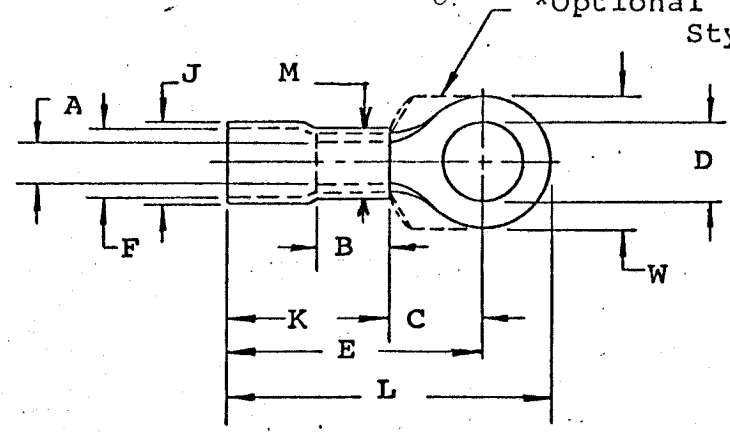

"M" - .740" Maximum

- 14 - .265"
- 56 - .328"
- 38 - .390"
- 76 - .453"
- 12 - .515"
- 58 - .656"
- 34 - .781"
- 78 - .906"

Part Number	"W"	"C" Min.	"E" Max.	"K" Max.	"L"	"A" Min.Avg.	"F" (MWID)	Stock Thickness	"J" Max.	"B" Min.	Available Stud Size
H-680-X*	.894 .870	.740		1.355		.430	.680	.075	.805	.660	14, 56, 38, 76 12
H-681-X	.833 .807	.740	2.235	1.455	2.620	.430	.680	.075	.805	.660	14, 56, 38
H-682-X	1.270 1.244	1.276		1.355		.430	.680	.075	.805	.660	38, 12, 58, 34 78

NOTE: (MWID) denotes maximum wire insulation diameter.



TITLE: CUSTOMER DRAWING
 1/0 WIRE RANGE (H)
 RING TONGUE TERMINAL

DIMENSIONAL TOLERANCE UNLESS OTHERWISE SPECIFIED		
FRAC.	DEC.	ANG.
±	±	±

REVISION	SCALE: _____	DATE
	DRWN. BY: JTK	1-21-70
	CHKD. BY: _____	
	APPRD. BY: _____	
	DRAWING NO.:	