

Features

- Powerful Harvard Architecture Processor
 - M8C Processor Speeds to 24 MHz
 - Low power at high speed
 - 2.4V to 5.25V Operating Voltage
 - Operating Voltages Down to 1.0V using On-Chip Switch Mode Pump (SMP)
 - Industrial Temperature Range: -40°C to +85°C
- Advanced Peripherals (PSoC Blocks)
 - 4 Analog Type "E" PSoC Blocks provide:
 - 2 Comparators with DAC Refs
 - Single or Dual 8-Bit 28 Channel ADC
 - 4 Digital PSoC Blocks provide:
 - 8 to 32-Bit Timers, Counters, and PWMs
 - CRC and PRS Modules
 - Full-Duplex UART, SPI™ Master or Slave
 - Connectable to All GPIO Pins
 - Complex Peripherals by Combining Blocks
- Flexible On-Chip Memory
 - 8K Flash Program Storage 50,000 Erase/Write Cycles
 - 512 Bytes SRAM Data Storage
 - In-System Serial Programming (ISSP™)
 - Partial Flash Updates
 - Flexible Protection Modes
 - EEPROM Emulation in Flash
- Complete Development Tools
 - Free Development Software (PSoC Designer™)
 - Full-Featured, In-Circuit Emulator and Programmer
 - Full Speed Emulation
 - Complex Breakpoint Structure
 - 128K Trace Memory
- Precision, Programmable Clocking
 - Internal ±2.5% 24/48 MHz Oscillator
 - Internal Oscillator for Watchdog and Sleep
- Programmable Pin Configurations
 - 25 mA Drive on All GPIO
 - Pull Up, Pull Down, High Z, Strong, or Open Drain Drive Modes on All GPIO
 - Up to 8 Analog Inputs on GPIO
 - Configurable Interrupt on All GPIO

- Versatile Analog Mux
 - Common Internal Analog Bus
 - Simultaneous Connection of IO Combinations
 - Capacitive Sensing Application Capability
- Additional System Resources
 - I²C™ Master, Slave and Multi-Master to 400 kHz
 - Watchdog and Sleep Timers
 - User-Configurable Low Voltage Detection
 - Integrated Supervisory Circuit
 - On-Chip Precision Voltage Reference

Block Diagram

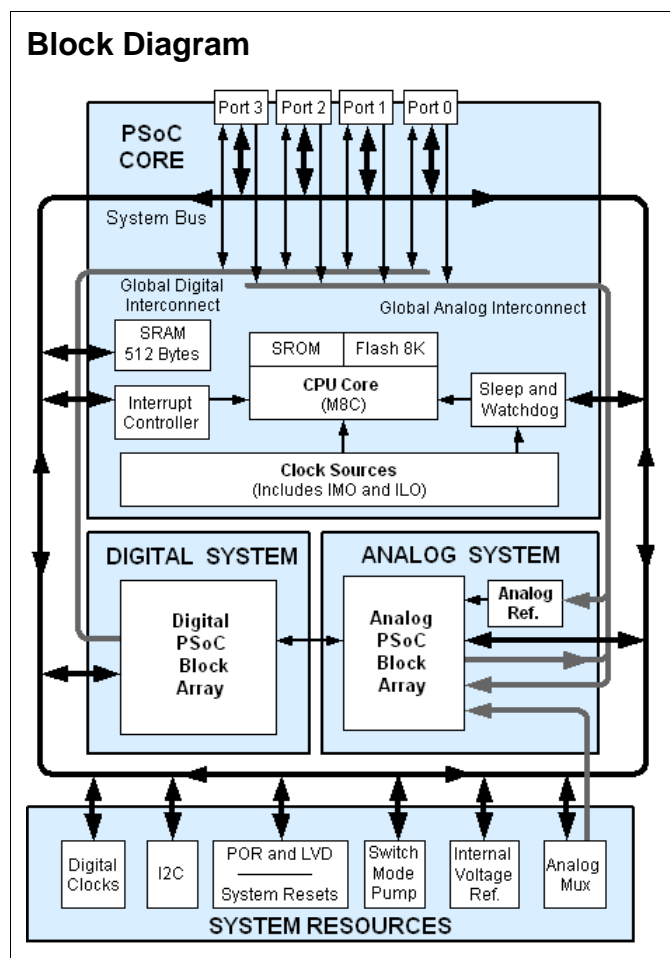

PSoC[®] Functional Overview

The PSoC[®] family consists of many Mixed-Signal Array with On-Chip Controller devices. These devices are designed to replace multiple traditional MCU-based system components with one low cost single-chip programmable component. A PSoC device includes configurable blocks of analog and digital logic, and programmable interconnect. This architecture enables the user to create customized peripheral configurations, to match the requirements of each individual application. Additionally, a fast CPU, Flash program memory, SRAM data memory, and configurable IO are included in a range of convenient pinouts.

The PSoC architecture, shown in Figure 1, consists of four main areas: the Core, the System Resources, the Digital System, and the Analog System. Configurable global bus resources allow combining all the device resources into a complete custom system. Each CY8C21x34 PSoC device includes four digital blocks and four analog blocks. Depending on the PSoC package, up to 28 general purpose IO (GPIO) are also included. The GPIO provide access to the global digital and analog interconnects.

The PSoC Core

The PSoC Core is a powerful engine that supports a rich instruction set. It encompasses SRAM for data storage, an interrupt controller, sleep and watchdog timers, and IMO (internal main oscillator) and ILO (internal low speed oscillator). The CPU core, called the M8C, is a powerful processor with speeds up to 24 MHz. The M8C is a four MIPS 8-bit Harvard architecture microprocessor.

System Resources provide the following additional capabilities:

- Digital clocks to increase the flexibility of the PSoC mixed-signal arrays.
- I2C functionality to implement an I2C master and slave.
- An internal voltage reference, MultiMaster, that provides an absolute value of 1.3V to a number of PSoC subsystems.
- A switch mode pump (SMP) that generates normal operating voltages off a single battery cell.
- Various system resets supported by the M8C.

The Digital System consists of an array of digital PSoC blocks that may be configured into any number of digital peripherals. The digital blocks are connected to the GPIO through a series of global buses that can route any signal to any pin, freeing designs from the constraints of a fixed peripheral controller.

The Analog System consists of four analog PSoC blocks, supporting comparators and analog-to-digital conversion up to 8 bits in precision.

The Digital System

The Digital System consists of 4 digital PSoC blocks. Each block is an 8-bit resource that is used alone or combined with other blocks to form 8, 16, 24, and 32-bit peripherals, which are called user module references. Digital peripheral configurations include the following.

- PWMs (8 to 32 bit)
- PWMs with Dead band (8 to 32 bit)
- Counters (8 to 32 bit)
- Timers (8 to 32 bit)
- UART 8 bit with selectable parity
- SPI master and slave
- I2C slave and multi-master
- Cyclical Redundancy Checker/Generator (8 to 32 bit)
- IrDA
- Pseudo Random Sequence Generators (8 to 32 bit)

The digital blocks are connected to any GPIO through a series of global buses that can route any signal to any pin. The buses also allow for signal multiplexing and for performing logic operations. This configurability frees your designs from the constraints of a fixed peripheral controller.

Digital blocks are provided in rows of four, where the number of blocks varies by PSoC device family. This allows the optimum choice of system resources for your application. Family resources are shown in Table 1 on page 4.

Figure 1. Digital System Block Diagram

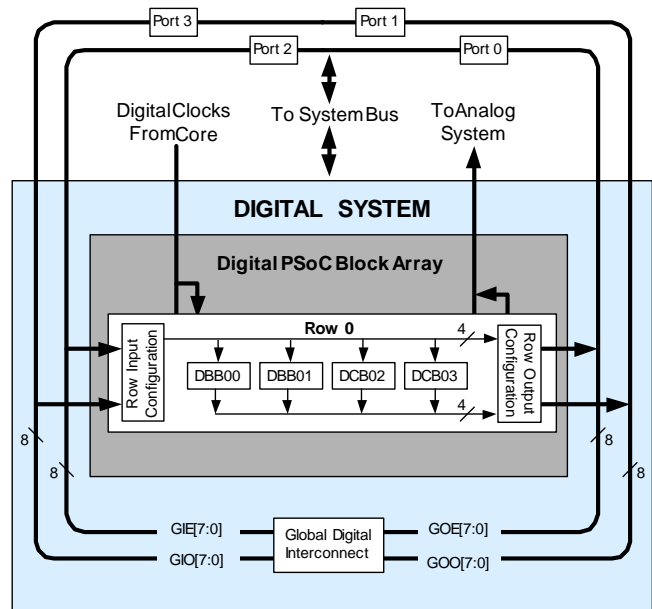

The Analog System

The Analog System consists of 4 configurable blocks that allow the creation of complex analog signal flows. Analog peripherals are very flexible and may be customized to support specific application requirements. Some of the common PSoC analog functions for this device (most available as user modules) are:

- Analog-to-digital converters (single or dual, with 8-bit resolution)
- Pin-to-pin comparator
- Single-ended comparators (up to 2) with absolute (1.3V) reference or 8-bit DAC reference
- 1.3V reference (as a System Resource)

In most PSoC devices, analog blocks are provided in columns of three, which includes one CT (Continuous Time) and two SC (Switched Capacitor) blocks. The CY8C21x34 devices provide limited functionality Type “E” analog blocks. Each column contains one CT Type E block and one SC Type E block. Refer to the *PSoC Mixed-Signal Array Technical Reference Manual* for detailed information on the CY8C21x34’s Type E analog blocks.

Figure 2. Analog System Block Diagram

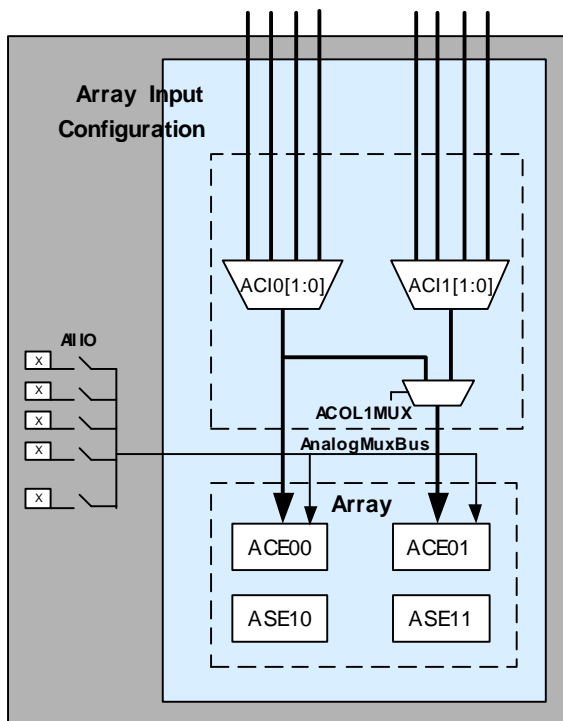

The Analog Multiplexer System

The Analog Mux Bus can connect to every GPIO pin. Pins may be connected to the bus individually or in any combination. The bus also connects to the analog system for analysis with comparators and analog-to-digital converters. An additional 8:1 analog input multiplexer provides a second path to bring Port 0 pins to the analog array.

Switch control logic enables selected pins to precharge continuously under hardware control. This enables capacitive measurement for applications such as touch sensing. Other multiplexer applications include:

- Track pad, finger sensing.
- Chip-wide mux that allows analog input from any IO pin.
- Crosspoint connection between any IO pin combinations.

When designing capacitive sensing applications, refer to the signal-to-noise system level requirement found in Application Note [AN2403](http://www.cypress.com) on the Cypress web site at <http://www.cypress.com>.

Additional System Resources

System Resources, some of which are listed in the previous sections, provide additional capability useful to complete systems. Additional resources include a switch mode pump, low voltage detection, and power on reset. Brief statements describing the merits of each system resource follow.

- Digital clock dividers provide three customizable clock frequencies for use in applications. The clocks may be routed to both the digital and analog systems. Additional clocks can be generated using digital PSoC blocks as clock dividers.
- The I2C module provides 100 and 400 kHz communication over two wires. Slave, master, and multi-master modes are all supported.
- Low Voltage Detection (LVD) interrupts can signal the application of falling voltage levels, while the advanced POR (Power On Reset) circuit eliminates the need for a system supervisor.
- An internal 1.3 voltage reference provides an absolute reference for the analog system, including ADCs and DACs.
- An integrated switch mode pump (SMP) generates normal operating voltages from a single 1.2V battery cell, providing a low cost boost converter.
- Versatile analog multiplexer system.

PSoC Device Characteristics

Depending on your PSoC device characteristics, the digital and analog systems can have 16, 8, or 4 digital blocks and 12, 6, or 4 analog blocks. Table 1 lists the resources available for specific PSoC device groups. The PSoC device covered by this data sheet is highlighted in this table.

Table 1. PSoC Device Characteristics

PSoC Part Number	Digital IO	Digital Rows	Digital Blocks	Analog Inputs	Analog Outputs	Analog Columns	Analog Blocks	SRAM Size	Flash Size
CY8C29x66	up to 64	4	16	12	4	4	12	2K	32K
CY8C27x43	up to 44	2	8	12	4	4	12	256 Bytes	16K
CY8C24x94	56	1	4	48	2	2	6	1K	16K
CY8C24x23A	up to 24	1	4	12	2	2	6	256 Bytes	4K
CY8C21x34	up to 28	1	4	28	0	2	4 ^a	512 Bytes	8K
CY8C21x23	16	1	4	8	0	2	4 ^a	256 Bytes	4K
CY8C20x34	up to 28	0	0	28	0	0	3 ^b	512 Bytes	8K

a. Limited analog functionality.

b. Two analog blocks and one CapSense.

Getting Started

The quickest path to understanding the PSoC silicon is by reading this data sheet and using the PSoC Designer Integrated Development Environment (IDE). This data sheet is an overview of the PSoC integrated circuit and presents specific pin, register, and electrical specifications. For in-depth information with detailed programming information, refer the *PSoC Mixed-Signal Array Technical Reference Manual* available at <http://www.cypress.com/psoc>.

For up-to-date Ordering, Packaging, and Electrical Specification information, refer the latest PSoC device data sheets at <http://www.cypress.com>.

Development Kits

Development Kits are available from the following distributors: Digi-Key, Avnet, Arrow, and Future. The Cypress Online Store

contains development kits, C compilers, and all accessories for PSoC development. Go to the Cypress Online Store web site at <http://www.cypress.com>, click the Online Store shopping cart icon at the bottom of the web page, and click *PSoC (Programmable System-on-Chip)* to view a current list of available items.

Technical Training Modules

Free PSoC technical training modules are available for users new to PSoC. Training modules cover designing, debugging, advanced analog and CapSense. Go to <http://www.cypress.com/techtrain>.

Consultants

Certified PSoC Consultants offer everything from technical assistance to completed PSoC designs. To contact or become a PSoC Consultant go to <http://www.cypress.com>, click on Design Support located on the left side of the web page, and select CYPros Consultants.

Technical Support

PSoC application engineers take pride in fast and accurate response. They can be reached with a 4-hour guaranteed response at <http://www.cypress.com/support>.

Application Notes

A long list of application notes can assist you in every aspect of your design effort. To view the PSoC application notes, go to the <http://www.cypress.com> web site and select Application Notes under the Design Resources list located in the center of the web page. Application notes are sorted by date by default.

Development Tools

PSoC Designer is a Microsoft® Windows-based, integrated development environment for the Programmable System-on-Chip (PSoC) devices. The PSoC Designer IDE and application runs on Windows NT 4.0, Windows 2000, Windows Millennium (Me), or Windows XP. (See Figure 3 on page 5)

PSoC Designer helps the customer to select an operating configuration for the PSoC, write application code that uses the PSoC, and debug the application. This system provides design database management by project, an integrated debugger with In-Circuit Emulator, in-system programming support, and the CYASM macro assembler for the CPUs.

PSoC Designer also supports a high-level C language compiler developed specifically for the devices in the family.

Figure 3. PSoC Designer Subsystems

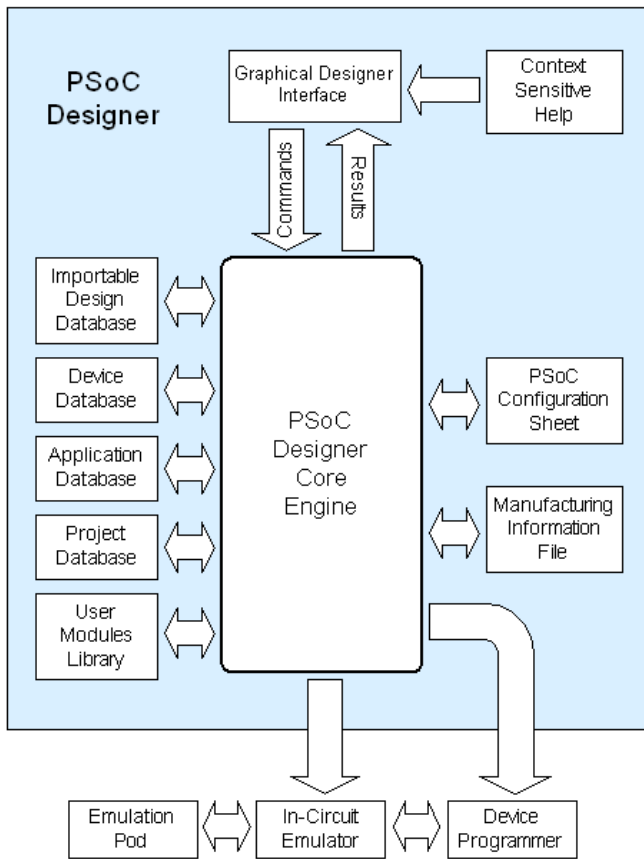

PSoC Designer Software Subsystems

Device Editor

The device editor subsystem enables the user to select different onboard analog and digital components called user modules using the PSoC blocks. Examples of user modules are ADCs, DACs, Amplifiers, and Filters.

The device editor also supports easy development of multiple configurations and dynamic reconfiguration. Dynamic reconfiguration allows changing configurations at run time.

PSoC Designer sets up power on initialization tables for selected PSoC block configurations and creates source code for an application framework. The framework contains software to operate the selected components and, if the project uses more than one operating configuration, contains routines to switch between different sets of PSoC block configurations at run time. PSoC Designer can print out a configuration sheet for a given project configuration for use during application programming in conjunction with the Device Data Sheet. After the framework is generated, the user can add application-specific code to flesh out the framework. It is also possible to change the selected components and regenerate the framework.

Design Browser

The Design Browser enables users to select and import preconfigured designs into the user's project. Users can easily browse a catalog of preconfigured designs to facilitate time-to-design. Examples provided in the tools include a 300-baud modem, LIN Bus master and slave, fan controller, and magnetic card reader.

Application Editor

In the Application Editor you can edit your C language and Assembly language source code. You can also assemble, compile, link, and build.

Assembler. The macro assembler allows the seamless merging of the assembly code with C code. The link libraries automatically use absolute addressing or are compiled in relative mode, and linked with other software modules to get absolute addressing.

C Language Compiler. A C language compiler that supports the PSoC family of devices is available. Even if you have never worked in the C language before, the product quickly helps you create complete C programs for the PSoC family devices.

The embedded, optimizing C compiler provides all the features of C tailored to the PSoC architecture. It comes complete with embedded libraries providing port and bus operations, standard keypad and display support, and extended math functionality.

Debugger

The PSoC Designer Debugger subsystem provides hardware in-circuit emulation, allowing the designer to test the program in a physical system while providing an internal view of the PSoC device. Debugger commands allow the designer to read the program and read and write data memory, read and write IO registers, read and write CPU registers, set and clear breakpoints, and provide program run, halt, and step control. The debugger also allows the designer to create a trace buffer of registers and memory locations of interest.

Online Help System

The online help system displays online, context-sensitive help for the user. Designed for procedural and quick reference, each functional subsystem has its own context-sensitive help. This system also provides tutorials and links to FAQs and an Online Support Forum to aid the designer in getting started.

Hardware Tools

In-Circuit Emulator

A low cost, high functionality ICE (In-Circuit Emulator) is available for development support. This hardware has the capability to program single devices.

The emulator consists of a base unit that connects to the PC by way of a USB port. The base unit is universal and operates with all PSoC devices. Emulation pods for each device family are available separately. The emulation pod takes the place of the PSoC device in the target board and performs full speed (24 MHz) operation.

Designing with User Modules

The development process for the PSoC device differs from that of a traditional fixed function microprocessor. The configurable analog and digital hardware blocks give the PSoC architecture a unique flexibility that pays dividends in managing specification change during development and by lowering inventory costs. These configurable resources, called PSoC Blocks, have the ability to implement a wide variety of user-selectable functions. Each block has several registers that determine its function and connectivity to other blocks, multiplexers, buses and to the IO pins. Iterative development cycles permit you to adapt the hardware and software. This substantially lowers the risk of having to select a different part to meet the final design requirements.

To speed the development process, the PSoC Designer Integrated Development Environment (IDE) provides a library of pre-built, pre-tested hardware peripheral functions, called "User Modules." User modules make selecting and implementing peripheral devices simple, and come in analog, digital, and mixed signal varieties. The standard User Module library contains over 50 common peripherals such as ADCs, DACs Timers, Counters, UARTs, and other uncommon peripherals, such as DTMF Generators and Bi-Quad analog filter sections.

Each user module establishes the basic register settings that implement the selected function. It also provides parameters that allow you to tailor its precise configuration to your particular application. For example, a Pulse Width Modulator User Module configures one or more digital PSoC blocks, one for each 8 bits of resolution. The user module parameters permit you to establish the pulse width and duty cycle. User modules also provide tested software to cut your development time. The user module application programming interface (API) provides high-level functions to control and respond to hardware events at run time. The API also provides optional interrupt service routines that you can adapt as needed.

The API functions are documented in user module data sheets that are viewed directly in the PSoC Designer IDE. These data sheets explain the internal operation of the user module and provide performance specifications. Each data sheet describes the use of each user module parameter and documents the setting of each register controlled by the user module.

The development process starts when you open a new project and bring up the Device Editor, a graphical user interface (GUI) for configuring the hardware. You can pick the user modules you need for your project and map them onto the PSoC blocks with point-and-click simplicity. Next, you build signal chains by inter-connecting user modules to each other and the IO pins. At this stage, you must also configure the clock source connections and enter parameter values directly or by selecting values from drop-down menus. When you are ready to test the hardware configuration or move on to developing code for the project, perform the "Generate Application" step. This causes PSoC Designer to generate source code that automatically configures the device to your specification and provides the high-level user module API functions.

Figure 4. User Module and Source Code Development Flows

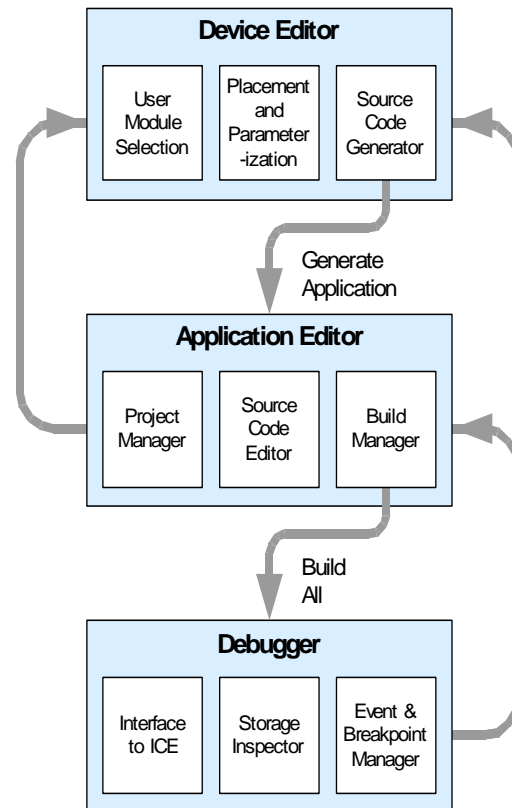

The next step is to write your main program, and any sub-routines using PSoC Designer's Application Editor subsystem. The Application Editor includes a Project Manager that allows you to open the project source code files (including all generated code files) from a hierarchical view. The source code editor provides syntax coloring and advanced edit features for both C and assembly language. File search capabilities include simple string searches and recursive "grep-style" patterns. A single mouse click invokes the Build Manager. It employs a professional-strength "makefile" system to automatically analyze all file dependencies and run the compiler and assembler as necessary. Project-level options control optimization strategies used by the compiler and linker. Syntax errors are displayed in a console window. Double clicking the error message takes you directly to the offending line of source code. When all is correct, the linker builds a HEX file image suitable for programming.

The last step in the development process takes place inside the PSoC Designer's Debugger subsystem. The Debugger downloads the HEX image to the In-Circuit Emulator (ICE) where it runs at full speed. Debugger capabilities rival those of systems costing many times more. In addition to traditional single-step, run-to-breakpoint and watch-variable features, the Debugger provides a large trace buffer and enables you to define complex breakpoint events that include monitoring address and data bus values, memory locations, and external signals.

Document Conventions

Acronyms Used

The following table lists the acronyms that are used in this document.

Table 2. Acronyms Used

Acronym	Description
AC	alternating current
ADC	analog-to-digital converter
API	application programming interface
CPU	central processing unit
CT	continuous time
DAC	digital-to-analog converter
DC	direct current
ECO	external crystal oscillator
EEPROM	electrically erasable programmable read-only memory
FSR	full scale range
GPIO	general purpose IO
GUI	graphical user interface
HBM	human body model
ICE	in-circuit emulator
ILO	internal low speed oscillator
IMO	internal main oscillator
IO	input/output
IPOR	imprecise power on reset
LSb	least-significant bit
LVD	low voltage detect
MSb	most-significant bit
PC	program counter
PLL	phase-locked loop
POR	power on reset
PPOR	precision power on reset
PSoC®	Programmable System-on-Chip™
PWM	pulse width modulator
SC	switched capacitor
SLIMO	slow IMO
SMP	switch mode pump
SRAM	static random access memory

Units of Measure

A units of measure table is located in the Electrical Specifications section. [Table 2](#) on page 7 lists all the abbreviations used to measure the PSoC devices.

Numeric Naming

Hexidecimal numbers are represented with all letters in uppercase with an appended lowercase 'h' (for example, '14h' or '3Ah'). Hexidecimal numbers may also be represented by a '0x' prefix, the C coding convention. Binary numbers have an appended lowercase 'b' (e.g., '01010100b' or '01000011b'). Numbers not indicated by an 'h', 'b', or 0x are decimal.

Pin Information

The CY8C21x34 PSoC device is available in a variety of packages which are listed in the following tables. Every port pin (labeled with a "P") is capable of Digital IO and connection to the common analog bus. However, Vss, Vdd, SMP, and XRES are not capable of Digital IO.

16-Pin Part Pinout

Figure 5. CY8C21234 16-Pin PSoC Device

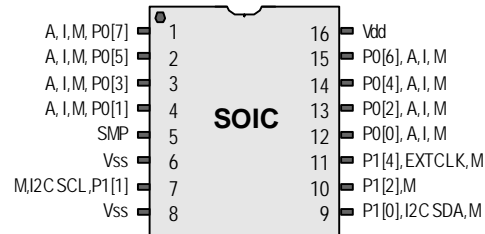

Table 3. Pin Definitions - CY8C21234 16-Pin (SOIC)

Pin No.	Type		Name	Description
	Digital	Analog		
1	IO	I, M	P0[7]	Analog column mux input.
2	IO	I, M	P0[5]	Analog column mux input.
3	IO	I, M	P0[3]	Analog column mux input, integrating input.
4	IO	I, M	P0[1]	Analog column mux input, integrating input.
5	Power		SMP	Switch Mode Pump (SMP) connection to required external components.
6	Power		Vss	Ground connection.
7	IO	M	P1[1]	I2C Serial Clock (SCL), ISSP-SCLK*.
8	Power		Vss	Ground connection.
9	IO	M	P1[0]	I2C Serial Data (SDA), ISSP-SDATA*.
10	IO	M	P1[2]	
11	IO	M	P1[4]	Optional External Clock Input (EXTCLK).
12	IO	I, M	P0[0]	Analog column mux input.
13	IO	I, M	P0[2]	Analog column mux input.
14	IO	I, M	P0[4]	Analog column mux input.
15	IO	I, M	P0[6]	Analog column mux input.
16	Power		Vdd	Supply voltage.

LEGEND A = Analog, I = Input, O = Output, and M = Analog Mux Input.

* These are the ISSP pins, which are not High Z at POR (Power On Reset). See the PSoC Mixed-Signal Array Technical Reference Manual for details.

20-Pin Part Pinout

Figure 6. CY8C21334 20-Pin PSoC Device

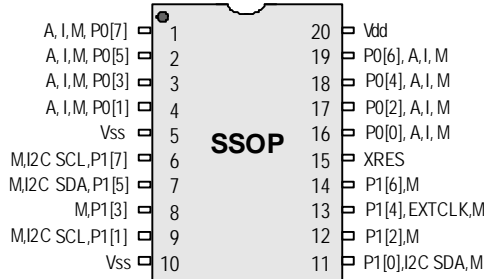

Table 4. Pin Definitions - CY8C21334 20-Pin (SSOP)

Pin No.	Type		Name	Description
	Digital	Analog		
1	IO	I, M	P0[7]	Analog column mux input.
2	IO	I, M	P0[5]	Analog column mux input.
3	IO	I, M	P0[3]	Analog column mux input, integrating input.
4	IO	I, M	P0[1]	Analog column mux input, integrating input.
5	Power		Vss	Ground connection.
6	IO	M	P1[7]	I2C Serial Clock (SCL).
7	IO	M	P1[5]	I2C Serial Data (SDA).
8	IO	M	P1[3]	
9	IO	M	P1[1]	I2C Serial Clock (SCL), ISSP-SCLK*.
10	Power		Vss	Ground connection.
11	IO	M	P1[0]	I2C Serial Data (SDA), ISSP-SDATA*.
12	IO	M	P1[2]	
13	IO	M	P1[4]	Optional External Clock Input (EXTCLK).
14	IO	M	P1[6]	
15	Input		XRES	Active high external reset with internal pull down.
16	IO	I, M	P0[0]	Analog column mux input.
17	IO	I, M	P0[2]	Analog column mux input.
18	IO	I, M	P0[4]	Analog column mux input.
19	IO	I, M	P0[6]	Analog column mux input.
20	Power		Vdd	Supply voltage.

LEGEND A = Analog, I = Input, O = Output, and M = Analog Mux Input.

* These are the ISSP pins, which are not High Z at POR (Power On Reset). See the PSoC Mixed-Signal Array Technical Reference Manual for details.

28-Pin Part Pinout

Figure 7. CY8C21534 28-Pin PSoC Device

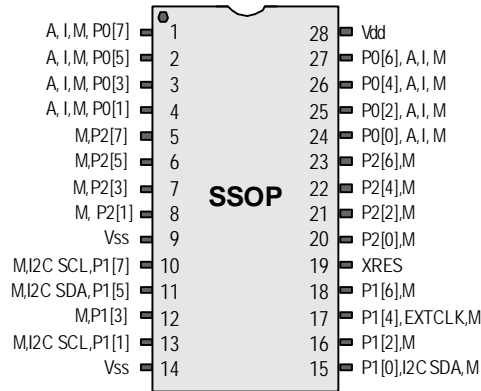

Table 5. Pin Definitions - CY8C21534 28-Pin (SSOP)

Pin No.	Type		Name	Description
	Digital	Analog		
1	IO	I, M	P0[7]	Analog column mux input.
2	IO	I, M	P0[5]	Analog column mux input and column output.
3	IO	I, M	P0[3]	Analog column mux input and column output, integrating input.
4	IO	I, M	P0[1]	Analog column mux input, integrating input.
5	IO	M	P2[7]	
6	IO	M	P2[5]	
7	IO	I, M	P2[3]	Direct switched capacitor block input.
8	IO	I, M	P2[1]	Direct switched capacitor block input.
9	Power		Vss	Ground connection.
10	IO	M	P1[7]	I2C Serial Clock (SCL).
11	IO	M	P1[5]	I2C Serial Data (SDA).
12	IO	M	P1[3]	
13	IO	M	P1[1]	I2C Serial Clock (SCL), ISSP-SCLK*.
14	Power		Vss	Ground connection.
15	IO	M	P1[0]	I2C Serial Data (SDA), ISSP-SDATA*.
16	IO	M	P1[2]	
17	IO	M	P1[4]	Optional External Clock Input (EXTCLK).
18	IO	M	P1[6]	
19	Input		XRES	Active high external reset with internal pull down.
20	IO	I, M	P2[0]	Direct switched capacitor block input.
21	IO	I, M	P2[2]	Direct switched capacitor block input.
22	IO	M	P2[4]	
23	IO	M	P2[6]	
24	IO	I, M	P0[0]	Analog column mux input.
25	IO	I, M	P0[2]	Analog column mux input.
26	IO	I, M	P0[4]	Analog column mux input
27	IO	I, M	P0[6]	Analog column mux input.
28	Power		Vdd	Supply voltage.

LEGEND A: Analog, I: Input, O = Output, and M = Analog Mux Input.

* These are the ISSP pins, which are not High Z at POR (Power On Reset). See the PSoC Mixed-Signal Array Technical Reference Manual for details.

32-Pin Part Pinout

Figure 8. CY8C21434 32-Pin PSoC Device

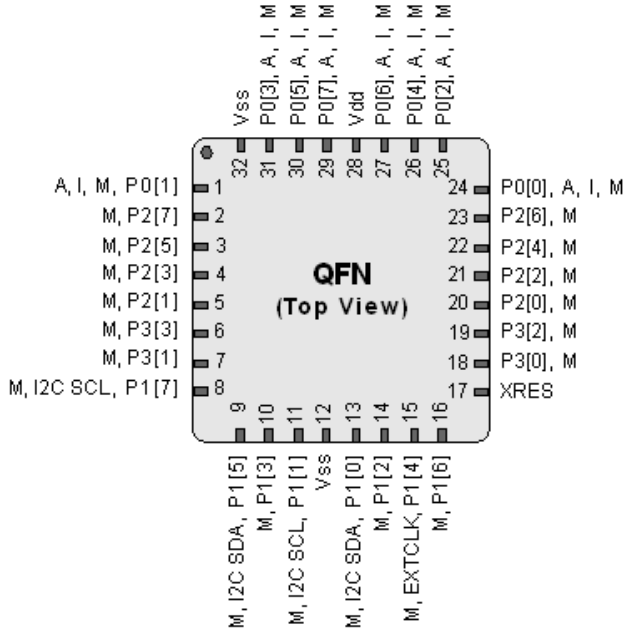

Figure 9. CY8C21634 32-Pin PSoC Device

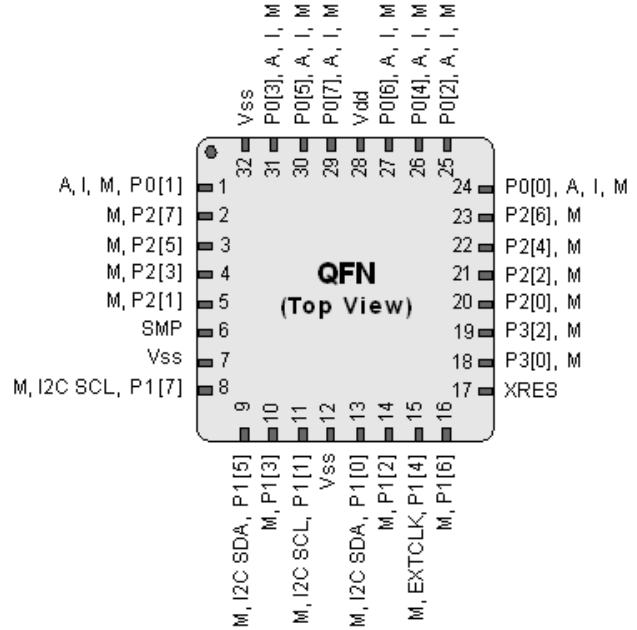

Figure 10. CY8C21434 32-Pin Sawn PSoC Device

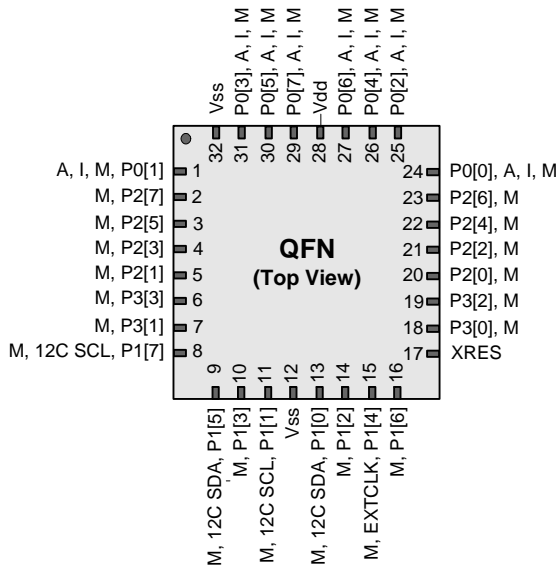

Figure 11. CY8C21634 32-Pin Sawn PSoC Device

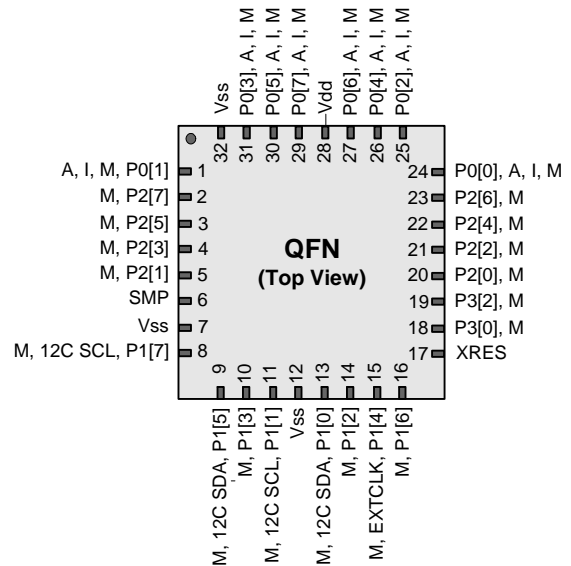

Table 6. Pin Definitions - CY8C21434/CY8C21634 32-Pin (QFN)**

Pin No.	Type		Name	Description
	Digital	Analog		
1	IO	I, M	P0[1]	Analog column mux input, integrating input.
2	IO	M	P2[7]	
3	IO	M	P2[5]	
4	IO	M	P2[3]	
5	IO	M	P2[1]	
6	IO	M	P3[3]	In CY8C21434 part.
6	Power		SMP	Switch Mode Pump (SMP) connection to required external components in CY8C21634 part.
7	IO	M	P3[1]	In CY8C21434 part.
7	Power		Vss	Ground connection in CY8C21634 part.
8	IO	M	P1[7]	I2C Serial Clock (SCL).
9	IO	M	P1[5]	I2C Serial Data (SDA).
10	IO	M	P1[3]	
11	IO	M	P1[1]	I2C Serial Clock (SCL), ISSP-SCLK*.
12	Power		Vss	Ground connection.
13	IO	M	P1[0]	I2C Serial Data (SDA), ISSP-SDATA*.
14	IO	M	P1[2]	
15	IO	M	P1[4]	Optional External Clock Input (EXTCLK).
16	IO	M	P1[6]	
17	Input		XRES	Active high external reset with internal pull down.
18	IO	M	P3[0]	
19	IO	M	P3[2]	
20	IO	M	P2[0]	
21	IO	M	P2[2]	
22	IO	M	P2[4]	
23	IO	M	P2[6]	
24	IO	I, M	P0[0]	Analog column mux input.
25	IO	I, M	P0[2]	Analog column mux input.
26	IO	I, M	P0[4]	Analog column mux input.
27	IO	I, M	P0[6]	Analog column mux input.
28	Power		Vdd	Supply voltage.
29	IO	I, M	P0[7]	Analog column mux input.
30	IO	I, M	P0[5]	Analog column mux input.
31	IO	I, M	P0[3]	Analog column mux input, integrating input.
32	Power		Vss	Ground connection.

LEGEND A = Analog, I = Input, O = Output, and M = Analog Mux Input.

* These are the ISSP pins, which are not High Z at POR (Power On Reset). See the PSoC Mixed-Signal Array Technical Reference Manual for details.

** The center pad on the QFN package must be connected to ground (Vss) for best mechanical, thermal, and electrical performance. If not connected to ground, it must be electrically floated and not connected to any other signal.

56-Pin Part Pinout

The 56-pin SSOP part is for the CY8C21001 On-Chip Debug (OCD) PSoC device.

Note This part is only used for in-circuit debugging. It is NOT available for production.

Figure 12. CY8C21001 56-Pin PSoC Device

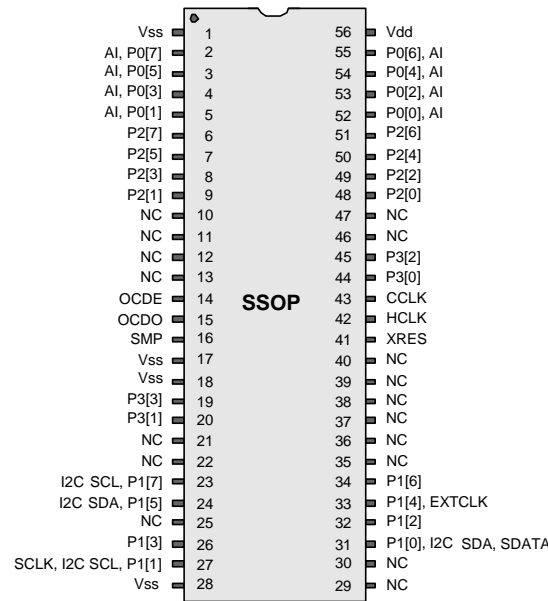

Table 7. Pin Definitions - CY8C21001 56-Pin (SSOP)

Pin No.	Type		Pin Name	Description
	Digital	Analog		
1	Power		Vss	Ground connection.
2	IO	I	P0[7]	Analog column mux input.
3	IO	I	P0[5]	Analog column mux input and column output.
4	IO	I	P0[3]	Analog column mux input and column output.
5	IO	I	P0[1]	Analog column mux input.
6	IO		P2[7]	
7	IO		P2[5]	
8	IO	I	P2[3]	Direct switched capacitor block input.
9	IO	I	P2[1]	Direct switched capacitor block input.
10			NC	No connection.
11			NC	No connection.
12			NC	No connection.
13			NC	No connection.
14	OCD		OCDE	OCD even data IO.
15	OCD		OCDO	OCD odd data output.
16	Power		SMP	Switch Mode Pump (SMP) connection to required external components.
17	Power		Vss	Ground connection.
18	Power		Vss	Ground connection.
19	IO		P3[3]	

Table 7. Pin Definitions - CY8C21001 56-Pin (SSOP) (continued)

Pin No.	Type		Pin Name	Description
	Digital	Analog		
20	IO		P3[1]	
21			NC	No connection.
22			NC	No connection.
23	IO		P1[7]	I2C Serial Clock (SCL).
24	IO		P1[5]	I2C Serial Data (SDA).
25			NC	No connection.
26	IO		P1[3]	I _{FMTEST}
27	IO		P1[1]	Crystal Input (XTALin), I2C Serial Clock (SCL), ISSP-SCLK*.
28	Power		Vss	Ground connection.
29			NC	No connection.
30			NC	No connection.
31	IO		P1[0]	Crystal Output (XTALout), I2C Serial Data (SDA), ISSP-SDATA*.
32	IO		P1[2]	V _{FMTEST}
33	IO		P1[4]	Optional External Clock Input (EXTCLK).
34	IO		P1[6]	
35			NC	No connection.
36			NC	No connection.
37			NC	No connection.
38			NC	No connection.
39			NC	No connection.
40			NC	No connection.
41	Input		XRES	Active high external reset with internal pull down.
42	OCD		HCLK	OCD high-speed clock output.
43	OCD		CCLK	OCD CPU clock output.
44	IO		P3[0]	
45	IO		P3[2]	
46			NC	No connection.
47			NC	No connection.
48	IO	I	P2[0]	
49	IO	I	P2[2]	
50	IO		P2[4]	
51	IO		P2[6]	
52	IO	I	P0[0]	Analog column mux input.
53	IO	I	P0[2]	Analog column mux input and column output.
54	IO	I	P0[4]	Analog column mux input and column output.
55	IO	I	P0[6]	Analog column mux input.
56	Power		Vdd	Supply voltage.

LEGEND: A = Analog, I = Input, O = Output, and OCD = On-Chip Debug.

* These are the ISSP pins, which are not High Z at POR (Power On Reset). See the *PSoC Mixed-Signal Array Technical Reference Manual* for details.

Register Reference

This chapter lists the registers of the CY8C21x34 PSoC device. For detailed register information, refer the *PSoC Mixed-Signal Array Technical Reference Manual*.

Register Conventions

The register conventions specific to this section are listed in [Table 8](#).

Table 8. Register Conventions

Convention	Description
R	Read register or bit(s)
W	Write register or bit(s)
L	Logical register or bit(s)
C	Clearable register or bit(s)
#	Access is bit specific

Register Mapping Tables

The PSoC device has a total register address space of 512 bytes. The register space is referred to as IO space and is divided into two banks. The XO1 bit in the Flag register (CPU_F) determines which bank the user is currently in. When the XO1 bit is set the user is in Bank 1.

Note In the following register mapping tables, blank fields are Reserved and must not be accessed.

Table 9. Register Map 0 Table: User Space

Name	Addr (0,Hex)	Access	Name	Addr (0,Hex)	Access	Name	Addr (0,Hex)	Access	Name	Addr (0,Hex)	Access
PRT0DR	00	RW		40		ASE10CR0	80	RW		C0	
PRT0IE	01	RW		41			81			C1	
PRT0GS	02	RW		42			82			C2	
PRT0DM2	03	RW		43			83			C3	
PRT1DR	04	RW		44		ASE11CR0	84	RW		C4	
PRT1IE	05	RW		45			85			C5	
PRT1GS	06	RW		46			86			C6	
PRT1DM2	07	RW		47			87			C7	
PRT2DR	08	RW		48			88			C8	
PRT2IE	09	RW		49			89			C9	
PRT2GS	0A	RW		4A			8A			CA	
PRT2DM2	0B	RW		4B			8B			CB	
PRT3DR	0C	RW		4C			8C			CC	
PRT3IE	0D	RW		4D			8D			CD	
PRT3GS	0E	RW		4E			8E			CE	
PRT3DM2	0F	RW		4F			8F			CF	
	10			50			90		CUR_PP	D0	RW
	11			51			91		STK_PP	D1	RW
	12			52			92			D2	
	13			53			93		IDX_PP	D3	RW
	14			54			94		MVR_PP	D4	RW
	15			55			95		MVW_PP	D5	RW
	16			56			96		I2C_CFG	D6	RW
	17			57			97		I2C_SCR	D7	#
	18			58			98		I2C_DR	D8	RW
	19			59			99		I2C_MSCR	D9	#
	1A			5A			9A		INT_CLR0	DA	RW
	1B			5B			9B		INT_CLR1	DB	RW
	1C			5C			9C			DC	
	1D			5D			9D		INT_CLR3	DD	RW
	1E			5E			9E		INT_MSK3	DE	RW
	1F			5F			9F			DF	

Blank fields are Reserved and must not be accessed.

Access is bit specific.

Table 9. Register Map 0 Table: User Space (continued)

Name	Addr (0,Hex)	Access	Name	Addr (0,Hex)	Access	Name	Addr (0,Hex)	Access	Name	Addr (0,Hex)	Access
DBB00DR0	20	#	AMX_IN	60	RW		A0		INT_MSK0	E0	RW
DBB00DR1	21	W	AMUXCFG	61	RW		A1		INT_MSK1	E1	RW
DBB00DR2	22	RW	PWM_CR	62	RW		A2		INT_VC	E2	RC
DBB00CR0	23	#		63			A3		RES_WDT	E3	W
DBB01DR0	24	#	CMP_CR0	64	#		A4			E4	
DBB01DR1	25	W		65			A5			E5	
DBB01DR2	26	RW	CMP_CR1	66	RW		A6		DEC_CR0	E6	RW
DBB01CR0	27	#		67			A7		DEC_CR1	E7	RW
DCB02DR0	28	#	ADC0_CR	68	#		A8			E8	
DCB02DR1	29	W	ADC1_CR	69	#		A9			E9	
DCB02DR2	2A	RW		6A			AA			EA	
DCB02CR0	2B	#		6B			AB			EB	
DCB03DR0	2C	#	TMP_DR0	6C	RW		AC			EC	
DCB03DR1	2D	W	TMP_DR1	6D	RW		AD			ED	
DCB03DR2	2E	RW	TMP_DR2	6E	RW		AE			EE	
DCB03CR0	2F	#	TMP_DR3	6F	RW		AF			EF	
	30			70		RDI0R1	B0	RW		F0	
	31			71		RDI0SYN	B1	RW		F1	
	32		ACE00CR1	72	RW	RDI0IS	B2	RW		F2	
	33		ACE00CR2	73	RW	RDI0LT0	B3	RW		F3	
	34			74		RDI0LT1	B4	RW		F4	
	35			75		RDI0RO0	B5	RW		F5	
	36		ACE01CR1	76	RW	RDI0RO1	B6	RW		F6	
	37		ACE01CR2	77	RW		B7		CPU_F	F7	RL
	38			78			B8			F8	
	39			79			B9			F9	
	3A			7A			BA			FA	
	3B			7B			BB			FB	
	3C			7C			BC			FC	
	3D			7D			BD		DAC_D	FD	RW
	3E			7E			BE		CPU_SCR1	FE	#
	3F			7F			BF		CPU_SCR0	FF	#

Blank fields are Reserved and must not be accessed.

Access is bit specific.

Table 10. Register Map 1 Table: Configuration Space

Name	Addr (1,Hex)	Access	Name	Addr (1,Hex)	Access	Name	Addr (1,Hex)	Access	Name	Addr (1,Hex)	Access
PRT0DM0	00	RW		40		ASE10CR0	80	RW		C0	
PRT0DM1	01	RW		41			81			C1	
PRT0IC0	02	RW		42			82			C2	
PRT0IC1	03	RW		43			83			C3	
PRT1DM0	04	RW		44		ASE11CR0	84	RW		C4	
PRT1DM1	05	RW		45			85			C5	
PRT1IC0	06	RW		46			86			C6	
PRT1IC1	07	RW		47			87			C7	
PRT2DM0	08	RW		48			88			C8	
PRT2DM1	09	RW		49			89			C9	
PRT2IC0	0A	RW		4A			8A			CA	
PRT2IC1	0B	RW		4B			8B			CB	
PRT3DM0	0C	RW		4C			8C			CC	
PRT3DM1	0D	RW		4D			8D			CD	
PRT3IC0	0E	RW		4E			8E			CE	
PRT3IC1	0F	RW		4F			8F			CF	
	10			50			90		GDI_O_IN	D0	RW
	11			51			91		GDI_E_IN	D1	RW
	12			52			92		GDI_O_OU	D2	RW
	13			53			93		GDI_E_OU	D3	RW
	14			54			94			D4	

Blank fields are Reserved and must not be accessed.

Access is bit specific.

Table 10. Register Map 1 Table: Configuration Space (continued)

Name	Addr (1,Hex)	Access	Name	Addr (1,Hex)	Access	Name	Addr (1,Hex)	Access	Name	Addr (1,Hex)	Access
	15			55			95			D5	
	16			56			96			D6	
	17			57			97			D7	
	18			58			98		MUX_CR0	D8	RW
	19			59			99		MUX_CR1	D9	RW
	1A			5A			9A		MUX_CR2	DA	RW
	1B			5B			9B		MUX_CR3	DB	RW
	1C			5C			9C			DC	
	1D			5D			9D		OSC_GO_EN	DD	RW
	1E			5E			9E		OSC_CR4	DE	RW
	1F			5F			9F		OSC_CR3	DF	RW
DBB00FN	20	RW	CLK_CR0	60	RW		A0		OSC_CR0	E0	RW
DBB00IN	21	RW	CLK_CR1	61	RW		A1		OSC_CR1	E1	RW
DBB00OU	22	RW	ABF_CR0	62	RW		A2		OSC_CR2	E2	RW
	23		AMD_CR0	63	RW		A3		VLT_CR	E3	RW
DBB01FN	24	RW	CMP_GO_EN	64	RW		A4		VLT_CMP	E4	R
DBB01IN	25	RW		65			A5		ADC0_TR	E5	RW
DBB01OU	26	RW	AMD_CR1	66	RW		A6		ADC1_TR	E6	RW
	27		ALT_CR0	67	RW		A7			E7	
DCB02FN	28	RW		68			A8		IMO_TR	E8	W
DCB02IN	29	RW		69			A9		ILO_TR	E9	W
DCB02OU	2A	RW		6A			AA		BDG_TR	EA	RW
	2B		CLK_CR3	6B	RW		AB		ECO_TR	EB	W
DCB03FN	2C	RW	TMP_DR0	6C	RW		AC			EC	
DCB03IN	2D	RW	TMP_DR1	6D	RW		AD			ED	
DCB03OU	2E	RW	TMP_DR2	6E	RW		AE			EE	
	2F		TMP_DR3	6F	RW		AF			EF	
	30			70		RDI0RI	B0	RW		F0	
	31			71		RDI0SYN	B1	RW		F1	
	32		ACE00CR1	72	RW	RDI0IS	B2	RW		F2	
	33		ACE00CR2	73	RW	RDI0LT0	B3	RW		F3	
	34			74		RDI0LT1	B4	RW		F4	
	35			75		RDI0RO0	B5	RW		F5	
	36		ACE01CR1	76	RW	RDI0RO1	B6	RW		F6	
	37		ACE01CR2	77	RW		B7		CPU_F	F7	RL
	38			78			B8			F8	
	39			79			B9			F9	
	3A			7A			BA		FLS_PR1	FA	RW
	3B			7B			BB			FB	
	3C			7C			BC			FC	
	3D			7D			BD		DAC_CR	FD	RW
	3E			7E			BE		CPU_SCR1	FE	#
	3F			7F			BF		CPU_SCR0	FF	#

Blank fields are Reserved and must not be accessed.

Access is bit specific.

Electrical Specifications

This section presents the DC and AC electrical specifications of the CY8C21x34 PSoC device. For up to date electrical specifications, visit the web site <http://www.cypress.com/psoc>.

Specifications are valid for $-40^{\circ}\text{C} \leq T_A \leq 85^{\circ}\text{C}$ and $T_J \leq 100^{\circ}\text{C}$ as specified, except where noted.

Refer [Table 25](#) on page 26 for the electrical specifications on the internal main oscillator (IMO) using SLIMO mode.

Figure 13. Voltage versus CPU Frequency

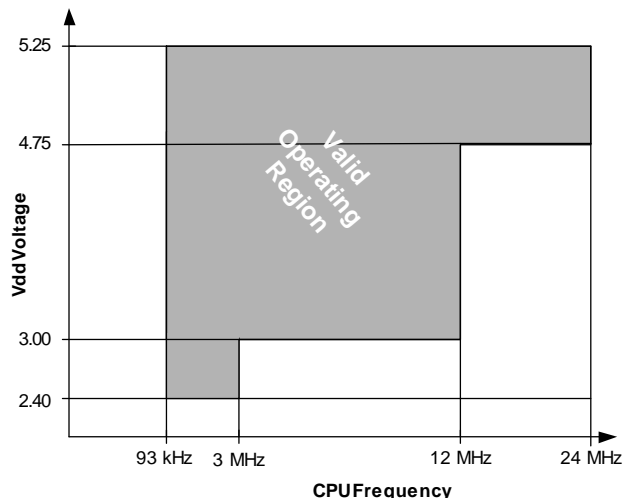
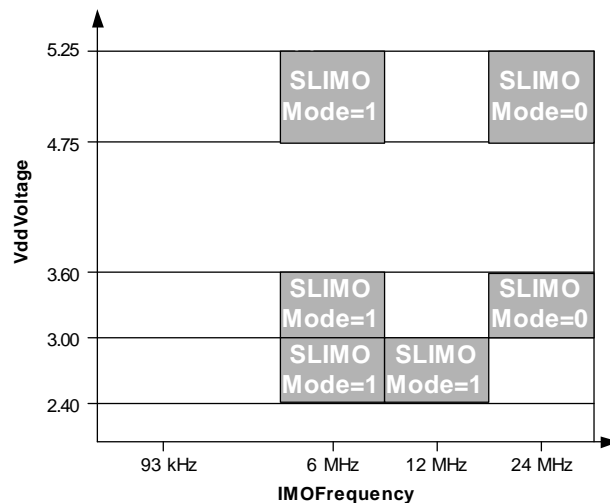

Figure 14. IMO Frequency Trim Options



[Table 11](#) lists the units of measure that are used in this section.

Table 11. Units of Measure

Symbol	Unit of Measure	Symbol	Unit of Measure
$^{\circ}\text{C}$	degree Celsius	μW	microwatts
dB	decibels	mA	milli-ampere
fF	femto farad	ms	milli-second
Hz	hertz	mV	milli-volts
KB	1024 bytes	nA	nanoampere
Kbit	1024 bits	ns	nanosecond
kHz	kilohertz	nV	nanovolts
k Ω	kilohm	W	ohm
MHz	megahertz	pA	picoampere
M Ω	megaohm	pF	picofarad
μA	microampere	pp	peak-to-peak
μF	microfarad	ppm	parts per million
μH	microhenry	ps	picosecond
μs	microsecond	sps	samples per second
μV	microvolts	s	sigma: one standard deviation
μV_{rms}	microvolts root-mean-square	V	volts

Absolute Maximum Ratings

Table 12. Absolute Maximum Ratings

Symbol	Description	Min	Typ	Max	Units	Notes
T _{STG}	Storage Temperature	-55	25	+100	°C	Higher storage temperatures reduce data retention time. Recommended storage temperature is +25°C ± 25°C. Extended duration storage temperatures above 65°C degrade reliability.
T _A	Ambient Temperature with Power Applied	-40	–	+85	°C	
V _{DD}	Supply Voltage on V _{DD} Relative to V _{SS}	-0.5	–	+6.0	V	
V _{IO}	DC Input Voltage	V _{SS} - 0.5	–	V _{DD} + 0.5	V	
V _{IOZ}	DC Voltage Applied to Tri-state	V _{SS} - 0.5	–	V _{DD} + 0.5	V	
I _{MIO}	Maximum Current into any Port Pin	-25	–	+50	mA	
ESD	Electro Static Discharge Voltage	2000	–	–	V	Human Body Model ESD.
LU	Latch-up Current	–	–	200	mA	

Operating Temperature

Table 13. Operating Temperature

Symbol	Description	Min	Typ	Max	Units	Notes
T _A	Ambient Temperature	-40	–	+85	°C	
T _J	Junction Temperature	-40	–	+100	°C	The temperature rise from ambient to junction is package specific. See Table 40 on page 37. The user must limit the power consumption to comply with this requirement.

DC Electrical Characteristics

DC Chip-Level Specifications

[Table 14](#) lists the guaranteed maximum and minimum specifications for the voltage and temperature ranges: 4.75V to 5.25V and -40°C ≤ T_A ≤ 85°C, 3.0V to 3.6V and -40°C ≤ T_A ≤ 85°C, or 2.4V to 3.0V and -40°C ≤ T_A ≤ 85°C, respectively. Typical parameters apply to 5V, 3.3V, or 2.7V at 25°C and are for design guidance only.

Table 14. DC Chip-Level Specifications

Symbol	Description	Min	Typ	Max	Units	Notes
V _{DD}	Supply Voltage	2.40	–	5.25	V	See Table 23 on page 24.
I _{DD}	Supply Current, IMO = 24 MHz	–	3	4	mA	Conditions are V _{DD} = 5.0V, T _A = 25°C, CPU = 3 MHz, 48 MHz disabled. VC1 = 1.5 MHz, VC2 = 93.75 kHz, VC3 = 0.366 kHz.
I _{DD3}	Supply Current, IMO = 6 MHz using SLIMO mode.	–	1.2	2	mA	Conditions are V _{DD} = 3.3V, T _A = 25°C, CPU = 3 MHz, clock doubler disabled. VC1 = 375 kHz, VC2 = 23.4 kHz, VC3 = 0.091 kHz.
I _{DD27}	Supply Current, IMO = 6 MHz using SLIMO mode.	–	1.1	1.5	mA	Conditions are V _{DD} = 2.55V, T _A = 25°C, CPU = 3 MHz, clock doubler disabled. VC1 = 375 kHz, VC2 = 23.4 kHz, VC3 = 0.091 kHz.

Table 14. DC Chip-Level Specifications (continued)

Symbol	Description	Min	Typ	Max	Units	Notes
I _{SB27}	Sleep (Mode) Current with POR, LVD, Sleep Timer, WDT, and internal slow oscillator active. Mid temperature range.	–	2.6	4.	μA	V _{dd} = 2.55V, 0°C ≤ T _A ≤ 40°C.
I _{SB}	Sleep (Mode) Current with POR, LVD, Sleep Timer, WDT, and internal slow oscillator active.	–	2.8	5	μA	V _{dd} = 3.3V, -40°C ≤ T _A ≤ 85°C.
V _{REF}	Reference Voltage (Bandgap)	1.28	1.30	1.32	V	Trimmed for appropriate V _{dd} . V _{dd} = 3.0V to 5.25V.
V _{REF27}	Reference Voltage (Bandgap)	1.16	1.30	1.33	V	Trimmed for appropriate V _{dd} . V _{dd} = 2.4V to 3.0V.
AGND	Analog Ground	V _{REF} - 0.003	V _{REF}	V _{REF} + 0.003	V	

DC General Purpose IO Specifications

The following tables list the guaranteed maximum and minimum specifications for the voltage and temperature ranges: 4.75V to 5.25V and -40°C ≤ T_A ≤ 85°C, 3.0V to 3.6V and -40°C ≤ T_A ≤ 85°C, or 2.4V to 3.0V and -40°C ≤ T_A ≤ 85°C, respectively. Typical parameters apply to 5V, 3.3V, and 2.7V at 25°C and are for design guidance only.

Table 15. 5V and 3.3V DC GPIO Specifications

Symbol	Description	Min	Typ	Max	Units	Notes
R _{PU}	Pull up Resistor	4	5.6	8	kΩ	
R _{PD}	Pull down Resistor	4	5.6	8	kΩ	
V _{OH}	High Output Level	V _{dd} - 1.0	–	–	V	I _{OH} = 10 mA, V _{dd} = 4.75 to 5.25V (8 total loads, 4 on even port pins (for example, P0[2], P1[4]), 4 on odd port pins (for example, P0[3], P1[5])).
V _{OL}	Low Output Level	–	–	0.75	V	I _{OL} = 25 mA, V _{dd} = 4.75 to 5.25V (8 total loads, 4 on even port pins (for example, P0[2], P1[4]), 4 on odd port pins (for example, P0[3], P1[5])).
V _{IL}	Input Low Level	–	–	0.8	V	V _{dd} = 3.0 to 5.25.
V _{IH}	Input High Level	2.1	–	–	V	V _{dd} = 3.0 to 5.25.
V _H	Input Hysteresis	–	60	–	mV	
I _{IL}	Input Leakage (Absolute Value)	–	1	–	nA	Gross tested to 1 μA.
C _{IN}	Capacitive Load on Pins as Input	–	3.5	10	pF	Package and pin dependent. Temp = 25°C.
C _{OUT}	Capacitive Load on Pins as Output	–	3.5	10	pF	Package and pin dependent. Temp = 25°C.

Table 16. 2.7V DC GPIO Specifications

Symbol	Description	Min	Typ	Max	Units	Notes
R _{PU}	Pull up Resistor	4	5.6	8	kΩ	
R _{PD}	Pull down Resistor	4	5.6	8	kΩ	
V _{OH}	High Output Level	V _{dd} - 0.4	–	–	V	I _{OH} = 2.5 mA (6.25 Typ), V _{dd} = 2.4 to 3.0V (16 mA maximum, 50 mA Typ combined I _{OH} budget).
V _{OL}	Low Output Level	–	–	0.75	V	I _{OL} = 10 mA, V _{dd} = 2.4 to 3.0V (90 mA maximum combined I _{OL} budget).
V _{IL}	Input Low Level	–	–	0.75	V	V _{dd} = 2.4 to 3.0.

Table 16. 2.7V DC GPIO Specifications (continued)

Symbol	Description	Min	Typ	Max	Units	Notes
V _{IH}	Input High Level	2.0	–	–	V	V _{dd} = 2.4 to 3.0.
V _H	Input Hysteresis	–	90	–	mV	
I _{IL}	Input Leakage (Absolute Value)	–	1	–	nA	Gross tested to 1 μA.
C _{IN}	Capacitive Load on Pins as Input	–	3.5	10	pF	Package and pin dependent. Temp = 25°C.
C _{OUT}	Capacitive Load on Pins as Output	–	3.5	10	pF	Package and pin dependent. Temp = 25°C.

DC Operational Amplifier Specifications

The following tables list the guaranteed maximum and minimum specifications for the voltage and temperature ranges: 4.75V to 5.25V and -40°C ≤ T_A ≤ 85°C, 3.0V to 3.6V and -40°C ≤ T_A ≤ 85°C, or 2.4V to 3.0V and -40°C ≤ T_A ≤ 85°C, respectively. Typical parameters apply to 5V, 3.3V, or 2.7V at 25°C and are for design guidance only.

Table 17. 5V DC Operational Amplifier Specifications

Symbol	Description	Min	Typ	Max	Units	Notes
V _{OSOA}	Input Offset Voltage (absolute value)	–	2.5	15	mV	
TCV _{OSOA}	Average Input Offset Voltage Drift	–	10	–	μV/°C	
I _{EBOA} ^a	Input Leakage Current (Port 0 Analog Pins)	–	200	–	pA	Gross tested to 1 μA.
C _{INOA}	Input Capacitance (Port 0 Analog Pins)	–	4.5	9.5	pF	Package and pin dependent. Temp = 25°C.
V _{CMOA}	Common Mode Voltage Range	0.0	–	V _{dd} - 1	V	
G _{OLOA}	Open Loop Gain	–	80	–	dB	
I _{SOA}	Amplifier Supply Current	–	10	30	μA	

a. Atypical behavior: I_{EBOA} of Port 0 Pin 0 is below 1 nA at 25°C; 50 nA over temperature. Use Port 0 Pins 1-7 for the lowest leakage of 200 nA.

Table 18. 3.3V DC Operational Amplifier Specifications

Symbol	Description	Min	Typ	Max	Units	Notes
V _{OSOA}	Input Offset Voltage (absolute value)	–	2.5	15	mV	
TCV _{OSOA}	Average Input Offset Voltage Drift	–	10	–	μV/°C	
I _{EBOA} ^a	Input Leakage Current (Port 0 Analog Pins)	–	200	–	pA	Gross tested to 1 μA.
C _{INOA}	Input Capacitance (Port 0 Analog Pins)	–	4.5	9.5	pF	Package and pin dependent. Temp = 25°C.
V _{CMOA}	Common Mode Voltage Range	0	–	V _{dd} - 1	V	
G _{OLOA}	Open Loop Gain	–	80	–	dB	
I _{SOA}	Amplifier Supply Current	–	10	30	μA	

a. Atypical behavior: I_{EBOA} of Port 0 Pin 0 is below 1 nA at 25°C; 50 nA over temperature. Use Port 0 Pins 1-7 for the lowest leakage of 200 nA.

Table 19. 2.7V DC Operational Amplifier Specifications

Symbol	Description	Min	Typ	Max	Units	Notes
V _{OSOA}	Input Offset Voltage (absolute value)	–	2.5	15	mV	
TCV _{OSOA}	Average Input Offset Voltage Drift	–	10	–	μV/°C	
I _{EBOA} ^a	Input Leakage Current (Port 0 Analog Pins)	–	200	–	pA	Gross tested to 1 μA.
C _{INOA}	Input Capacitance (Port 0 Analog Pins)	–	4.5	9.5	pF	Package and pin dependent. Temp = 25°C.

Table 19. 2.7V DC Operational Amplifier Specifications (continued)

Symbol	Description	Min	Typ	Max	Units	Notes
V _{CMOA}	Common Mode Voltage Range	0	–	V _{dd} - 1	V	
G _{OLOA}	Open Loop Gain	–	80	–	dB	
I _{SOA}	Amplifier Supply Current	–	10	30	μA	

a. Atypical behavior: I_{EBOA} of Port 0 Pin 0 is below 1 nA at 25°C; 50 nA over temperature. Use Port 0 Pins 1-7 for the lowest leakage of 200 nA.

DC Low Power Comparator Specifications

Table 20 lists the guaranteed maximum and minimum specifications for the voltage and temperature ranges: 4.75V to 5.25V and -40°C ≤ T_A ≤ 85°C, 3.0V to 3.6V and -40°C ≤ T_A ≤ 85°C, or 2.4V to 3.0V and -40°C ≤ T_A ≤ 85°C, respectively. Typical parameters apply to 5V at 25°C and are for design guidance only.

Table 20. DC Low Power Comparator Specifications

Symbol	Description	Min	Typ	Max	Units	Notes
V _{REFLPC}	Low power comparator (LPC) reference voltage range	0.2	–	V _{dd} - 1	V	
I _{SLPC}	LPC supply current	–	10	40	μA	
V _{OSLPC}	LPC voltage offset	–	2.5	30	mV	

DC Switch Mode Pump Specifications

Table 21 lists the guaranteed maximum and minimum specifications for the voltage and temperature ranges: 4.75V to 5.25V and -40°C ≤ T_A ≤ 85°C, 3.0V to 3.6V and -40°C ≤ T_A ≤ 85°C, or 2.4V to 3.0V and -40°C ≤ T_A ≤ 85°C, respectively. Typical parameters apply to 5V, 3.3V, or 2.7V at 25°C and are for design guidance only.

Table 21. DC Switch Mode Pump (SMP) Specifications

Symbol	Description	Min	Typ	Max	Units	Notes
V _{PUMP5V}	5V Output Voltage from Pump	4.75	5.0	5.25	V	Configuration of footnote. ^a Average, neglecting ripple. SMP trip voltage is set to 5.0V.
V _{PUMP3V}	3.3V Output Voltage from Pump	3.00	3.25	3.60	V	Configuration of footnote. ^a Average, neglecting ripple. SMP trip voltage is set to 3.25V.
V _{PUMP2V}	2.6V Output Voltage from Pump	2.45	2.55	2.80	V	Configuration of footnote. ^a Average, neglecting ripple. SMP trip voltage is set to 2.55V.
I _{PUMP}	Available Output Current V _{BAT} = 1.8V, V _{PUMP} = 5.0V V _{BAT} = 1.5V, V _{PUMP} = 3.25V V _{BAT} = 1.3V, V _{PUMP} = 2.55V	5 8 8	– – –	– – –	mA mA mA	Configuration of footnote. ^a SMP trip voltage is set to 5.0V. SMP trip voltage is set to 3.25V. SMP trip voltage is set to 2.55V.
V _{BAT5V}	Input Voltage Range from Battery	1.8	–	5.0	V	Configuration of footnote. ^a SMP trip voltage is set to 5.0V.
V _{BAT3V}	Input Voltage Range from Battery	1.0	–	3.3	V	Configuration of footnote. ^a SMP trip voltage is set to 3.25V.
V _{BAT2V}	Input Voltage Range from Battery	1.0	–	2.8	V	Configuration of footnote. ^a SMP trip voltage is set to 2.55V.
V _{BATSTART}	Minimum Input Voltage from Battery to Start Pump	1.2	–	–	V	Configuration of footnote. ^a 0°C ≤ T _A ≤ 100. 1.25V at T _A = -40°C.
ΔV _{PUMP_Line}	Line Regulation (over V _i range)	–	5	–	%V _O	Configuration of footnote. ^a V _O is the “V _{dd} Value for PUMP Trip” specified by the VM[2:0] setting in the DC POR and LVD Specification, Table 23 on page 24.

Table 21. DC Switch Mode Pump (SMP) Specifications (continued)

Symbol	Description	Min	Typ	Max	Units	Notes
ΔV_{PUMP_Load}	Load Regulation	–	5	–	% V_O	Configuration of footnote. ^a V_O is the “Vdd Value for PUMP Trip” specified by the VM[2:0] setting in the DC POR and LVD Specification, Table 23 on page 24.
ΔV_{PUMP_Ripple}	Output Voltage Ripple (depends on cap/load)	–	100	–	mVpp	Configuration of footnote. ^a Load is 5 mA.
E_3	Efficiency	35	50	–	%	Configuration of footnote. ^a Load is 5 mA. SMP trip voltage is set to 3.25V.
E_2	Efficiency	35	80	–	%	For I load = 1mA, $V_{PUMP} = 2.55V$, $V_{BAT} = 1.3V$, 10 uH inductor, 1 uF capacitor, and Schottky diode.
F_{PUMP}	Switching Frequency	–	1.3	–	MHz	
DC_{PUMP}	Switching Duty Cycle	–	50	–	%	

a. $L_1 = 2$ mH inductor, $C_1 = 10$ mF capacitor, $D_1 =$ Schottky diode. See Figure 15.

Figure 15. Basic Switch Mode Pump Circuit

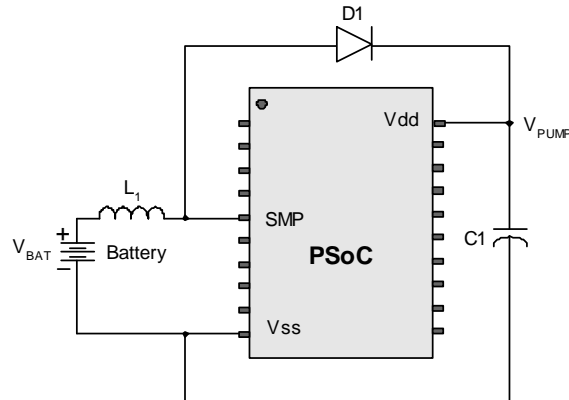

DC Analog Mux Bus Specifications

Table 22 lists the guaranteed maximum and minimum specifications for the voltage and temperature ranges: 4.75V to 5.25V and $-40^{\circ}\text{C} \leq T_A \leq 85^{\circ}\text{C}$, 3.0V to 3.6V and $-40^{\circ}\text{C} \leq T_A \leq 85^{\circ}\text{C}$, or 2.4V to 3.0V and $-40^{\circ}\text{C} \leq T_A \leq 85^{\circ}\text{C}$, respectively. Typical parameters apply to 5V, 3.3V, or 2.7V at 25°C and are for design guidance only.

Table 22. DC Analog Mux Bus Specifications

Symbol	Description	Min	Typ	Max	Units	Notes
R _{SW}	Switch Resistance to Common Analog Bus	–	–	400	W	V _{dd} ≥ 2.7V
				800	W	2.4V ≤ V _{dd} ≤ 2.7V
R _{VDD}	Resistance of Initialization Switch to V _{dd}	–	–	800	W	

DC POR and LVD Specifications

Table 23 lists the guaranteed maximum and minimum specifications for the voltage and temperature ranges: 4.75V to 5.25V and $-40^{\circ}\text{C} \leq T_A \leq 85^{\circ}\text{C}$, 3.0V to 3.6V and $-40^{\circ}\text{C} \leq T_A \leq 85^{\circ}\text{C}$, or 2.4V to 3.0V and $-40^{\circ}\text{C} \leq T_A \leq 85^{\circ}\text{C}$, respectively. Typical parameters apply to 5V, 3.3V, or 2.7V at 25°C and are for design guidance only.

Table 23. DC POR and LVD Specifications

Symbol	Description	Min	Typ	Max	Units	Notes
V _{PPOR0} V _{PPOR1} V _{PPOR2}	V _{dd} Value for PPOR Trip	–	2.36	2.40	V	V _{dd} must be greater than or equal to 2.5V during startup, reset from the XRES pin, or reset from Watchdog.
	PORLEV[1:0] = 00b					
	PORLEV[1:0] = 01b					
V _{LVD0} V _{LVD1} V _{LVD2} V _{LVD3} V _{LVD4} V _{LVD5} V _{LVD6} V _{LVD7}	V _{dd} Value for LVD Trip	2.40	2.45	2.51 ^a	V	
	VM[2:0] = 000b					
	VM[2:0] = 001b					
	VM[2:0] = 010b					
	VM[2:0] = 011b					
	VM[2:0] = 100b					
	VM[2:0] = 101b					
	VM[2:0] = 110b					
VM[2:0] = 111b						
V _{PUMP0} V _{PUMP1} V _{PUMP2} V _{PUMP3} V _{PUMP4} V _{PUMP5} V _{PUMP6} V _{PUMP7}	V _{dd} Value for PUMP Trip	2.45	2.55	2.62 ^c	V	
	VM[2:0] = 000b					
	VM[2:0] = 001b					
	VM[2:0] = 010b					
	VM[2:0] = 011b					
	VM[2:0] = 100b					
	VM[2:0] = 101b					
	VM[2:0] = 110b					
VM[2:0] = 111b						

- a. Always greater than 50 mV above V_{PPOR} (PORLEV = 00) for falling supply.
- b. Always greater than 50 mV above V_{PPOR} (PORLEV = 01) for falling supply.
- c. Always greater than 50 mV above V_{LVD0}.
- d. Always greater than 50 mV above V_{LVD3}.

DC Programming Specifications

Table 24 lists the guaranteed maximum and minimum specifications for the voltage and temperature ranges: 4.75V to 5.25V and $-40^{\circ}\text{C} \leq T_A \leq 85^{\circ}\text{C}$, 3.0V to 3.6V and $-40^{\circ}\text{C} \leq T_A \leq 85^{\circ}\text{C}$, or 2.4V to 3.0V and $-40^{\circ}\text{C} \leq T_A \leq 85^{\circ}\text{C}$, respectively. Typical parameters apply to 5V, 3.3V, or 2.7V at 25°C and are for design guidance only.

Table 24. DC Programming Specifications

Symbol	Description	Min	Typ	Max	Units	Notes
V _{DDIWRIT} E	Supply Voltage for Flash Write Operations	2.70	–	–	V	
I _{DDP}	Supply Current During Programming or Verify	–	5	25	mA	
V _{ILP}	Input Low Voltage During Programming or Verify	–	–	0.8	V	
V _{IHP}	Input High Voltage During Programming or Verify	2.2	–	–	V	
I _{ILP}	Input Current when Applying V _{ilp} to P1[0] or P1[1] During Programming or Verify	–	–	0.2	mA	Driving internal pull down resistor.
I _{IHP}	Input Current when Applying V _{ihp} to P1[0] or P1[1] During Programming or Verify	–	–	1.5	mA	Driving internal pull down resistor.
V _{OLV}	Output Low Voltage During Programming or Verify	–	–	V _{SS} + 0.75	V	
V _{OHV}	Output High Voltage During Programming or Verify	V _{DD} - 1.0	–	V _{DD}	V	
Flash _{ENP} B	Flash Endurance (per block)	50,000	–	–	–	Erase/write cycles per block.
Flash _{ENT}	Flash Endurance (total) ^a	1,800,000	–	–	–	Erase/write cycles.
Flash _{DR}	Flash Data Retention	10	–	–	Years	

- a. A maximum of 36 x 50,000 block endurance cycles is allowed. This may be balanced between operations on 36x1 blocks of 50,000 maximum cycles each, 36x2 blocks of 25,000 maximum cycles each, or 36x4 blocks of 12,500 maximum cycles each (to limit the total number of cycles to 36x50,000 and that no single block ever sees more than 50,000 cycles).
- b. For the full industrial range, the user must employ a temperature sensor user module (FlashTemp) and feed the result to the temperature argument before writing. Refer to the Flash APIs Application Note AN2015 at <http://www.cypress.com> under Application Notes for more information.

AC Electrical Characteristics

AC Chip-Level Specifications

The following tables list the guaranteed maximum and minimum specifications for the voltage and temperature ranges: 4.75V to 5.25V and $-40^{\circ}\text{C} \leq T_A \leq 85^{\circ}\text{C}$, 3.0V to 3.6V and $-40^{\circ}\text{C} \leq T_A \leq 85^{\circ}\text{C}$, or 2.4V to 3.0V and $-40^{\circ}\text{C} \leq T_A \leq 85^{\circ}\text{C}$, respectively. Typical parameters apply to 5V, 3.3V, or 2.7V at 25°C and are for design guidance only.

Table 25. 5V and 3.3V AC Chip-Level Specifications

Symbol	Description	Min	Typ	Max	Units	Notes
F _{IMO24}	Internal Main Oscillator Frequency for 24 MHz	23.4	24	24.6 ^{a,b,c}	MHz	Trimmed for 5V or 3.3V operation using factory trim values. See Figure 14 on page 18. SLIMO mode = 0.
F _{IMO6}	Internal Main Oscillator Frequency for 6 MHz	5.75	6	6.35 ^{a,b,c}	MHz	Trimmed for 5V or 3.3V operation using factory trim values. See Figure 14 on page 18. SLIMO mode = 1.
F _{CPU1}	CPU Frequency (5V Nominal)	0.93	24	24.6 ^{a,b}	MHz	24 MHz only for SLIMO mode = 0.
F _{CPU2}	CPU Frequency (3.3V Nominal)	0.93	12	12.3 ^{b,c}	MHz	
F _{BLK5}	Digital PSoC Block Frequency (5V Nominal)	0	48	49.2 ^{a,b,d}	MHz	Refer to the AC Digital Block Specifications.
F _{BLK33}	Digital PSoC Block Frequency (3.3V Nominal)	0	24	24.6 ^{b,d}	MHz	
F _{32K1}	Internal Low Speed Oscillator Frequency	15	32	64	kHz	
Jitter32k	32 kHz RMS Period Jitter	–	100	200	ns	
Jitter32k	32 kHz Peak-to-Peak Period Jitter	–	1400	–		
T _{XRST}	External Reset Pulse Width	10	–	–	μs	
DC24M	24 MHz Duty Cycle	40	50	60	%	
Step24M	24 MHz Trim Step Size	–	50	–	kHz	
Fout48M	48 MHz Output Frequency	46.8	48.0	49.2 ^{a,c}	MHz	Trimmed. Using factory trim values.
Jitter24M1	24 MHz Peak-to-Peak Period Jitter (IMO)	–	600		ps	
F _{MAX}	Maximum frequency of signal on row input or row output.	–	–	12.3	MHz	
T _{RAMP}	Supply Ramp Time	0	–	–	μs	

a. 4.75V < Vdd < 5.25V.

b. Accuracy derived from Internal Main Oscillator with appropriate trim for Vdd range.

c. 3.0V < Vdd < 3.6V. See Application Note [AN2012](#) “Adjusting PSoC Microcontroller Trims for Dual Voltage-Range Operation” for information on trimming for operation at 3.3V.

d. See the individual user module data sheets for information on maximum frequencies for user modules.

Table 26. 2.7V AC Chip-Level Specifications

Symbol	Description	Min	Typ	Max	Units	Notes
F _{IMO12}	Internal Main Oscillator Frequency for 12 MHz	11.5	12	12.7 ^{a,b,c}	MHz	Trimmed for 2.7V operation using factory trim values. See Figure 14 on page 18. SLIMO mode = 1.
F _{IMO6}	Internal Main Oscillator Frequency for 6 MHz	5.75	6	6.35 ^{a,b,c}	MHz	Trimmed for 2.7V operation using factory trim values. See Figure 14 on page 18. SLIMO mode = 1.
F _{CPU1}	CPU Frequency (2.7V Nominal)	0.093	3	3.15 ^{a,b}	MHz	24 MHz only for SLIMO mode = 0.
F _{BLK27}	Digital PSoC Block Frequency (2.7V Nominal)	0	12	12.5 ^{a,b,c}	MHz	Refer to the AC Digital Block Specifications.
F _{32K1}	Internal Low Speed Oscillator Frequency	8	32	96	kHz	

Table 26. 2.7V AC Chip-Level Specifications (continued)

Symbol	Description	Min	Typ	Max	Units	Notes
Jitter32k	32 kHz RMS Period Jitter	–	150	200	ns	
Jitter32k	32 kHz Peak-to-Peak Period Jitter	–	1400	–		
T _{XRST}	External Reset Pulse Width	10	–	–	μs	
F _{MAX}	Maximum frequency of signal on row input or row output.	–	–	12.3	MHz	
T _{RAMP}	Supply Ramp Time	0	–	–	μs	

- a. 2.4V < V_{dd} < 3.0V.
- b. Accuracy derived from Internal Main Oscillator with appropriate trim for V_{dd} range.
- c. See Application Note AN2012 “Adjusting PSoC Microcontroller Trims for Dual Voltage-Range Operation” for information on maximum frequency for user modules.

Figure 16. 24 MHz Period Jitter (IMO) Timing Diagram



Figure 17. 32 kHz Period Jitter (ILO) Timing Diagram

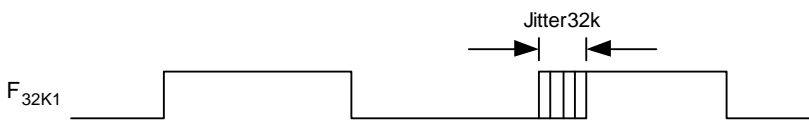

AC General Purpose IO Specifications

The following tables list the guaranteed maximum and minimum specifications for the voltage and temperature ranges: 4.75V to 5.25V and -40°C ≤ T_A ≤ 85°C, 3.0V to 3.6V and -40°C ≤ T_A ≤ 85°C, or 2.4V to 3.0V and -40°C ≤ T_A ≤ 85°C, respectively. Typical parameters apply to 5V, 3.3V, or 2.7V at 25°C and are for design guidance only.

Table 27. 5V and 3.3V AC GPIO Specifications

Symbol	Description	Min	Typ	Max	Units	Notes
F _{GPIO}	GPIO Operating Frequency	0	–	12	MHz	Normal Strong Mode
TRiseF	Rise Time, Normal Strong Mode, Cload = 50 pF	3	–	18	ns	V _{dd} = 4.5 to 5.25V, 10% - 90%
TFallF	Fall Time, Normal Strong Mode, Cload = 50 pF	2	–	18	ns	V _{dd} = 4.5 to 5.25V, 10% - 90%
TRiseS	Rise Time, Slow Strong Mode, Cload = 50 pF	7	27	–	ns	V _{dd} = 3 to 5.25V, 10% - 90%
TFallS	Fall Time, Slow Strong Mode, Cload = 50 pF	7	22	–	ns	V _{dd} = 3 to 5.25V, 10% - 90%

Table 28. 2.7V AC GPIO Specifications

Symbol	Description	Min	Typ	Max	Units	Notes
F _{GPIO}	GPIO Operating Frequency	0	–	3	MHz	Normal Strong Mode
TRiseF	Rise Time, Normal Strong Mode, Cload = 50 pF	6	–	50	ns	V _{dd} = 2.4 to 3.0V, 10% - 90%
TFallF	Fall Time, Normal Strong Mode, Cload = 50 pF	6	–	50	ns	V _{dd} = 2.4 to 3.0V, 10% - 90%
TRiseS	Rise Time, Slow Strong Mode, Cload = 50 pF	18	40	120	ns	V _{dd} = 2.4 to 3.0V, 10% - 90%
TFallS	Fall Time, Slow Strong Mode, Cload = 50 pF	18	40	120	ns	V _{dd} = 2.4 to 3.0V, 10% - 90%

Figure 18. GPIO Timing Diagram

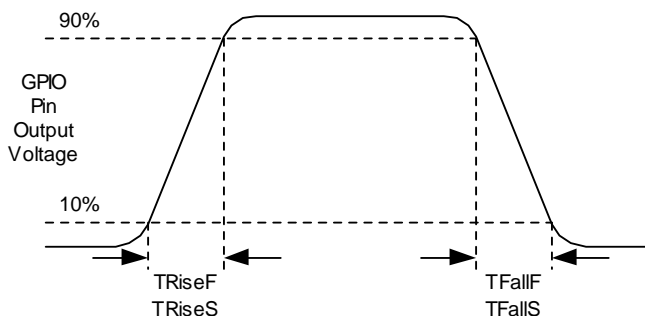

AC Operational Amplifier Specifications

Table 29 lists the guaranteed maximum and minimum specifications for the voltage and temperature ranges: 4.75V to 5.25V and $-40^{\circ}\text{C} \leq T_A \leq 85^{\circ}\text{C}$, 3.0V to 3.6V and $-40^{\circ}\text{C} \leq T_A \leq 85^{\circ}\text{C}$, or 2.4V to 3.0V and $-40^{\circ}\text{C} \leq T_A \leq 85^{\circ}\text{C}$, respectively. Typical parameters apply to 5V, 3.3V, or 2.7V at 25°C and are for design guidance only.

Table 29. AC Operational Amplifier Specifications

Symbol	Description	Min	Typ	Max	Units	Notes
T_{COMP}	Comparator Mode Response Time, 50 mV Overdrive			100 200	ns ns	$V_{\text{dd}} \geq 3.0\text{V}$. $2.4\text{V} < V_{\text{cc}} < 3.0\text{V}$.

AC Low Power Comparator Specifications

Table 30 lists the guaranteed maximum and minimum specifications for the voltage and temperature ranges: 4.75V to 5.25V and $-40^{\circ}\text{C} \leq T_A \leq 85^{\circ}\text{C}$, 3.0V to 3.6V and $-40^{\circ}\text{C} \leq T_A \leq 85^{\circ}\text{C}$, or 2.4V to 3.0V and $-40^{\circ}\text{C} \leq T_A \leq 85^{\circ}\text{C}$, respectively. Typical parameters apply to 5V at 25°C and are for design guidance only.

Table 30. AC Low Power Comparator Specifications

Symbol	Description	Min	Typ	Max	Units	Notes
T_{RLPC}	LPC response time	–	–	50	μs	≥ 50 mV overdrive comparator reference set within V_{REFLPC} .

AC Analog Mux Bus Specifications

Table 31 lists the guaranteed maximum and minimum specifications for the voltage and temperature ranges: 4.75V to 5.25V and $-40^{\circ}\text{C} \leq T_A \leq 85^{\circ}\text{C}$, 3.0V to 3.6V and $-40^{\circ}\text{C} \leq T_A \leq 85^{\circ}\text{C}$, or 2.4V to 3.0V and $-40^{\circ}\text{C} \leq T_A \leq 85^{\circ}\text{C}$, respectively. Typical parameters apply to 5V, 3.3V, or 2.7V at 25°C and are for design guidance only.

Table 31. AC Analog Mux Bus Specifications

Symbol	Description	Min	Typ	Max	Units	Notes
F_{SW}	Switch Rate	–	–	3.17	MHz	

AC Digital Block Specifications

The following tables list the guaranteed maximum and minimum specifications for the voltage and temperature ranges: 4.75V to 5.25V and $-40^{\circ}\text{C} \leq T_A \leq 85^{\circ}\text{C}$, 3.0V to 3.6V and $-40^{\circ}\text{C} \leq T_A \leq 85^{\circ}\text{C}$, or 2.4V to 3.0V and $-40^{\circ}\text{C} \leq T_A \leq 85^{\circ}\text{C}$, respectively. Typical parameters apply to 5V, 3.3V, or 2.7V at 25°C and are for design guidance only.

Table 32. 5V and 3.3V AC Digital Block Specifications

Function	Description	Min	Typ	Max	Units	Notes
All Functions	Maximum Block Clocking Frequency (> 4.75V)			49.2	MHz	4.75V < Vdd < 5.25V.
	Maximum Block Clocking Frequency (< 4.75V)			24.6	MHz	3.0V < Vdd < 4.75V.
Timer	Capture Pulse Width	50 ^a	–	–	ns	
	Maximum Frequency, No Capture	–	–	49.2	MHz	4.75V < Vdd < 5.25V.
	Maximum Frequency, With or Without Capture	–	–	24.6	MHz	
Counter	Enable Pulse Width	50	–	–	ns	
	Maximum Frequency, No Enable Input	–	–	49.2	MHz	4.75V < Vdd < 5.25V.
	Maximum Frequency, Enable Input	–	–	24.6	MHz	
Dead Band	Kill Pulse Width:					
	Asynchronous Restart Mode	20	–	–	ns	
	Synchronous Restart Mode	50	–	–	ns	
	Disable Mode	50	–	–	ns	
	Maximum Frequency	–	–	49.2	MHz	4.75V < Vdd < 5.25V.
CRCPRS (PRS Mode)	Maximum Input Clock Frequency	–	–	49.2	MHz	4.75V < Vdd < 5.25V.
CRCPRS (CRC Mode)	Maximum Input Clock Frequency	–	–	24.6	MHz	
SPIM	Maximum Input Clock Frequency	–	–	8.2	MHz	Maximum data rate at 4.1 MHz due to 2 x over clocking.
SPIS	Maximum Input Clock Frequency	–	–	4.1	MHz	
	Width of SS_ Negated Between Transmissions	50	–	–	ns	
Transmitter	Maximum Input Clock Frequency	–	–	24.6	MHz	Maximum data rate at 3.08 MHz due to 8 x over clocking.
	Maximum Input Clock Frequency with Vdd ≥ 4.75V, 2 Stop Bits	–	–	49.2	MHz	Maximum data rate at 6.15 MHz due to 8 x over clocking.
Receiver	Maximum Input Clock Frequency	–	–	24.6	MHz	Maximum data rate at 3.08 MHz due to 8 x over clocking.
	Maximum Input Clock Frequency with Vdd ≥ 4.75V, 2 Stop Bits	–	–	49.2	MHz	Maximum data rate at 6.15 MHz due to 8 x over clocking.

a. 50 ns minimum input pulse width is based on the input synchronizers running at 12 MHz (84 ns nominal period).

Table 33. 2.7V AC Digital Block Specifications

Function	Description	Min	Typ	Max	Units	Notes
All Functions	Maximum Block Clocking Frequency			12.7	MHz	2.4V < Vdd < 3.0V.
Timer	Capture Pulse Width	100 ^a	–	–	ns	
	Maximum Frequency, With or Without Capture	–	–	12.7	MHz	
Counter	Enable Pulse Width	100	–	–	ns	
	Maximum Frequency, No Enable Input	–	–	12.7	MHz	
	Maximum Frequency, Enable Input	–	–	12.7	MHz	
Dead Band	Kill Pulse Width:					
	Asynchronous Restart Mode	20	–	–	ns	
	Synchronous Restart Mode	100	–	–	ns	
	Disable Mode	100	–	–	ns	
CRCPRS (PRS Mode)	Maximum Input Clock Frequency	–	–	12.7	MHz	
	Maximum Input Clock Frequency	–	–	12.7	MHz	
SPIM	Maximum Input Clock Frequency	–	–	6.35	MHz	Maximum data rate at 3.17 MHz due to 2 x over clocking.
	Width of SS_ Negated Between Transmissions	100	–	–	ns	
SPIS	Maximum Input Clock Frequency	–	–	4.1	MHz	
	Maximum Input Clock Frequency	–	–	12.7	MHz	Maximum data rate at 1.59 MHz due to 8 x over clocking.
Receiver	Maximum Input Clock Frequency	–	–	12.7	MHz	Maximum data rate at 1.59 MHz due to 8 x over clocking.

a. 100 ns minimum input pulse width is based on the input synchronizers running at 12 MHz (84 ns nominal period).

AC External Clock Specifications

The following tables list the guaranteed maximum and minimum specifications for the voltage and temperature ranges: 4.75V to 5.25V and $-40^{\circ}\text{C} \leq T_A \leq 85^{\circ}\text{C}$, or 3.0V to 3.6V and $-40^{\circ}\text{C} \leq T_A \leq 85^{\circ}\text{C}$, respectively. Typical parameters apply to 5V, 3.3V, or 2.7V at 25°C and are for design guidance only.

Table 34. 5V AC External Clock Specifications

Symbol	Description	Min	Typ	Max	Units
F _{OSCEXT}	Frequency	0.093	–	24.6	MHz
–	High Period	20.6	–	5300	ns
–	Low Period	20.6	–	–	ns
–	Power Up IMO to Switch	150	–	–	μs

Table 35. 3.3V AC External Clock Specifications

Symbol	Description	Min	Typ	Max	Units	Notes
F _{OSCEXT}	Frequency with CPU Clock divide by 1	0.093	–	12.3	MHz	Maximum CPU frequency is 12 MHz at 3.3V. With the CPU clock divider set to 1, the external clock must adhere to the maximum frequency and duty cycle requirements.
F _{OSCEXT}	Frequency with CPU Clock divide by 2 or greater	0.186	–	24.6	MHz	If the frequency of the external clock is greater than 12 MHz, the CPU clock divider must be set to 2 or greater. In this case, the CPU clock divider ensures that the fifty percent duty cycle requirement is met.
–	High Period with CPU Clock divide by 1	41.7	–	5300	ns	
–	Low Period with CPU Clock divide by 1	41.7	–	–	ns	
–	Power Up IMO to Switch	150	–	–	μs	

Table 36. 2.7V AC External Clock Specifications

Symbol	Description	Min	Typ	Max	Units	Notes
F _{OSCEXT}	Frequency with CPU Clock divide by 1	0.093	–	3.08	MHz	Maximum CPU frequency is 3 MHz at 2.7V. With the CPU clock divider set to 1, the external clock must adhere to the maximum frequency and duty cycle requirements.
F _{OSCEXT}	Frequency with CPU Clock divide by 2 or greater	0.186	–	6.35	MHz	If the frequency of the external clock is greater than 3 MHz, the CPU clock divider must be set to 2 or greater. In this case, the CPU clock divider ensures that the fifty percent duty cycle requirement is met.
–	High Period with CPU Clock divide by 1	160	–	5300	ns	
–	Low Period with CPU Clock divide by 1	160	–	–	ns	
–	Power Up IMO to Switch	150	–	–	μs	

AC Programming Specifications

Table 37 lists the guaranteed maximum and minimum specifications for the voltage and temperature ranges: 4.75V to 5.25V and -40°C ≤ T_A ≤ 85°C, or 3.0V to 3.6V and -40°C ≤ T_A ≤ 85°C, respectively. Typical parameters apply to 5V, 3.3V, or 2.7V at 25°C and are for design guidance only.

Table 37. AC Programming Specifications

Symbol	Description	Min	Typ	Max	Units	Notes
T _{RSCLK}	Rise Time of SCLK	1	–	20	ns	
T _{FSCLK}	Fall Time of SCLK	1	–	20	ns	
T _{SSCLK}	Data Set up Time to Falling Edge of SCLK	40	–	–	ns	
T _{HSCLK}	Data Hold Time from Falling Edge of SCLK	40	–	–	ns	
F _{SCLK}	Frequency of SCLK	0	–	8	MHz	
T _{ERASEB}	Flash Erase Time (Block)	–	15	–	ms	

Table 37. AC Programming Specifications (continued)

Symbol	Description	Min	Typ	Max	Units	Notes
T _{WRITE}	Flash Block Write Time	–	30	–	ms	
T _{DSCLK}	Data Out Delay from Falling Edge of SCLK	–	–	45	ns	3.6 < V _{dd}
T _{DSCLK3}	Data Out Delay from Falling Edge of SCLK	–	–	50	ns	3.0 ≤ V _{dd} ≤ 3.6
T _{DSCLK2}	Data Out Delay from Falling Edge of SCLK	–	–	70	ns	2.4 ≤ V _{dd} ≤ 3.0

AC I²C Specifications

The following tables list the guaranteed maximum and minimum specifications for the voltage and temperature ranges: 4.75V to 5.25V and -40°C ≤ T_A ≤ 85°C, 3.0V to 3.6V and -40°C ≤ T_A ≤ 85°C, or 2.4V to 3.0V and -40°C ≤ T_A ≤ 85°C, respectively. Typical parameters apply to 5V, 3.3V, or 2.7V at 25°C and are for design guidance only.

Table 38. AC Characteristics of the I²C SDA and SCL Pins for V_{dd} ≥ 3.0V

Symbol	Description	Standard Mode		Fast Mode		Units
		Min	Max	Min	Max	
F _{SCL I2C}	SCL Clock Frequency	0	100	0	400	kHz
T _{HDSTA I2C}	Hold Time (repeated) START Condition. After this period, the first clock pulse is generated.	4.0	–	0.6	–	μs
T _{LOW I2C}	LOW Period of the SCL Clock	4.7	–	1.3	–	μs
T _{HIGH I2C}	HIGH Period of the SCL Clock	4.0	–	0.6	–	μs
T _{SUSTA I2C}	Set-up Time for a Repeated START Condition	4.7	–	0.6	–	μs
T _{HDDAT I2C}	Data Hold Time	0	–	0	–	μs
T _{SUDAT I2C}	Data Set-up Time	250	–	100 ^a	–	ns
T _{SUSTOI2C}	Set-up Time for STOP Condition	4.0	–	0.6	–	μs
T _{BUFI2C}	Bus Free Time Between a STOP and START Condition	4.7	–	1.3	–	μs
T _{SPI2C}	Pulse Width of spikes are suppressed by the input filter.	–	–	0	50	ns

- a. A Fast-Mode I2C-bus device may be used in a Standard-Mode I2C-bus system, but the requirement t_{SU;DAT} ≥ 250 ns must then be met. This is automatically the case if the device does not stretch the LOW period of the SCL signal. If such device does stretch the LOW period of the SCL signal, it must output the next data bit to the SDA line t_{rmax} + t_{SU;DAT} = 1000 + 250 = 1250 ns (according to the Standard-Mode I2C-bus specification) before the SCL line is released.

Table 39. 2.7V AC Characteristics of the I²C SDA and SCL Pins (Fast Mode not Supported)

Symbol	Description	Standard Mode		Fast Mode		Units
		Min	Max	Min	Max	
F _{SCL I2C}	SCL Clock Frequency	0	100	–	–	kHz
T _{HDSTA I2C}	Hold Time (repeated) START Condition. After this period, the first clock pulse is generated.	4.0	–	–	–	μs
T _{LOW I2C}	LOW Period of the SCL Clock	4.7	–	–	–	μs
T _{HIGH I2C}	HIGH Period of the SCL Clock	4.0	–	–	–	μs
T _{SUSTA I2C}	Set up Time for a Repeated START Condition	4.7	–	–	–	μs
T _{HDDAT I2C}	Data Hold Time	0	–	–	–	μs

Table 39. 2.7V AC Characteristics of the I²C SDA and SCL Pins (Fast Mode not Supported) (continued)

Symbol	Description	Standard Mode		Fast Mode		Units
		Min	Max	Min	Max	
T _{SUDAT12C}	Data Set-up Time	250	–	–	–	ns
T _{SUSTOI2C}	Set up Time for STOP Condition	4.0	–	–	–	μs
T _{BUF12C}	Bus Free Time Between a STOP and START Condition	4.7	–	–	–	μs
T _{SPI2C}	Pulse Width of spikes are suppressed by the input filter.	–	–	–	–	ns

Figure 19. Definition for Timing for Fast/Standard Mode on the I²C Bus

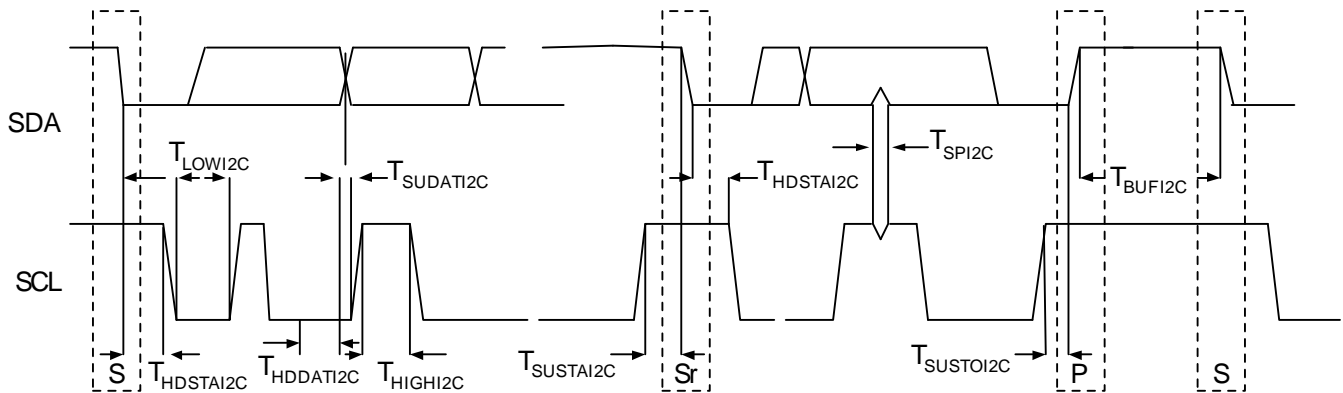

Packaging Information

This section shows the packaging specifications for the CY8C21x34 PSoC device with the thermal impedances for each package.

Important Note Emulation tools may require a larger area on the target PCB than the chip's footprint. For a detailed description of the emulation tools' dimensions, refer to the document titled *PSoC Emulator Pod Dimensions* at <http://www.cypress.com/design/MR10161>.

Packaging Dimensions

Figure 20. 16-Pin (150-Mil) SOIC

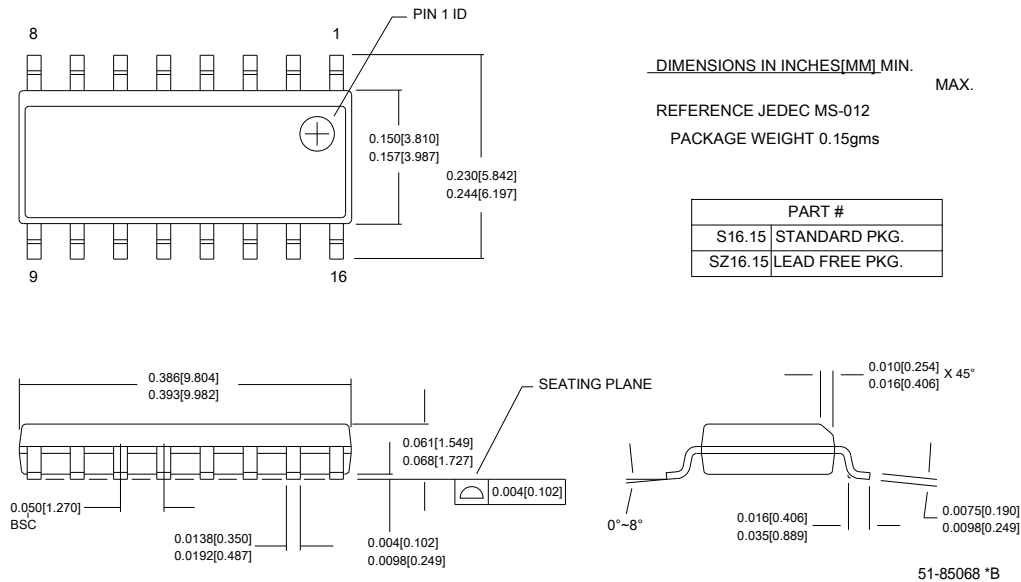

Figure 21. 20-Pin (210-MIL) SSOP

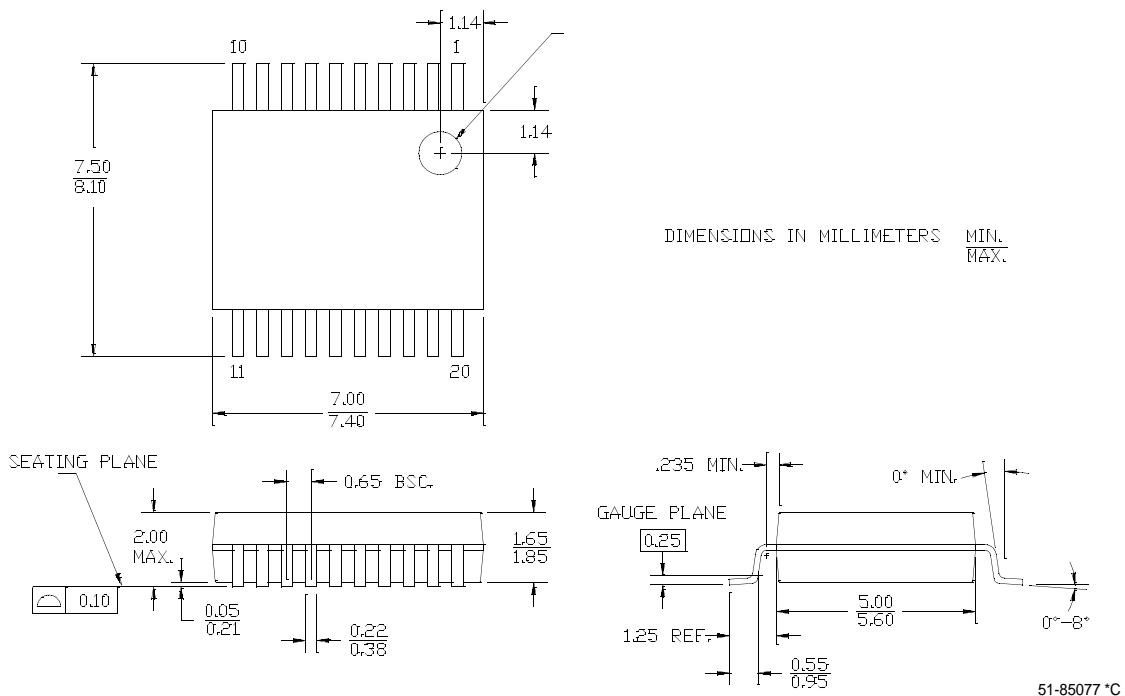

Figure 22. 28-Pin (210-Mil) SSOP

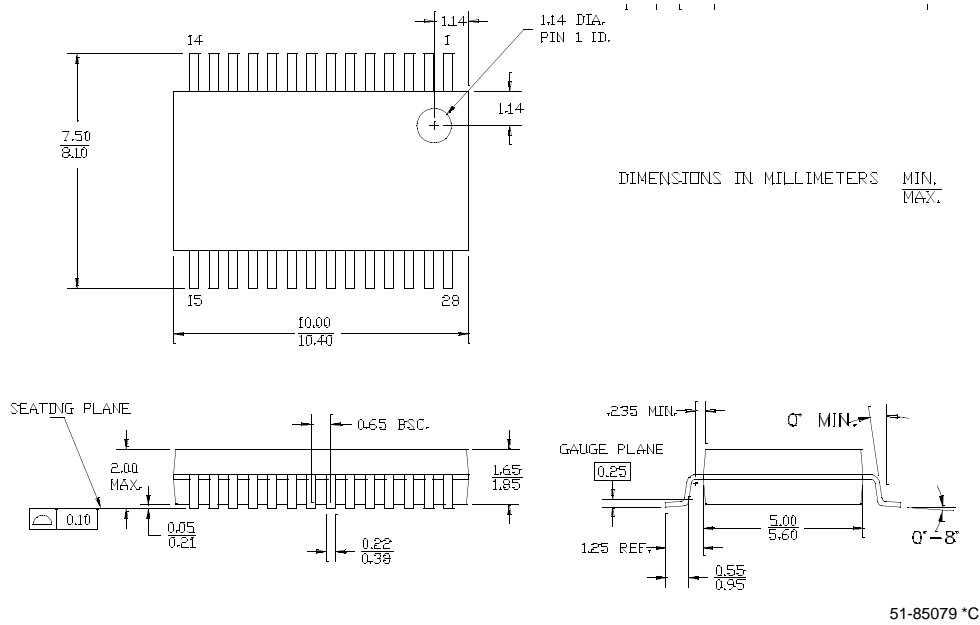
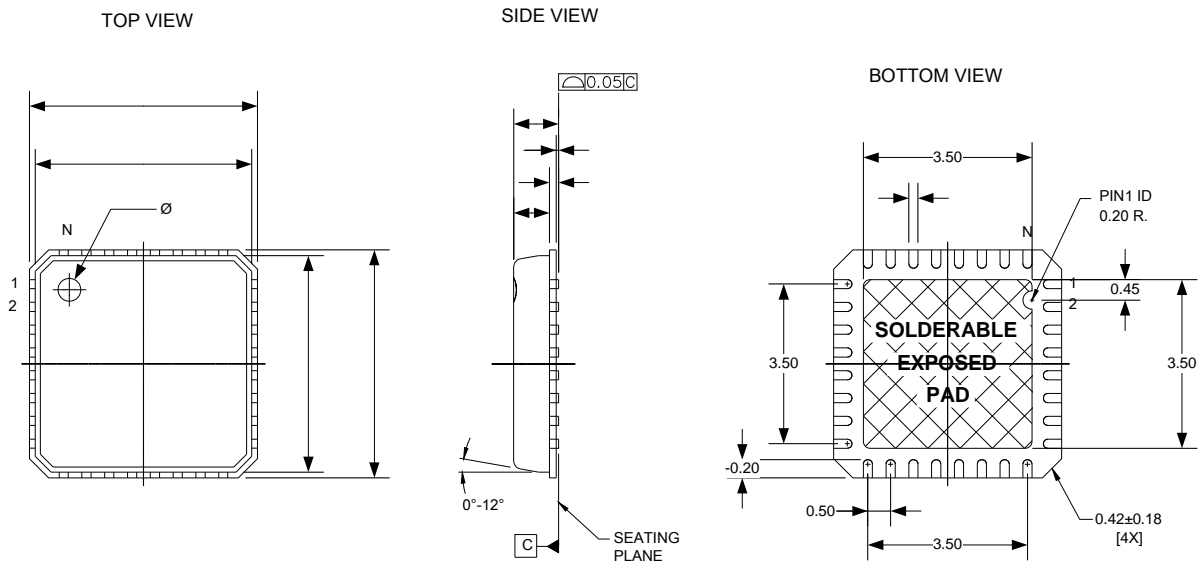
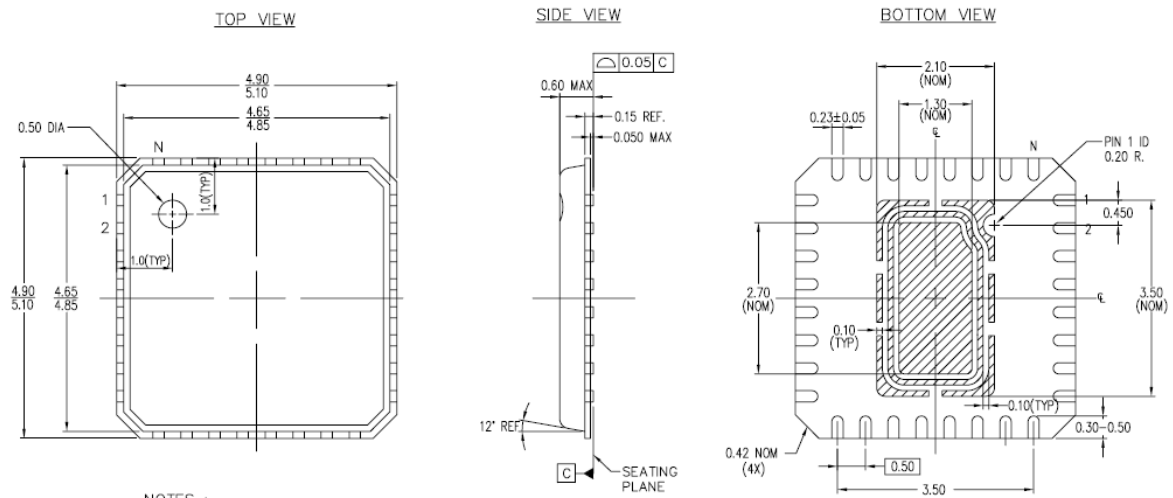

Figure 23. 32-Pin (5x5 mm 0.93 MAX) QFN



E-PAD X, Y for this product is 3.53 mm, 3.53 mm (+/-0.11 mm)

Figure 24. 32-Pin (5x5 mm 0.60 MAX) QFN



NOTES :

 HATCH AREA IS EXPOSED METAL

JEDEC # MO-220
DIMENSIONS IN mm MIN.
MAX.

UNIT PACKAGE WEIGHT : 0.0354 Grams

-PACKAGE CODE

PART NO.	DESCRIPTION
LJ32B	STANDARD
LK32B	PB-FREE

E-PAD X, Y for this product is 3.53 mm, 3.53 mm (+/-0.11 mm)

001-06392 *A

Important Note For information on the preferred dimensions for mounting QFN packages, see the following Application Note at http://www.amkor.com/products/notes_papers/MLFAppNote.pdf.

Figure 25. 32-Pin Sawn QFN Package

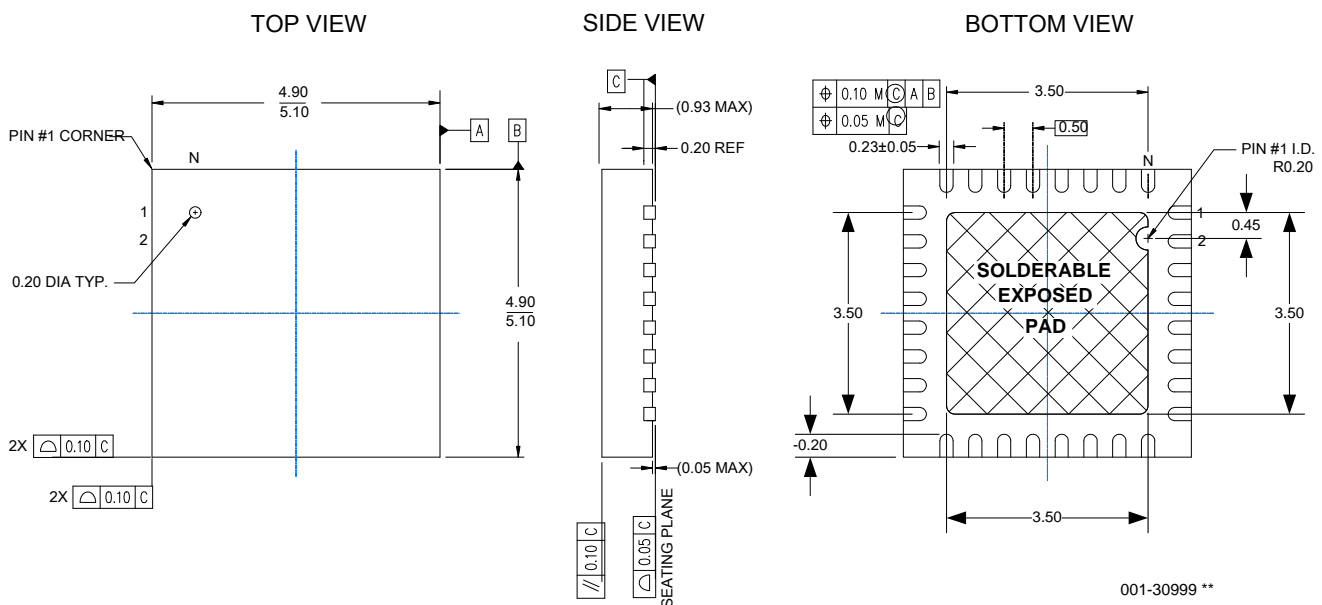

001-30999 **

Figure 26. 56-Pin (300-Mil) SSOP

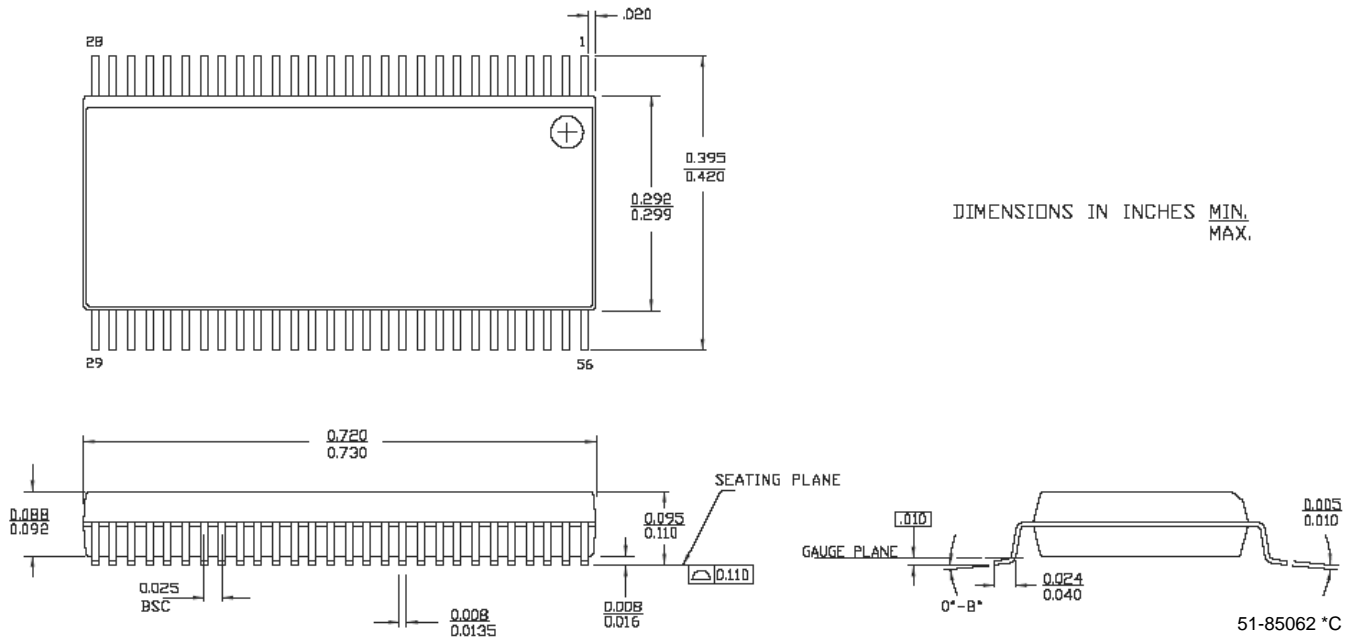

Thermal Impedances

Table 40. Thermal Impedances per Package

Package	Typical θ_{JA} *	Typical θ_{JC}
16 SOIC	123 °C/W	55 °C/W
20 SSOP	117 °C/W	41 °C/W
28 SSOP	96 °C/W	39 °C/W
32 QFN** 5x5 mm 0.60 MAX	27 °C/W	15 °C/W
32 QFN** 5x5 mm 0.93 MAX	22 °C/W	12 °C/W

* $T_J = T_A + \text{Power} \times \theta_{JA}$

** To achieve the thermal impedance specified for the QFN package, the center thermal pad must be soldered to the PCB ground plane.

Solder Reflow Peak Temperature

Following is the minimum solder reflow peak temperature to achieve good solderability.

Table 41. Solder Reflow Peak Temperature

Package	Minimum Peak Temperature*	Maximum Peak Temperature
16 SOIC	240°C	260°C
20 SSOP	240°C	260°C
28 SSOP	240°C	260°C
32 QFN	240°C	260°C

*Higher temperatures may be required based on the solder melting point. Typical temperatures for solder are 220 ± 5°C with Sn-Pb or 245 ± 5°C with Sn-Ag-Cu paste. Refer to the solder manufacturer specifications.

Development Tool Selection

This section presents the development tools available for all current PSoC device families including the CY8C21x34 family.

Software

PSoC Designer™

At the core of the PSoC development software suite is PSoC Designer. Used by thousands of PSoC developers, this robust software has been facilitating PSoC designs for half a decade. PSoC Designer is available free of charge at <http://www.cypress.com> under DESIGN RESOURCES >> Software and Drivers.

PSoC Express™

As the newest addition to the PSoC development software suite, PSoC Express is the first visual embedded system design tool that allows a user to create an entire PSoC project and generate a schematic, BOM, and data sheet without writing a single line of code. Users work directly with application objects such as LEDs, switches, sensors, and fans. PSoC Express is available free of charge at <http://www.cypress.com/psocexpress>.

PSoC Programmer

Flexible enough to be used on the bench in development, yet suitable for factory programming, PSoC Programmer works either as a standalone programming application or operates directly from PSoC Designer or PSoC Express. PSoC Programmer software is compatible with both PSoC ICE-Cube In-Circuit Emulator and PSoC MiniProg. PSoC programmer is available free of charge at <http://www.cypress.com/psocprogrammer>.

CY3202-C iMAGEcraft C Compiler

CY3202 is the optional upgrade to PSoC Designer that enables the iMAGEcraft C compiler. It can be purchased from the Cypress Online Store. At <http://www.cypress.com>, click the Online Store shopping cart icon at the bottom of the web page, and click *PSoC (Programmable System-on-Chip)* to view a current list of available items.

Development Kits

All development kits can be purchased from the Cypress Online Store.

CY3215-DK Basic Development Kit

The CY3215-DK is for prototyping and development with PSoC Designer. This kit supports in-circuit emulation and the software interface allows users to run, halt, and single step the processor and view the content of specific memory locations. Advance emulation features also supported through PSoC Designer. The kit includes:

- PSoC Designer Software CD
- ICE-Cube In-Circuit Emulator
- ICE Flex-Pod for CY8C29x66 Family
- Cat-5 Adapter

- Mini-Eval Programming Board
- 110 ~ 240V Power Supply, Euro-Plug Adapter
- iMAGEcraft C Compiler (Registration Required)
- ISSP Cable
- USB 2.0 Cable and Blue Cat-5 Cable
- 2 CY8C29466-24PXI 28-PDIP Chip Samples

CY3210-ExpressDK PSoC Express Development Kit

The CY3210-ExpressDK is for advanced prototyping and development with PSoC Express (may be used with ICE-Cube In-Circuit Emulator). It provides access to I²C buses, voltage reference, switches, upgradeable modules and more. The kit includes:

- PSoC Express Software CD
- Express Development Board
- 4 Fan Modules
- 2 Proto Modules
- MiniProg In-System Serial Programmer
- MiniEval PCB Evaluation Board
- Jumper Wire Kit
- USB 2.0 Cable
- Serial Cable (DB9)
- 110 ~ 240V Power Supply, Euro-Plug Adapter
- 2 CY8C24423A-24PXI 28-PDIP Chip Samples
- 2 CY8C27443-24PXI 28-PDIP Chip Samples
- 2 CY8C29466-24PXI 28-PDIP Chip Samples

Evaluation Tools

All evaluation tools can be purchased from the Cypress Online Store.

CY3210-MiniProg1

The CY3210-MiniProg1 kit allows a user to program PSoC devices through the MiniProg1 programming unit. The MiniProg is a small, compact prototyping programmer that connects to the PC through a provided USB 2.0 cable. The kit includes:

- MiniProg Programming Unit
- MiniEval Socket Programming and Evaluation Board
- 28-Pin CY8C29466-24PXI PDIP PSoC Device Sample
- 28-Pin CY8C27443-24PXI PDIP PSoC Device Sample
- PSoC Designer Software CD
- Getting Started Guide
- USB 2.0 Cable

CY3210-PSoCEval1

The CY3210-PSoCEval1 kit features an evaluation board and the MiniProg1 programming unit. The evaluation board includes an LCD module, potentiometer, LEDs, and plenty of bread-boarding space to meet all of your evaluation needs. The kit includes:

- Evaluation Board with LCD Module
- MiniProg Programming Unit
- 28-Pin CY8C29466-24PXI PDIP PSoC Device Sample (2)
- PSoC Designer Software CD
- Getting Started Guide
- USB 2.0 Cable

CY3214-PSoCEvalUSB

The CY3214-PSoCEvalUSB evaluation kit features a development board for the CY8C24794-24LFXI PSoC device. Special features of the board include both USB and capacitive sensing development and debugging support. This evaluation board also includes an LCD module, potentiometer, LEDs, an enunciator and plenty of bread boarding space to meet all of your evaluation needs. The kit includes:

- PSoCEvalUSB Board
- LCD Module
- MiniProg Programming Unit
- Mini USB Cable
- PSoC Designer and Example Projects CD
- Getting Started Guide
- Wire Pack

Accessories (Emulation and Programming)

Table 42. Emulation and Programming Accessories

Part #	Pin Package	Flex-Pod Kit ^a	Foot Kit ^b	Adapter
CY8C21234-24S	16 SOIC	CY3250-21X34	CY3250-16SOIC-FK	Programming adapter converts non-DIP package to DIP footprint. Specific details and ordering information for each of the adapters can be found at http://www.emulation.com .
CY8C21334-24PVXI	20 SSOP	CY3250-21X34	CY3250-20SSOP-FK	
CY8C21434-24LFXI	32 QFN	CY3250-21X34QFN	CY3250-32QFN-FK	
CY8C21534-24PVXI	28 SSOP	CY3250-21X34	CY3250-28SSOP-FK	
CY8C21634-24LFXI	32 QFN	CY3250-21X34QFN	CY3250-32QFN-FK	

a. Flex-Pod kit includes a practice flex-pod and a practice PCB, in addition to two flex-pods.

b. Foot kit includes surface mount feet that can be soldered to the target PCB.

3rd-Party Tools

Several tools have been specially designed by the following 3rd-party vendors to accompany PSoC devices during development and production. Specific details for each of these tools can be found at <http://www.cypress.com> under DESIGN RESOURCES >> Evaluation Boards.

Device Programmers

All device programmers can be purchased from the Cypress Online Store.

CY3216 Modular Programmer

The CY3216 Modular Programmer kit features a modular programmer and the MiniProg1 programming unit. The modular programmer includes three programming module cards and supports multiple Cypress products. The kit includes:

- Modular Programmer Base
- 3 Programming Module Cards
- MiniProg Programming Unit
- PSoC Designer Software CD
- Getting Started Guide
- USB 2.0 Cable

CY3207ISSP In-System Serial Programmer (ISSP)

The CY3207ISSP is a production programmer. It includes protection circuitry and an industrial case that is more robust than the MiniProg in a production-programming environment.

Note CY3207ISSP needs special software and is not compatible with PSoC Programmer. The kit includes:

- CY3207 Programmer Unit
- PSoC ISSP Software CD
- 110 ~ 240V Power Supply, Euro-Plug Adapter
- USB 2.0 Cable

Build a PSoC Emulator into Your Board

For details on how to emulate your circuit before going to volume production using an on-chip debug (OCD) non-production PSoC device, see Application Note [AN2323](#) "Debugging - Build a PSoC Emulator into Your Board".

Ordering Information

Package	Ordering Code	Flash (Bytes)	SRAM (Bytes)	Switch Mode Pump	Temperature Range	Digital Blocks	Analog Blocks	Digital IO Pins	Analog Inputs ^a	Analog Outputs	XRES Pin
16 Pin (150-Mil) SOIC	CY8C21234-24SXI	8K	512	Yes	-40°C to +85°C	4	4	12	12 ^a	0	No
16 Pin (150-Mil) SOIC (Tape and Reel)	CY8C21234-24SXIT	8K	512	Yes	-40°C to +85°C	4	4	12	12 ^a	0	No
20 Pin (210-Mil) SSOP	CY8C21334-24PVXI	8K	512	No	-40°C to +85°C	4	4	16	16 ^a	0	Yes
20 Pin (210-Mil) SSOP (Tape and Reel)	CY8C21334-24PVXIT	8K	512	No	-40°C to +85°C	4	4	16	16 ^a	0	Yes
28 Pin (210-Mil) SSOP	CY8C21534-24PVXI	8K	512	No	-40°C to +85°C	4	4	24	24 ^a	0	Yes
28 Pin (210-Mil) SSOP (Tape and Reel)	CY8C21534-24PVXIT	8K	512	No	-40°C to +85°C	4	4	24	24 ^a	0	Yes
32 Pin (5x5 mm 0.93 MAX) QFN ^b	CY8C21434-24LFXI	8K	512	No	-40°C to +85°C	4	4	28	28 ^a	0	Yes
32 Pin (5x5 mm 0.93 MAX) QFN ^b (Tape and Reel)	CY8C21434-24LFXIT	8K	512	No	-40°C to +85°C	4	4	28	28 ^a	0	Yes
32 Pin (5x5 mm 0.60 MAX) QFN ^b	CY8C21434-24LKXI	8K	512	No	-40°C to +85°C	4	4	28	28 ^a	0	Yes
32 Pin (5x5 mm 0.60 MAX) QFN ^b (Tape and Reel)	CY8C21434-24LKXIT	8K	512	No	-40°C to +85°C	4	4	28	28 ^a	0	Yes
32 Pin (5x5 mm 0.93 MAX) QFN ^b	CY8C21634-24LFXI	8K	512	Yes	-40°C to +85°C	4	4	26	26 ^a	0	Yes
32 Pin (5x5 mm 0.93 MAX) QFN ^b (Tape and Reel)	CY8C21634-24LFXIT	8K	512	Yes	-40°C to +85°C	4	4	26	26 ^a	0	Yes
32 Pin (5x5 mm 0.93 MAX) SAWN QFN	CY8C21434-24LTXI	8K	512	No	-40°C to +85°C	4	4	28	28 ^a	0	Yes
32 Pin (5x5 mm 0.93 MAX) SAWN QFN ^b (Tape and Reel)	CY8C21434-24LTXIT	8K	512	No	-40°C to +85°C	4	4	28	28 ^a	0	Yes
32 Pin (5x5 mm 0.93 MAX) SAWN QFN ^b	CY8C21634-24LTXI	8K	512	Yes	-40°C to +85°C	4	4	26	26 ^a	0	Yes
32 Pin (5x5 mm 0.93 MAX) SAWN QFN ^b (Tape and Reel)	CY8C21634-24LTXIT	8K	512	Yes	-40°C to +85°C	4	4	26	26 ^a	0	Yes
56 Pin OCD SSOP	CY8C21001-24PVXI	8K	512	Yes	-40°C to +85°C	4	4	26	26 ^a	0	Yes

a. All Digital IO Pins also connect to the common analog mux.

b. Refer to the section [32-Pin Part Pinout](#) on page 11 for pin differences.

Ordering Code Definitions

CY 8 C 21 xxx-24xx

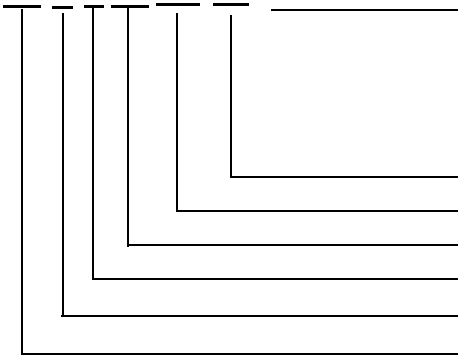

Package Type:
 PX = PDIP Pb-Free
 SX = SOIC Pb-Free
 PVX = SSOP Pb-Free
 LFX/LKX = QFN Pb-Free
 AX = TQFP Pb-Free

Thermal Rating:
 C = Commercial
 I = Industrial
 E = Extended

Speed: 24 MHz

Part Number

Family Code

Technology Code: C = CMOS

Marketing Code: 8 = Cypress PSoC

Company ID: CY = Cypress

Document History Page

Document Title: CY8C21234/CY8C21334/CY8C21434/CY8C21534/CY8C21634 PSoC [®] Mixed-Signal Array			
Document Number: 38-12025			
Revision	ECN	Orig. of Change	Description of Change
**	227340	HMT	New silicon and document (Revision **).
*A	235992	SFV	Updated Overview and Electrical Spec. chapters, along with revisions to the 24-pin pinout part. Revised the register mapping tables. Added a SSOP 28-pin part.
*B	248572	SFV	Changed title to include all part #s. Changed 28-pin SSOP from CY8C21434 to CY8C21534. Changed pin 9 on the 28-pin SSOP from SMP pin to Vss pin. Added SMP block to architecture diagram. Update Electrical Specifications. Added another 32-pin MLF part: CY8C21634.
*C	277832	HMT	Verify data sheet standards from SFV memo. Add Analog Input Mux to applicable pin outs. Update PSoC Characteristics table. Update diagrams and specs. Final.
*D	285293	HMT	Update 2.7V DC GPIO spec. Add Reflow Peak Temp. table.
*E	301739	HMT	DC Chip-Level Specification changes. Update links to new CY.com Portal.
*F	329104	HMT	Re-add pinout ISSP notation. Fix TMP register names. Clarify ADC feature. Update Electrical Specifications. Update Reflow Peak Temp. table. Add 32 MLF E-PAD dimensions. Add Theta _{JC} to Thermal Impedance table. Fix 20-pin package order number. Add CY logo. Update CY copyright.
*G	352736	HMT	Add new color and logo. Add URL to preferred dimensions for mounting MLF packages. Update Transmitter and Receiver AC Digital Block Electrical Specifications.
*H	390152	HMT	Clarify MLF thermal pad connection info. Replace 16-pin 300-MIL SOIC with correct 150-MIL.
*I	413404	HMT	Update 32-pin QFN E-Pad dimensions and rev. *A. Update CY branding and QFN convention.
*J	430185	HMT	Add new 32-pin 5x5 mm 0.60 thickness QFN package and diagram, CY8C21434-24LKXI. Update thermal resistance data. Add 56-pin SSOP on-chip debug non-production part, CY8C21001-24PVXI. Update typical and recommended Storage Temperature per industrial specs. Update copyright and trademarks.
*K	677717	HMT	Add CapSense SNR requirement reference. Add new Dev. Tool section. Add CY8C20x34 to PSoC Device Characteristics table. Add Low Power Comparator (LPC) AC/DC electrical spec. tables. Update rev. of 32-Lead (5x5 mm 0.60 MAX) QFN package diagram.
*L	2147847	UVS/PYRS	Added 32-Pin QFN Sawn pin diagram, package diagram, and ordering information.

© Cypress Semiconductor Corporation, 2004-2008. The information contained herein is subject to change without notice. Cypress Semiconductor Corporation assumes no responsibility for the use of any circuitry other than circuitry embodied in a Cypress product. Nor does it convey or imply any license under patent or other rights. Cypress products are not warranted nor intended to be used for medical, life support, life saving, critical control or safety applications, unless pursuant to an express written agreement with Cypress. Furthermore, Cypress does not authorize its products for use as critical components in life-support systems where a malfunction or failure may reasonably be expected to result in significant injury to the user. The inclusion of Cypress products in life-support systems application implies that the manufacturer assumes all risk of such use and in doing so indemnifies Cypress against all charges.

Any Source Code (software and/or firmware) is owned by Cypress Semiconductor Corporation (Cypress) and is protected by and subject to worldwide patent protection (United States and foreign), United States copyright laws and international treaty provisions. Cypress hereby grants to licensee a personal, non-exclusive, non-transferable license to copy, use, modify, create derivative works of, and compile the Cypress Source Code and derivative works for the sole purpose of creating custom software and/or firmware in support of licensee product to be used only in conjunction with a Cypress integrated circuit as specified in the applicable agreement. Any reproduction, modification, translation, compilation, or representation of this Source Code except as specified above is prohibited without the express written permission of Cypress.

Disclaimer: CYPRESS MAKES NO WARRANTY OF ANY KIND, EXPRESS OR IMPLIED, WITH REGARD TO THIS MATERIAL, INCLUDING, BUT NOT LIMITED TO, THE IMPLIED WARRANTIES OF MERCHANTABILITY AND FITNESS FOR A PARTICULAR PURPOSE. Cypress reserves the right to make changes without further notice to the materials described herein. Cypress does not assume any liability arising out of the application or use of any product or circuit described herein. Cypress does not authorize its products for use as critical components in life-support systems where a malfunction or failure may reasonably be expected to result in significant injury to the user. The inclusion of Cypress' product in a life-support systems application implies that the manufacturer assumes all risk of such use and in doing so indemnifies Cypress against all charges.

Use may be limited by and subject to the applicable Cypress software license agreement.