

5 - 50 MHz Channel Link II Serializer/Deserializer with LVDS Parallel Interface

General Description

The DS92LV0411 (serializer) and DS92LV0412 (deserializer) chipset translates a Channel Link LVDS video interface (4 LVDS Data + LVDS Clock) into a high-speed serialized interface over a single CML pair.

The DS92LV0411/DS92LV0412 enables applications that currently use the popular Channel Link or Channel Link style devices to seamlessly upgrade to an embedded clock interface to reduce interconnect cost or ease design challenges. The parallel LVDS interface also reduces FPGA I/O pins, board trace count and alleviates EMI issues, when compared to traditional single-ended wide bus interfaces.

Programmable transmit de-emphasis, receive equalization, on-chip scrambling and DC balancing enables longer distance transmission over lossy cables and backplanes. The Deserializer automatically locks to incoming data without an external reference clock or special sync patterns, providing easy "plug-and-go" operation.

The DS92LV0411 and DS92LV0412 are programmable through an I2C interface as well as by pins. A built-in AT-SPEED BIST feature validates link integrity and may be used for system diagnostics.

The DS92LV0411 and DS92LV0412 can be used interchangeably with the DS92LV2411 or DS92LV2412. This allows designers the flexibility to connect to the host device and receiving devices with different interface types, LVDS or LVC-MOS.

Features

- 5-channel (4 data + 1 clock) Channel Link LVDS parallel interface supports 24-bit data 3-bit control at 5 – 50 MHz
- AC Coupled STP Interconnect up to 10 meters in length
- Integrated serial CML terminations
- AT-SPEED BIST Mode and status pin
- Optional I2C compatible Serial Control Bus
- Power Down Mode minimizes power dissipation
- 1.8V or 3.3V compatible control pin interface
- >8 kV ESD (HBM) protection
- -40° to +85°C temperature range

SERIALIZER – DS92LV0411

- Data scrambler for reduced EMI
- DC-balance encoder for AC coupling
- Selectable output VOD and adjustable de-emphasis

DESERIALIZER – DS92LV0412

- Random data lock; no reference clock required
- Adjustable input receiver equalization
- EMI minimization on output parallel bus (Spread Spectrum Clock Generation and LVDS VOD select)

Applications

- Embedded Video and Display
- Machine Vision, Industrial Imaging, Medical Imaging
- Office Automation — Printers, Scanners, Copiers
- Security and Video Surveillance
- General purpose data communication

Applications Diagram

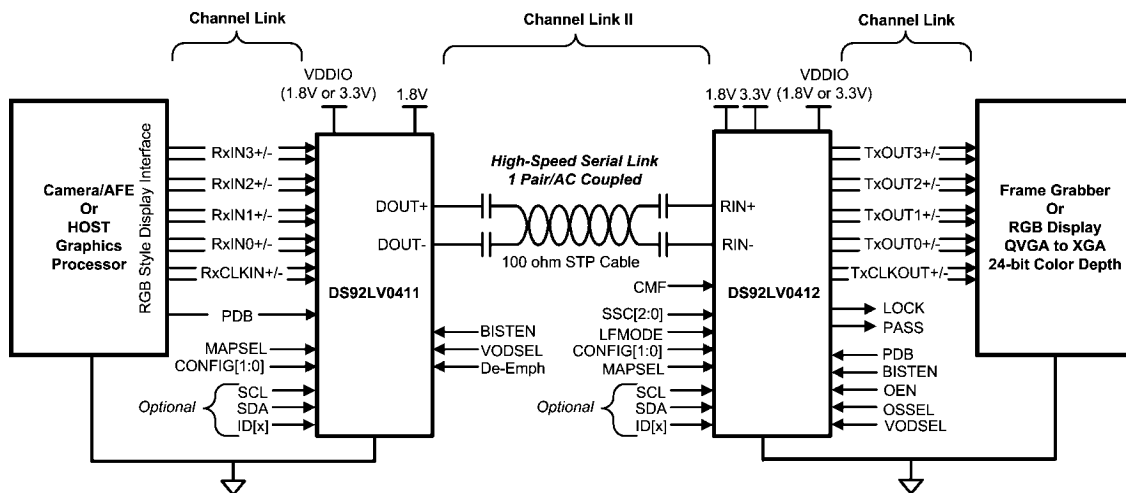

30125227

Block Diagrams

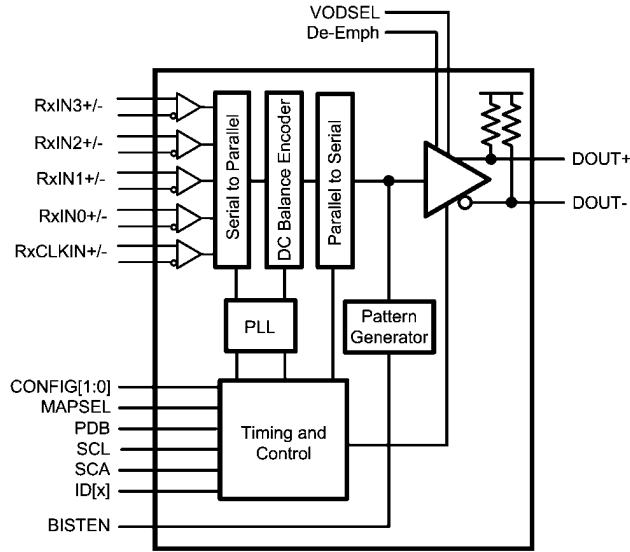

DS92LV0411

30125228

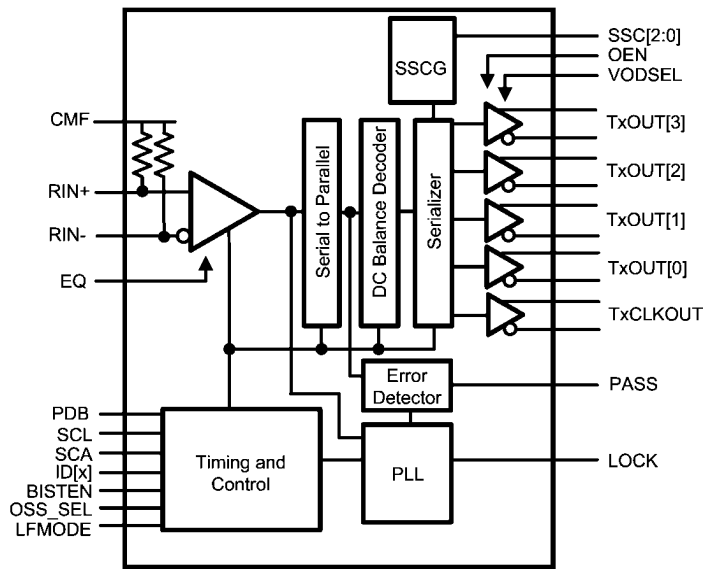

DS92LV0412

30125272

Ordering Information

NSID	Package Description	Quantity	SPEC	Package ID
DS92LV0411SQE	36-pin LLP, 6.0 X 6.0 X 0.8 mm, 0.5 mm pitch	250	NOPB	SQA36A
DS92LV0411SQ	36-pin LLP, 6.0 X 6.0 X 0.8 mm, 0.5 mm pitch	1000	NOPB	SQA36A
DS92LV0411SQX	36-pin LLP, 6.0 X 6.0 X 0.8 mm, 0.5 mm pitch	2500	NOPB	SQA36A
DS92LV0412SQE	48-pin LLP, 7.0 X 7.0 X 0.8 mm, 0.5 mm pitch	250	NOPB	SQA48A
DS92LV0412SQ	48-pin LLP, 7.0 X 7.0 X 0.8 mm, 0.5 mm pitch	1000	NOPB	SQA48A
DS92LV0412SQX	48-pin LLP, 7.0 X 7.0 X 0.8 mm, 0.5 mm pitch	2500	NOPB	SQA48A

DS92LV0411 Pin Diagram

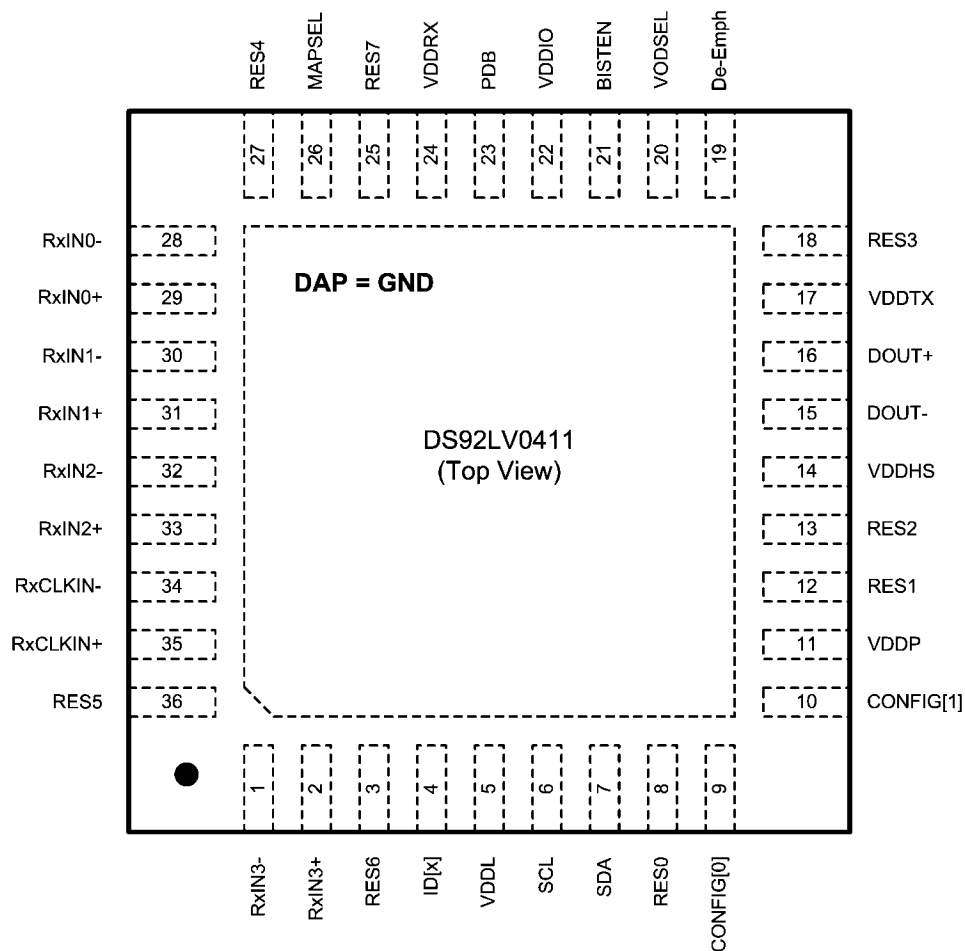

DS92LV0411 — Top View

30125219

DS92LV0411 Pin Descriptions

Pin Name	Pin #	I/O, Type	Description
Channel Link Parallel Input Interface			
RxIN[3:0]+	2, 33, 31, 29	I, LVDS	True LVDS Data Input This pair should have a 100 Ω termination for standard LVDS levels.
RxIN[3:0]-	1, 34, 32, 30, 28	I, LVDS	Inverting LVDS Data Input This pair should have a 100 Ω termination for standard LVDS levels.
RxCLKIN+	35	I, LVDS	True LVDS Clock Input This pair should have a 100 Ω termination for standard LVDS levels.
RxCLKIN-	34	I, LVDS	Inverting LVDS Clock Input This pair should have a 100 Ω termination for standard LVDS levels.
Control and Configuration			
PDB	23	I, LVCMOS w/ pull-down	Power-down Mode Input PDB = 1, Device is enabled (normal operation). Refer to "Power Up Requirements and PDB Pin" in the Applications Information Section. PDB = 0, Device is powered down When the Device is in the power-down state, the driver outputs (DOUT+/-) are both logic high, the PLL is shutdown, IDD is minimized. Control Registers are RESET .

Pin Name	Pin #	I/O, Type	Description
VODSEL	20	I, LVCMOS w/ pull-down	Differential Driver Output Voltage Select — Pin or Register Control VODSEL = 1, LVDS VOD is ± 450 mV, 900 mVp-p (typ) — Long Cable / De-E Applications VODSEL = 0, LVDS VOD is ± 300 mV, 600 mVp-p (typ)
De-Emph	19	I, Analog w/ pull-up	De-Emphasis Control — Pin or Register Control De-Emph = open (float) - disabled To enable De-emphasis, tie a resistor from this pin to GND or control via register. See Table 4
MAPSEL	26	I, LVCMOS w/ pull-down	Channel Link Map Select — Pin or Register Control MAPSEL = 1, MSB on RxIN3+/- . Figure 22 MAPSEL = 0, LSB on RxIN3+/- . Figure 21
CONFIG [1:0]	10, 9	I, LVCMOS w/ pull-down	Operating Modes — Pin or Limited Register Control Determines the device operating mode and interfacing device. Table 1 CONFIG[1:0] = 00: Interfacing to DS92LV2412 or DS92LV0412, Control Signal Filter DISABLED CONFIG[1:0] = 01: Interfacing to DS92LV2412 or DS92LV0412, Control Signal Filter ENABLED CONFIG [1:0] = 10: Interfacing to DS90UR124, DS99R124 CONFIG [1:0] = 11: Interfacing to DS90C124
ID[x]	4	I, Analog	Serial Control Bus Device ID Address Select — Optional Resistor to Ground and 10 k Ω pull-up to 1.8V rail. See Table 10 .
SCL	6	I, LVCMOS	Serial Control Bus Clock Input - Optional SCL requires an external pull-up resistor to V_{DDIO} .
SDA	7	I/O, LVCMOS Open Drain	Serial Control Bus Data Input / Output - Optional SDA requires an external pull-up resistor V_{DDIO} .
BISTEN	21	I, LVCMOS w/ pull-down	BIST Mode — Optional BISTEN = 1, BIST is enabled BISTEN = 0, BIST is disabled
RES[7:0]	25, 3, 36, 27, 18, 13, 12, 8	I, LVCMOS w/ pull-down	Reserved - tie LOW
Channel Link II Serial Interface			
DOUT+	16	O, CML	True Output. The output must be AC Coupled with a 0.1 μ F capacitor.
DOUT-	15	O, CML	Inverting Output. The output must be AC Coupled with a 0.1 μ F capacitor.
Power and Ground			
VDDL	5	Power	Logic Power, 1.8 V $\pm 5\%$
VDDP	11	Power	PLL Power, 1.8 V $\pm 5\%$
VDDHS	14	Power	TX High Speed Logic Power, 1.8 V $\pm 5\%$
VDDTX	17	Power	Output Driver Power, 1.8 V $\pm 5\%$
VDDRX	24	Power	RX Power, 1.8 V $\pm 5\%$
VDDIO	22	Power	LVCMOS I/O Power and Channel Link I/O Power 1.8 V $\pm 5\%$ OR 3.3 V $\pm 10\%$
GND	DAP	Ground	DAP is the large metal contact at the bottom side, located at the center of the LLP package. Connect to the ground plane (GND) with at least 9 vias.

NOTE: 1= HIGH, 0 L= LOW

The VDD (V_{DDn} and V_{DDIO}) supply ramp should be faster than 1.5 ms with a monotonic rise. If slower than 1.5 ms then a capacitor on the PDB pin is needed to ensure PDB arrives after all the VDD have settled to the recommended operating voltage.

DS92LV0412 Pin Diagram

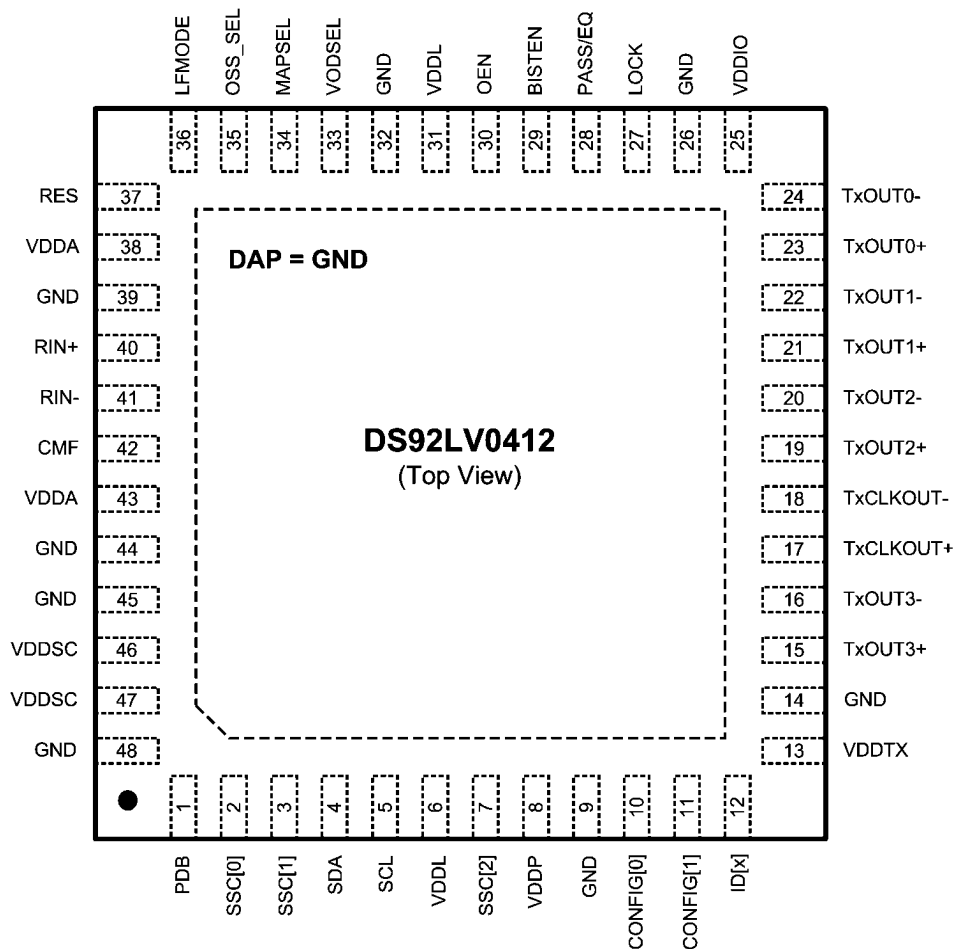

DS92LV0412 — Top View

30125271

DS92LV0412 Pin Descriptions

Pin Name	Pin #	I/O, Type	Description
Channel Link II Serial Interface			
RIN+	40	I, CML	True Input. The output must be AC Coupled with a 0.1 μ F capacitor.
RIN-	41	I, CML	Inverting Input. The output must be AC Coupled with a 0.1 μ F capacitor.
Channel Link Parallel Output Interface			
RxIN[3:0]+	15, 19, 21, 23	O, LVDS	True LVDS Data Output This pair should have a 100 Ω termination for standard LVDS levels.
RxIN[3:0]-	16, 20, 22, 24	O, LVDS	Inverting LVDS Data Output This pair should have a 100 Ω termination for standard LVDS levels.
RxCLKIN+	17	O, LVDS	True LVDS Clock Output This pair should have a 100 Ω termination for standard LVDS levels.
RxCLKIN-	18	O, LVDS	Inverting LVDS Clock Output This pair should have a 100 Ω termination for standard LVDS levels.

Pin Name	Pin #	I/O, Type	Description
LVC MOS Outputs			
LOCK	27	O, LVC MOS	LOCK Status Output LOCK = 1, PLL is locked, output stated determined by OEN. LOCK = 0, PLL is unlocked, output states determined by OSS_SEL and OEN. See Table XXX.
Control and Configuration			
PDB	1	I, LVC MOS w/ pull-down	Power-down Mode Input PDB = 1, Device is enabled (normal operation). Refer to "Power Up Requirements and PDB Pin" in the Applications Information Section. PDB = 0, Device is powered down When the Device is in the power-down state, the driver outputs (DOOUT+/-) are both logic high, the PLL is shutdown, IDD is minimized. Control Registers are RESET .
VODSEL	33	I, LVC MOS w/ pull-down	Parallel LVDS Driver Output Voltage Select — Pin or Register Control VODSEL = 1, LVDS VOD is ± 450 mV, 900 mVp-p (typ) — Long Cable / De-E Applications VODSEL = 0, LVDS VOD is ± 300 mV, 600 mVp-p (typ)
OEN	30	I, LVC MOS w/ pull-down	Output Enable. See Table 5 .
OSS_SEL	35	I, LVC MOS w/ pull-down	Output Sleep State Select Input. See Table 5 .
LFMODE	36	I, LVC MOS w/ pull-down	SSCG Low Frequency Mode — Pin or Register Control LF_MODE = 1, low frequency mode (TxCLKOUT = 10–20 MHz) LF_MODE = 0, high frequency mode (TxCLKOUT = 20–65 MHz) SSCG not available above 65 MHz.
MAPSEL	34	I, LVC MOS w/ pull-down	Channel Link Map Select — Pin or Register Control MAPSEL = 1, MSB on TxOUT3+/-. MAPSEL = 0, LSB on TxOUT3+/-.
CONFIG [1:0]	11, 10	I, LVC MOS w/ pull-down	Operating Modes — Pin or Limited Register Control Determine the device operating mode and interfacing device. CONFIG[1:0] = 00: Interfacing to DS92LV2411 or DS92LV0411, Control Signal Filter DISABLED CONFIG[1:0] = 01: Interfacing to DS92LV2411 or DS92LV0411, Control Signal Filter ENABLED CONFIG [1:0] = 10: Interfacing to DS90UR241, DS99R421 CONFIG [1:0] = 11: Interfacing to DS90C124
SSC[2:0]	7, 2, 3	I, LVC MOS w/ pull-down	Spread Spectrum Clock Generation (SSCG) Range Select See Table 8 , Table 9
RES	37	I, LVC MOS w/ pull-down	Reserved
Control and Configuration — STRAP PIN			
EQ	28 [PASS]	STRAP I, LVC MOS w/ pull-down	EQ Gain Control of Channel Link II Serial Input EQ = 1, EQ gain is enabled (~12 dB) EQ = 0, EQ gain is disabled (~ 1.625 dB)
Optional BIST Mode			
BISTEN	29	I, LVC MOS w/ pull-down	BIST Mode — Optional BISTEN = 1, BIST is enabled BISTEN = 0, BIST is disabled
PASS	28	O, LVC MOS	PASS Output (BIST Mode) — Optional PASS = 1, no errors detected PASS = 0, errors detected Leave open if unused. Route to a test point (pad) recommended.

Pin Name	Pin #	I/O, Type	Description
Optional Serial Bus Control			
ID[x]	12	I, Analog	Serial Control Bus Device ID Address Select — Optional Resistor to Ground and 10 kΩ pull-up to 1.8V rail. See .
SCL	5	I, LVCMOS Open Drain	Serial Control Bus Clock Input - Optional SCL requires an external pull-up resistor to 3.3V.
SDA	4	I/O, LVCMOS Open Drain	Serial Control Bus Data Input / Output - Optional SDA requires an external pull-up resistor 3.3V.
Power and Ground			
VDDL	6, 31	Power	Logic Power, 1.8 V ±5%
VDDA	38, 43	Power	Analog Power, 1.8 V ±5%
VDDP	6	Power	PLL Power, 1.8 V ±5%
VDDSC	46, 47	Power	SSC Generator Power, 1.8 V ±5%
VDDTX	24	Power	Channel Link LVDS Parallel Output Power, 1.8 V ±5%
VDDIO	25	Power	LVCMOS I/O Power and Channel Link I/O Power 1.8 V ±5% OR 3.3 V ±10%
GND	9, 14, 26, 32, 39, 44, 45, 48	Ground	Ground
DAP	DAP	Ground	DAP is the large metal contact at the bottom side, located at the center of the LLP package. Connect to the ground plane (GND) with at least 9 vias.

NOTE: 1= HIGH, 0 L= LOW

The VDD (V_{DDn} and V_{DDIO}) supply ramp should be faster than 1.5 ms with a monotonic rise. If slower than 1.5 ms then a capacitor on the PDB pin is needed to ensure PDB arrives after all the VDD have settled to the recommended operating voltage.

Absolute Maximum Ratings *(Note 1)*

If Military/Aerospace specified devices are required, please contact the National Semiconductor Sales Office/Distributors for availability and specifications.

Supply Voltage – V_{DDn} (1.8V)	–0.3V to +2.5V
Supply Voltage – V_{DDIO}	–0.3V to +4.0V
Supply Voltage – V_{DDTX} (3.3V)	–0.3V to +4.0V
LVC MOS I/O Voltage	–0.3V to $(V_{DDIO} + 0.3V)$
LVDS Input Voltage	–0.3V to $(V_{DDIO} + 0.3V)$
LVDS Output Voltage	–0.3V to $(V_{DDTX} + 0.3V)$
CML Driver Output Voltage	–0.3V to $(-V_{DDn} + 0.3V)$
Receiver Input Voltage	–0.3V to $(V_{DD} + 0.3V)$
Junction Temperature	+150°C
Storage Temperature	–65°C to +150°C
36L LLP Package	
Maximum Power Dissipation	
Capacity at 25°C	
Derate above 25°C	$1/\theta_{JA}$ °C/W
θ_{JA}	27.4 °C/W
θ_{JC}	4.5 °C/W
48L LLP Package	
Maximum Power Dissipation	
Capacity at 25°C	
Derate above 25°C	$1/\theta_{JA}$ °C/W
θ_{JA}	27.7 °C/W
θ_{JC}	3.0 °C/W

ESD Rating (IEC, powered-up only), $R_D = 330\Omega$, $C_S = 150$ pF

Air Discharge (R_{IN+} , R_{IN-})	$\geq \pm 30$ kV
Contact Discharge (R_{IN+} , R_{IN-})	$\geq \pm 8$ kV
ESD Rating (HBM)	$\geq \pm 8$ kV
ESD Rating (CDM)	$\geq \pm 1.25$ kV
ESD Rating (MM)	$\geq \pm 250$ V

For soldering specifications:

See product folder at www.national.com and www.national.com/ms/MS/MS-SOLDERING.pdf

Recommended Operating Conditions

	Min	Nom	Max	Units
Supply Voltage (V_{DDn})	1.71	1.8	1.89	V
Supply Voltage (V_{DDTX})	3.0	3.3	3.6	V
LVC MOS Supply Voltage (V_{DDIO})	1.71	1.8	1.89	V
OR				
LVC MOS Supply Voltage (V_{DDIO})	3.0	3.3	3.6	V
Operating Free Air Temperature (T_A)	–40	+25	+85	°C
RxCLKIN/TxCLKOUT Clock Frequency	5		50	MHz
Supply Noise (<i>Note 10</i>)			100	mV _{P-P}

DC Electrical Characteristics

Over recommended operating supply and temperature ranges unless otherwise specified. (*Note 2, Note 3, Note 4*)

Symbol	Parameter	Conditions	Pin/Freq.	Min	Typ	Max	Units	
DS92LV0411 LVC MOS INPUT DC SPECIFICATIONS								
V_{IH}	High Level Input Voltage	$V_{DDIO} = 3.0$ to $3.6V$	PDB, VODSEL, MAPSEL, CONFIG[1:0], BISTEN	2.0		V_{DDIO}	V	
		$V_{DDIO} = 1.71$ to $1.89V$		0.65^*		V_{DDIO}	V	
V_{IL}	Low Level Input Voltage	$V_{DDIO} = 3.0$ to $3.6V$		GND			0.8	V
		$V_{DDIO} = 1.71$ to $1.89V$		GND			0.35^* V_{DDIO}	V
I_{IN}	Input Current	$V_{IN} = 0V$ or V_{DDIO}	$V_{DDIO} = 3.0$ to $3.6V$	–15	± 1	+15	μA	
			$V_{DDIO} = 1.7$ to $1.89V$	–15	± 1	+15	μA	

Symbol	Parameter	Conditions	Pin/Freq.	Min	Typ	Max	Units	
DS92LV0412 LVCMOS I/O DC SPECIFICATIONS								
V _{IH}	High Level Input Voltage	V _{DDIO} = 3.0 to 3.6V	PDB, VODSEL, OEN, MAPSEL, LFMODE, SSC[2:0], BISTEN	2.0		V _{DDIO}	V	
		V _{DDIO} = 1.71 to 1.89V		0.65* V _{DDIO}		V _{DDIO}	V	
V _{IL}	Low Level Input Voltage	V _{DDIO} = 3.0 to 3.6V		GND		0.8	V	
		V _{DDIO} = 1.71 to 1.89V		GND		0.35* V _{DDIO}	V	
I _{IN}	Input Current	V _{IN} = 0V or V _{DDIO}		V _{DDIO} = 3.0 to 3.6V	-15	±1	+15	µA
				V _{DDIO} = 1.7 to 1.89V	-15	±1	+15	µA
V _{OH}	High Level Output Voltage	I _{OH} = -0.5 mA	LOCK, PASS	V _{DDIO} - 0.2	V _{DDIO}		V	
V _{OL}	Low Level Output Voltage	I _{OL} = +0.5 mA			GND	0.2	V	
I _{OS}	Output Short Circuit Current	V _{OUT} = 0V		V _{DDIO} = 3.0 to 3.6 V		-10		mA
				V _{DDIO} = 1.71 to 1.89V		-3		
I _{OZ}	TRI-STATE® Output Current	PDB = 0V, OSS_SEL = 0V, V _{OUT} = 0V or V _{DDIO}		V _{DDIO} = 3.0 to 3.6 V	-10		+10	µA
				V _{DDIO} = 1.71 to 1.89V	-15		+15	
DS92LV0411 CHANNEL LINK PARALLEL LVDS RECEIVER DC SPECIFICATIONS								
V _{TH}	Differential Threshold High Voltage	V _{CM} = 1.2V, <i>Figure 1</i>	RxIN[3:0]+/-, RxCLKIN+/-,			+100	mV	
V _{TL}	Differential Threshold Low Voltage			-100				
V _{ID}	Differential Input Voltage Swing			200		600	mV	
V _{CM}	Common Mode Voltage			V _{DDIO} = 3.3V	0	1.2	2.4	V
		V _{DDIO} = 1.8V		0	1.2	1.7		
I _{IN}	Input Current			-10	±1	+10	µA	
DS92LV0412 CHANNEL LINK PARALLEL LVDS DRIVER DC SPECIFICATIONS								
V _{OD}	Differential Output Voltage	R _L = 100Ω	RxCLKOUT +, TxCLKOUT-, TxOUT[3:0]+, TxOUT[3:0]-	VODSEL = L	100	250	400	mV
				VODSEL = H	200	400	600	mV
V _{ODP-P}	Differential Output Voltage A – B			VODSEL = L		500		mVp-p
				VODSEL = H		800		mVp-p
ΔV _{OD}	Output Voltage Unbalance					1	50	mV
V _{OS}	Offset Voltage			VODSEL = L	1.0	1.2	1.5	V
				VODSEL = H		1.2		V
ΔV _{OS}	Offset Voltage Unbalance					1	50	mV
I _{OS}	Output Short Circuit Current					-5		mA
I _{OZ}	Output TRI-STATE® Current				-10		+10	µA

Symbol	Parameter	Conditions	Pin/Freq.	Min	Typ	Max	Units		
DS92LV0411 Channel Link II CML DRIVER DC SPECIFICATIONS									
V _{OD}	Differential Output Voltage	R _L = 100Ω, De-emph = disabled, <i>Figure 3</i>	VODSEL = 0	DOUT+, DOUT-	±225	±300	±375	mV	
			VODSEL = 1		±350	±450	±550		
V _{ODp-p}	Differential Output Voltage (DOUT+) – (DOUT-)		VODSEL = 0			600		mVp-p	
			VODSEL = 1			900		mVp-p	
ΔV _{OD}	Output Voltage Unbalance	R _L = 100Ω, De-emph = disabled, VODSEL = L			1	TBD	mV		
V _{OS}	Offset Voltage – Single-ended At TP A & B, <i>Figure 2</i>	R _L = 100Ω, De-emph = disabled	VODSEL = 0		1.65		V		
			VODSEL = 1		1.575		V		
ΔV _{OS}	Offset Voltage Unbalance Single-ended At TP A & B, <i>Figure 2</i>	R _L = 100Ω, De-emph = disabled			1		mV		
I _{OS}	Output Short Circuit Current	DOUT+/- = 0V, De-emph = disabled	VODSEL = 0		-36		mA		
R _T	Internal Termination Resistor			80		120	Ω		
DS92LV0412 CHANNEL LINK II CML RECEIVER DC SPECIFICATIONS									
V _{TH}	Differential Input Threshold High Voltage	V _{CM} = +1.2V (Internal V _{BIAS})		RIN+, RIN-			+50	mV	
V _{TL}	Differential Input Threshold Low Voltage						-50		
V _{CM}	Common mode Voltage, Internal V _{BIAS}				1.2		V		
R _T	Input Termination				85	100	115	Ω	
DS92LV0411 SUPPLY CURRENT									
I _{DDT1}	Supply Current (includes load current) R _L = 100Ω, f = 50 MHz	Checker Board Pattern, De-emph = disabled, VODSEL = H, <i>Figure 16</i>	V _{DD} = 1.89V	All V _{DD} pins		65	TBD	mA	
I _{DDIOT1}			V _{DDIO} = 1.89V		V _{DDIO}		TBD	TBD	mA
		V _{DDIO} = 3.6V			TBD	TBD	mA		
I _{DDT2}		Checker Board Pattern, De-emph = disabled, VODSEL = L, <i>Figure 16</i>	V _{DD} = 1.89V	All V _{DD} pins		TBD	TBD	mA	
I _{DDIOT2}			V _{DDIO} = 1.89V		V _{DDIO}		TBD	TBD	mA
		V _{DDIO} = 3.6V			TBD	TBD	mA		
I _{DDT3}	RANDOM pattern, De-emph = disabled, VODSEL = H	V _{DD} = 1.89V	All V _{DD} pins		TBD		mA		
I _{DDIOT3}		V _{DDIO} = 1.89V		V _{DDIO}		TBD		mA	
	V _{DDIO} = 3.6V			TBD		mA			
I _{DDZ}	Supply Current Power-down	PDB = 0V, (All other LVCMOS Inputs = 0V)	V _{DD} = 1.89V	All V _{DD} pins		100	TBD	μA	
I _{DDIOZ}			V _{DDIO} = 1.89V		V _{DDIO}		TBD	TBD	μA
			V _{DDIO} = 3.6V				TBD	TBD	μA
DS92LV0412 SUPPLY CURRENT									
I _{DD1}	Supply Current (Includes load current)	Checker Board Pattern, VODSEL = H, SSCG = On	V _{DDn} = 1.89 V	All V _{DD(1:8)} pins		TBD	TBD	mA	
I _{DDTX1}	50 MHz Clock		V _{DDTX} = 3.6 V		V _{DDTX}		TBD	TBD	mA
I _{DDIO1}			V _{DDIO} = 1.89 V		V _{DDIO}		TBD	TBD	mA
			V _{DDIO} = 3.6 V				TBD	TBD	mA

Symbol	Parameter	Conditions	Pin/Freq.	Min	Typ	Max	Units	
I_{DDZ}	Supply Current Power Down	PDB = 0V, All other LVCMOS Inputs = 0V	$V_{DD} = 1.89\text{ V}$	All $V_{DD(1:8)}$ pins		TBD	TBD	mA
I_{DDTXZ}			$V_{DDTX} = 3.6\text{ V}$	V_{DDTX}		TBD	TBD	mA
I_{DDIOZ}			$V_{DDIO} = 1.89\text{ V}$	V_{DDIO}		TBD	TBD	mA
			$V_{DDIO} = 3.6\text{ V}$			TBD	TBD	mA

Switching Characteristics

Over recommended operating supply and temperature ranges unless otherwise specified.

Symbol	Parameter	Conditions	Min	Typ	Max	Units	
DS92LV0411 CHANNEL LINK PARALLEL LVDS INPUT							
t_{RSP0}	Receiver Strobe Position-bit 0	RxCLKIN = 50 MHz, RxIN[3:0] <i>Figure 5</i>		TBD	1.1	TBD	ns
t_{RSP1}	Receiver Strobe Position-bit 1			TBD	3.3	TBD	ns
t_{RSP2}	Receiver Strobe Position-bit 2			TBD	5.5	TBD	ns
t_{RSP3}	Receiver Strobe Position-bit 3			TBD	7.7	TBD	ns
t_{RSP4}	Receiver Strobe Position-bit 4			TBD	9.9	TBD	ns
t_{RSP5}	Receiver Strobe Position-bit 5			TBD	12.1	TBD	ns
t_{RSP6}	Receiver Strobe Position-bit 6			TBD	14.3	TBD	ns
R_{JIT}	RxCLKIN Cycle-to-Cycle Jitter (Input clock requirement)					TBD	ns
DS92LV0412 CHANNEL LINK PARALLEL LVDS OUTPUT							
t_{LHT}	Low to High Transition Time	$R_L = 100\Omega$		0.3	0.6	ns	
t_{THLT}	High to Low Transition Time			0.3	0.6	ns	
t_{DCCJ}	Cycle-to-Cycle Output Jitter	$TxCLKOUT_{\pm} = 5\text{ MHz}$		900	2100	ps	
		$TxCLKOUT_{\pm} = 50\text{ MHz}$		75	125	ps	
t_{TTP1}	Transmitter Pulse Position for bit 1	5 – 50 MHz		0		UI	
t_{TTP0}	Transmitter Pulse Position for bit 0			1		UI	
t_{TTP6}	Transmitter Pulse Position for bit 6			2		UI	
t_{TTP5}	Transmitter Pulse Position for bit 5			3		UI	
t_{TTP4}	Transmitter Pulse Position for bit 4			4		UI	
t_{TTP3}	Transmitter Pulse Position for bit 3			5		UI	
t_{TTP2}	Transmitter Pulse Position for bit 2			6		UI	
t_{SD}	Delay-Latency				TBD	TBD	ns
t_{TPDD}	Power Down Delay Active to OFF	50 MHz		6	10	ns	
t_{TXZR}	Enable Delay OFF to Active	50 MHz		40	55	ns	
DS92LV0411 Channel Link II CML OUTPUT							
t_{HLT}	Output Low-to-High Transition Time <i>Figure 3</i>	$R_L = 100\Omega$, De-emphasis = disabled, VODSEL = 0	100	200	300	ps	
		$R_L = 100\Omega$, De-emphasis = disabled, VODSEL = 1	100	200	300	ps	

Symbol	Parameter	Conditions	Min	Typ	Max	Units
t _{HLT}	Output High-to-Low Transition Time <i>Figure 4</i>	R _L = 100Ω, De-emphasis = disabled, VODSEL = 0	130	260	390	ps
		R _L = 100Ω, De-emphasis = disabled, VODSEL = 1	100	200	300	ps
t _{XZD}	Output Active to OFF Delay, <i>Figure 9</i>			TBD	TBD	ns
t _{PLD}	PLL Lock Time, <i>Figure 7</i>	R _L = 100Ω			10	ms
t _{SD}	Delay - Latency, <i>Figure 10</i>	R _L = 100Ω		140*T	TBD	ns
t _{DJIT}	Output Total Jitter, <i>Figure 12</i>	R _L = 100Ω, De-Emph = disabled, RANDOM pattern		0.3	TBD	UI
λ _{STXBW}	Jitter Transfer Function -3 dB Bandwidth			TBD		kHz
δ _{STX}	Jitter Transfer Function Peaking			TBD		dB
DS92LV0412 CHANNEL LINK II CML INPUT						
t _{DDL}	Lock Time	SSCG = OFF, 5 MHz		TBD		ms
		SSCG = ON, 5 MHz		TBD		ms
		SSCG = OFF, 50 MHz		TBD		ms
		SSCG = ON, 50 MHz		TBD		ms
t _{DJIT}	Input Jitter Tolerance	EQ = OFF Jitter Frequency > 10 MHz		>0.45		UI
DS92LV0412 LVC MOS OUTPUTS						
t _{CLH}	Low to High Transition Time	C _L = 8 pF		10	15	ns
t _{CHL}	High to Low Transition Time	LOCK pin, PASS pin		10	15	ns
t _{PASS}	BIST PASS Valid Time, BISTEN = 1	PASS pin 5 MHz		560	570	ns
		50 MHz		70	75	ns
DS92LV0412 SSCG MODE						
t _{DEV}	Spread Spectrum Clocking Deviation Frequency	TxCLKOUT = 5 – 50 MHz, SSC[2:0] = ON	±0.5		±2	%
t _{MOD}	Spread Spectrum Clocking Modulation Frequency	TxCLKOUT = 5 – 50 MHz, SSC[2:0] = ON	8		100	kHz

DC and AC Serial Control Bus Characteristics

Over recommended operating supply and temperature ranges unless otherwise specified.

Symbol	Parameter	Conditions	Min	Typ	Max	Units
V_{IH}	Input High Level	SDA and SCL	0.7* V_{DDIO}		V_{DDIO}	V
V_{IL}	Input Low Level Voltage	SDA and SCL	GND		0.3* V_{DDIO}	V
V_{HY}	Input Hysteresis			>50		mV
V_{OL}		SDA, IOL = 3mA	0		0.36	V
I_{in}		SDA or SCL, $V_{in} = V_{DDIO}$ or GND	-10		+10	μ A
t_R	SDA RiseTime – READ	SDA, RPU = X, $C_b \leq 400$ pF, Figure 18	TBD		TBD	ns
t_F	SDA Fall Time – READ		TBD		TBD	ns
$t_{SU,DAT}$	Set Up Time — READ	Figure 18	TBD			ns
$t_{HD,DAT}$	Hold Up Time — READ	Figure 18	TBD			ns
t_{SP}	Input Filter			50		ns
C_{in}	Input Capacitance	SDA or SCL		<5		pF

Note 1: “Absolute Maximum Ratings” indicate limits beyond which damage to the device may occur, including inoperability and degradation of device reliability and/or performance. Functional operation of the device and/or non-degradation at the Absolute Maximum Ratings or other conditions beyond those indicated in the Recommended Operating Conditions is not implied. The Recommended Operating Conditions indicate conditions at which the device is functional and the device should not be operated beyond such conditions.

Note 2: The Electrical Characteristics tables list guaranteed specifications under the listed Recommended Operating Conditions except as otherwise modified or specified by the Electrical Characteristics Conditions and/or Notes. Typical specifications are estimations only and are not guaranteed.

Note 3: Typical values represent most likely parametric norms at $V_{DD} = 3.3$ V, $T_a = +25$ degC, and at the Recommended Operation Conditions at the time of product characterization and are not guaranteed.

Note 4: Current into device pins is defined as positive. Current out of a device pin is defined as negative. Voltages are referenced to ground except VOD, Δ VOD, VTH and VTL which are differential voltages.

Note 5: When the device output is at TRI-STATE the Deserializer will lose PLL lock. Resynchronization / Relock must occur before data transfer require t_{PLD}

Note 6: t_{PLD} is the time required by the device to obtain lock when exiting power-down state with an active RxCLKIN.

Note 7: UI – Unit Interval is equivalent to one serialized data bit width ($1UI = 1 / 28 * PCLK$). The UI scales with PCLK frequency.

Note 8: t_{DPJ} is the maximum amount the period is allowed to deviate over many samples.

Note 9: t_{DCCJ} is the maximum amount of jitter between adjacent clock cycles.

Note 10: Supply noise testing was done with minimum capacitors on the PCB. A sinusoidal signal is AC coupled to the V_{DDn} (1.8V) supply with amplitude = 100 mVp-p measured at the device V_{DDn} pins. Bit error rate testing of input to the Ser and output of the Des with 10 meter cable shows no error when the noise frequency on the Ser is less than 750 kHz. The Des on the other hand shows no error when the noise frequency is less than 400 kHz.

Note 11: Specification is guaranteed by characterization and is not tested in production.

Note 12: Specification is guaranteed by design and is not tested in production.

AC Timing Diagrams and Test Circuits

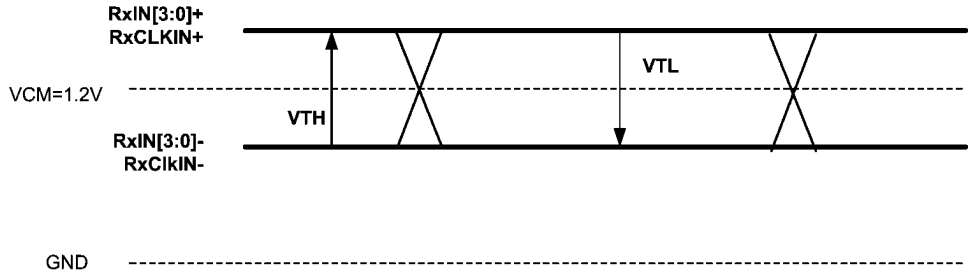

30125262

FIGURE 1. Channel Link DC VTH/VTL Definition

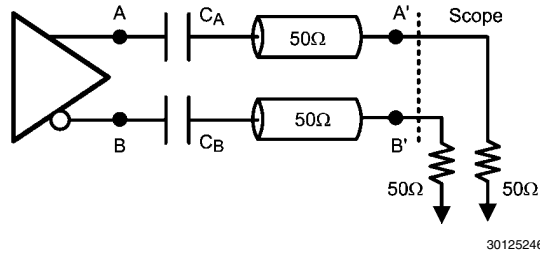

30125246

FIGURE 2. Output Test Circuit

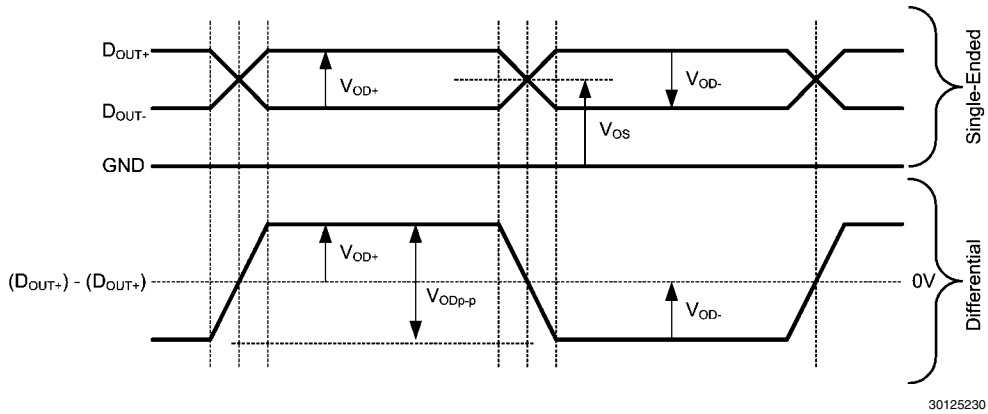

30125230

FIGURE 3. Output Waveforms

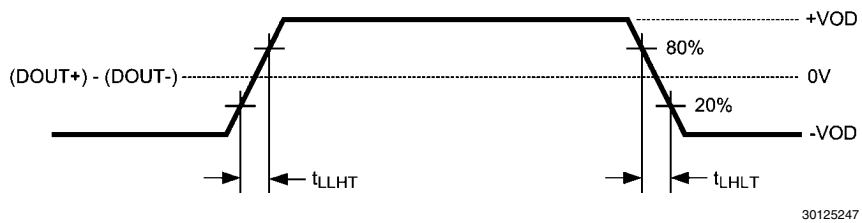

30125247

FIGURE 4. Output Transition Times

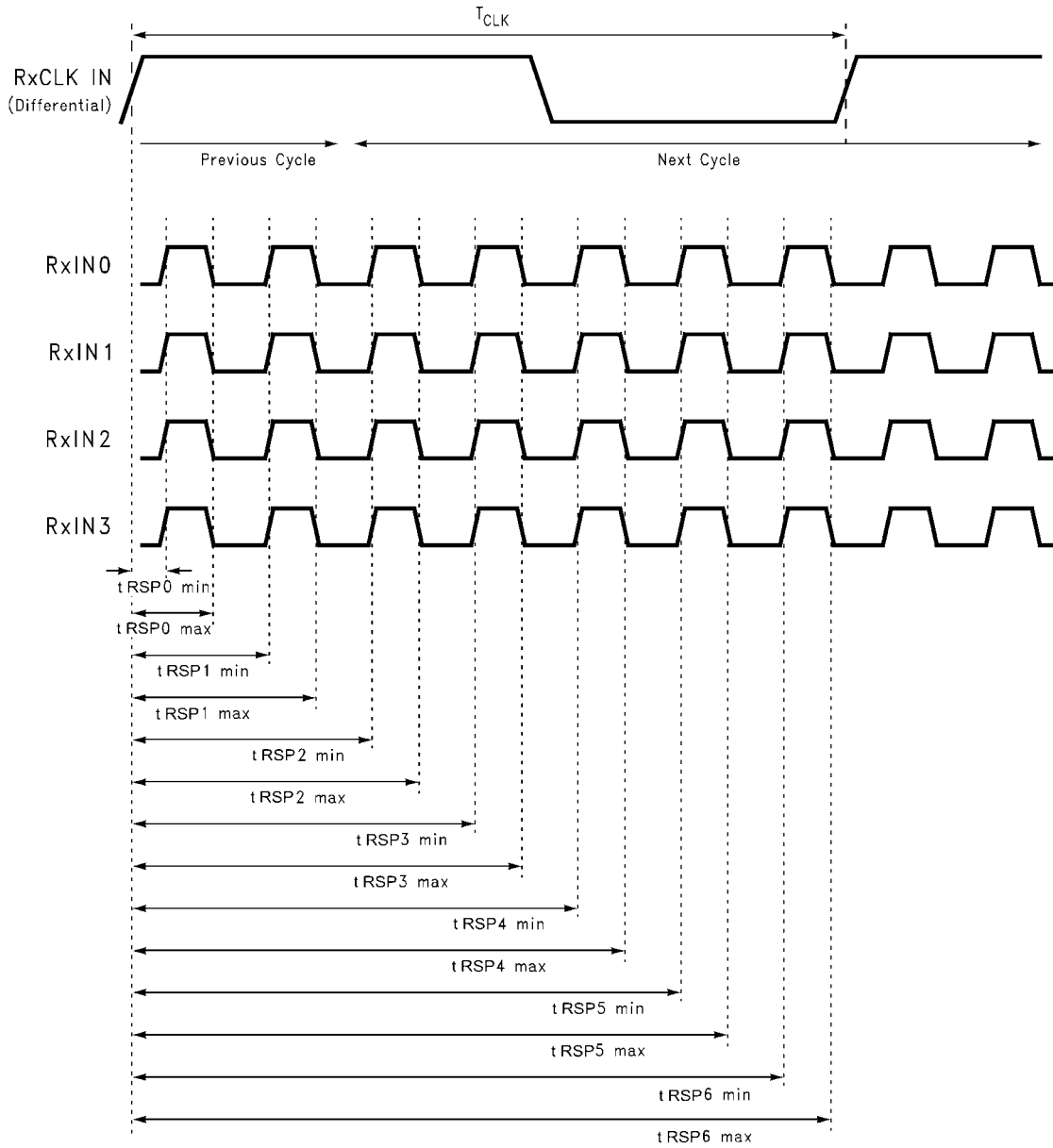

30125261

FIGURE 5. DS92LV0411 LVDS Receiver Strobe Positions

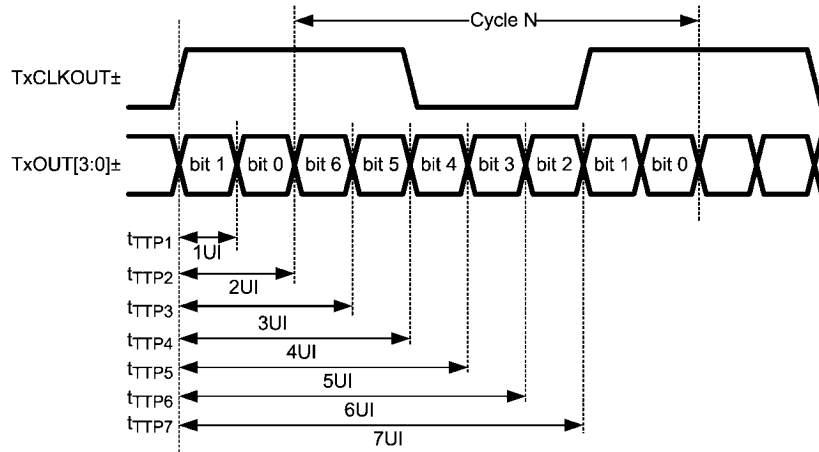

30125270

FIGURE 6. DS92LV0412 LVDS Transmitter Pulse Positions

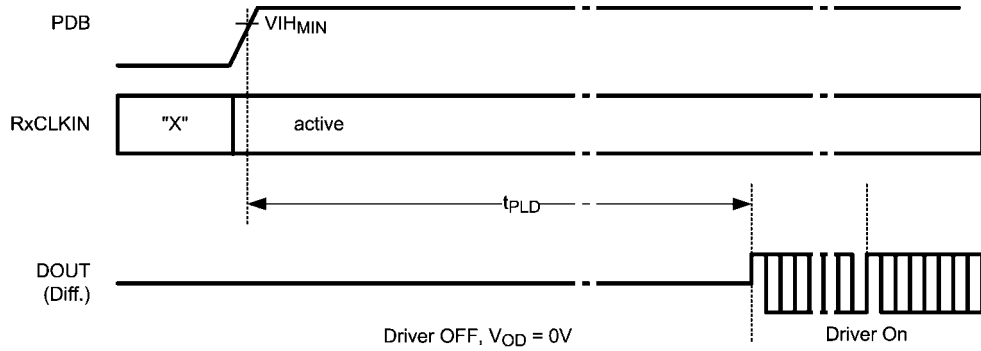

30125248

FIGURE 7. DS92LV0411 Lock Time

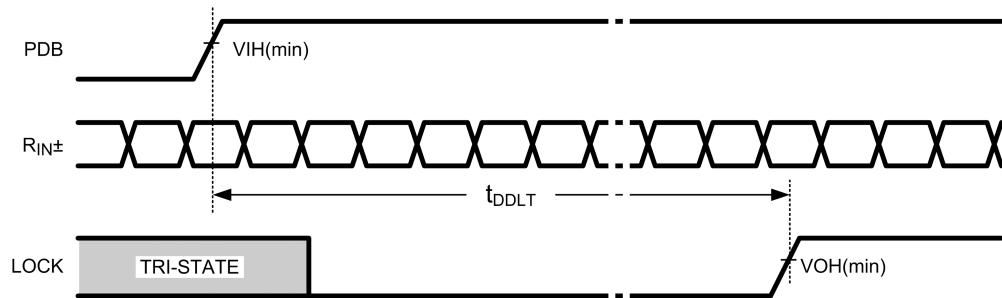

30125268

FIGURE 8. DS92LV0412 Lock Time

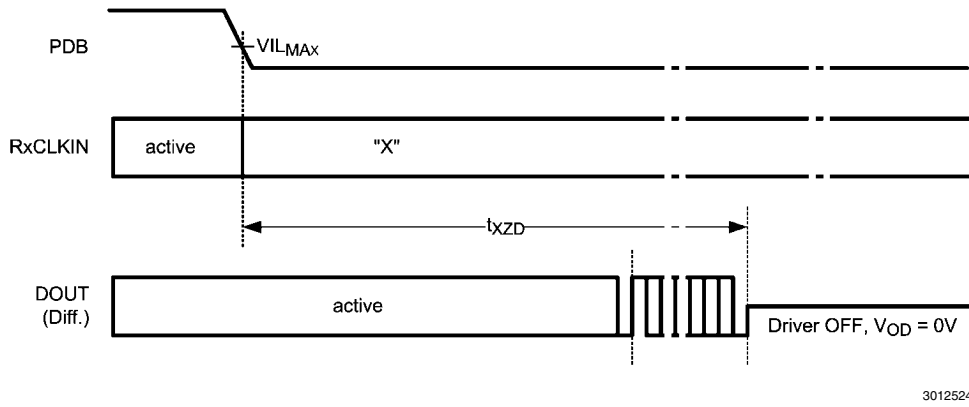

30125249

FIGURE 9. DS92LV0411 Disable Time

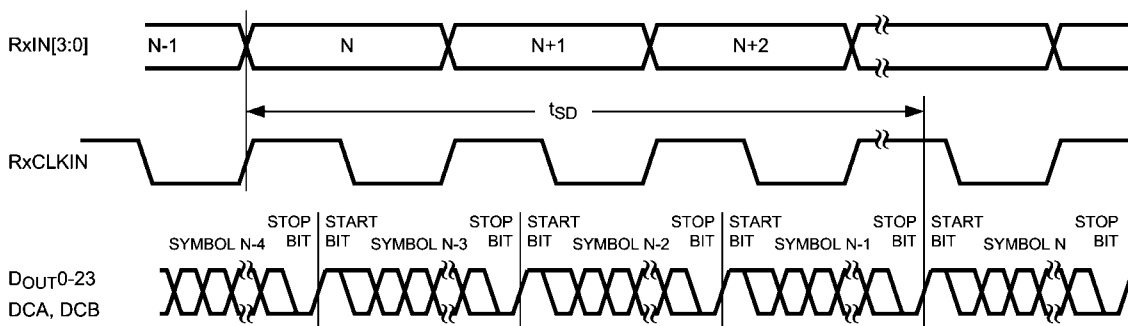

30125210

FIGURE 10. DS92LV0411 Latency Delay

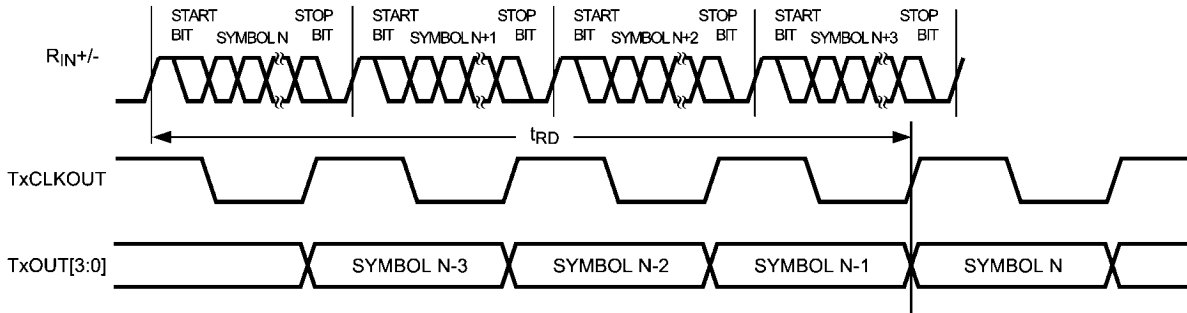

30125267

FIGURE 11. DS92LV0412 Latency Delay

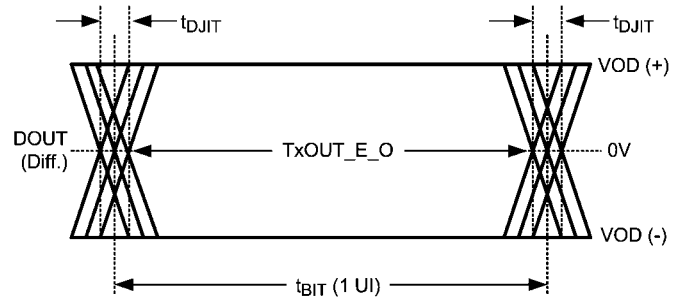

30125250

FIGURE 12. Output Jitter

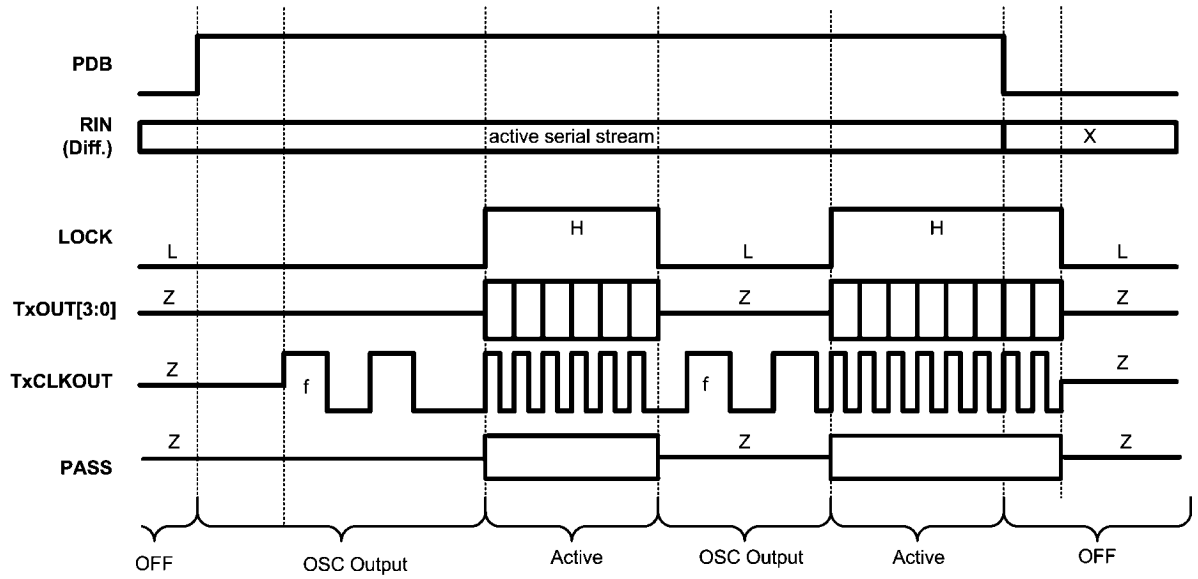

CONDITIONS: OEN = H, OSS_SEL = H, and OSC_SEL not equal to 000.

30125275

FIGURE 13. DS92LV0412 Output State Diagram

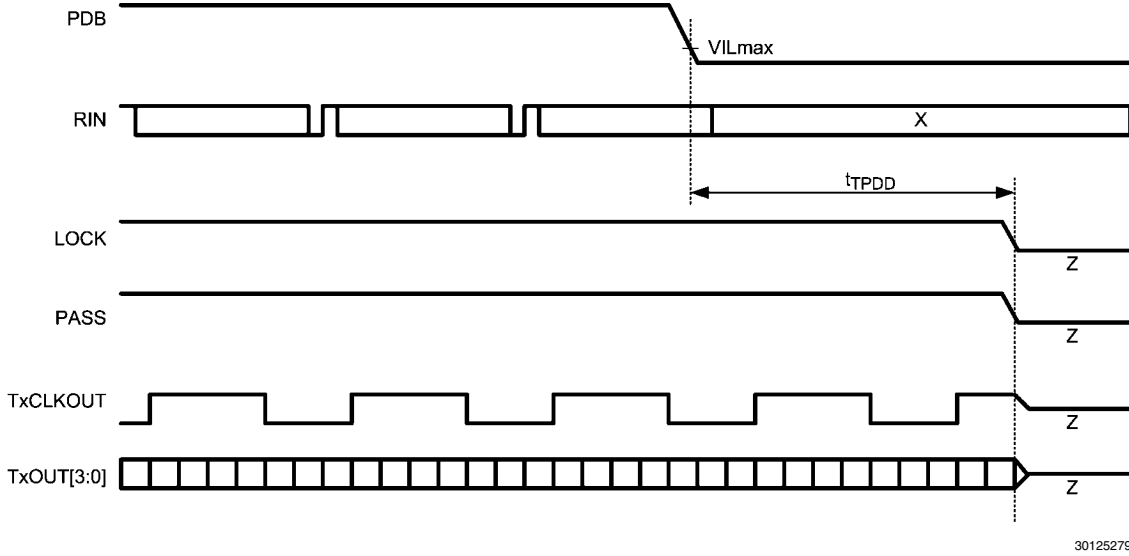

FIGURE 14. DS92LV0412 Power Down Delay

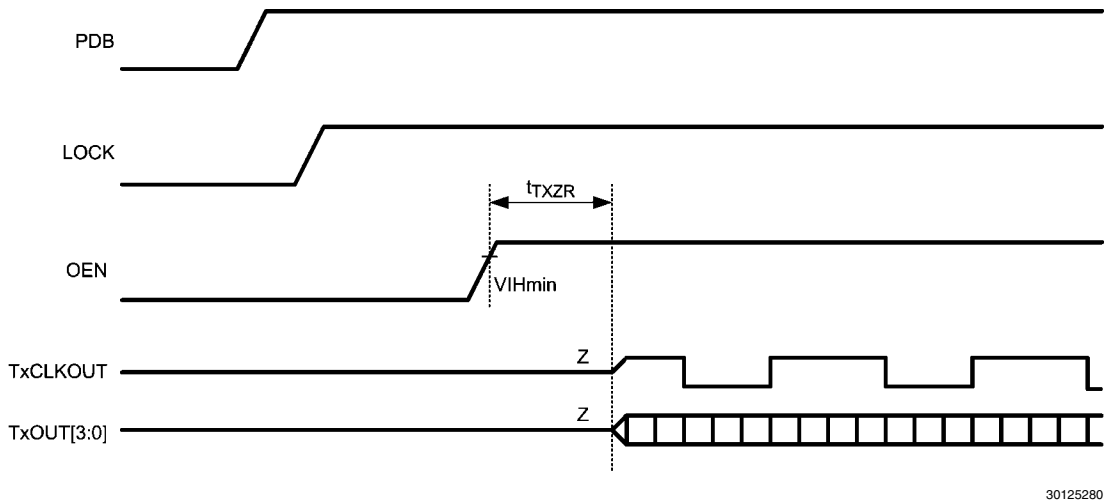

FIGURE 15. DS92LV0412 Enable Delay

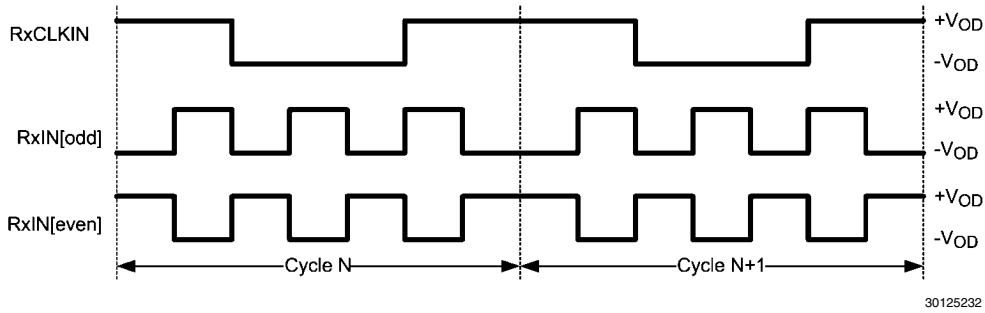
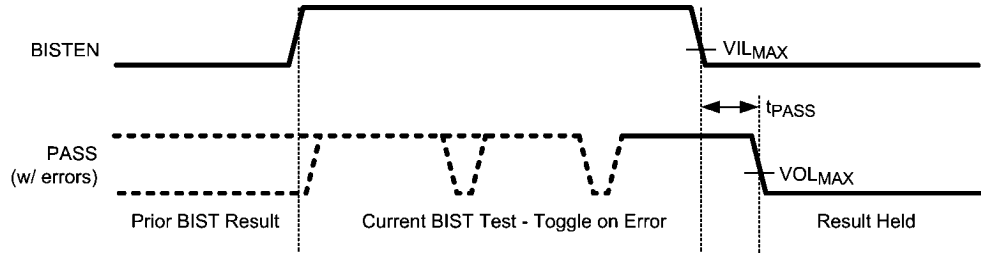
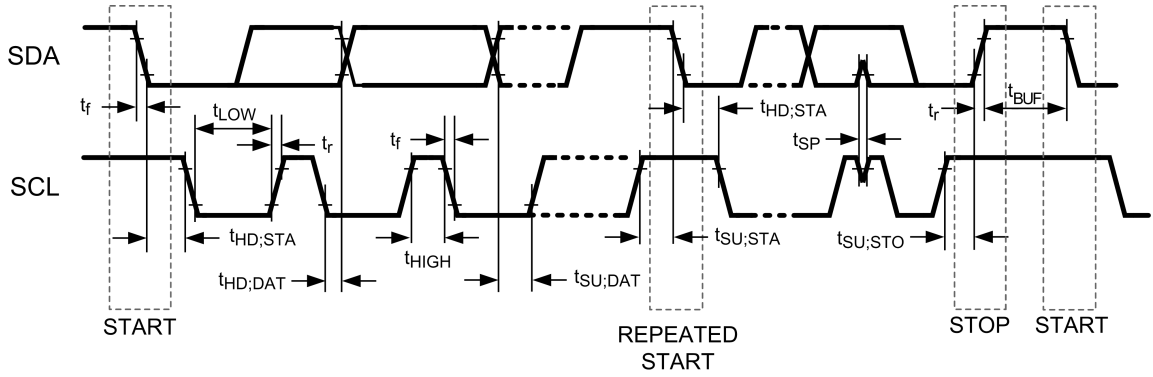

FIGURE 16. Checkerboard Data Pattern



30125252

FIGURE 17. BIST PASS Waveform



30125236

FIGURE 18. Serial Control Bus Timing Diagram

Functional Description

The DS92LV0411 / DS92LV0412 chipset transmits and receives 24-bits of data and 3 control signals, formatted as Channel Link LVDS data, over a single serial CML pair operating at 280 Mbps to 2.1 Gbps serial line rate. The serial stream contains an embedded clock, video control signals and is DC-balance to enhance signal quality and supports AC coupling.

The Des can attain lock to a data stream without the use of a separate reference clock source, which simplifies system complexity and overall cost. The Des also synchronizes to the Ser regardless of the data pattern, delivering true automatic “plug and lock” performance. It can lock to the incoming serial stream without the need of special training patterns or sync characters. The Des recovers the clock and data by extracting the embedded clock information, validating and then deserializing the incoming data stream providing a parallel Channel Link LVDS bus to the display, ASIC, or FPGA.

The DS92LV0411 / DS92LV0412 chipset can operate with up to 24 bits of raw data with three slower speed control bits encoded within the serial data stream. For applications that require less the maximum 24 pclk speed bit spaces, the user will need to ensure that all unused bit spaces or parallel LVDS channels are set to valid logic states, as all parallel lanes and 27 bit spaces will always be sampled.

Block Diagrams for the chipset are shown at the beginning of this datasheet.

Parallel LVDS Data Transfer

The DS92LV0411/DS92LV0412 can be configured to accept/transmit 24-bit data with 2 different mapping schemes: The normal Channel Link LVDS format (MSBs on LVDS channel 3) can be selected by configuring the MAPSEL pin to HIGH. See Figure 13 for the normal Channel Link LVDS mapping. An alternate mapping scheme is available (LSBs on LVDS channel 3) by configuring the MAPSEL pin to LOW. See Figure 14 for the alternate LVDS mapping. The mapping schemes can also be selected by register control.

The alternate mapping scheme is useful in some applications where the receiving system, typically a display, requires that the LSBs for the 24-bit color data be sent on LVDS channel 3.

Serial Data Transfer

The DS92LV0411 transmits a pixel of data in the following format: C1 and C0 represent the embedded clock in the serial stream. C1 is always HIGH and C0 is always LOW. b[23:0] contain the scrambled RGB data. DCB is the DC-Balanced control bit. DCB is used to minimize the short and long-term DC bias on the signal lines. This bit determines if the data is unmodified or inverted. DCA is used to validate data integrity in the embedded data stream and can also contain encoded control (VS,HS,DE). Both DCA and DCB coding schemes are generated by the DS92LV0411 and decoded by the paring deserializer automatically. [Figure 19](#) illustrates the serial stream per PCLK cycle.

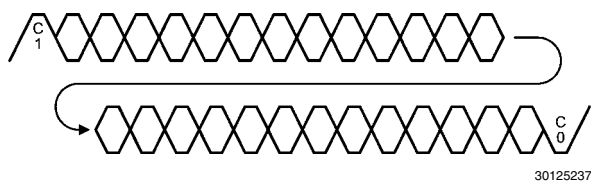

FIGURE 19. Channel Link II Serial Stream

OPERATING MODES AND BACKWARD COMPATIBILITY (CONFIG[1:0])

The DS92LV0411 and DS92LV0412 are backward compatible with previous generations of National Ser/Des. Configuration modes are provided for backwards compatibility with the DS90C241/DS90C124 and also the DS90UR241/DS90UR124 and DS99R241/DS99R124 by setting the respective mode with the CONFIG[1:0] pins as shown in [Table 1](#) and [Table 2](#). The selection also determine whether the Video Control Signal filter feature is enabled or disabled in Normal mode. Backward compatibility modes are selectable through the control pins only. The Control Signal Filter can be selected by pin or through register programming.

TABLE 1. DS92LV0411 Configuration Modes

CON FIG1	CON FIG0	Mode	Des Device
L	L	Normal Mode, Control Signal Filter disabled	DS92LV0412, DS92LV2412
L	H	Normal Mode, Control Signal Filter enabled	DS92LV0412, DS92LV2412
H	L	Backwards Compatible	DS90UR124, DS99R124
H	H	Backwards Compatible	DS90C124

TABLE 2. DS92LV0412 Configuration Modes

CON FIG1	CON FIG0	Mode	Des Device
L	L	Normal Mode, Control Signal Filter disabled	DS92LV0411, DS92LV2411
L	H	Normal Mode, Control Signal Filter enabled	DS92LV0411, DS92LV2411
H	L	Backwards Compatible	DS90UR241, DS99R421
H	H	Backwards Compatible	DS90C241

Video Control Signal Filter

The three control bits can be used to communicate any low speed signal. The most common use for these bits is in the display or machine vision applications. In a display application these bits are typically assigned as: Bit 26 – DE, Bit 24 – HS, Bit 25 – VS. In the machine vision standard, Camera Link, these bits are typically assigned: Bit 26 – DVAL, Bit 24 – LVAL, Bit 25 – FVAL.

When operating the devices in Normal Mode, the Video Control Signals (DE, HS, VS) have the following restrictions:

- Normal Mode with Control Signal Filter Enabled: DE and HS — Only 2 transitions per 130 clock cycles are transmitted, the transition pulse must be 3 PCLK or longer.
- Normal Mode with Control Signal Filter Disabled: DE and HS — Only 2 transitions per 130 clock cycles are transmitted, no restriction on minimum transition pulse.
- VS — Only 1 transition per 130 clock cycles are transmitted, minimum pulse width is 130 clock cycles.

Video Control Signals are defined as low frequency signals with limited transitions. Glitches of a control signal can cause a visual display error. This feature allows for the chipset to validate and filter out any high frequency noise on the control signals. See [Figure 20](#).

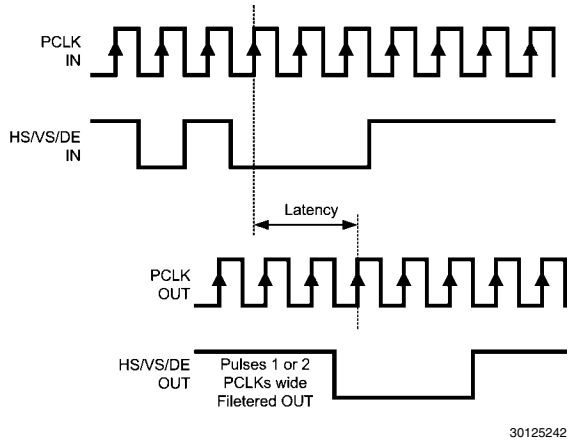

30125242

FIGURE 20. Video Control Signal Filter Waveform

BIT MAPPING SELECT

The DS92LV0411 and DS92LV0412 can be configured to accept the LVDS parallel data with 2 different mapping schemes: LSBs on RxIN[3] shown in Figure 21 or MSBs on RxIN[3] shown in Figure 22. The user selects which mapping scheme is controlled by MAPSEL pin or by Register.

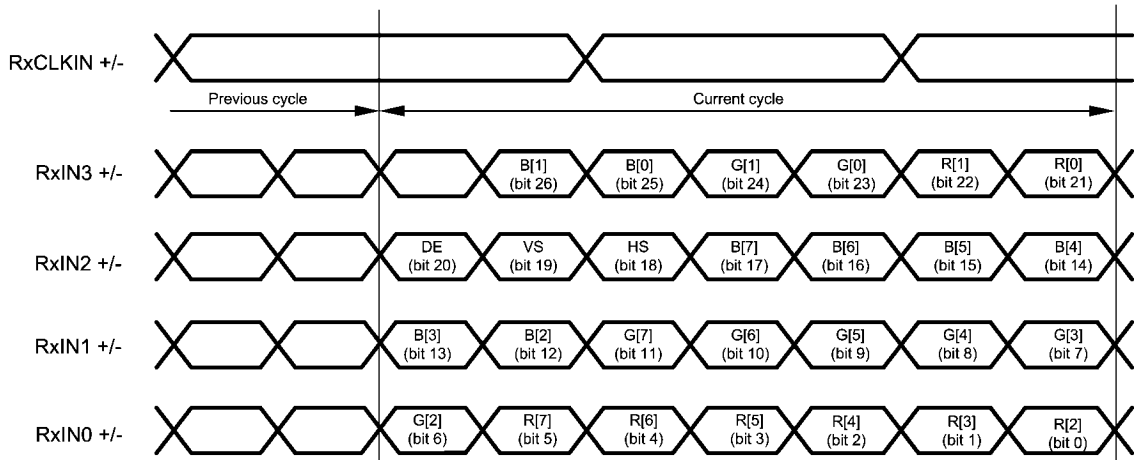

30125265

FIGURE 21. 8-bit Channel Link Mapping: LSB's on RxIN3

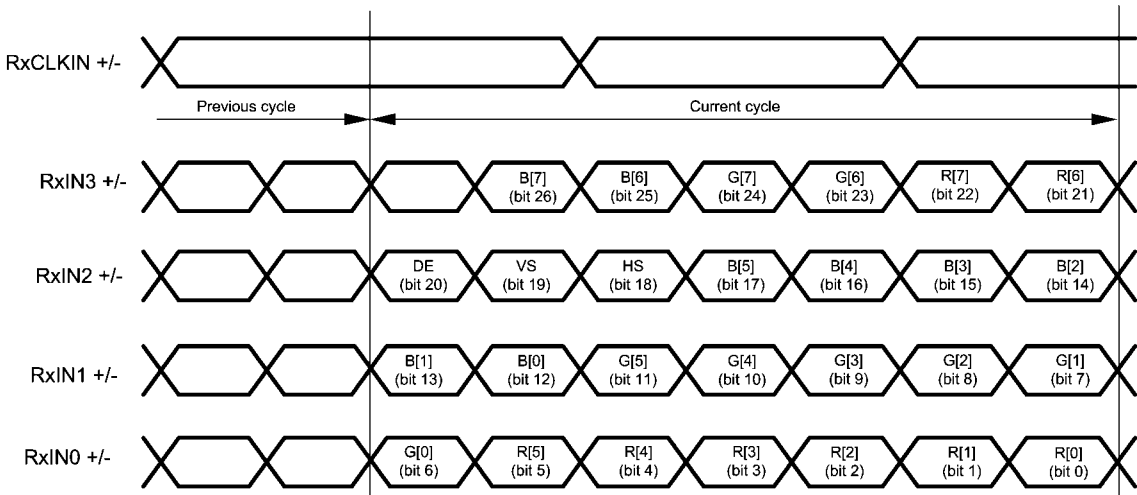

30125266

FIGURE 22. 8-bit Channel Link Mapping: MSB's on RxIN3

SERIALIZER Functional Description

The Ser converts a Channel Link LVDS clock and data bus to a single serial output data stream, and also acts as a signal generator for the chipset Built In Self Test (BIST) mode. The device can be configured via external pins or through the optional serial control bus. The Ser features enhanced signal quality on the link by supporting: a selectable VOD level, a selectable de-emphasis signal conditioning and also the Channel Link II data coding that provides randomization, scrambling, and DC Balancing of the data. The Ser includes multiple features to reduce EMI associated with display data transmission. This includes the randomization and scrambling of the serial data and also the system spread spectrum clock support. The Ser features power saving features with a sleep mode, auto stop clock feature, and optional 1.8 V or 3.3V I/O compatibility.

See also the Functional Description of the chipset's serial control bus and BIST modes.

EMI Reduction Features

Data Randomization & Scrambling

Channel Link II Ser / Des feature a 3 step encoding process which enables the use of AC coupled interconnects and also helps to manage EMI. The serializer first passes the parallel data through a scrambler which randomizes the data. The randomized data is then DC balanced. The DC balanced and randomized data then goes through a bit shuffling circuit and is transmitted out on the serial line. This encoding process helps to prevent static data patterns on the serial stream. The resulting frequency content of the serial stream ranges from the parallel clock frequency to the nyquist rate. For example, if the Ser / Des chip set is operating at a parallel clock frequency of 50 MHz, the resulting frequency content of serial stream ranges from 50 MHz to 700 MHz ($50 \text{ MHz} * 28 \text{ bits} = 1.4 \text{ Gbps} / 2 = 700 \text{ MHz}$).

Ser — Spread Spectrum Compatibility

The RxCLKIN of the Channel Link input is capable of tracking spread spectrum clocking (SSC) from a host source. The RxCLKIN will accept spread spectrum tracking up to 35kHz modulation and ± 0.5 , ± 1 or $\pm 2\%$ deviations (center spread). The maximum conditions for the RxCLKIN input are: a modulation frequency of 35kHz and amplitude deviations of $\pm 2\%$ (4% total).

Ser — Integrated Signal Conditioning Features

Ser — VOD Select (VODSEL)

The DS92LV0411 differential output voltage may be increased by setting the VODSEL pin High. When VODSEL is Low, the DC VOD is at the standard (default) level. When VODSEL is High, the DC VOD is increased in level. The increased VOD is useful in extremely high noise environments and also on extra long cable length applications. When using de-emphasis it is recommended to set VODSEL = H to avoid excessive signal attenuation especially with the larger de-emphasis settings. This feature may be controlled by the external pin or by register.

TABLE 3. Ser — Differential Output Voltage

Input	Effect	
	VOD mV	VOD mVp-p
VODSEL H	± 420	840
VODSEL L	± 280	560

Ser — De-Emphasis (De-Emph)

The De-Emph pin controls the amount of de-emphasis beginning one full bit time after a logic transition that the device drives. This is useful to counteract loading effects of long or lossy cables. This pin should be left open for standard switching currents (no de-emphasis) or if controlled by register. De-emphasis is selected by connecting a resistor on this pin to ground, with R value between 0.5 k Ω to 1 M Ω , or by register setting. When using De-Emphasis it is recommended to set VODSEL = H.

TABLE 4. De-Emphasis Resistor Value

Resistor Value (k Ω)	De-Emphasis Setting
Open	Disabled
0.6	- 12 dB
1.0	- 9 dB
2.0	- 6 dB
5.0	- 3 dB

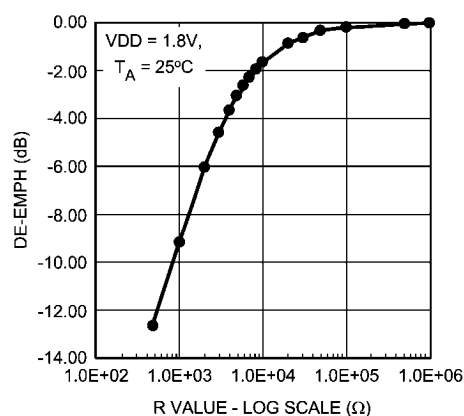

30125260

FIGURE 23. De-Emph vs. R value

Power Saving Features

Ser — Power Down Feature (PDB)

The DS92LV0411 has a PDB input pin to ENABLE or POWER DOWN the device. This pin is controlled by the host and is used to save power, disabling the link when the display is not needed. In the POWER DOWN mode, the high-speed driver outputs are both pulled to VDD and present a 0V VOD state. Note – in POWER DOWN, the optional Serial Bus Control Registers are **RESET**.

Ser — Stop Clock Feature

The DS92LV0411 will enter a low power SLEEP state when the RxCLKIN is stopped. A STOP condition is detected when the input clock frequency is less than 3 MHz. The clock should be held at a static Low or high state. When the RxCLKIN starts again, the device will then lock to the valid input RxCLKIN and then transmits the RGB data to the deserializer. Note – in STOP CLOCK SLEEP, the optional Serial Bus Control Registers values are **RETAINED**.

1.8V or 3.3V VDDIO Operation

The DS92LV0411 parallel control bus can operate with 1.8 V or 3.3 V levels (V_{DDIO}) for host compatibility. The 1.8 V levels will offer a system power savings.

Optional Serial Bus Control

Please see the following section on the optional Serial Bus Control Interface.

Optional BIST Mode

Please see the following section on the chipset BIST mode for details.

DESERIALIZER Functional Description

The Des converts a single input serial data stream to a wide parallel output bus, and also provides a signal check for the chipset Built In Self Test (BIST) mode. The device can be configured via external pins and strap pins or through the optional serial control bus. The Des features enhance signal quality on the link with an integrated equalizer on the serial input and Channel Link II data encoding which provides randomization, scrambling, and DC balancing of the data. The Des includes multiple features to reduce EMI associated with data transmission. This includes the randomization and scrambling of the data, the output spread spectrum clock generation (SSCG) support and output clock and data slew rate select. The Des features power saving features with a power down mode, and optional LVCMOS (1.8 V) interface compatibility.

Oscillator Output — Optional

The DS92LV0412 provides an optional TxCLKOUT when the input clock (serial stream) has been lost. This is based on an internal oscillator. The frequency of the oscillator may be selected. This feature may be controlled by the external pin or through the registers.

Clock-DATA RECOVERY STATUS FLAC (LOCK), OUTPUT ENABLE (OEN) and OUTPUT STATE SELECT (OSS_SEL)

When PDB is driven HIGH, the CDR PLL begins locking to the serial input, LOCK is LOW and the Channel Link interface state is determined by the state of the OSS_SEL pin.

After the DS92LV0412 completes its lock sequence to the input serial data, the LOCK output is driven HIGH, indicating valid data and clock recovered from the serial input is available on the Channel Link outputs. The TxCLKOUT output is held at its current state at the change from OSC_CLK (if this is enabled via OSC_SEL) to the recovered clock (or vice versa). Note that the Channel Link outputs may be held in an inactive state (TRI-STATE®) through the use of the Output Enable pin (OEN).

If there is a loss of clock from the input serial stream, LOCK is driven LOW and the state of the outputs are based on the OSS_SEL setting (configuration pin or register).

TABLE 5. Des Output State Table

INPUTS			OUTPUTS	
PDB	OEN	OSS_SEL	LOCK	OTHER OUTPUTS
L	X	X	X	TxCLKOUT is TRI-STATE® TxOUT[3:0] are TRI-STATE® PASS is TRI-STATE®
L	X	L	L	TxCLKOUT is TRI-STATE® TxOUT[3:0] are TRI-STATE® PASS is HIGH
H	L	H	L	TxCLKOUT is TRI-STATE® TxOUT[3:0] are TRI-STATE® PASS is TRI-STATE®
H	H	H	L	TxCLKOUT is TRI-STATE® or OSC Output through Register bit TxOUT[3:0] are TRI-STATE® PASS is TRI-STATE®
H	L	X	H	TxCLKOUT is TRI-STATE® TxOUT[3:0] are TRI-STATE® PASS is HIGH
H	H	X	H	TxCLKOUT is Active TxOUT[3:0] are Active PASS is Active (Normal operating mode)

Des — Integrated Signal Conditioning Features — Des

Des — Common Mode Filter Pin (CMF) — Optional

The Des provides access to the center tap of the internal termination. A capacitor may be placed on this pin for additional common-mode filtering of the differential pair. This can be useful in high noise environments for additional noise rejection capability. A 0.1µF capacitor may be connected to this pin to Ground.

Des — Input Equalizer Gain (EQ)

The Des can enable receiver input equalization of the serial stream to increase the eye opening to the Des input. Note this function cannot be seen at the RxIN+/- input. The equalization feature may be controlled by the external pin or by register.

TABLE 6. Receiver Equalization Configuration Table

EQ (Strap Option)	Effect
L	~1.5 dB
H	~13 dB

EMI Reduction Features

Des — VOD Select (VODSEL)

The differential output voltage of the Channel Link interface is controlled by the VODSEL input.

TABLE 7. Des — Differential Output Voltage Table

VODSEL	Result
L	VOD is 250 mV TYP (500 mVp-p)
H	VOD is 400 mV TYP (800 mVp-p)

Des — SSCG Generation — Optional

The Des provides an internally generated spread spectrum clock (SSCG) to modulate its outputs. Both clock and data outputs are modulated. This will aid in lower system EMI. Output SSCG deviations to $\pm 2\%$ (4% total) at up to 100 kHz modulations is available. See Table . This feature may be controlled by external STRAP pins or by register.

TABLE 8. SSCG Configuration (LF_MODE = L) — Des Output

SSC[3:0] Inputs LF_MODE = L (20 — 55 MHz)				Result	
SSC3	SSC2	SSC1	SSC0	fdev (%)	fmod (kHz)
L	L	L	L	N/A	CLK/2168
L	L	L	H	± 0.5	
L	L	H	L	± 1.0	
L	L	H	H	± 1.5	
L	H	L	L	± 2.0	
L	H	L	H	± 0.5	CLK/1300
L	H	H	L	± 1.0	
L	H	H	H	± 1.5	
H	L	L	L	± 2.0	
H	L	L	H	± 0.5	
H	L	H	L	± 1.0	
H	L	H	H	± 1.5	
H	H	L	L	± 2.0	
H	H	L	H	± 0.5	CLK/650
H	H	H	L	± 1.0	
H	H	H	H	± 1.5	

TABLE 9. SSCG Configuration (LF_MODE = H) — Des Output

SSC[3:0] Inputs LF_MODE = H (5 — 20 MHz)				Result	
SSC3	SSC2	SSC1	SSC0	fdev (%)	fmod (kHz)
L	L	L	L	N/A	CLK/620
L	L	L	H	±0.5	
L	L	H	L	±1.0	
L	L	H	H	±1.5	
L	H	L	L	±2.0	
L	H	L	H	±0.5	CLK/370
L	H	H	L	±1.0	
L	H	H	H	±1.5	
H	L	L	L	±2.0	
H	L	L	H	±0.5	CLK/258
H	L	H	L	±1.0	
H	L	H	H	±1.5	
H	H	L	L	±2.0	
H	H	L	H	±0.5	CLK/192
H	H	H	L	±1.0	
H	H	H	H	±1.5	

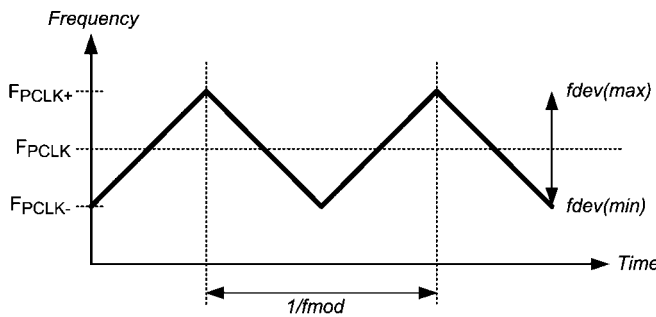

30125273
FIGURE 24. SSCG Waveform

Power Saving Features

Des — Power Down Feature (PDB)

The DS92LV0412 has a PDB input pin to ENABLE or POWER DOWN the device. This pin is controlled by the host and is used to save power, disabling the Des when the display is not needed. An auto detect mode is also available. In this mode, the PDB pin is tied HIGH and the Des will enter POWER DOWN when the serial stream stops. When the serial stream starts up again, the Des will lock to the input stream and assert the LOCK pin and output valid data. In the POWER DOWN mode, the LVDS data and clock output states are determined by the OSS_SEL status. Note – in POWER DOWN, the optional Serial Bus Control Registers are **RESET**.

Des — Stop Stream SLEEP Feature

The DS92LV0412 will enter a low power SLEEP state when the input serial stream is stopped. A STOP condition is detected when the embedded clock bits are not present. When the serial stream starts again, the Des will then lock to the incoming signal and recover the data. Note – in STOP CLOCK SLEEP, the optional Serial Bus Control Registers values are **RETAINED**.

1.8V or 3.3V VDDIO Operation

The DS92LV0412 parallel control bus can operate with 1.8 V or 3.3 V levels (V_{DDIO}) for host compatibility. The 1.8 V levels will offer a system power savings.

Built In Self Test (BIST)

An optional At-Speed Built In Self Test (BIST) feature supports the testing of the high-speed serial link. This is useful in the prototype stage, equipment production, in-system test and also for system diagnostics. In the BIST mode only a input clock is required along with control to the Ser and Des BISTEN input pins. The Ser outputs a test pattern (PRBS7) and drives the link at speed. The Des detects the PRBS7 pattern and monitors it for errors. A PASS output pin toggles to flag any payloads that are received with 1 to 24 errors. Upon completion of the test, the result of the test is held on the PASS output until reset (new BIST test or Power Down). A high on PASS indicates NO ERRORS were detected. A Low on PASS indicates one or more errors were detected. The duration of the test is controlled by the pulse width applied to the Des BISTEN pin.

Inter-operability is supported between this Channel Link II device and all Channel Link II generations (Gen 1/2/3) — see respective datasheets for details on entering BIST mode and control.

Sample BIST Sequence

See [Figure 25](#) for the BIST mode flow diagram.

Step 1: Place the serializer in BIST Mode by setting Ser BISTEN = H. The BIST Mode is enabled via the BISTEN pin. An RxCLKIN is required for all the Ser options. When the deserializer detects the BIST mode pattern and command the parallel data and control signal outputs are shut off.

Step 2: Place the deserializer in BIST mode by setting the BISTEN = H. The Des is now in the BIST mode and checks the incoming serial payloads for errors. If an error in the payload (1 to 24) is detected, the PASS pin will switch low for one half of the clock period. During the BIST test, the PASS output can be monitored and counted to determine the payload error rate.

Step 3: To Stop the BIST mode, the deserializer BISTEN pin is set Low. The deserializer stops checking the data and the final test result is held on the PASS pin. If the test ran error free, the PASS output will be High. If there was one or more errors detected, the PASS output will be Low. The PASS output state is held until a new BIST is run, the device is RESET, or Powered Down. The BIST duration is user controlled by the duration of the BISTEN signal.

Step 4: To return the link to normal operation, the ser and des BISTEN input are set Low. The Link returns to normal operation.

[Figure 26](#) shows the waveform diagram of a typical BIST test for two cases. Case 1 is error free, and Case 2 shows one

with multiple errors. In most cases it is difficult to generate errors due to the robustness of the link (differential data transmission etc.), thus they may be introduced by greatly extending the cable length, faulting the interconnect, reducing signal condition enhancements (De-Emphasis, VODSEL, or deserializer Equalization).

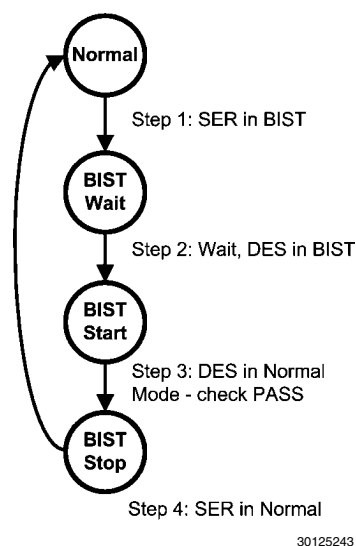

FIGURE 25. BIST Mode Flow Diagram

BER Calculations

It is possible to calculate the approximate Bit Error Rate (BER). The following is required:

- Pixel Clock Frequency (MHz)
- BIST Duration (seconds)
- BIST test Result (PASS)

The BER is less than or equal to one over the product of 24 times the RxCLKIN rate times the test duration. If we assume a 65MHz RxCLKIN, a 10 minute (600 second) test, and a PASS, the BERT is $\leq 1.07 \times 10^{-12}$

The BIST mode runs a check on the data payload bits. The LOCK pin also provides a link status. If the recovery of the C0 and C1 bits does not reconstruct the expected clock signal, the LOCK pin will switch Low. The combination of the LOCK and At-Speed BIST PASS pin provides a powerful tool for system evaluation and performance monitoring.

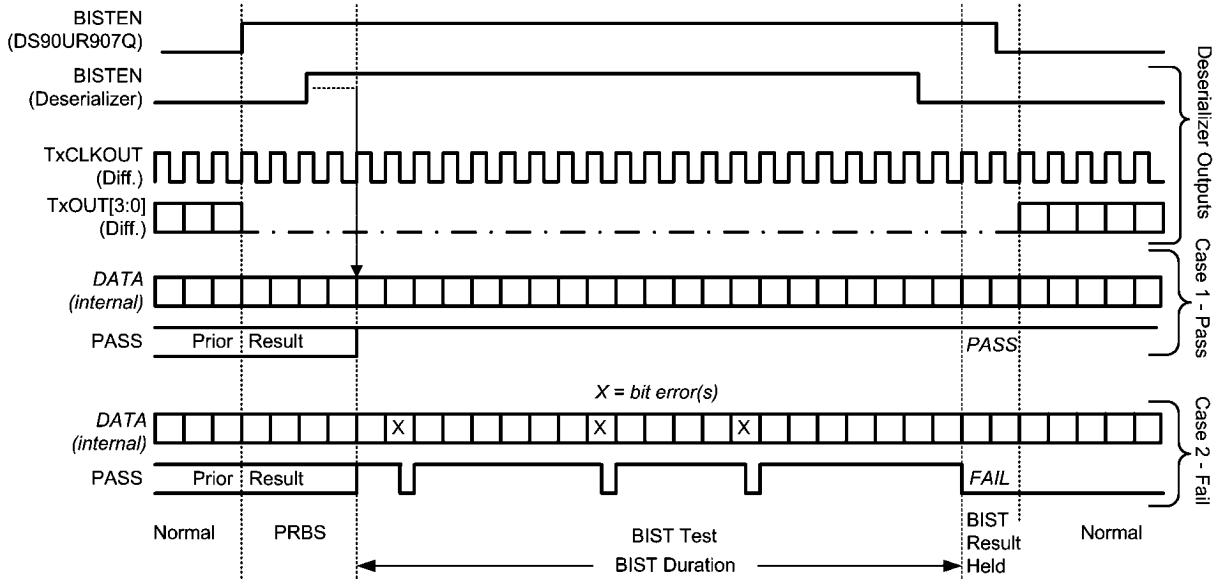

30125264

FIGURE 26. BIST Waveforms

Optional Serial Bus Control

The DS92LV0411 and DS92LV0412 may be configured by the use of a serial control bus that is I2C protocol compatible. By default, the I2C reg_0x00'h is set to 00'h and all configuration is set by control/strap pins. A write of 01'h to reg_0x00'h will enable/allow configuration by registers; this will override the control/strap pins. Multiple devices may share the serial control bus since multiple addresses are supported. See [Figure 27](#).

The serial bus is comprised of three pins. The SCL is a Serial Bus Clock Input. The SDA is the Serial Bus Data Input / Output signal. Both SCL and SDA signals require an external pull up resistor to V_{DDIO}. For most applications a 4.7 kΩ pull up resistor to 3.3V may be used. The resistor value may be adjusted for capacitive loading and data rate requirements. The signals are either pulled High, or driven Low.

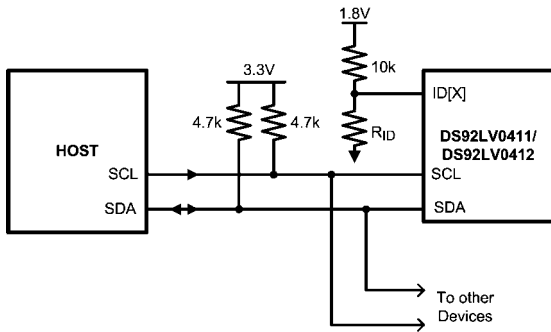

30125241

FIGURE 27. Serial Control Bus Connection

The third pin is the ID[X] pin. This pin sets one of five possible device addresses. Three different connections are possible. The pin may be tied to ground. The pin may be pulled to V_{DD} (1.8V, NOT V_{DDIO}) with a 10 kΩ resistor. Or a 10 kΩ pull up resistor (to V_{DD} 1.8V, NOT V_{DDIO}) and a pull down resistor

of the recommended value to set other three possible addresses may be used. See [Table 10](#).

The Serial Bus protocol is controlled by START, START-Repeated, and STOP phases. A START occurs when SCL transitions Low while SDA is High. A STOP occurs when SDA transition High while SCL is also HIGH. See [Figure 28](#)

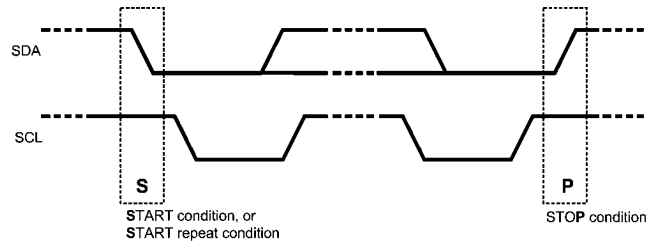

30125251

FIGURE 28. START and STOP Conditions

To communicate with a remote device, the host controller (master) sends the slave address and listens for a response from the slave. This response is referred to as an acknowledge bit (ACK). If a slave on the bus is addressed correctly, it Acknowledges (ACKs) the master by driving the SDA bus low. If the address doesn't match a device's slave address, it Not-acknowledges (NACKs) the master by letting SDA be pulled High. ACKs also occur on the bus when data is being transmitted. When the master is writing data, the slave ACKs after every data byte is successfully received. When the master is reading data, the master ACKs after every data byte is received to let the slave know it wants to receive another data byte. When the master wants to stop reading, it NACKs after the last data byte and creates a stop condition on the bus. All communication on the bus begins with either a Start condition or a Repeated Start condition. All communication on the bus ends with a Stop condition. A READ is shown in [Figure 29](#) and a WRITE is shown in [Figure 30](#).

If the Serial Bus is not required, the three pins may be left open (NC).

TABLE 10. ID[x] Resistor Value – DS92LV0411

Resistor RID kΩ	Address 7'b	Address 8'b 0 appended (WRITE)
0.47	7b' 110 1001 (h'69)	8b' 1101 0010 (h'D2)
2.7	7b' 110 1010 (h'6A)	8b' 1101 0100 (h'D4)
8.2	7b' 110 1011 (h'6B)	8b' 1101 0110 (h'D6)
Open	7b' 110 1110 (h'6E)	8b' 1101 1100 (h'DC)

TABLE 11. ID[x] Resistor Value – DS92LV0412

Resistor RID kΩ	Address 7'b	Address 8'b 0 appended (WRITE)
0.47	7b' 111 0001 (h'71)	8b' 1110 0010 (h'E2)
2.7	7b' 111 0010 (h'72)	8b' 1110 0100 (h'E4)
8.2	7b' 111 0011 (h'73)	8b' 1110 0110 (h'E6)
Open	7b' 111 0110 (h'76)	8b' 1110 1100 (h'EC)

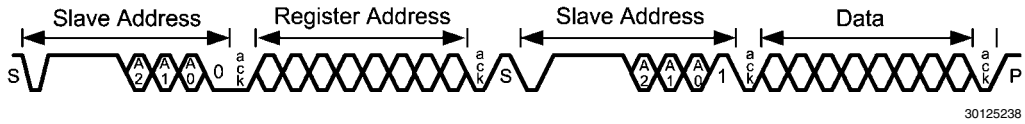

FIGURE 29. Serial Control Bus — READ

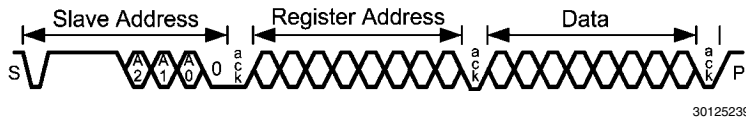

FIGURE 30. Serial Control Bus — WRITE

TABLE 12. DS92LV0411 SERIALIZER — Serial Bus Control Registers

ADD (dec)	ADD (hex)	Register Name	Bit(s)	R/W	Default (bin)	Function	Description
0	0	Ser Config 1	7	R/W	0	Reserved	Reserved
			6	R/W	0	MAPSEL	0: LSB on RxIN3 1: MSB on RxIN3
			5	R/W	0	Reserved	Reserved
			4	R/W	0	VODSEL	0: Low 1: High
			3:2	R/W	00	CONFIG	00: Control Signal Filter Disabled 01: Control Signal Filter Enabled 10: Reserved 11: Reserved
			1	R/W	0	SLEEP	Note – not the same function as PowerDown (PDB) 0: normal mode 1: Sleep Mode – Register settings retained.
			0	R/W	0	REG	0: Configurations set from control pins 1: Configuration set from registers (except I2C_ID)
1	1	Device ID	7	R/W	0	REG ID	0: Address from ID[X] Pin 1: Address from Register
			6:0	R/W	1101 000	ID[X]	Serial Bus Device ID, IDs are: 7b '1101 001 (h'69) 7b '1101 010 (h'6A) 7b '1101 011 (h'6B) 7b '1101 110 (h'6E) All other addresses are Reserved .
2	2	De-Emphasis Control	7:5	R/W	000	De-E Setting	000: set by external Resistor 001: -1 dB 010: -2 dB 011: -3.3 dB 100: -5 dB 101: -6.7 dB 110: -9 dB 111: -12 dB
			4	R/W	0	De-E EN	0: De-Emphasis Enabled 1: De-Emphasis Disabled
			3:0	R/W	000	Reserved	Reserved

TABLE 13. DS92LV0412 DESERIALIZER — Serial Bus Control Registers

ADD (dec)	ADD (hex)	Register Name	Bit(s)	R/W	Default (bin)	Function	Description
0	0	Des Config 1	7	R/W	0	LFMODE	SSCG Mode — low frequency support 0: 20 to 65 MHz Operation 1: 10 to 20 MHz Operation
			6	R/W	0	MAPSEL	Channel Link Map Select 0: LSB on TxOUT3+/- 1: MSB on TxOUT3+/-
			5	R/W	0	Reserved	Reserved
			4	R/W	0	Reserved	Reserved
			3:2	R/W	00	CONFIG	00: Control Signal Filter Disabled 01: Control Signal Filter Enabled 10: Reserved 11: Reserved
			1	R/W	0	SLEEP	Note – not the same function as PowerDown (PDB) 0: normal mode 1: Sleep Mode – Register settings retained.
			0	R/W	0	REG Control	0: Configurations set from control pins 1: Configuration set from registers (except I2C_ID)
1	1	Device ID	7	R/W	0	REG ID	0: Address from ID[X] Pin 1: Address from Register
			6:0	R/W	1110 000	ID[X]	Serial Bus Device ID, IDs are: 7b' 111 0001 (h'71) 7b' 111 0010 (h'72) 7b' 111 0011 (h'73) 7b' 111 0110 (h'76) All other addresses are Reserved .
2	2	Des Features 1	7	R/W	0	OEN	Output Enable Input Table 5
			6	R/W	0	OSS_SEL	Output Sleep State Select Table 5
			5:4	R/W	00	Reserved	Reserved
			3	R/W	0	VODSEL	LVDS Driver Output Voltage Select 0: LVDS VOD is ± 250 mV, 500 mVp-p (typ) 1: LVDS VOD is ± 400 mV, 800 mVp-p (typ)
			2:0	R/W	000	OSC_SEL	000: OFF 001: RESERVED 010: 25 MHz $\pm 40\%$ 011: 16.7 MHz $\pm 40\%$ 100: 12.5 MHz $\pm 40\%$ 101: 10 MHz $\pm 40\%$ 110: 8.3 MHz $\pm 40\%$ 111: 6.3MHz $\pm 40\%$

ADD (dec)	ADD (hex)	Register Name	Bit(s)	R/W	Default (bin)	Function	Description
3	3	Des Features 2	7:5	R/W	000	EQ Gain	000: ~-1.625 dB 001: ~-3.25 dB 010: ~-4.87 dB 011: ~-6.5 dB 100: ~-8.125 dB 101: ~-9.75 dB 110: 11.375 dB 111: 13 dB
			4	R/W	0	EQ Enable	0: EQ = disabled 1: EQ = enabled
			3	R/W	0	Reserved	Reserved
			2:0	R/W	000	SSC	IF LFMODE = 0 then: 000: SSCG OFF 001: fdev = ±0.9%, fmod = CLK/2168 010: fdev = ±1.2%, fmod = CLK/2168 011: fdev = ±1.9%, fmod = CLK/2168 100: fdev = ±2.3%, fmod = CLK/2168 101: fdev = ±0.7%, fmod = CLK/21300 110: fdev = ±1.3%, fmod = CLK/1300 111: fdev = ±1.57%, fmod = CLK/1300 IF LFMODE = 1, then: 001: fdev = ±0.7%, fmod = CLK/625 010: fdev = ±1.3%, fmod = CLK/625 011: fdev = ±1.8%, fmod = CLK/625 100: fdev = ±2.2%, fmod = CLK/625 101: fdev = ±0.7%, fmod = CLK/385 110: fdev = ±1.2%, fmod = CLK/385 111: fdev = ±1.7%, fmod = CLK/385

Applications Information

DISPLAY APPLICATION

The DS92LV0411 and DS92LV0412 chipset is intended for interface between a host (graphics processor) and a Display. It supports an 24-bit color depth (RGB888) and up to 1024 X 768 display formats. In a RGB888 application, 24 color bits (R[7:0], G[7:0], B[7:0]), Pixel Clock (PCLK) and three control bits (VS, HS and DE) are supported across the serial link with PCLK rates from 5 to 50 MHz. The chipset may also be used in 18-bit color applications. In this application three to six general purpose signals may also be sent from host to display.

DS92LV0411 TYPICAL APPLICATION CONNECTION

Figure 31 shows a typical application of the DS92LV0411 for a 50 MHz 24-bit Color Display Application. The LVDS inputs require external 100 ohm differential termination resistors. The CML outputs require 0.1 μF AC coupling capacitors to the

line. The line driver includes internal termination. Bypass capacitors are placed near the power supply pins. At a minimum, four 0.1 μF capacitors and a 4.7 μF capacitor should be used for local device bypassing. System GPO (General Purpose Output) signals control the PDB and BISTEN pins. The application assumes the companion deserializer (DS92LV0412) therefore the configuration pins are also both tied Low. In this example the cable is long, therefore the VODSEL pin is tied High and a De-Emphasis value is selected by the resistor R1. The interface to the host is with 1.8 V LVCMOS levels, thus the VDDIO pin is connected also to the 1.8V rail. The Optional Serial Bus Control is not used in this example, thus the SCL, SDA and ID[x] pins are left open. A delay cap is placed on the PDB signal to delay the enabling of the device until power is stable. Bypass capacitors are placed near the power supply pins. Ferrite beads are placed on the power lines for effective noise suppression.

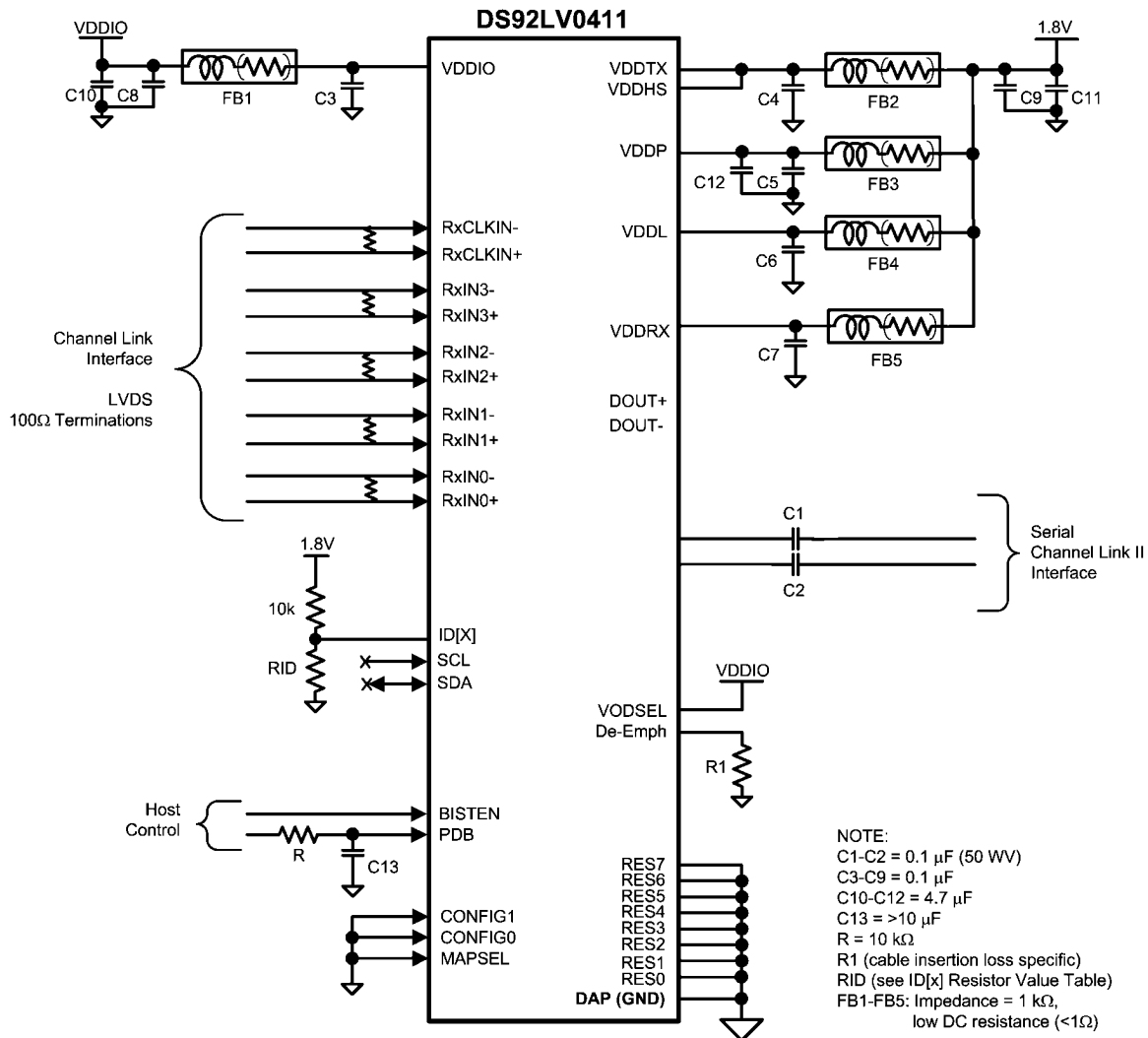

30125244

FIGURE 31. DS92LV0411 Typical Connection Diagram

DS92LV0412 TYPICAL APPLICATION CONNECTION

shows a typical application of the DS92LV0412 for a 50 MHz 24-bit Color Display Application. The CML inputs require 0.1

μF AC coupling capacitors to the line. The line driver includes internal termination. Bypass capacitors are placed near the power supply pins. At a minimum, four 0.1 μF capacitors and

a 4.7 μF capacitor should be used for local device bypassing. System GPO (General Purpose Output) signals control the PDB and BISTEN pins. The application assumes the companion deserializer (DS92LV0412) therefore the configuration pins are also both tied Low. The interface to the host is with 1.8 V LVCMOS levels, thus the VDDIO pin is connected

also to the 1.8V rail. The Optional Serial Bus Control is not used in this example, thus the SCL, SDA and ID[x] pins are left open. A delay cap is placed on the PDB signal to delay the enabling of the device until power is stable. Bypass capacitors are placed near the power supply pins. Ferrite beads are placed on the power lines for effective noise suppression.

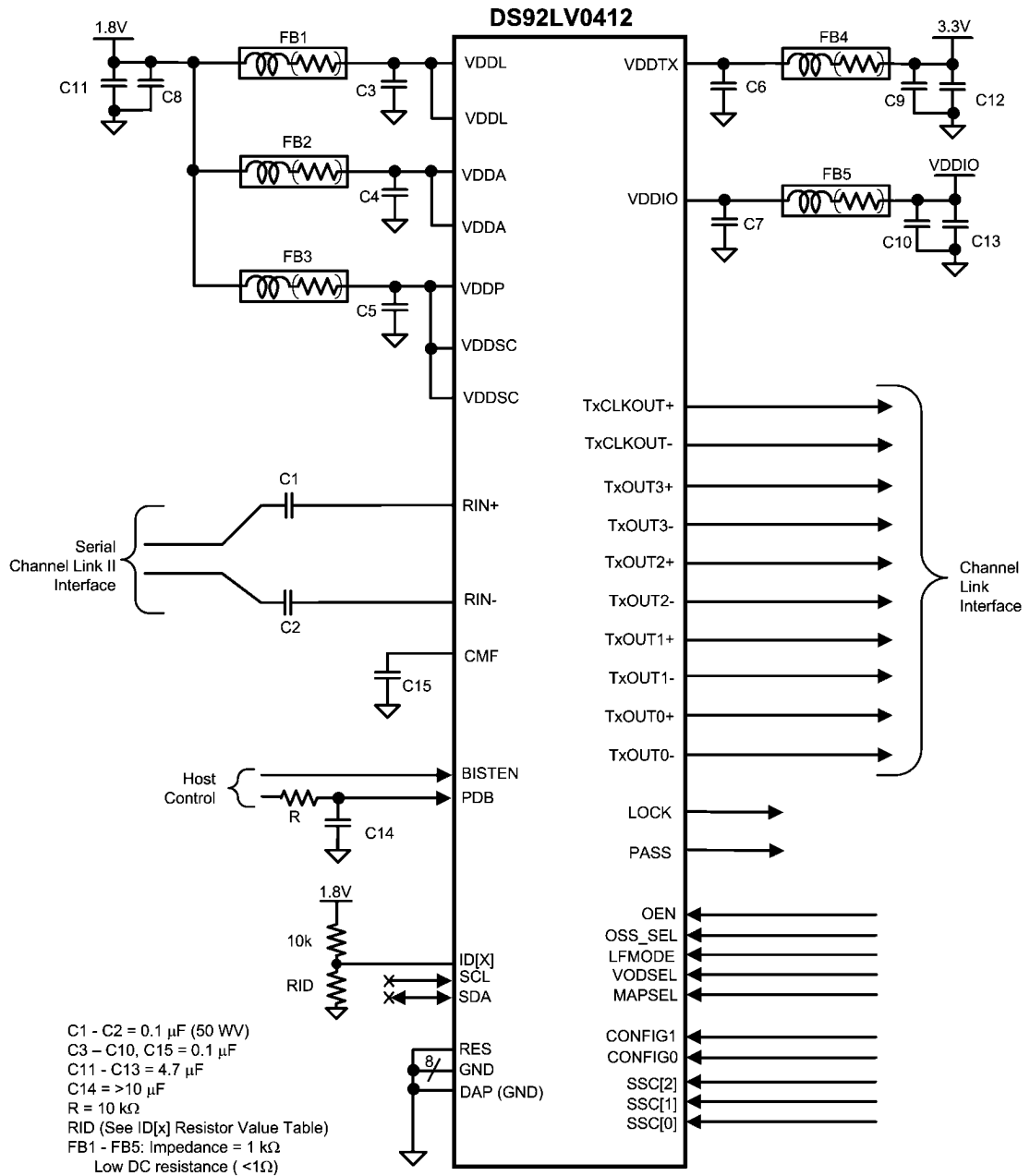

30125274

FIGURE 32. DS92LV0412 Typical Connection Diagram

Power Up Requirements and PDB Pin

The VDD (V_{DDn} and V_{DDIO}) supply ramp should be faster than 1.5 ms with a monotonic rise. If slower than 1.5 ms then a capacitor on the PDB pin is needed to ensure PDB arrives after all the VDD have settled to the recommended operating voltage. When PDB pin is pulled to V_{DDIO} , it is recommended to use a 10 kΩ pull-up and a 22 uF cap to GND to delay the PDB input signal.

Transmission Media

The DS92LV0411 and the companion deserializer chipset is intended to be used in a point-to-point configuration, through a PCB trace, or through twisted pair cable. The DS92LV0411 provide internal terminations providing a clean signaling environment. The interconnect for LVDS should present a differential impedance of 100 Ohms. Use cables and connectors that have matched differential impedance to minimize impedance discontinuities. Shielded or un-shielded cables

may be used depending upon the noise environment and application requirements.

Live Link Insertion

The serializer and deserializer devices support live link or cable hot plug applications. The automatic receiver lock to random data “plug & go” hot insertion capability allows the DS92LV0412 to attain lock to the active data stream during a live cable insertion event.

Alternate Color / Data Mapping

Color Mapped data Pin names are provided to specify a recommended mapping for 24-bit and 18-bit Applications. When connecting to earlier generations of Channel Link II deserializer devices, a color mapping review is recommended to ensure the correct connectivity is obtained. [Table 14](#) provides examples for interfacing between DS92LV0411 and different deserializers.

TABLE 14. Serializer Alternate Color / Data Mapping

Channel Link	Bit Number	RGB (LSB Example)	DS92LV2412	DS90UR124	DS99R124Q	DS90C124	
RxIN3	Bit 26	B1	B1	N/A			
	Bit 25	B0	B0				
	Bit 24	G1	G1				
	Bit 23	G0	G0				
	Bit 22	R1	R1				
	Bit 21	R0	R0				
RxIN2	Bit 20	DE	DE	ROUT20	TxOUT2	ROUT20	
	Bit 19	VS	VS	ROUT19		ROUT19	
	Bit 18	HS	HS	ROUT18		ROUT18	
	Bit 17	B7	B7	ROUT17		ROUT17	
	Bit 16	B6	B6	B6ROUT10		ROUT16	ROUT16
	Bit 15	B5	B5	ROUT15		ROUT15	
	Bit 14	B4	B4	ROUT14		ROUT14	
RxIN1	Bit 13	B3	B3	ROUT13	TxOUT1	ROUT13	
	Bit 12	B2	B2	ROUT12		ROUT12	
	Bit 11	G7	G7	ROUT11		ROUT11	
	Bit 10	G6	G6	ROUT10		ROUT10	
	Bit 9	G5	G5	ROUT9		ROUT9	
	Bit 8	G4	G4	ROUT8		ROUT8	
	Bit 7	G3	G3	ROUT7		ROUT7	
RxIN0	Bit 6	G2	G2	ROUT6	TxOUT0	ROUT6	
	Bit 5	R7	R7	ROUT5		ROUT5	
	Bit 4	R6	R6	ROUT4		ROUT4	
	Bit 3	R5	R5	ROUT3		ROUT3	
	Bit 2	R4	R4	ROUT2		ROUT2	
	Bit 1	R3	R3	ROUT1		ROUT1	
	Bit 0	R2	R2	ROUT0		ROUT0	
N/A			N/A	ROUT23	OS2	ROUT23	
				ROUT22	OS1	ROUT22	
				ROUT21	OS0	ROUT21	
DS92LV0411 Settings	MAPSEL = 0		CONFIG [1:0] = 00	CONFIG [1:0] = 10		CONFIG [1:0] = 11	

TABLE 15. Deserializer Alternate Color / Data Mapping

Channel Link	Bit Number	RGB (LSB Example)	DS92LV2411	DS90UR241	DS99R421Q	DS90C241
TxOUT3	Bit 26	B1	B1	N/A		
	Bit 25	B0	B0	N/A		
	Bit 24	G1	G1	N/A		
	Bit 23	G0	G0	N/A		
	Bit 22	R1	R1	N/A		
TxOUT2	Bit 21	R0	R0	N/A		
	Bit 20	DE	DE	DIN20	RxIN2	DIN20
	Bit 19	VS	VS	DIN19		DIN19
	Bit 18	HS	HS	DIN18		DIN18
	Bit 17	B7	B7	DIN17		DIN17
	Bit 16	B6	B6ROUT10	DIN16		DIN16
	Bit 15	B5	B5	DIN15		DIN15
Bit 14	B4	B4	DIN14	DIN14		
TxOUT1	Bit 13	B3	B3	DIN13	RxIN1	DIN13
	Bit 12	B2	B2	DIN12		DIN12
	Bit 11	G7	G7	DIN11		DIN11
	Bit 10	G6	G6	DIN10		DIN10
	Bit 9	G5	G5	DIN9		DIN9
	Bit 8	G4	G4	DIN8		DIN8
	Bit 7	G3	G3	DIN7		DIN7
TxOUT0	Bit 6	G2	G2	DIN6	RxIN0	DIN6
	Bit 5	R7	R7	DIN5		DIN5
	Bit 4	R6	R6	DIN4		DIN4
	Bit 3	R5	R5	DIN3		DIN3
	Bit 2	R4	R4	DIN2		DIN2
	Bit 1	R3	R3	DIN1		DIN1
	Bit 0	R2	R2	DIN0		DIN0
N/A			N/A	DIN923	OS2	DIN923
				DIN922	OS1	DIN922
				DIN921	OS0	DIN921
DS92LV0412 Settings	MAPSEL = 0		CONFIG [1:0] = 00	CONFIG [1:0] = 10		CONFIG [1:0] = 11

PCB LAYOUT AND POWER SYSTEM CONSIDERATIONS

Circuit board layout and stack-up for the LVDS devices should be designed to provide low-noise power feed to the device. Good layout practice will also separate high frequency or high-level inputs and outputs to minimize unwanted stray noise pickup, feedback and interference. Power system performance may be greatly improved by using thin dielectrics (2 to 4 mils) for power / ground sandwiches. This arrangement provides plane capacitance for the PCB power system with low-inductance parasitics, which has proven especially effective at high frequencies, and makes the value and placement of external bypass capacitors less critical. External bypass capacitors should include both RF ceramic and tantalum electrolytic types. RF capacitors may use values in the range of 0.01 uF to 0.1 uF. Tantalum capacitors may be in the 2.2 uF to 10 uF range. Voltage rating of the tantalum capacitors should be at least 5X the power supply voltage being used.

Surface mount capacitors are recommended due to their smaller parasitics. When using multiple capacitors per supply pin, locate the smaller value closer to the pin. A large bulk

capacitor is recommend at the point of power entry. This is typically in the 50uF to 100uF range and will smooth low frequency switching noise. It is recommended to connect power and ground pins directly to the power and ground planes with bypass capacitors connected to the plane with via on both ends of the capacitor. Connecting power or ground pins to an external bypass capacitor will increase the inductance of the path.

A small body size X7R chip capacitor, such as 0603, is recommended for external bypass. Its small body size reduces the parasitic inductance of the capacitor. The user must pay attention to the resonance frequency of these external bypass capacitors, usually in the range of 20-30 MHz. To provide effective bypassing, multiple capacitors are often used to achieve low impedance between the supply rails over the frequency of interest. At high frequency, it is also a common practice to use two vias from power and ground pins to the planes, reducing the impedance at high frequency.

Some devices provide separate power and ground pins for different portions of the circuit. This is done to isolate switch-

ing noise effects between different sections of the circuit. Separate planes on the PCB are typically not required. Pin Description tables typically provide guidance on which circuit blocks are connected to which power pin pairs. In some cases, an external filter may be used to provide clean power to sensitive circuits such as PLLs.

Use at least a four layer board with a power and ground plane. Locate LVCMOS signals away from the LVDS lines to prevent coupling from the LVCMOS lines to the LVDS lines. Closely-coupled differential lines of 100 Ohms are typically recommended for LVDS interconnect. The closely coupled lines help to ensure that coupled noise will appear as common-mode and thus is rejected by the receivers. The tightly coupled lines will also radiate less.

Information on the LLP style package is provided in National Application Note: AN-1187.

LVDS INTERCONNECT GUIDELINES

See AN-1108 and AN-905 for full details.

- Use 100Ω coupled differential pairs
- Use the S/2S/3S rule in spacings
 - S = space between the pair
 - 2S = space between pairs
 - 3S = space to LVCMOS signal
- Minimize the number of Vias
- Use differential connectors when operating above 500Mbps line speed
- Maintain balance of the traces
- Minimize skew within the pair
- Terminate as close to the TX outputs and RX inputs as possible

Additional general guidance can be found in the LVDS Owner's Manual - available in PDF format from the National web site at: www.national.com/lvds

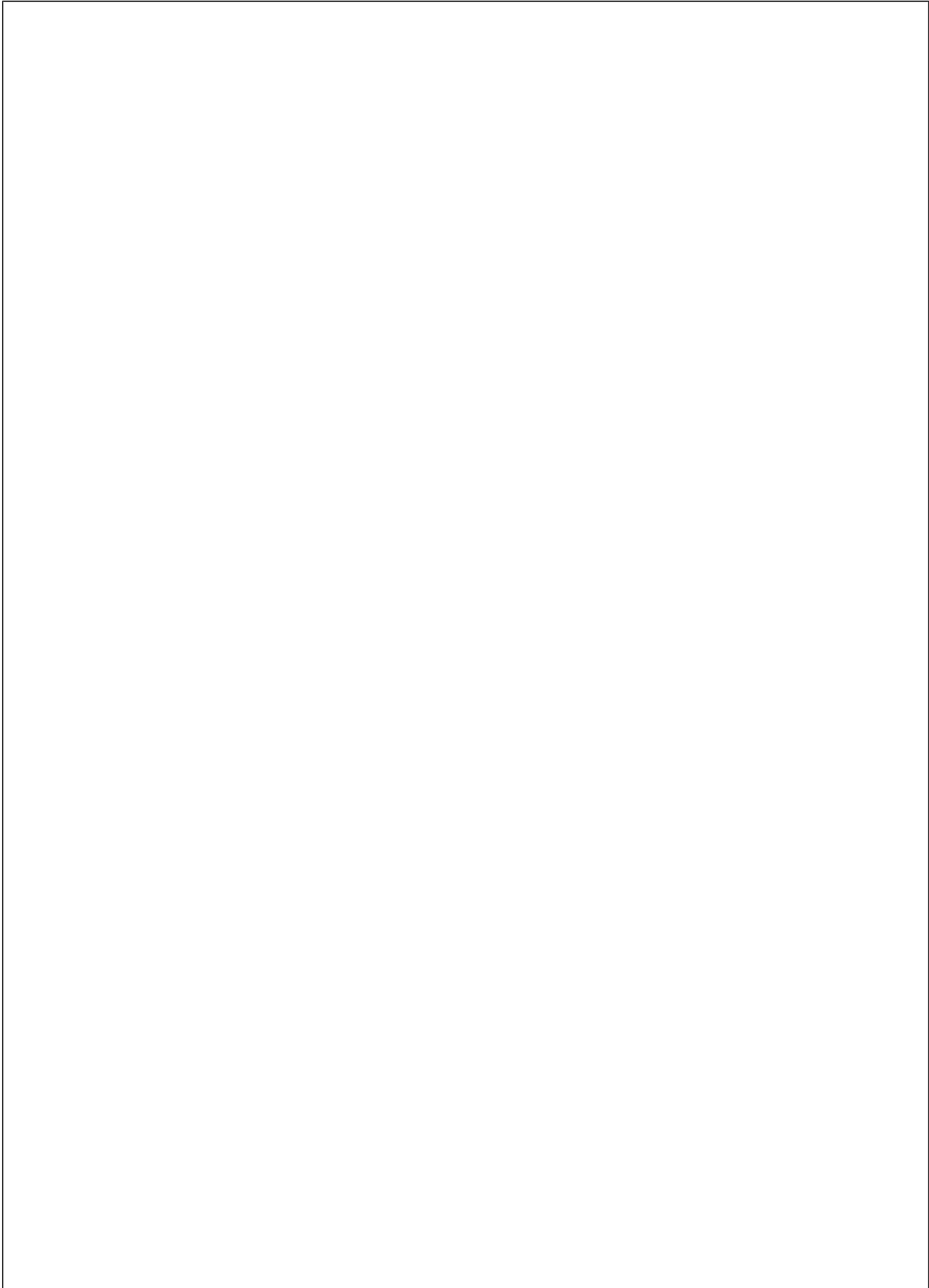

Physical Dimensions inches (millimeters) unless otherwise noted

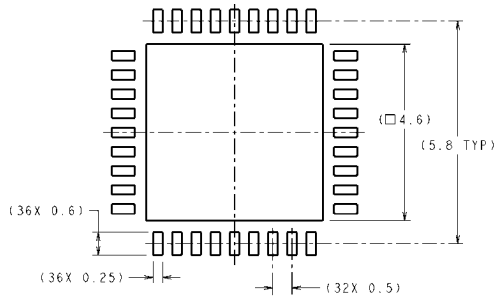

RECOMMENDED LAND PATTERN

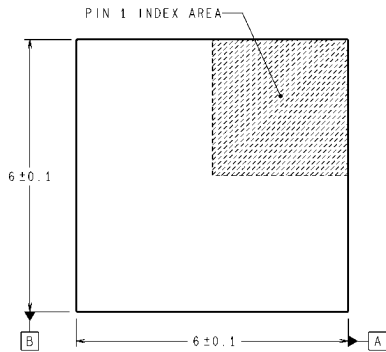

DIMENSIONS ARE IN MILLIMETERS
DIMENSIONS IN () FOR REFERENCE ONLY

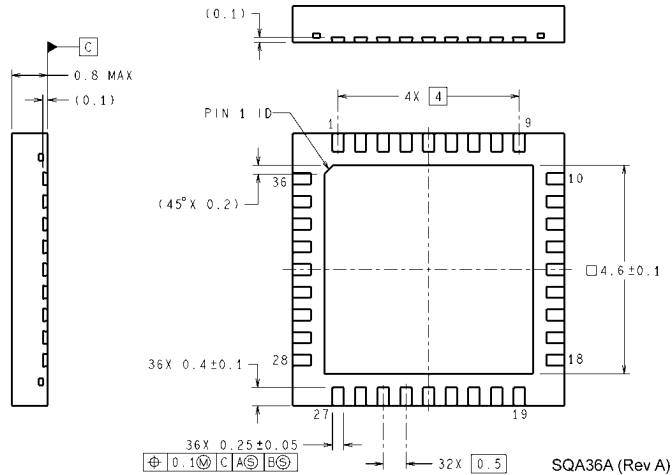

**36-pin LLP Package (6.0 mm X 6.0 mm X 0.8 mm, 0.5 mm pitch)
NS Package Number SQA36A**

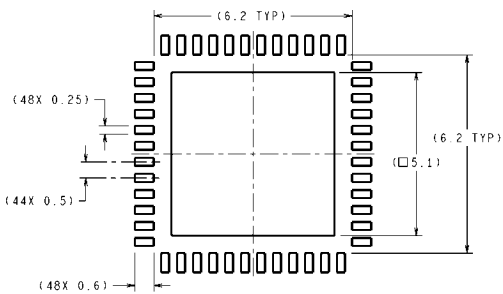

RECOMMENDED LAND PATTERN

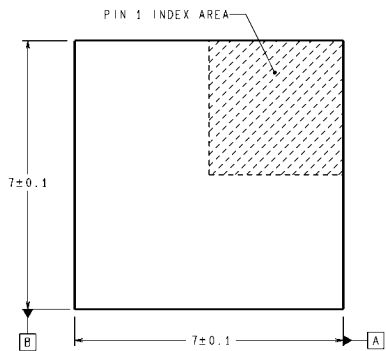

DIMENSIONS ARE IN MILLIMETERS
DIMENSIONS IN () FOR REFERENCE ONLY

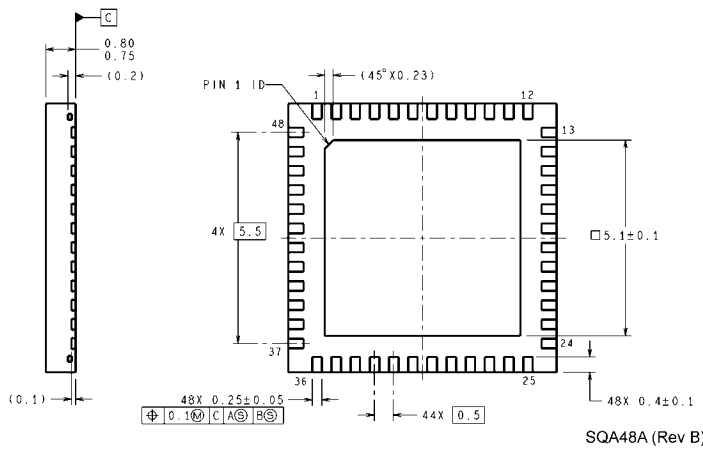

DS92LV0412 48-pin LLP Package (7.0 mm X 7.0 mm X 0.8 mm, 0.5 mm pitch) NS Package Number SQA48A

Notes

For more National Semiconductor product information and proven design tools, visit the following Web sites at:
www.national.com

Products		Design Support	
Amplifiers	www.national.com/amplifiers	WEBENCH® Tools	www.national.com/webench
Audio	www.national.com/audio	App Notes	www.national.com/appnotes
Clock and Timing	www.national.com/timing	Reference Designs	www.national.com/refdesigns
Data Converters	www.national.com/adc	Samples	www.national.com/samples
Interface	www.national.com/interface	Eval Boards	www.national.com/evalboards
LVDS	www.national.com/lvds	Packaging	www.national.com/packaging
Power Management	www.national.com/power	Green Compliance	www.national.com/quality/green
Switching Regulators	www.national.com/switchers	Distributors	www.national.com/contacts
LDOs	www.national.com/ldo	Quality and Reliability	www.national.com/quality
LED Lighting	www.national.com/led	Feedback/Support	www.national.com/feedback
Voltage References	www.national.com/vref	Design Made Easy	www.national.com/easy
PowerWise® Solutions	www.national.com/powerwise	Applications & Markets	www.national.com/solutions
Serial Digital Interface (SDI)	www.national.com/sdi	Mil/Aero	www.national.com/milaero
Temperature Sensors	www.national.com/tempensors	SolarMagic™	www.national.com/solarmagic
PLL/VCO	www.national.com/wireless	PowerWise® Design University	www.national.com/training

THE CONTENTS OF THIS DOCUMENT ARE PROVIDED IN CONNECTION WITH NATIONAL SEMICONDUCTOR CORPORATION ("NATIONAL") PRODUCTS. NATIONAL MAKES NO REPRESENTATIONS OR WARRANTIES WITH RESPECT TO THE ACCURACY OR COMPLETENESS OF THE CONTENTS OF THIS PUBLICATION AND RESERVES THE RIGHT TO MAKE CHANGES TO SPECIFICATIONS AND PRODUCT DESCRIPTIONS AT ANY TIME WITHOUT NOTICE. NO LICENSE, WHETHER EXPRESS, IMPLIED, ARISING BY ESTOPPEL OR OTHERWISE, TO ANY INTELLECTUAL PROPERTY RIGHTS IS GRANTED BY THIS DOCUMENT.

TESTING AND OTHER QUALITY CONTROLS ARE USED TO THE EXTENT NATIONAL DEEMS NECESSARY TO SUPPORT NATIONAL'S PRODUCT WARRANTY. EXCEPT WHERE MANDATED BY GOVERNMENT REQUIREMENTS, TESTING OF ALL PARAMETERS OF EACH PRODUCT IS NOT NECESSARILY PERFORMED. NATIONAL ASSUMES NO LIABILITY FOR APPLICATIONS ASSISTANCE OR BUYER PRODUCT DESIGN. BUYERS ARE RESPONSIBLE FOR THEIR PRODUCTS AND APPLICATIONS USING NATIONAL COMPONENTS. PRIOR TO USING OR DISTRIBUTING ANY PRODUCTS THAT INCLUDE NATIONAL COMPONENTS, BUYERS SHOULD PROVIDE ADEQUATE DESIGN, TESTING AND OPERATING SAFEGUARDS.

EXCEPT AS PROVIDED IN NATIONAL'S TERMS AND CONDITIONS OF SALE FOR SUCH PRODUCTS, NATIONAL ASSUMES NO LIABILITY WHATSOEVER, AND NATIONAL DISCLAIMS ANY EXPRESS OR IMPLIED WARRANTY RELATING TO THE SALE AND/OR USE OF NATIONAL PRODUCTS INCLUDING LIABILITY OR WARRANTIES RELATING TO FITNESS FOR A PARTICULAR PURPOSE, MERCHANTABILITY, OR INFRINGEMENT OF ANY PATENT, COPYRIGHT OR OTHER INTELLECTUAL PROPERTY RIGHT.

LIFE SUPPORT POLICY

NATIONAL'S PRODUCTS ARE NOT AUTHORIZED FOR USE AS CRITICAL COMPONENTS IN LIFE SUPPORT DEVICES OR SYSTEMS WITHOUT THE EXPRESS PRIOR WRITTEN APPROVAL OF THE CHIEF EXECUTIVE OFFICER AND GENERAL COUNSEL OF NATIONAL SEMICONDUCTOR CORPORATION. As used herein:

Life support devices or systems are devices which (a) are intended for surgical implant into the body, or (b) support or sustain life and whose failure to perform when properly used in accordance with instructions for use provided in the labeling can be reasonably expected to result in a significant injury to the user. A critical component is any component in a life support device or system whose failure to perform can be reasonably expected to cause the failure of the life support device or system or to affect its safety or effectiveness.

National Semiconductor and the National Semiconductor logo are registered trademarks of National Semiconductor Corporation. All other brand or product names may be trademarks or registered trademarks of their respective holders.

Copyright© 2010 National Semiconductor Corporation

For the most current product information visit us at www.national.com



National Semiconductor Americas Technical Support Center
 Email: support@nsc.com
 Tel: 1-800-272-9959

National Semiconductor Europe Technical Support Center
 Email: europe.support@nsc.com

National Semiconductor Asia Pacific Technical Support Center
 Email: ap.support@nsc.com

National Semiconductor Japan Technical Support Center
 Email: jpn.feedback@nsc.com