

Field Network Modules 60-UNIT Series

ANALOG I/O MODULE

(Modbus; RS-485)

Functions & Features

- Interfacing analog I/O signals from/to 10-RACK or 18-RACK modules with Modbus
- Saving power and I/O wiring inside an instrumentation panel

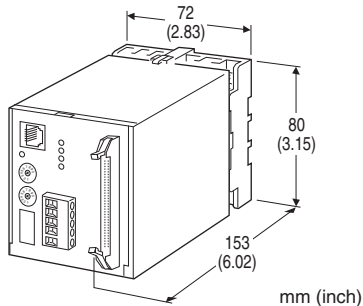

MODEL: 60M-16[1]-[2][3]

ORDERING INFORMATION

- Code number: 60M-16[1]-[2][3]
- Specify a code from below for each [1] through [3].
(e.g. 60M-161-K/Q)
- Specify the specification for option code /Q
(e.g. /C01/S01)

NO. OF CHANNELS

16: 16 points

[1] I/O TYPE

- 1: Input
- 2: Output

[2] POWER INPUT

AC Power

K: 85 - 132 V AC
(Operational voltage range 85 - 132 V, 47 - 66 Hz)

DC Power

R: 24 V DC
(Operational voltage range 24 V \pm 10 %, ripple 10 %p-p max.)

[3] OPTIONS

blank: none

/Q: With options (specify the specification)

SPECIFICATIONS OF OPTION: Q (multiple selections)

COATING (For the detail, refer to M-System's web site.)

- /C01: Silicone coating
- /C02: Polyurethane coating
- /C03: Rubber coating

TERMINAL SCREW MATERIAL

- /S01: Stainless steel

RELATED PRODUCTS

- Special cable (model: MCN34)

PACKAGE INCLUDES...

- Terminating resistor (110 Ω , 0.25 W)

GENERAL SPECIFICATIONS

Construction: Plug-in

Connection

Modbus: Euro type connector terminal (applicable wire size: 0.2 to 2.5 mm², stripped length 7 mm)

I/O: 34-pin connector (OMRON XG4A-3434)

Power input: M3.5 screw terminal

Screw terminal: Chromated steel (standard) or stainless steel

Housing material: Flame-resistant resin (black)

Isolation: I/O to Modbus to power to FG1

Power indicator: Green LED turns on with power supplied.

MODBUS COMMUNICATION

Communication: Conforms to TIA/EIA-485-A

Transmission setting: DIP switch

Data: RTU (Binary) or ASCII

Parity: none, even or odd

Baud rate: 4800, 9600, 19.2 k, 38.4 k (bps)

Node address setting: Rotary switch; 01 - F7
(factory setting: 00)

L RUN indicator: Red LED turns on for 10 sec. when the module receives data.

L ERR. indicator: Red LED turns on at errors in parity, framing, overrun, CRC or LRC.

SD indicator: Red LED turns on when transmitting.

RD indicator: Red LED turns on when receiving.

Analog input: Programming Unit (model: PU-2x) or via Modbus

Moving averaging: None, every 2 or 4 samples

Sampling rate: 400, 240, or 160 (msec.)

INPUT SPECIFICATIONS

■ Analog Input

Input range: 1 - 5 V DC

Input resistance: $\geq 1 \text{ M}\Omega$

10-RACK and 18-RACK I/O modules must be isolated types. Non-isolated modules such as 10BW and 18BW are not usable.

■ A/D Conversion Output

• Signed binary (2-byte data)

Signal range 0 - 100 % is proportional to hexadecimal 0000 - 2710 (0 - 10000). -15 to 0 % is a negative range represented by 2's complements.

Overall range is represented by hexadecimal FA24 - 2CEC (-1500 - +11500), for -15 - +115 %.

• Floating data (4-byte data)

Initial signal range 0 - 100 % is proportional to 0 - 10000, that is possible to be scaled into a specific range.

• Input Connector Pin Assignment

PIN NO.	ASSIGNMENT	PIN NO.	ASSIGNMENT
1	Input 1	2	COM
3	Input 2	4	COM
5	Input 3	6	COM
7	Input 4	8	COM
9	Input 5	10	COM
11	Input 6	12	COM
13	Input 7	14	COM
15	Input 8	16	COM
17	Input 9	18	COM
19	Input 10	20	COM
21	Input 11	22	COM
23	Input 12	24	COM
25	Input 13	26	COM
27	Input 14	28	COM
29	Input 15	30	COM
31	Input 16	32	COM
33	No connection	34	No connection

OUTPUT SPECIFICATIONS

■ Analog Output

Output must be isolated with signal conditioners. When the transmission line is open, the last value sampled before failure is held.

Output range: 1 - 5 V DC

Load resistance: 20 k Ω minimum

10-RACK and 18-RACK I/O modules must be isolated types. Non-isolated modules such as 10BW and 18BW are not usable.

■ D/A Conversion Input

• Signed binary (2-byte data)

Signal range 0 - 100 % is proportional to hexadecimal 0000 - 2710 (0 - 10000). -15 to 0 % is a negative range represented by 2's complements.

Overall range is represented by hexadecimal FA24 - 2CEC (-1500 - +11500), for -15 - +115 %.

• Floating data (4-byte data)

Initial signal range 0 - 100 % is proportional to 0 - 10000, that is possible to be scaled into a specific range.

• Output Connector Pin Assignment

PIN NO.	ASSIGNMENT	PIN NO.	ASSIGNMENT
1	Output 1	2	COM
3	Output 2	4	COM
5	Output 3	6	COM
7	Output 4	8	COM
9	Output 5	10	COM
11	Output 6	12	COM
13	Output 7	14	COM
15	Output 8	16	COM
17	Output 9	18	COM
19	Output 10	20	COM
21	Output 11	22	COM
23	Output 12	24	COM
25	Output 13	26	COM
27	Output 14	28	COM
29	Output 15	30	COM
31	Output 16	32	COM
33	No connection	34	No connection

INSTALLATION

Power consumption

•AC: Approx. 4 VA

•DC: Approx. 4 W (160 mA)

Operating temperature: -5 to +55°C (23 to 131°F)

Operating humidity: 30 to 90 %RH (non-condensing)

Atmosphere: No corrosive gas or heavy dust

Mounting: Surface or DIN rail

Weight: 450 g (0.99 lb)

PERFORMANCE in percentage of span

A/D conversion: $\pm 0.1 \%$

D/A conversion: $\pm 0.1 \%$

Temp. coefficient: $\pm 0.015 \%/^{\circ}\text{C}$ ($\pm 0.008 \%/^{\circ}\text{F}$)

Permissible power failure duration: $\leq 10 \text{ msec.}$

Insulation resistance: $\geq 100 \text{ M}\Omega$ with 500 V DC

Dielectric strength: 1500 V AC @ 1 minute (input or output to Modbus to power)

2000 V AC @ 1 minute (input or output or Modbus or power to FG1)

EXTERNAL VIEW

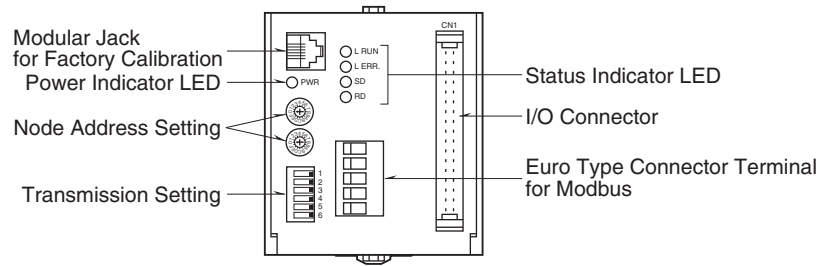

MODBUS FUNCTION CODES & SUPPORTED CODES

■ Data and Control Functions

CODE	NAME		
01	Read Coil Status	X	Digital output from the slave
02	Read Input Status	X	Status of digital inputs to the slave
03	Read Holding Registers	X	General purpose register within the slave
04	Read Input Registers	X	Collected data from the field by the slave
05	Force Single Coil	X	Digital output from the slave
06	Preset Single Registers	X	General purpose register within the slave
07	Read Exception Status		
08	Diagnostics	X	
09	Program 484		
10	Poll 484		
11	Fetch Comm. Event Counter		Fetch a status word and an event counter
12	Fetch Comm. Event Log		A status word, an event counter, a message count and a field of event bytes
13	Program Controller		
14	Poll Controller		
15	Force Multiple Coils	X	Digital output from the slave
16	Preset Multiple Registers	X	General purpose register within the slave
17	Report Slave ID		Slave type / 'RUN' status
18	Program 884 / M84		
19	Reset Comm. Link		
20	Read General Reference		
21	Write General Reference		
22	Mask Write 4X Register		
23	Read/Write 4X Registers		
24	Read FIFO Queue		

■ Exception Codes

CODE	NAME		
01	Illegal Function	X	Function code is not allowable for the slave
02	Illegal Data Address	X	Address is not available within the slave
03	Illegal Data Value	X	Data is not valid for the function
04	Slave Device Failure		
05	Acknowledge		
06	Slave Device Busy		
07	Negative Acknowledge		
08	Memory Parity Error		

Diagnostic Subfunctions

CODE	NAME		
00	Return Query Data	X	Loop back test
01	Restart Comm. Option	X	Reset the slave and clear all counters
02	Return Diagnostic Register	X	Contents of the diagnostic data (2 bytes)
03	Change ASCII Input Delimiter	X	Delimiter character of ASCII message
04	Force Listen Only Mode	X	Force the slave into Listen Only Mode

MODBUS I/O ASSIGNMENT

	ADDRESS	TYPE		DATA TYPE	DATA
		1	2		
Coil (0X)	1 – 16	X			Averaging SW *
	17 – 32	X			Sampling rate SW **
Inputs (1X)	1 – 16	X	X		Analog channel status (active channel)
	17 – 32	X	X		Analog status (out of range)
Input Registers (3X)	1 – 16	X		I	Analog input
	17 – 48	X		F	Analog input
Holding Registers (4X)	1 – 16		X	I	Analog output
	17 – 48		X	F	Analog output
	49 – 80	X	X	F	Full scale
	81 – 112	X	X	F	Zero scale

Type

- 1 : Analog input
- 2 : Analog output

Data Type

- F : Floating
- I : Int 0 – 10000 (0 – 100%)

*Averaging SW

- 1 : 4 samples
- 2 : 2 samples
- 3 : None

**Sampling rate SW

- 17 : 400 millisecc.
- 18 : 240 millisecc.
- 19 : 160 millisecc.

EXTERNAL DIMENSIONS & TERMINAL ASSIGNMENTS unit: mm (inch)

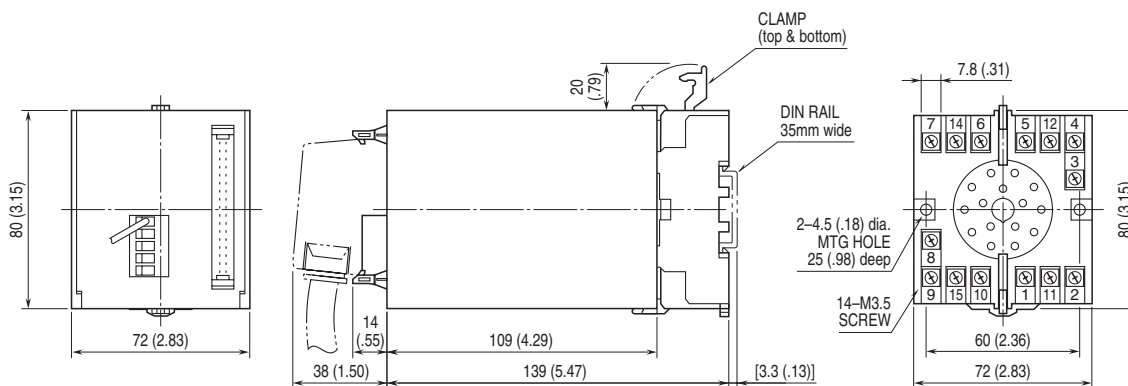

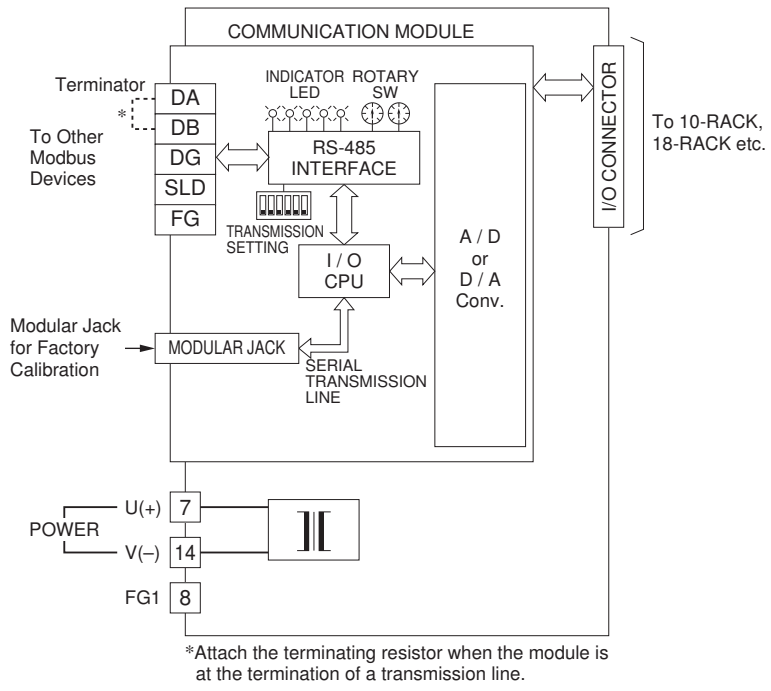

•When mounting, no extra space is needed between units.

SCHEMATIC CIRCUITRY & CONNECTION DIAGRAM

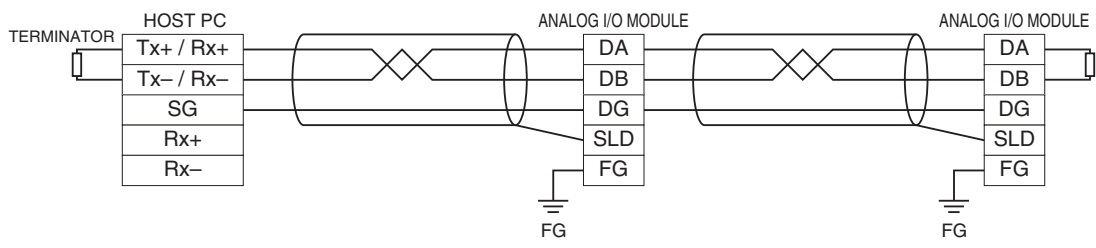

COMMUNICATION CABLE CONNECTIONS



 Specifications are subject to change without notice.