

100-Pin TQFP  
Commercial Temp  
Industrial Temp

**256K x 36**  
**9Mb Sync Burst SRAM**

333 MHz–200 MHz  
2.5 V or 3.3 V  $V_{DD}$   
2.5 V or 3.3 V I/O

## Features

- Single Cycle Deselect (SCD) operation
- 2.5 V or 3.3 V +10%/–10% core power supply
- 2.5 V or 3.3 V I/O supply
- $\overline{LBO}$  pin for Linear or Interleaved Burst mode
- Internal input resistors on mode pins allow floating mode pins
- Default to Interleaved Pipeline mode
- Byte Write ( $\overline{BW}$ ) and/or Global Write ( $\overline{GW}$ ) operation
- Internal self-timed write cycle
- Automatic power-down for portable applications
- JEDEC-standard 100-lead TQFP package
- Pb-Free 100-lead TQFP package available

## Functional Description

### Applications

The GS88037BT is a 9,437,184-bit (8,388,608-bit for x32 version) high performance synchronous SRAM with a 2-bit burst address counter. Although of a type originally developed for Level 2 Cache applications supporting high performance CPUs, the device now finds application in synchronous SRAM applications, ranging from DSP main store to networking chip set support.

### Controls

Addresses, data I/Os, chip enables ( $\overline{E1}$ ,  $E2$ ,  $\overline{E3}$ ), address burst control inputs ( $\overline{ADSP}$ ,  $\overline{ADSC}$ ,  $\overline{ADV}$ ), and write control inputs ( $\overline{Bx}$ ,  $\overline{BW}$ ,  $\overline{GW}$ ) are synchronous and are controlled by a positive-edge-triggered clock input (CK). Output enable ( $\overline{G}$ ) and power down control (ZZ) are asynchronous inputs. Burst cycles can be initiated with either  $\overline{ADSP}$  or  $\overline{ADSC}$  inputs. In

Burst mode, subsequent burst addresses are generated internally and are controlled by  $\overline{ADV}$ . The burst address counter may be configured to count in either linear or interleave order with the Linear Burst Order ( $\overline{LBO}$ ) input. The Burst function need not be used. New addresses can be loaded on every cycle with no degradation of chip performance.

### SCD Pipelined Reads

The GS88037BT is a SCD (Single Cycle Deselect) pipelined synchronous SRAM. DCD (Dual Cycle Deselect) versions are also available. SCD SRAMs pipeline deselect commands one stage less than read commands. SCD RAMs begin turning off their outputs immediately after the deselect command has been captured in the input registers.

### Byte Write and Global Write

Byte write operation is performed by using Byte Write enable ( $\overline{BW}$ ) input combined with one or more individual byte write signals ( $\overline{Bx}$ ). In addition, Global Write ( $\overline{GW}$ ) is available for writing all bytes at one time, regardless of the Byte Write control inputs.

### Sleep Mode

Low power (Sleep mode) is attained through the assertion (High) of the ZZ signal, or by stopping the clock (CK). Memory data is retained during Sleep mode.

### Core and Interface Voltages

The GS88037BT operates on a 2.5 V or 3.3 V power supply. All input are 3.3 V and 2.5 V compatible. Separate output power ( $V_{DDQ}$ ) pins are used to decouple output noise from the internal circuits and are 3.3 V and 2.5 V compatible.

## Parameter Synopsis

|                                   |             | -333 | -300 | -250 | -200 | Unit |
|-----------------------------------|-------------|------|------|------|------|------|
| <b>Pipeline</b><br><b>3-1-1-1</b> | $t_{KQ}$    | 2.0  | 2.2  | 2.3  | 2.7  | ns   |
|                                   | $t_{Cycle}$ | 3.0  | 3.3  | 4.0  | 5.0  | ns   |
| <b>3.3 V</b>                      | Curr (x36)  | 435  | 395  | 330  | 270  | mA   |
| <b>2.5 V</b>                      | Curr (x36)  | 435  | 395  | 330  | 270  | mA   |

GS88037B 100-Pin TQFP Pinout

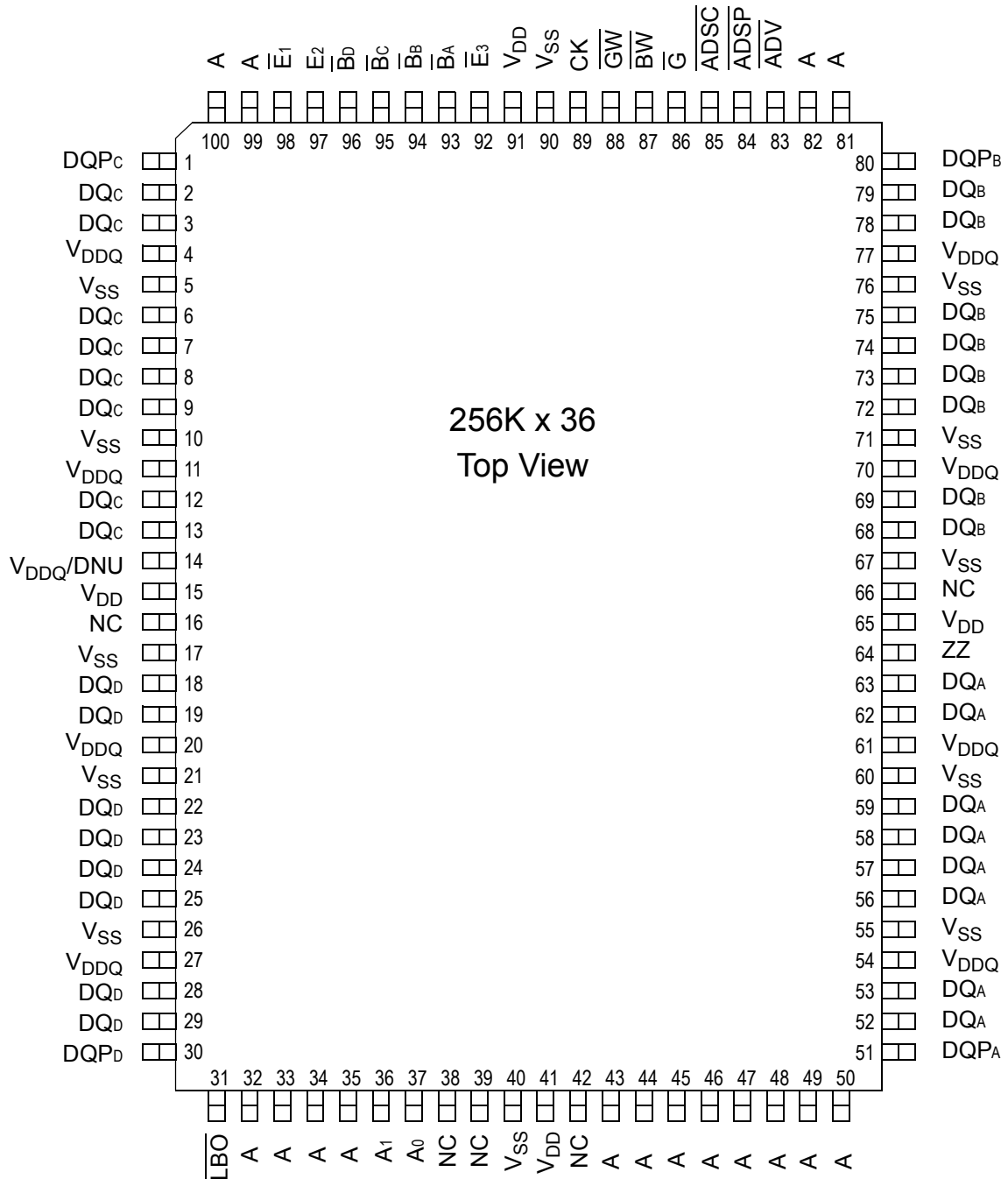

**TQFP Pin Description**

| <b>Symbol</b>  | <b>Type</b> | <b>Description</b>  |
|--|-------------|---|
| A <sub>0</sub> , A <sub>1</sub>  | I           | Address field LSBs and Address Counter preset Inputs  |
| A  | I           | Address Inputs  |
| DQ <sub>A</sub><br>DQ <sub>B</sub><br>DQ <sub>C</sub><br>DQ <sub>D</sub> | I/O         | Data Input and Output pins  |
| NC   | —           | No Connect  |
| $\overline{BW}$  | I           | Byte Write—Writes all enabled bytes; active low   |
| $\overline{B_A}$ , $\overline{B_B}$                                      | I           | Byte Write Enable for DQ <sub>A</sub> , DQ <sub>B</sub> Data I/Os; active low                       |
| $\overline{B_C}$ , $\overline{B_D}$                                      | I           | Byte Write Enable for DQ <sub>C</sub> , DQ <sub>D</sub> Data I/Os; active low                       |
| CK   | I           | Clock Input Signal; active high   |
| $\overline{GW}$  | I           | Global Write Enable—Writes all bytes; active low  |
| $\overline{E_1}$ , $\overline{E_3}$                                      | I           | Chip Enable; active low   |
| E <sub>2</sub>   | I           | Chip Enable; active high  |
| $\overline{G}$   | I           | Output Enable; active low   |
| $\overline{ADV}$   | I           | Burst address counter advance enable; active low  |
| $\overline{ADSP}$ , $\overline{ADSC}$                                    | I           | Address Strobe (Processor, Cache Controller); active low  |
| ZZ   | I           | Sleep Mode control; active high   |
| $\overline{LBO}$   | I           | Linear Burst Order mode; active low   |
| V <sub>DD</sub>  | I           | Core power supply   |
| V <sub>SS</sub>  | I           | I/O and Core Ground   |
| V <sub>DDQ</sub>   | I           | Output driver power supply  |
| V <sub>DDQ</sub> /DNU  | —           | V <sub>DDQ</sub> or V <sub>DD</sub> (must be tied high)<br>or<br>Do Not Use (must be left floating) |

GS88037B Block Diagram

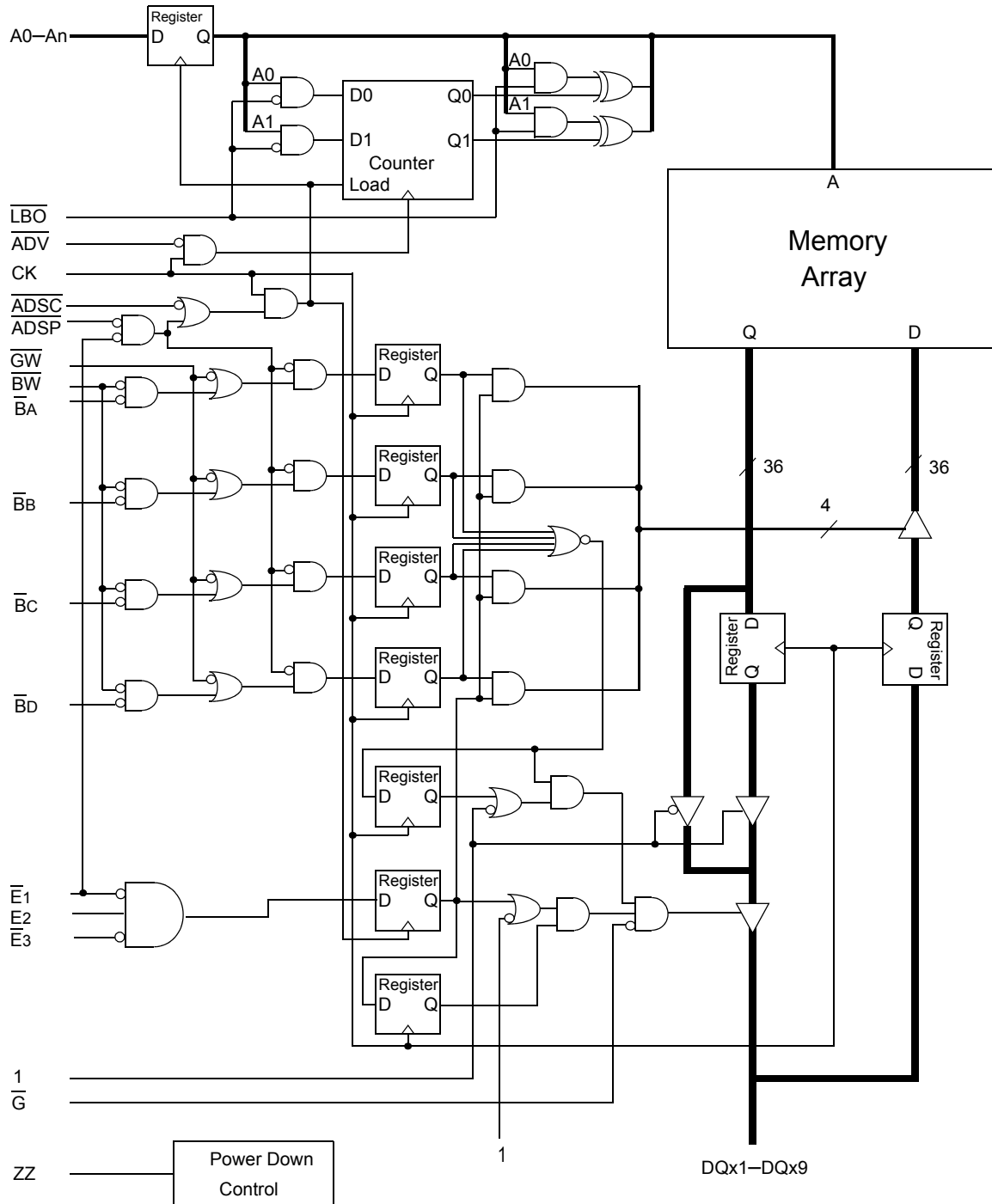

Note: Only x36 version shown for simplicity.

### Mode Pin Functions

| Mode Name           | Pin Name                | State   | Function                   |
|---------------------|-------------------------|---------|----------------------------|
| Burst Order Control | $\overline{\text{LBO}}$ | L       | Linear Burst               |
|                     |                         | H       | Interleaved Burst          |
| Power Down Control  | ZZ                      | L or NC | Active                     |
|                     |                         | H       | Standby, $I_{DD} = I_{SB}$ |

**Note:**

There is a pull-down device on the ZZ pin, so this input pin can be unconnected and the chip will operate in the default states as specified in the above tables.

### Burst Counter Sequences

#### Linear Burst Sequence

|             | A[1:0] | A[1:0] | A[1:0] | A[1:0] |
|-------------|--------|--------|--------|--------|
| 1st address | 00     | 01     | 10     | 11     |
| 2nd address | 01     | 10     | 11     | 00     |
| 3rd address | 10     | 11     | 00     | 01     |
| 4th address | 11     | 00     | 01     | 10     |

**Note:**

The burst counter wraps to initial state on the 5th clock.

#### Interleaved Burst Sequence

|             | A[1:0] | A[1:0] | A[1:0] | A[1:0] |
|-------------|--------|--------|--------|--------|
| 1st address | 00     | 01     | 10     | 11     |
| 2nd address | 01     | 00     | 11     | 10     |
| 3rd address | 10     | 11     | 00     | 01     |
| 4th address | 11     | 10     | 01     | 00     |

**Note:**

The burst counter wraps to initial state on the 5th clock.

**Byte Write Truth Table**

| Function        | $\overline{GW}$ | $\overline{BW}$ | $\overline{BA}$ | $\overline{BB}$ | $\overline{Bc}$ | $\overline{BD}$ | Notes   |
|-----------------|-----------------|-----------------|-----------------|-----------------|-----------------|-----------------|---------|
| Read            | H               | H               | X               | X               | X               | X               | 1       |
| Read            | H               | L               | H               | H               | H               | H               | 1       |
| Write byte a    | H               | L               | L               | H               | H               | H               | 2, 3    |
| Write byte b    | H               | L               | H               | L               | H               | H               | 2, 3    |
| Write byte c    | H               | L               | H               | H               | L               | H               | 2, 3, 4 |
| Write byte d    | H               | L               | H               | H               | H               | L               | 2, 3, 4 |
| Write all bytes | H               | L               | L               | L               | L               | L               | 2, 3, 4 |
| Write all bytes | L               | X               | X               | X               | X               | X               |         |

**Notes:**

1. All byte outputs are active in read cycles regardless of the state of Byte Write Enable inputs.
2. Byte Write Enable inputs  $\overline{BA}$ ,  $\overline{BB}$ ,  $\overline{BC}$  and/or  $\overline{BD}$  may be used in any combination with  $\overline{BW}$  to write single or multiple bytes.
3. All byte I/Os remain High-Z during all write operations regardless of the state of Byte Write Enable inputs.
4. Bytes "C" and "D" are only available on the x32 and x36 versions.

## Synchronous Truth Table

| Operation                          | Address Used    | State Diagram Key <sup>5</sup> | $\bar{E}_1$ | $E^2$    | $\overline{ADSP}$ | $\overline{ADSC}$ | $\overline{ADV}$ | $\bar{W}^3$ | DQ <sup>4</sup> |
|------------------------------------|-----------------|--------------------------------|-------------|----------|-------------------|-------------------|------------------|-------------|-----------------|
| <b>Deselect Cycle, Power Down</b>  | <b>None</b>     | <b>X</b>                       | <b>H</b>    | <b>X</b> | <b>X</b>          | <b>L</b>          | <b>X</b>         | <b>X</b>    | <b>High-Z</b>   |
| Deselect Cycle, Power Down         | None            | X                              | L           | F        | L                 | X                 | X                | X           | High-Z          |
| <b>Deselect Cycle, Power Down</b>  | <b>None</b>     | <b>X</b>                       | <b>L</b>    | <b>F</b> | <b>H</b>          | <b>L</b>          | <b>X</b>         | <b>X</b>    | <b>High-Z</b>   |
| Read Cycle, Begin Burst            | External        | R                              | L           | T        | L                 | X                 | X                | X           | Q               |
| <b>Read Cycle, Begin Burst</b>     | <b>External</b> | <b>R</b>                       | <b>L</b>    | <b>T</b> | <b>H</b>          | <b>L</b>          | <b>X</b>         | <b>F</b>    | <b>Q</b>        |
| <b>Write Cycle, Begin Burst</b>    | <b>External</b> | <b>W</b>                       | <b>L</b>    | <b>T</b> | <b>H</b>          | <b>L</b>          | <b>X</b>         | <b>T</b>    | <b>D</b>        |
| <i>Read Cycle, Continue Burst</i>  | <i>Next</i>     | <i>CR</i>                      | <i>X</i>    | <i>X</i> | <i>H</i>          | <i>H</i>          | <i>L</i>         | <i>F</i>    | <i>Q</i>        |
| Read Cycle, Continue Burst         | Next            | CR                             | H           | X        | X                 | H                 | L                | F           | Q               |
| <i>Write Cycle, Continue Burst</i> | <i>Next</i>     | <i>CW</i>                      | <i>X</i>    | <i>X</i> | <i>H</i>          | <i>H</i>          | <i>L</i>         | <i>T</i>    | <i>D</i>        |
| Write Cycle, Continue Burst        | Next            | CW                             | H           | X        | X                 | H                 | L                | T           | D               |
| Read Cycle, Suspend Burst          | Current         |                                | X           | X        | H                 | H                 | H                | F           | Q               |
| Read Cycle, Suspend Burst          | Current         |                                | H           | X        | X                 | H                 | H                | F           | Q               |
| Write Cycle, Suspend Burst         | Current         |                                | X           | X        | H                 | H                 | H                | T           | D               |
| Write Cycle, Suspend Burst         | Current         |                                | H           | X        | X                 | H                 | H                | T           | D               |

## Notes:

1. X = Don't Care, H = High, L = Low
2. E = T (True) if  $E_2 = 1$  and  $\bar{E}_3 = 0$ ; E = F (False) if  $E_2 = 0$  or  $\bar{E}_3 = 1$
3. W = T (True) and F (False) is defined in the Byte Write Truth Table preceding.
4.  $\bar{G}$  is an asynchronous input.  $\bar{G}$  can be driven high at any time to disable active output drivers.  $\bar{G}$  low can only enable active drivers (shown as "Q" in the Truth Table above).
5. All input combinations shown above are tested and supported. Input combinations shown in gray boxes need not be used to accomplish basic synchronous or synchronous burst operations and may be avoided for simplicity.
6. Tying  $\overline{ADSP}$  high and  $\overline{ADSC}$  low allows simple non-burst synchronous operations. See **BOLD** items above.
7. Tying  $\overline{ADSP}$  high and  $\overline{ADV}$  low while using  $\overline{ADSC}$  to load new addresses allows simple burst operations. See *ITALIC* items above.

Simplified State Diagram

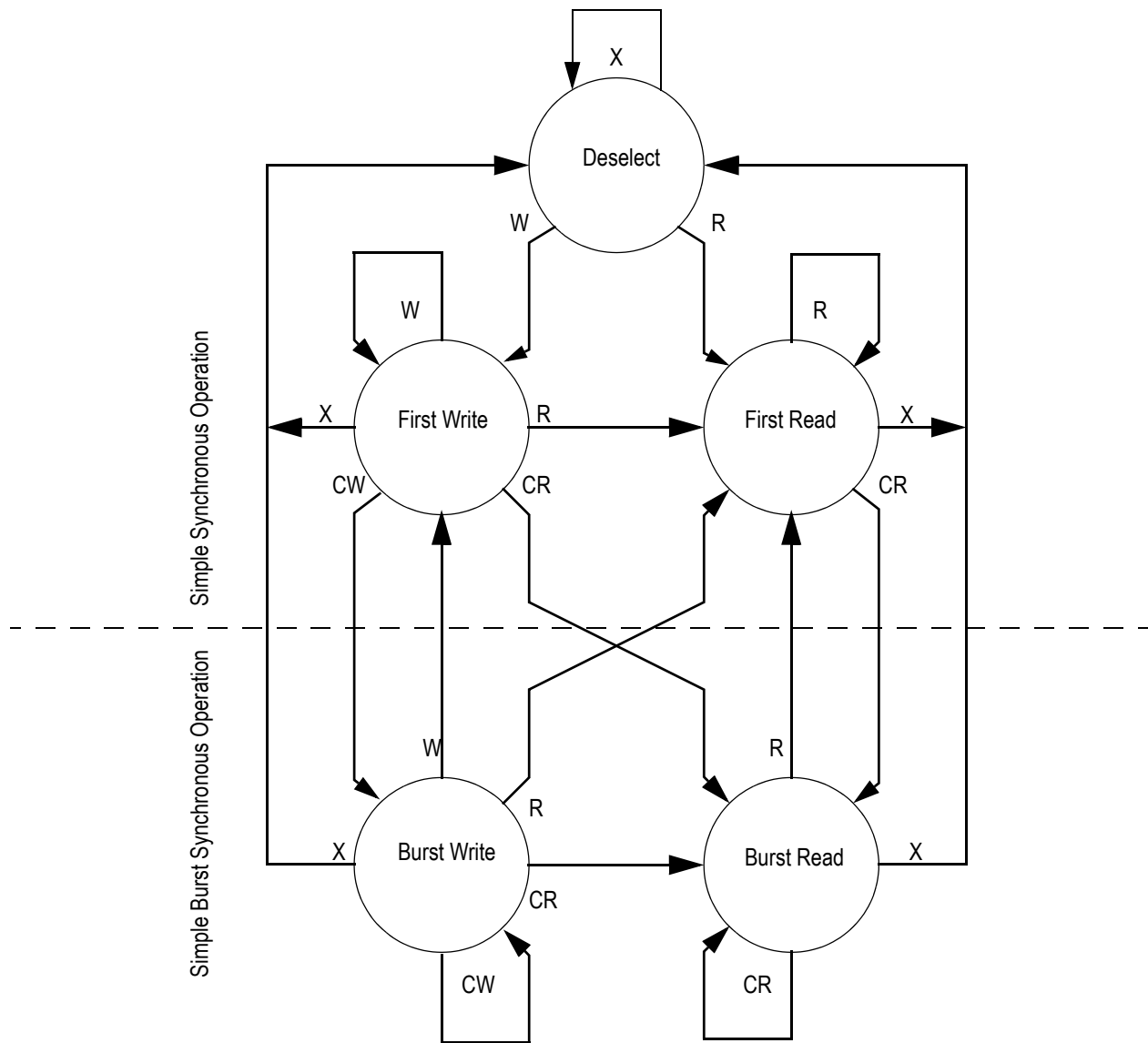

Notes:

1. The diagram shows only supported (tested) synchronous state transitions. The diagram presumes  $\overline{G}$  is tied low.
2. The upper portion of the diagram assumes active use of only the Enable ( $\overline{E1}$ ,  $E2$ , and  $E3$ ) and Write ( $\overline{BA}$ ,  $\overline{BB}$ ,  $\overline{BC}$ ,  $\overline{BD}$ ,  $\overline{BW}$ , and  $\overline{GW}$ ) control inputs, and that  $\overline{ADSP}$  is tied high and  $\overline{ADSC}$  is tied low.
3. The upper and lower portions of the diagram together assume active use of only the Enable, Write, and  $\overline{ADSC}$  control inputs, and assumes  $\overline{ADSP}$  is tied high and  $\overline{ADV}$  is tied low.

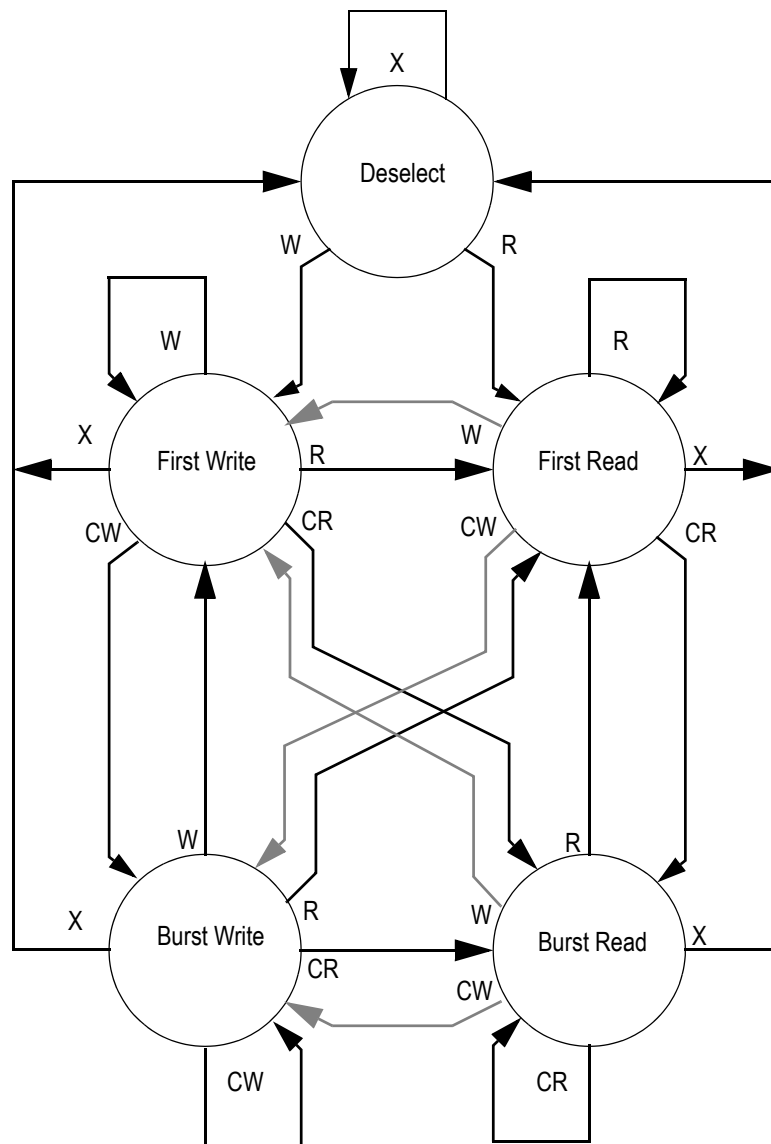

Simplified State Diagram with  $\bar{G}$ 

**Notes:**

1. The diagram shows supported (tested) synchronous state transitions plus supported transitions that depend upon the use of  $\bar{G}$ .
2. Use of "Dummy Reads" (Read Cycles with  $\bar{G}$  High) may be used to make the transition from Read cycles to Write cycles without passing through a Deselect cycle. Dummy Read cycles increment the address counter just like normal read cycles.
3. Transitions shown in gray tone assume  $\bar{G}$  has been pulsed high long enough to turn the RAM's drivers off and for incoming data to meet Data Input Set Up Time.

**Absolute Maximum Ratings**

 (All voltages reference to  $V_{SS}$ )

| Symbol     | Description                   | Value  | Unit |
|------------|-------------------------------|--|------|
| $V_{DD}$   | Voltage on $V_{DD}$ Pins      | -0.5 to 4.6                                  | V    |
| $V_{DDQ}$  | Voltage in $V_{DDQ}$ Pins     | -0.5 to 4.6                                  | V    |
| $V_{CK}$   | Voltage on Clock Input Pin    | -0.5 to 6                                    | V    |
| $V_{I/O}$  | Voltage on I/O Pins           | -0.5 to $V_{DDQ} + 0.5$ ( $\leq 4.6$ V max.) | V    |
| $V_{IN}$   | Voltage on Other Input Pins   | -0.5 to $V_{DD} + 0.5$ ( $\leq 4.6$ V max.)  | V    |
| $I_{IN}$   | Input Current on Any Pin      | +/-20  | mA   |
| $I_{OUT}$  | Output Current on Any I/O Pin | +/-20  | mA   |
| $P_D$      | Package Power Dissipation     | 1.5  | W    |
| $T_{STG}$  | Storage Temperature           | -55 to 125                                   | °C   |
| $T_{BIAS}$ | Temperature Under Bias        | -55 to 125                                   | °C   |

**Note:**

Permanent damage to the device may occur if the Absolute Maximum Ratings are exceeded. Operation should be restricted to Recommended Operating Conditions. Exposure to conditions exceeding the Absolute Maximum Ratings, for an extended period of time, may affect reliability of this component.

**Power Supply Voltage Ranges**

| Parameter                          | Symbol     | Min. | Typ. | Max. | Unit | Notes |
|------------------------------------|------------|------|------|------|------|-------|
| 3.3 V Supply Voltage               | $V_{DD3}$  | 3.0  | 3.3  | 3.6  | V    |       |
| 2.5 V Supply Voltage               | $V_{DD2}$  | 2.3  | 2.5  | 2.7  | V    |       |
| 3.3 V $V_{DDQ}$ I/O Supply Voltage | $V_{DDQ3}$ | 3.0  | 3.3  | 3.6  | V    |       |
| 2.5 V $V_{DDQ}$ I/O Supply Voltage | $V_{DDQ2}$ | 2.3  | 2.5  | 2.7  | V    |       |

**Notes:**

- The part numbers of Industrial Temperature Range versions end the character "I". Unless otherwise noted, all performance specifications quoted are evaluated for worst case in the temperature range marked on the device.
- Input Under/overshoot voltage must be  $-2\text{ V} > V_i < V_{DDn} + 2\text{ V}$  not to exceed 4.6 V maximum, with a pulse width not to exceed 20% tKC.

**V<sub>DDQ3</sub> Range Logic Levels**

| Parameter                               | Symbol           | Min. | Typ. | Max.                   | Unit | Notes |
|---|------------------|------|------|------------------------|------|-------|
| V <sub>DD</sub> Input High Voltage      | V <sub>IH</sub>  | 2.0  | —    | V <sub>DD</sub> + 0.3  | V    | 1     |
| V <sub>DD</sub> Input Low Voltage       | V <sub>IL</sub>  | -0.3 | —    | 0.8                    | V    | 1     |
| V <sub>DDQ</sub> I/O Input High Voltage | V <sub>IHQ</sub> | 2.0  | —    | V <sub>DDQ</sub> + 0.3 | V    | 1,3   |
| V <sub>DDQ</sub> I/O Input Low Voltage  | V <sub>ILQ</sub> | -0.3 | —    | 0.8                    | V    | 1,3   |

**Notes:**

1. The part numbers of Industrial Temperature Range versions end the character "I". Unless otherwise noted, all performance specifications quoted are evaluated for worst case in the temperature range marked on the device.
2. Input Under/overshoot voltage must be  $-2\text{ V} > V_i < V_{DDn} + 2\text{ V}$  not to exceed 4.6 V maximum, with a pulse width not to exceed 20% tKC.
3. V<sub>IHQ</sub> (max) is voltage on V<sub>DDQ</sub> pins plus 0.3 V.

**V<sub>DDQ2</sub> Range Logic Levels**

| Parameter                               | Symbol           | Min.                | Typ. | Max.                   | Unit | Notes |
|---|------------------|---------------------|------|------------------------|------|-------|
| V <sub>DD</sub> Input High Voltage      | V <sub>IH</sub>  | 0.6*V <sub>DD</sub> | —    | V <sub>DD</sub> + 0.3  | V    | 1     |
| V <sub>DD</sub> Input Low Voltage       | V <sub>IL</sub>  | -0.3                | —    | 0.3*V <sub>DD</sub>    | V    | 1     |
| V <sub>DDQ</sub> I/O Input High Voltage | V <sub>IHQ</sub> | 0.6*V <sub>DD</sub> | —    | V <sub>DDQ</sub> + 0.3 | V    | 1,3   |
| V <sub>DDQ</sub> I/O Input Low Voltage  | V <sub>ILQ</sub> | -0.3                | —    | 0.3*V <sub>DD</sub>    | V    | 1,3   |

**Notes:**

1. The part numbers of Industrial Temperature Range versions end the character "I". Unless otherwise noted, all performance specifications quoted are evaluated for worst case in the temperature range marked on the device.
2. Input Under/overshoot voltage must be  $-2\text{ V} > V_i < V_{DDn} + 2\text{ V}$  not to exceed 4.6 V maximum, with a pulse width not to exceed 20% tKC.
3. V<sub>IHQ</sub> (max) is voltage on V<sub>DDQ</sub> pins plus 0.3 V.

**Recommended Operating Temperatures**

| Parameter                                       | Symbol         | Min. | Typ. | Max. | Unit | Notes |
|---|----------------|------|------|------|------|-------|
| Ambient Temperature (Commercial Range Versions) | T <sub>A</sub> | 0    | 25   | 70   | °C   | 2     |
| Ambient Temperature (Industrial Range Versions) | T <sub>A</sub> | -40  | 25   | 85   | °C   | 2     |

**Notes:**

1. The part numbers of Industrial Temperature Range versions end the character "I". Unless otherwise noted, all performance specifications quoted are evaluated for worst case in the temperature range marked on the device.
2. Input Under/overshoot voltage must be  $-2\text{ V} > V_i < V_{DDn} + 2\text{ V}$  not to exceed 4.6 V maximum, with a pulse width not to exceed 20% tKC.

### Undershoot Measurement and Timing

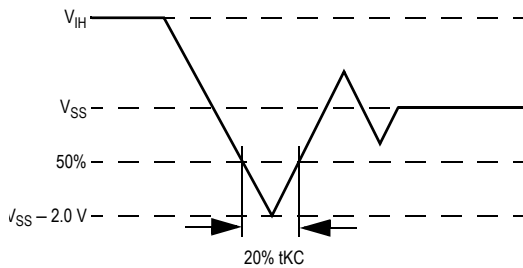

### Overshoot Measurement and Timing

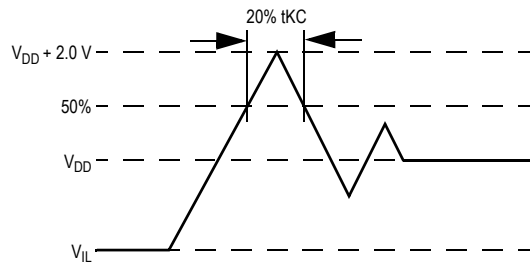

### Capacitance

( $T_A = 25^\circ\text{C}$ ,  $f = 1 \text{ MHz}$ ,  $V_{DD} = 2.5 \text{ V}$ )

| Parameter                | Symbol    | Test conditions         | Typ. | Max. | Unit |
|--------------------------|-----------|-------------------------|------|------|------|
| Input Capacitance        | $C_{IN}$  | $V_{IN} = 0 \text{ V}$  | 4    | 5    | pF   |
| Input/Output Capacitance | $C_{I/O}$ | $V_{OUT} = 0 \text{ V}$ | 6    | 7    | pF   |

**Note:**

These parameters are sample tested.

### AC Test Conditions

| Parameter              | Conditions               |
|------------------------|--------------------------|
| Input high level       | $V_{DD} - 0.2 \text{ V}$ |
| Input low level        | $0.2 \text{ V}$          |
| Input slew rate        | $1 \text{ V/ns}$         |
| Input reference level  | $V_{DD}/2$               |
| Output reference level | $V_{DDQ}/2$              |
| Output load            | <b>Fig. 1</b>            |

**Notes:**

1. Include scope and jig capacitance.
2. Test conditions as specified with output loading as shown in Fig. 1 unless otherwise noted.
3. Device is deselected as defined by the Truth Table.

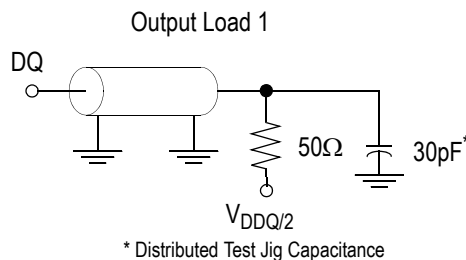

**DC Electrical Characteristics**

| Parameter                                   | Symbol    | Test Conditions   | Min                        | Max                      |
|---|-----------|---|----------------------------|--------------------------|
| Input Leakage Current<br>(except mode pins) | $I_{IL}$  | $V_{IN} = 0$ to $V_{DD}$  | -1 $\mu$ A                 | 1 $\mu$ A                |
| ZZ Input Current                            | $I_{IN1}$ | $V_{DD} \geq V_{IN} \geq V_{IH}$<br>$0 V \leq V_{IN} \leq V_{IH}$ | -1 $\mu$ A<br>-1 $\mu$ A   | 1 $\mu$ A<br>100 $\mu$ A |
| Input Current                               | $I_{IN2}$ | $V_{DD} \geq V_{IN} \geq V_{IL}$<br>$0 V \leq V_{IN} \leq V_{IL}$ | -100 $\mu$ A<br>-1 $\mu$ A | 1 $\mu$ A<br>1 $\mu$ A   |
| Output Leakage Current                      | $I_{OL}$  | Output Disable, $V_{OUT} = 0$ to $V_{DD}$                         | -1 $\mu$ A                 | 1 $\mu$ A                |
| Output High Voltage                         | $V_{OH2}$ | $I_{OH} = -8$ mA, $V_{DDQ} = 2.375$ V                             | 1.7 V                      | —                        |
| Output High Voltage                         | $V_{OH3}$ | $I_{OH} = -8$ mA, $V_{DDQ} = 3.135$ V                             | 2.4 V                      | —                        |
| Output Low Voltage                          | $V_{OL}$  | $I_{OL} = 8$ mA   | —                          | 0.4 V                    |

**Operating Currents**

| Parameter                  | Test Conditions  | Mode           | Symbol                | -333      |             | -300      |             | -250      |             | -200      |             | Unit |
|----------------------------|--|----------------|-----------------------|-----------|-------------|-----------|-------------|-----------|-------------|-----------|-------------|------|
|                            |  |                |                       | 0 to 70°C | -40 to 85°C | 0 to 70°C | -40 to 85°C | 0 to 70°C | -40 to 85°C | 0 to 70°C | -40 to 85°C |      |
| Operating Current<br>3.3 V | Device Selected;<br>All other inputs $\geq V_{IH}$ or $\leq V_{IL}$<br>Output open | (x36) Pipeline | $I_{DD}$<br>$I_{DDQ}$ | 380<br>55 | 390<br>55   | 345<br>50 | 355<br>50   | 290<br>40 | 300<br>40   | 240<br>30 | 250<br>30   | mA   |
| Operating Current<br>2.5 V | Device Selected;<br>All other inputs $\geq V_{IH}$ or $\leq V_{IL}$<br>Output open | (x36) Pipeline | $I_{DD}$<br>$I_{DDQ}$ | 380<br>55 | 390<br>55   | 345<br>05 | 355<br>50   | 290<br>40 | 300<br>40   | 240<br>30 | 250<br>30   | mA   |
| Standby Current            | $ZZ \geq V_{DD} - 0.2$ V   | — Pipeline     | $I_{SB}$              | 40        | 50          | 40        | 50          | 40        | 50          | 40        | 50          | mA   |
| Deselect Current           | Device Deselected;<br>All other inputs $\geq V_{IH}$ or $\leq V_{IL}$              | — Pipeline     | $I_{DD}$              | 85        | 90          | 80        | 85          | 85        | 90          | 75        | 80          | mA   |

**Notes:**

- $I_{DD}$  and  $I_{DDQ}$  apply to any combination of  $V_{DD3}$ ,  $V_{DD2}$ ,  $V_{DDQ3}$ , and  $V_{DDQ2}$  operation.
- All parameters listed are worst case scenario.

**AC Electrical Characteristics**

|                 | Parameter                     | Symbol            | -333 |     | -300 |     | -250 |     | -200 |     | Unit |
|-----------------|-------------------------------|-------------------|------|-----|------|-----|------|-----|------|-----|------|
|                 |                               |                   | Min  | Max | Min  | Max | Min  | Max | Min  | Max |      |
| <b>Pipeline</b> | Clock Cycle Time              | tKC               | 3.0  | —   | 3.3  | —   | 4.0  | —   | 5.0  | —   | ns   |
|                 | Clock to Output Valid         | tKQ               | —    | 2.0 | —    | 2.2 | —    | 2.3 | —    | 2.7 | ns   |
|                 | Clock to Output Invalid       | tKQX              | 1.0  | —   | 1.0  | —   | 1.0  | —   | 1.0  | —   | ns   |
|                 | Clock to Output in Low-Z      | tLZ <sup>1</sup>  | 1.0  | —   | 1.0  | —   | 1.0  | —   | 1.0  | —   | ns   |
|                 | Setup time                    | tS                | 1.0  | —   | 1.1  | —   | 1.2  | —   | 1.4  | —   | ns   |
|                 | Hold time                     | tH                | 0    | —   | 0.1  | —   | 0.2  | —   | 0.4  | —   | ns   |
|                 | $\bar{G}$ to Output Valid     | tOE               | —    | 2.0 | —    | 2.2 | —    | 2.3 | —    | 2.5 | ns   |
|                 | $\bar{G}$ to output in High-Z | tOHZ <sup>1</sup> | —    | 2.0 | —    | 2.2 | —    | 2.3 | —    | 2.5 | ns   |
|                 | Clock HIGH Time               | tKH               | 1.3  | —   | 1.3  | —   | 1.3  | —   | 1.3  | —   | ns   |
|                 | Clock LOW Time                | tKL               | 1.5  | —   | 1.5  | —   | 1.5  | —   | 1.5  | —   | ns   |
|                 | Clock to Output in High-Z     | tHZ <sup>1</sup>  | 1.0  | 2.0 | 1.0  | 2.2 | 1.5  | 2.3 | 1.5  | 3.0 | ns   |
|                 | $\bar{G}$ to output in Low-Z  | tOLZ <sup>1</sup> | 0    | —   | 0    | —   | 0    | —   | 0    | —   | ns   |
|                 | ZZ setup time                 | tZZS <sup>2</sup> | 5    | —   | 5    | —   | 5    | —   | 5    | —   | ns   |
|                 | ZZ hold time                  | tZZH <sup>2</sup> | 1    | —   | 1    | —   | 1    | —   | 1    | —   | ns   |
|                 | ZZ recovery                   | tZZR              | 20   | —   | 20   | —   | 20   | —   | 20   | —   | ns   |

**Notes:**

1. These parameters are sampled and are not 100% tested.
2. ZZ is an asynchronous signal. However, in order to be recognized on any given clock cycle, ZZ must meet the specified setup and hold times as specified above.

Pipeline Mode Timing (+1)

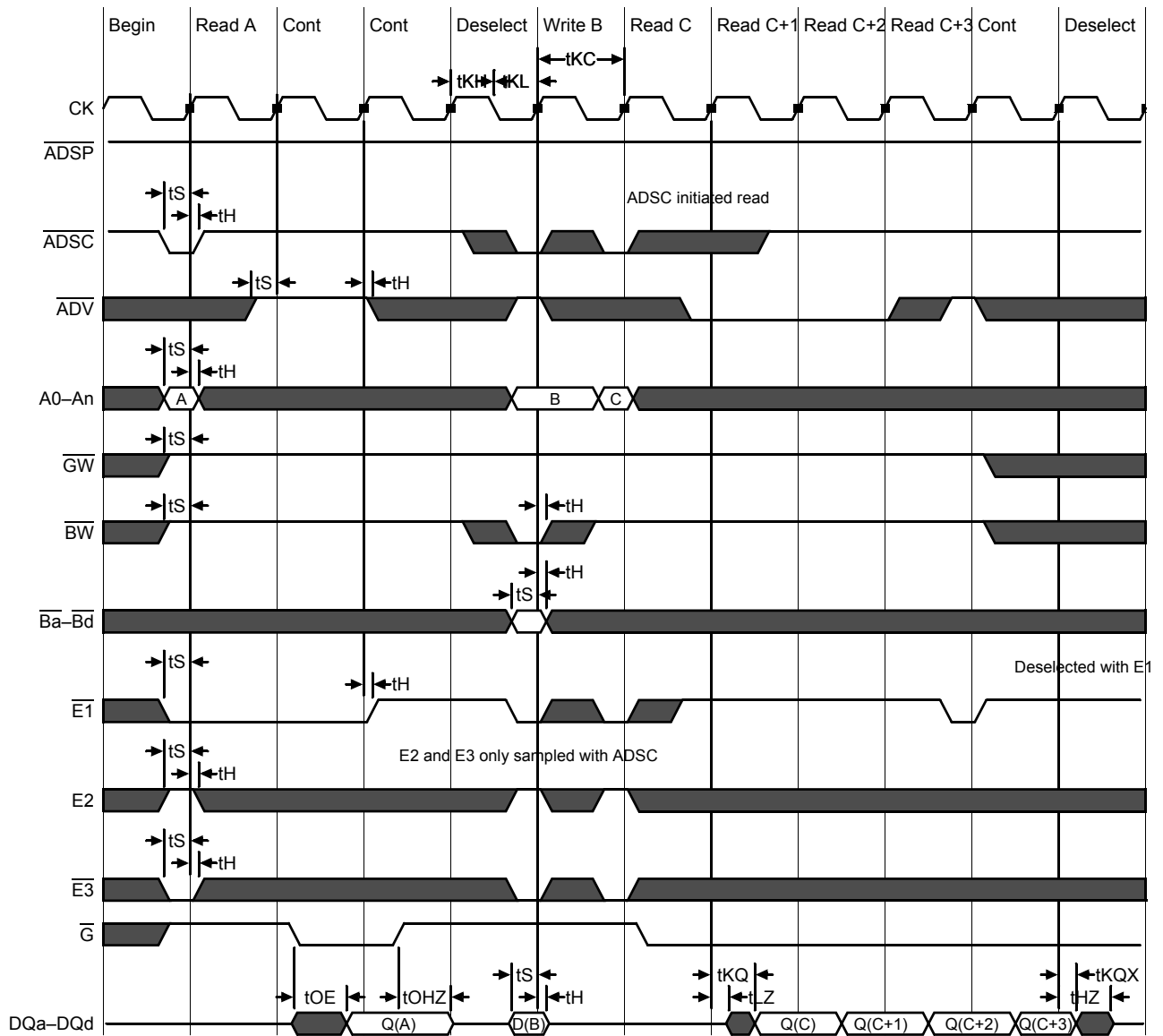

## Sleep Mode

During normal operation, ZZ must be pulled low, either by the user or by its internal pull down resistor. When ZZ is pulled high, the SRAM will enter a Power Sleep mode after 2 cycles. At this time, internal state of the SRAM is preserved. When ZZ returns to low, the SRAM operates normally after ZZ recovery time.

Sleep mode is a low current, power-down mode in which the device is deselected and current is reduced to  $I_{SB2}$ . The duration of Sleep mode is dictated by the length of time the ZZ is in a High state. After entering Sleep mode, all inputs except ZZ become disabled and all outputs go to High-Z. The ZZ pin is an asynchronous, active high input that causes the device to enter Sleep mode. When the ZZ pin is driven high,  $I_{SB2}$  is guaranteed after the time  $t_{ZZI}$  is met. Because ZZ is an asynchronous input, pending operations or operations in progress may not be properly completed if ZZ is asserted. Therefore, Sleep mode must not be initiated until valid pending operations are completed. Similarly, when exiting Sleep mode during  $t_{ZZR}$ , only a Deselect or Read commands may be applied while the SRAM is recovering from Sleep mode.

**Sleep Mode Timing Diagram**

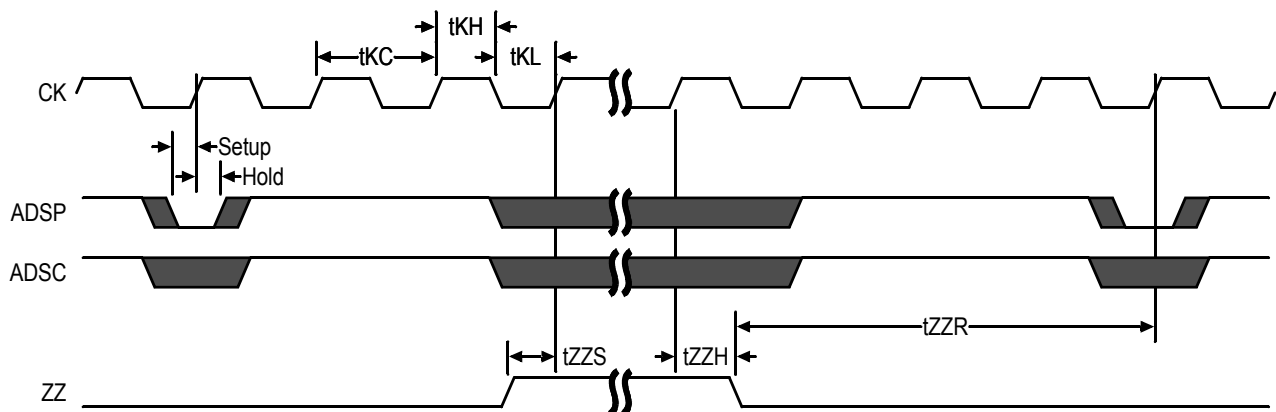

## Application Tips

### Single and Dual Cycle Deselect

SCD devices (like this one) force the use of “dummy read cycles” (read cycles that are launched normally but that are ended with the output drivers inactive) in a fully synchronous environment. Dummy read cycles waste performance but their use usually assures there will be no bus contention in transitions from reads to writes or between banks of RAMs. DCD SRAMs do not waste bandwidth on dummy cycles and are logically simpler to manage in a multiple bank application (wait states need not be inserted at bank address boundary crossings) but greater care must be exercised to avoid excessive bus contention.



TQFP Package Drawing (Package T)

| Symbol   | Description        | Min. | Nom. | Max  |
|----------|--------------------|------|------|------|
| A1       | Standoff           | 0.05 | 0.10 | 0.15 |
| A2       | Body Thickness     | 1.35 | 1.40 | 1.45 |
| b        | Lead Width         | 0.20 | 0.30 | 0.40 |
| c        | Lead Thickness     | 0.09 | —    | 0.20 |
| D        | Terminal Dimension | 21.9 | 22.0 | 22.1 |
| D1       | Package Body       | 19.9 | 20.0 | 20.1 |
| E        | Terminal Dimension | 15.9 | 16.0 | 16.1 |
| E1       | Package Body       | 13.9 | 14.0 | 14.1 |
| e        | Lead Pitch         | —    | 0.65 | —    |
| L        | Foot Length        | 0.45 | 0.60 | 0.75 |
| L1       | Lead Length        | —    | 1.00 | —    |
| Y        | Coplanarity        |      |      | 0.10 |
| $\theta$ | Lead Angle         | 0°   | —    | 7°   |

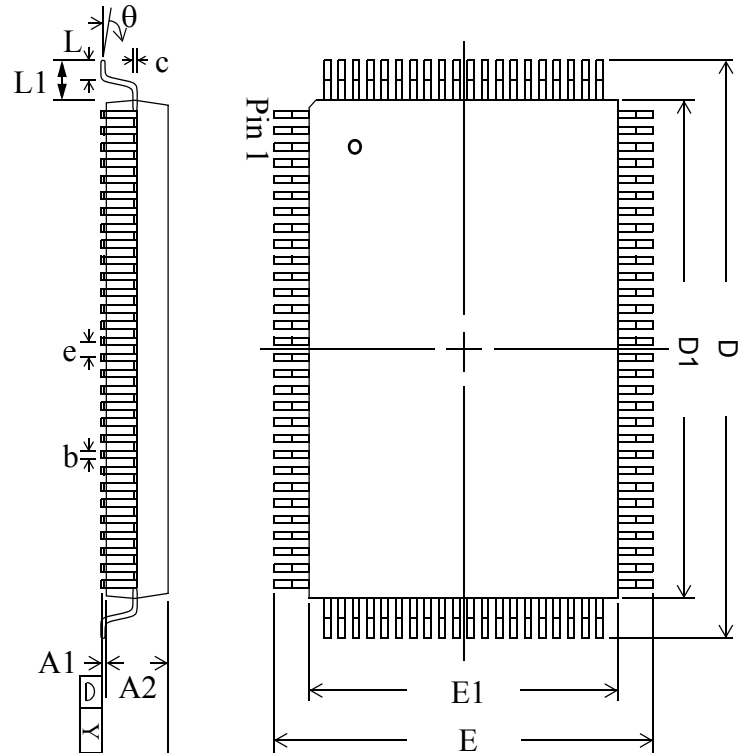

Notes:

1. All dimensions are in millimeters (mm).
2. Package width and length do not include mold protrusion.

**Ordering Information for GSI Synchronous Burst RAMs**

| Org       | Part Number <sup>1</sup> | Type     | Package      | Speed <sup>2</sup><br>(MHz/ns) | T <sub>A</sub> <sup>3</sup> | Status |
|-----------|--------------------------|----------|--------------|--------------------------------|-----------------------------|--------|
| 256K x 36 | GS88037BT-333            | Pipeline | TQFP         | 333                            | C                           |        |
| 256K x 36 | GS88037BT-300            | Pipeline | TQFP         | 300                            | C                           |        |
| 256K x 36 | GS88037BT-250            | Pipeline | TQFP         | 250                            | C                           |        |
| 256K x 36 | GS88037BT-200            | Pipeline | TQFP         | 200                            | C                           |        |
| 256K x 36 | GS88037BT-333I           | Pipeline | TQFP         | 333                            | I                           |        |
| 256K x 36 | GS88037BT-300I           | Pipeline | TQFP         | 300                            | I                           |        |
| 256K x 36 | GS88037BT-250I           | Pipeline | TQFP         | 250                            | I                           |        |
| 256K x 36 | GS88037BT-200I           | Pipeline | TQFP         | 200                            | I                           |        |
| 256K x 36 | GS88037BGT-333           | Pipeline | Pb-free TQFP | 333                            | C                           |        |
| 256K x 36 | GS88037BGT-300           | Pipeline | Pb-free TQFP | 300                            | C                           |        |
| 256K x 36 | GS88037BGT-250           | Pipeline | Pb-free TQFP | 250                            | C                           |        |
| 256K x 36 | GS88037BGT-200           | Pipeline | Pb-free TQFP | 200                            | C                           |        |
| 256K x 36 | GS88037BGT-333I          | Pipeline | Pb-free TQFP | 333                            | I                           |        |
| 256K x 36 | GS88037BGT-300I          | Pipeline | Pb-free TQFP | 300                            | I                           |        |
| 256K x 36 | GS88037BGT-250I          | Pipeline | Pb-free TQFP | 250                            | I                           |        |
| 256K x 36 | GS88037BGT-200I          | Pipeline | Pb-free TQFP | 200                            | I                           |        |

**Notes:**

1. Customers requiring delivery in Tape and Reel should add the character "T" to the end of the part number. Example: GS88037BT-200IT.
2. T<sub>A</sub> = C = Commercial Temperature Range. T<sub>A</sub> = I = Industrial Temperature Range.
3. GSI offers other versions this type of device in many different configurations and with a variety of different features, only some of which are covered in this data sheet. See the GSI Technology web site ([www.gsitechnology.com](http://www.gsitechnology.com)) for a complete listing of current offerings.

**9Mb Sync SRAM Datasheet Revision History**

| DS/DateRev. Code: Old;<br>New | Types of Changes<br>Format or Content | Page;Revisions;Reason   |
|-------------------------------|---------------------------------------|---|
| 88037B_r1                     |                                       | • Creation of new datasheet                                       |
| 88037B_r1; 88037B_r1_01       | Content                               | • Corrected ordering information (incorrect speed bins corrected) |
| 88037B_r1_01;<br>88037B_r1_02 | Content/Format                        | • Updated format<br>• Deleted unneeded speed bins (275 & 225 MHz) |
| 88037B_r1_02;<br>88037B_r1_03 | Content/Format                        | • Added Pb-free information for TQFP                              |
| 88037B_r1_03;<br>88037B_r1_04 | Content                               | • Removed erroneous numeral from address pin (Pin 48)             |