

Top View

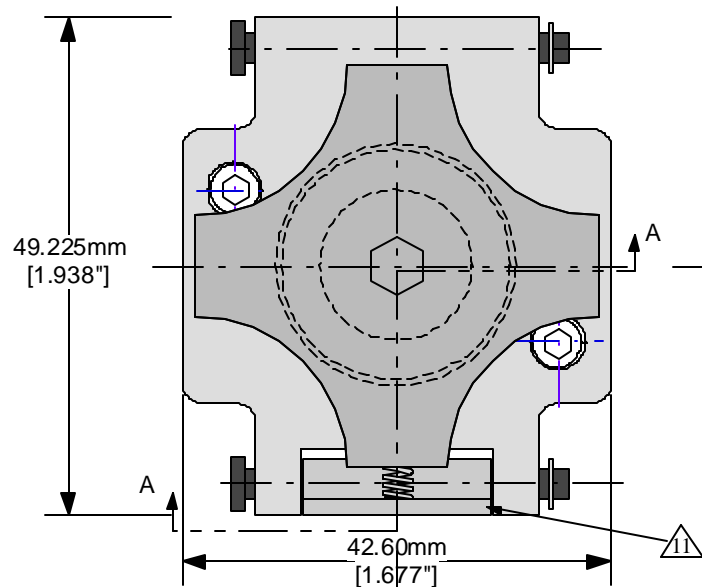

Side View
(Section AA)

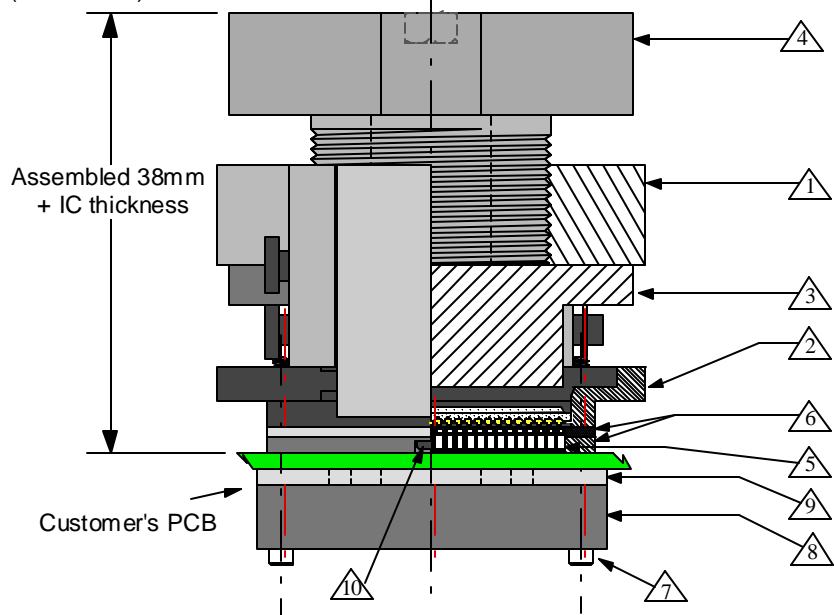

Features

- Directly mounts to target PCB (needs tooling holes) with hardware
- Minimum real estate required
- Compression plate distributes evenly
- Clamshell lid

Materials:

- 1 Clam Shell Lid: Black anodized 7075 Aluminum. Height = 20 mm.
- 2 Socket Base: Black anodized 7075 Aluminum. Height = 6 mm.
- 3 Compression Plate: Black anodized 7075 Aluminum. Thickness = 12 mm.
- 4 Compression Screw: Clear anodized 7075 Aluminum. Height = 27 mm, Fluted Knob
- 5 Pogo Pin:
Plungers - Hardened Steel/ Gold plated
Barrel - Copper Alloy/ Gold plated
Spring - Stainless Steel/ Gold wire
- 6 Pogo Pin Guides: Ultem 1000.
- 7 Socket Base Screw: Socket Head Cap Screw, 18-8 SS, 0-80 Thread, 3/4" long.
- 8 Backing Plate: Black anodized 7075 Aluminum
- 9 Insulation Plate: FR4/G10
- 10 Pogo Pin Guide Screw: Pan head phillips, 18-8 SS, 0-80 thread, 3/16" long.
- 11 Latch: Black anodized 7075 Aluminum.

All Tolerances: $\pm 0.125\text{mm}$ (unless stated otherwise). Materials and specifications are subject to change without notice.

SS-BGA256B-01 Drawing

© 2004 IRONWOOD ELECTRONICS, INC.
PO BOX 21151 ST. PAUL, MN 55121
Tele: (651) 452-8100
www.ironwoodelectronics.com

Status: Released

Scale: 1.25:1

Rev: B

Drawing: H. Hansen

Date: 5/14/04

File: SS-BGA256B-01 Dwg

Modified: 1/21/05

PAGE 1 of 4

***Note: BGA pattern is not symmetrical with respect to the mounting holes.**

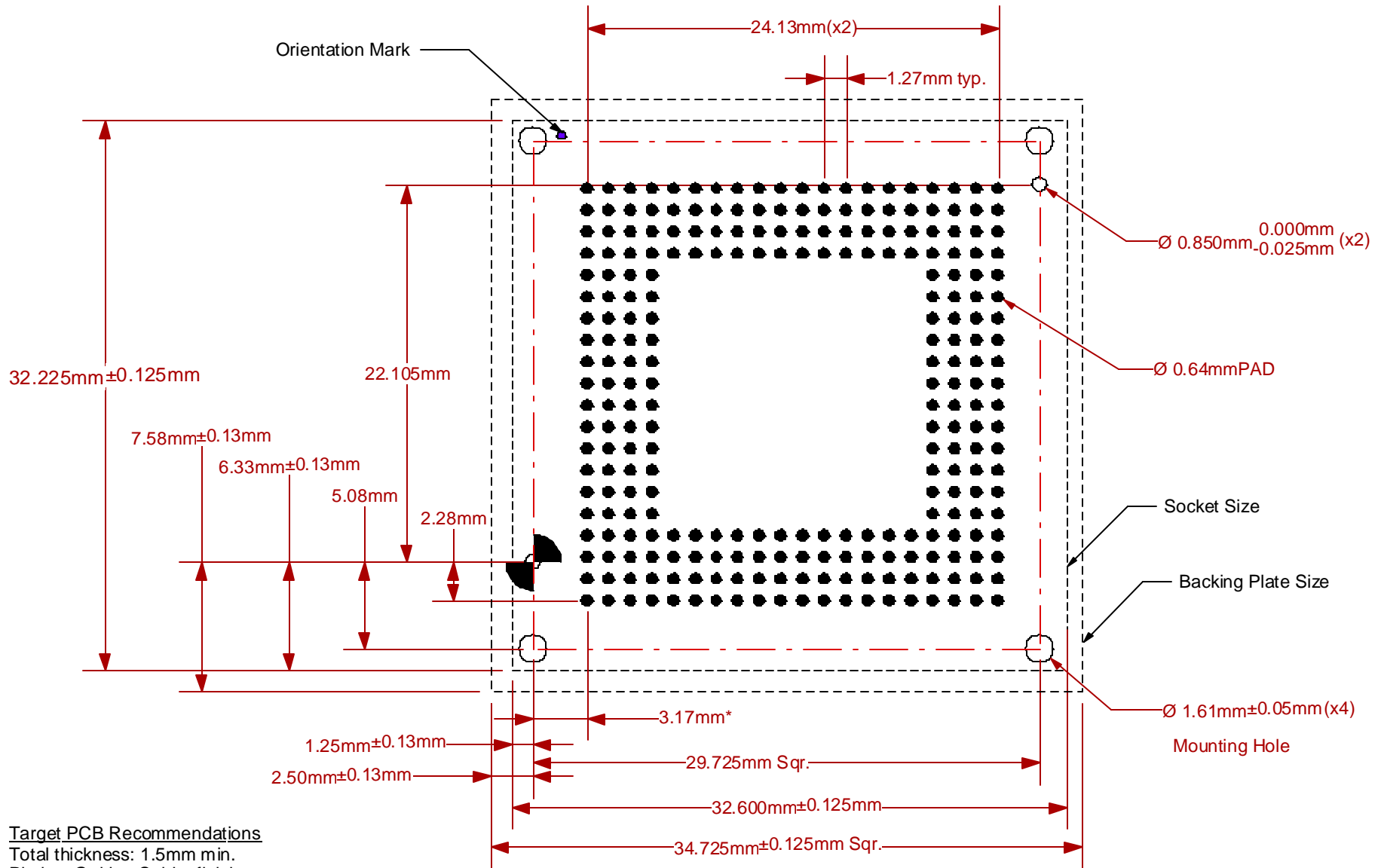

Target PCB Recommendations
Total thickness: 1.5mm min.
Plating: Gold or Solder finish

Recommended PCB Layout Tolerances: ±0.025mm [±0.001"] unless stated otherwise.

 <p>© 2004 IRONWOOD ELECTRONICS, INC. PO BOX 21151 ST. PAUL, MN 55121 Tele: (651) 452-8100 www.ironwoodelectronics.com</p>	<p>SS-BGA256B-01 Drawing</p>	<p>Status: Released</p>	<p>Scale: 3:1</p>	<p>Rev: B</p>
	<p>Drawing: H. Hansen</p>	<p>Date: 5/14/04</p>		
	<p>File: SS-BGA256B-01 Dwg</p>	<p>Modified: 1/21/05</p>		

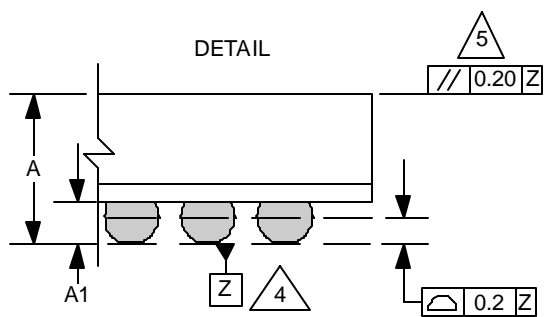
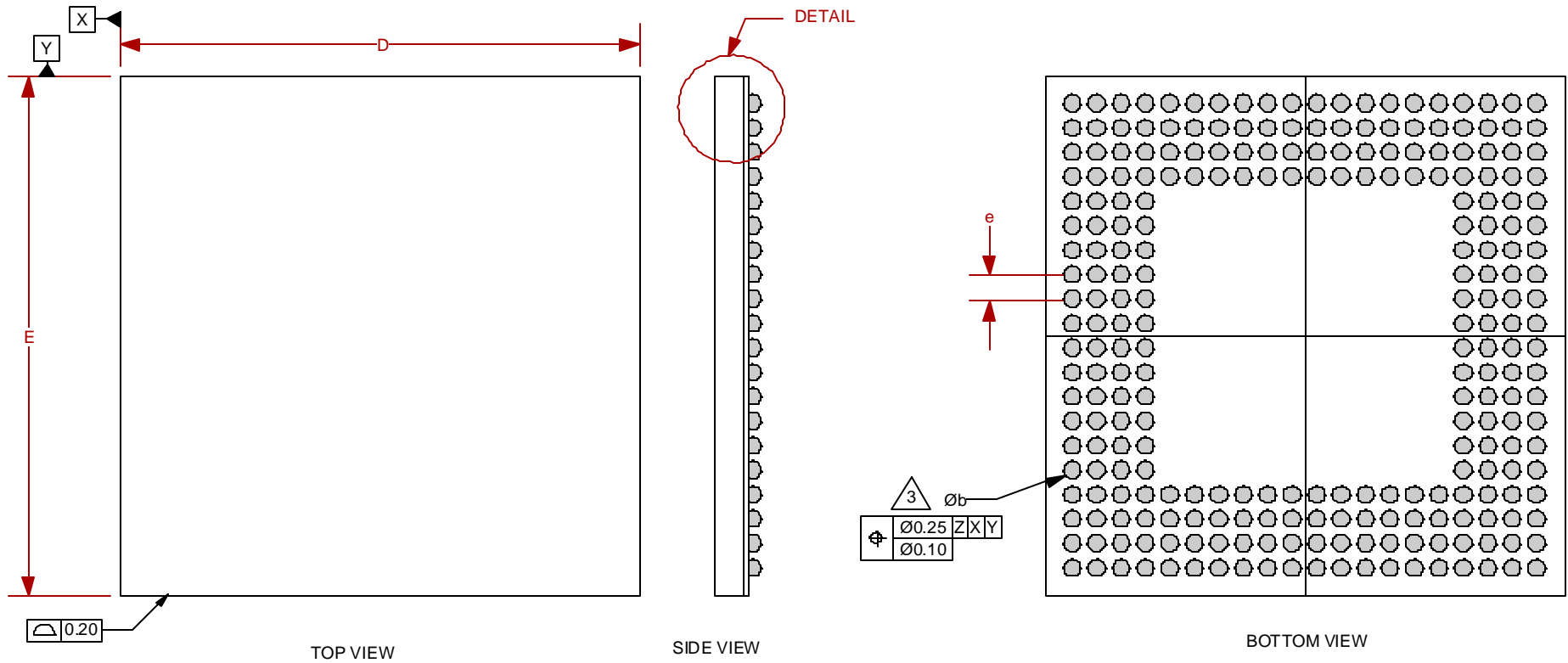

1. Dimensions are in millimeters.
 2. Interpret dimensions and tolerances per ASME Y14.5M-1994.
- Dimension b is measured at the maximum solder ball diameter, parallel to datum plane Z.
 - Datum Z (seating plane) is defined by the spherical crowns of the solder balls.
 - Parallelism measurement shall exclude any effect of mark on top surface of package.

DIM	MIN	MAX
A		3.5
A1	0.5	0.7
b		0.90
D	27.00 BSC	
E	27.00 BSC	
e	1.27 BSC	

20x20 Array

	SS-BGA256B-01 Drawing		Status: Released	Scale:	Rev: B
	© 2004 IRONWOOD ELECTRONICS, INC. PO BOX 21151 ST. PAUL, MN 55121 Tele: (651) 452-8100 www.ironwoodelectronics.com		Drawing: H. Hansen		Date: 5/14/04
			File: SS-BGA256B-01 Dwg		Modified: 1/21/05

Top View

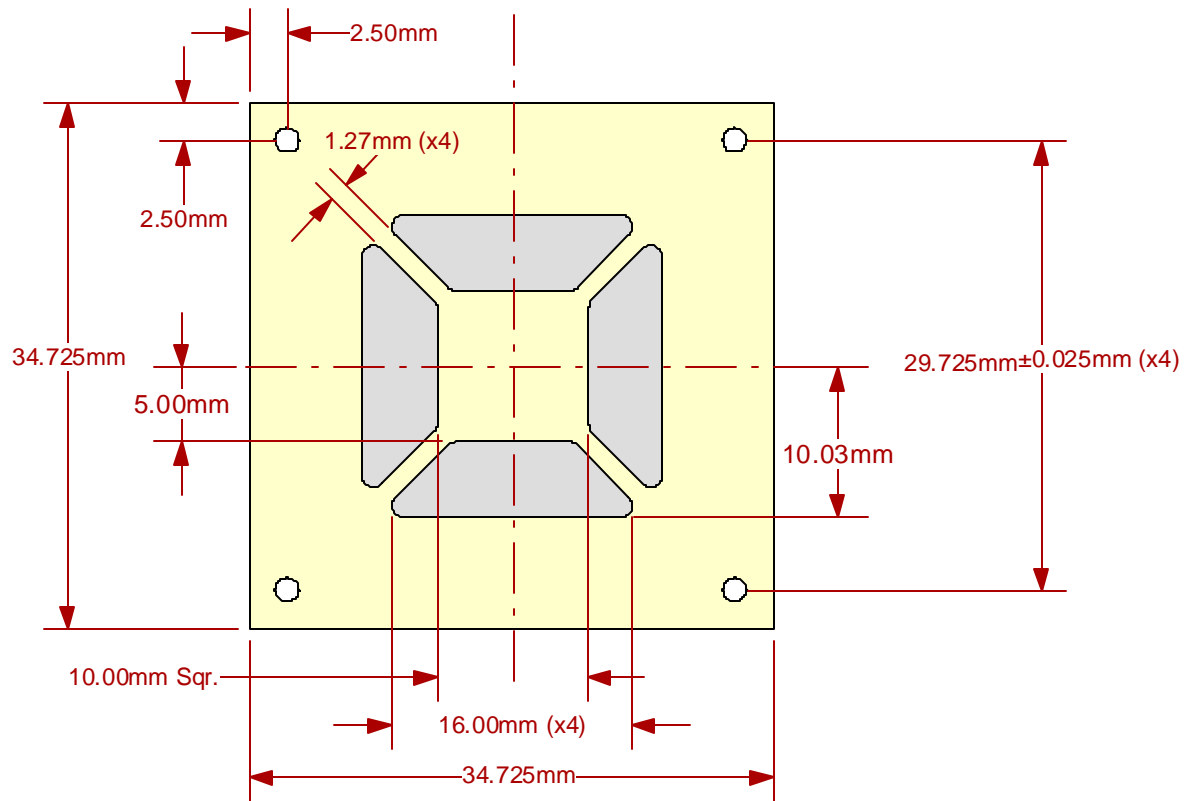

Side View

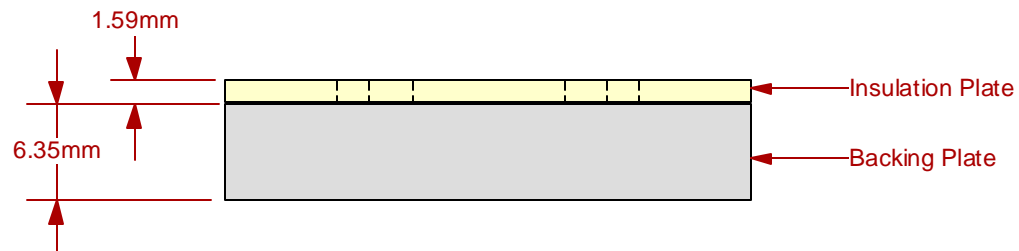

Description: Backing Plate with Insulation Plate

	SS-BGA256B-01 Drawing	Status: Released	Scale:	Rev: B
	© 2004 IRONWOOD ELECTRONICS, INC. PO BOX 21151 ST. PAUL, MN 55121 Tele: (651) 452-8100 www.ironwoodelectronics.com	Drawing: H. Hansen		Date: 5/14/04
		File: SS-BGA256B-01 Dwg	Modified: 1/21/05	

All dimensions are in mm.
 All tolerances are +/- 0.125mm.
 (Unless stated otherwise)