

DATE	REVISIONS	REV
9-30-96	E.C.N. #10247./	A
1-5-98	E.C.N. #10BRDR./	B

DRAWING NUMBER	REV
OED-ST-8L	B

**UNCONTROLLED DOCUMENT**  
ELECTRO-OPTICAL CHARACTERISTICS  $T_A = 25^\circ\text{C}$

PARAMETER	SYMBOL	TEST CONDITION	MIN	TYP	MAX	UNIT
COLLECTOR DARK CURRENT	$I_{ce0}$	$V_{ce0} = 10\text{V}$ $E_e = 0.5\text{mw/cm}^2$		1	100	nA
COLLECTOR LIGHT CURRENT	$I_c$	$V_{ce} = 3\text{V}$ $E_e = 0.5\text{mw/cm}^2$	1.0	10		mA
COLLECTOR-EMITTER SATURATION VOLTAGE	$V_{ce}(\text{sat})$	$I_c = 0.2\text{mA}$ $E_e = 0.5\text{mw/cm}^2$			1.0	V
SWITCHING SPEEDS:		$V_{cc} = 5\text{V}$				
RISING TIME	$T_r$	$I_c = 1\text{mA}$		40		$\mu\text{S}$
FALLING TIME	$T_f$	$R_I = 100\Omega$		60		$\mu\text{S}$
PEAK WAVELENGTH	$\lambda_p$			880		nm
ANGULAR RESPONSE	$\Delta\theta$			$\pm 20$		DEG
LENS COLOR:	CLEAR					

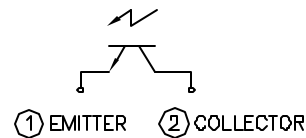
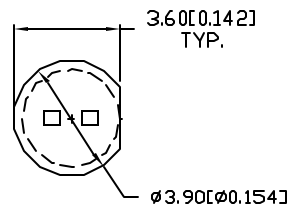
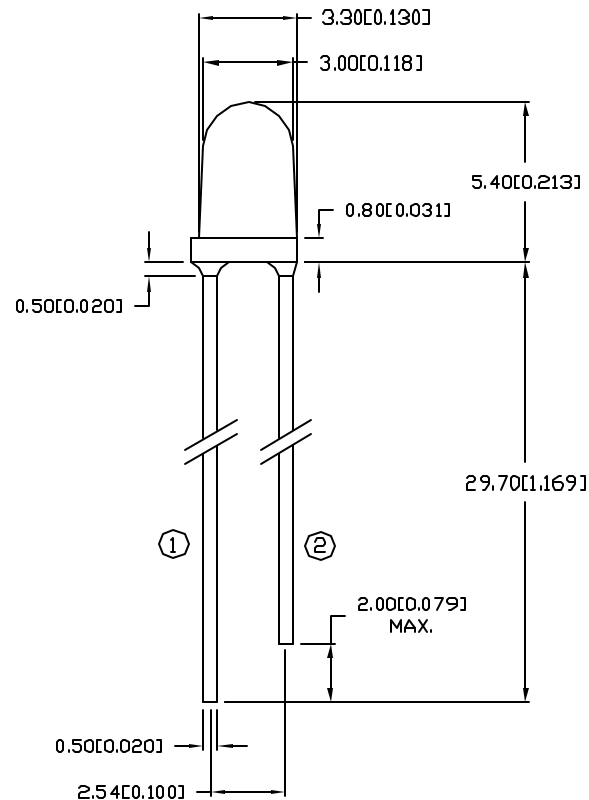

LIMITS OF SAFE OPERATION AT 25°C

PARAMETER	MAX	UNITS
COLLECTOR-EMITTER VOLTAGE ( $V_{ce0}$ )	20	V
EMITTER-COLLECTOR VOLTAGE ( $V_{eco}$ )	5	V
POWER DISSIPATION	75	mW
OPERATING TEMP.	-20 TO +80	$^\circ\text{C}$
STORAGE TEMP.	-20 TO +80	$^\circ\text{C}$
SOLDERING TEMP.	+260	$^\circ\text{C}$
2.0mm FROM BODY	3 SEC. MAX	

**RELIABILITY NOTE**

OUR MANY YEARS OF EXPERIENCE DATA ACCUMULATION INDICATE THAT SOLDER HEAT IS A MAJOR CAUSE OF EARLY AND FUTURE FAILURE. PLEASE PAY ATTENTION TO YOUR SOLDERING PROCESS.

**LUMEX**  
INCORPORATED

290 E. HELLEN ROAD  
PALATINE, ILLINOIS 60067  
(847) 359-2790

CONFIDENTIAL INFORMATION  
THE INFORMATION CONTAINED IN THIS DOCUMENT IS THE PROPERTY OF LUMEX INCORPORATED. EXCEPT AS SPECIFICALLY AUTHORIZED IN WRITING BY LUMEX INCORPORATED, THE HOLDER OF THIS DOCUMENT SHALL KEEP ALL INFORMATION CONTAINED HEREIN CONFIDENTIAL AND SHALL PROTECT SAME IN WHOLE OR IN PART FROM DISCLOSURE AND DISSEMINATION TO ALL THIRD PARTIES.

DATE: 7-9-93	DWN:	CHK'D:	APPD:
SCALE: N/A			

NPN SILICON PHOTOTRANSISTOR,  
WATER CLEAR LENS.

PAGE 1 OF 1	DRAWING NUMBER OED-ST-8L	REV B
-------------	-----------------------------	----------

**UNCONTROLLED DOCUMENT**

UNLESS OTHERWISE SPECIFIED TOLERANCE IS  $\pm 0.25\text{mm}$  ( $\pm 0.010"$ )