

LM3466

Smart Linear LED Driver for Multi-Channel LED Systems

General Description

The LM3466 integrates a linear LED driver for lighting systems which consist of multiple LED strings powered by a constant current power supply. It equalizes the current provided by the supply in a pre-set ratio for each active LED string, where an active string is a fully turned on LED string, regardless of the number of strings connected to the supply or the forward voltage of each LED string. If any LED string opens during operation, the LM3466 automatically equalizes the supply current through all of the remaining active LED strings. As a result, the overall brightness of the lighting system is maintained even if some LED strings open during operation.

The LM3466 lighting system is simple to design owing to a proprietary control scheme. To minimize the component count, the LM3466 integrates a 70V, 1.5A N-channel power MOSFET with a current limit of 2.06A. To add one more LED string to the system, only a single resistor, a capacitor, and a LM3466 are required. Other supervisory features of the LM3466 include under-voltage lock-out, fault reporting, thermal latch off, and thermal shutdown protection.

The LM3466 consists of only linear circuitry so that the EMI of the application circuit is not deteriorated. The LM3466 lighting system is EMI friendly if the constant current power supply used is complied to EMI standards. The LM3466 is available in the PSOP-8 exposed DAP package.

Features

- Easy to design and use for lighting systems consisting of multiple LED strings (support modular design)
- Automatically equalizes the current of every active LED string, even the forward voltage of each string is different
- Easy to pre-set and fine-tune current ratio among LED strings (e.g. color temperature adjustment or CRI enhancement)
- $\pm 1\%$ current accuracy at room temperature and $\pm 1.5\%$ over temperature
- Maintains constant output power if some strings open (inactive) by automatically equalizing the current of remaining active LED strings
- Works with a constant current power supply (ac/dc or dc/dc), and no communication to/from the constant current power supply is required
- Operates with minimum voltage overhead to maximize power efficiency
- Wide input voltage range from 6V to 70V
- Fault status output
- Thermal shutdown
- Integrated 70V 1.5A MOSFET with 2.06A current limit
- Maximum 70V per LED string, 20 LEDs
- Linear circuitry does not deteriorate EMI
- PSOP-8 exposed DAP package

Applications

- Street lamps
- Solid state lighting systems

Typical Application

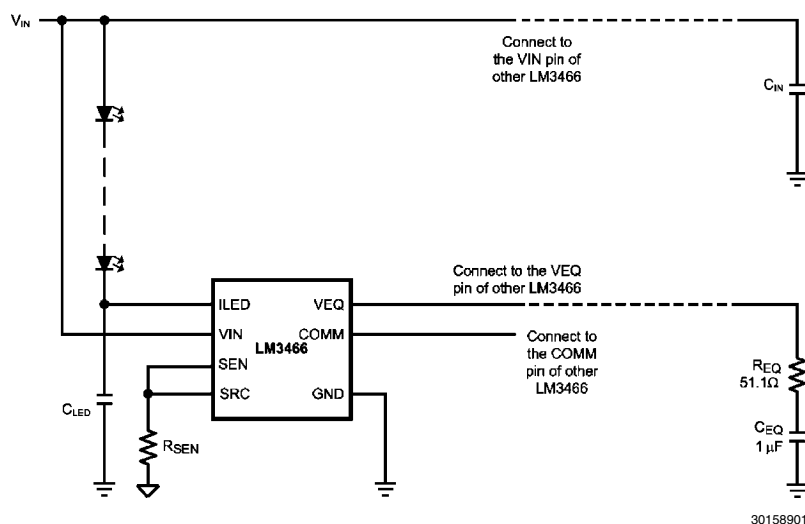

Connection Diagram

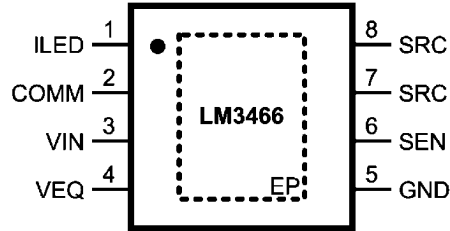

30158902

Ordering Information

Order Number	Spec.	Package Type	NSC Package Drawing	Supplied As
LM3466MR	NOPB	ePSOP-8	MRA08A	95 Units in Anti-Static Rails
LM3466MRX				2500 units on Tape and Reel

Pin Descriptions

Pin	Name	Description	Application Information
1	ILED	Current Regulator Input	Connects to the drain of the integrated power MOSFET. Connects this pin to the cathode of an LED string. Connects a capacitor from this pin to ground to minimize noise if the connecting cable to the LED string is long.
2	COMM	Open-drain Status Output	Indicates the status of the LM3466 including startup, LED string active/inactive, TSD.
3	VIN	Input Voltage Supply	Connects to voltage supply from 6V to 70V. Connects a 10 nF capacitor from this pin to ground for decoupling.
4	VEQ	Control Voltage	Connects to the VEQ pin of other LM3466 with a 51Ω resistor in series with a 1 μF capacitor to ground.
5	GND	Ground	Connects to ground.
6	SEN	Current Sense Input	Senses the voltage of an external current sensing resistor.
7,8	SRC	Source of Power MOSFET	Connects to the source of the integrated power MOSFET. Connects this pin to an external current sensing resistor.
DAP	DAP	Exposed Pad	Thermal connection pad. Connects to a ground plane.

Absolute Maximum Ratings *(Note 1)*

If Military/Aerospace specified devices are required, please contact the Texas Instruments Sales Office/Distributors for availability and specifications.

V _{IN} , I _{LED} to GND	-0.3V to 75V
COMM to GND	-0.3V to 7V
SEN, SRC, VEQ to GND	-0.3V to 5V
ESD Rating	

Human Body Model	±2 kV
Storage Temperature Range	-65°C to + 150°C
Junction Temperature (T _J)	+ 150°C

Operating Ratings

Supply Voltage Range (V _{IN})	6V to 70V
Junction Temperature Range (T _J)	-40°C to + 125°C
Thermal Resistance (θ _{JC})	12.8 °C/W

Electrical Characteristics Specification with standard type are for T_A = T_J = +25°C only; limits in **boldface** type apply over the full Operating Junction Temperature (T_J) range. Minimum and Maximum are guaranteed through test, design or statistical correlation. Typical values represent the most likely parametric norm at T_J = +25°C, and are provided for reference purposes only. Unless otherwise stated, the following conditions apply: V_{IN} = 48V.

Symbol	Parameter	Conditions	Min	Typ	Max	Units
V _{IN-UVLO-UPPER}	V _{IN} pin under-voltage lockout (UVLO) upper threshold	V _{IN} increasing	4.06	4.78	5.30	V
V _{IN-UVLO-HYS}	V _{IN} pin UVLO hysteresis	V _{IN} decreasing		0.52		V
I _{IN}	Operating current to the V _{IN} pin			550	640	μA
V _{SEN}	The SEN pin voltage regulation	V _{EQ} = 200 mV	197.1	200	201.0	mV
			195.6	200	201.5	mV
I _{SEN}	SEN pin bias current out	V _{SEN} = 0V	9.77	10.5	11.23	μA
I _{LED-OFF}	I _{LED} pin off current	V _{I_{LED}} = 70V		0.1	0.6	μA
R _{DS(on)}	Integrated power MOSFET on-resistance	I _{I_{LED}} = 300 mA		0.5	1.2	Ω
V _{SRC-OPEN}	SRC pin open circuit threshold	V _{SEN} = V _{SRC} ; V _{COMM} = 0V	25	31	37	mV
I _{LIMIT}	Current Limit	V _{SEN} = V _{SRC} = 0V, V _{I_{LED}} = 3V	1.75	2.06	2.35	A
COMM _{I_{LOW}}	COMM pin pull-low current	V _{COMM} = 5V		34	54	μA
COMM _{V_{HIGH}}	COMM pin pull-high voltage	COMM pin to ground through a 10 kΩ		6.0		V
T _{SD}	Thermal Shutdown			150		°C

Note 1: Absolute Maximum Ratings are limits beyond which damage to the device may occur. Operating Ratings are conditions under which operation of the device is intended to be functional. For guaranteed specifications and test conditions, see the Electrical Characteristics.

Note 2: The human body model is a 100 pF capacitor discharged through a 1.5 kΩ resistor into each pin.

Note 3: θ_{JC} measurements are performed in general accordance with Mil-Std 883B, Method 1012.1 and utilize the copper heat sink technique. Copper Heat Sink @ 18°C with an ambient temperature @ 22°C.

Typical Performance Characteristics Unless otherwise specified the following conditions apply: $T_J = 25^\circ\text{C}$, $V_{IN} = 48\text{V}$ with configuration in the additional application circuit for $I_{LED} = 0.35\text{A}$ shown in this datasheet.

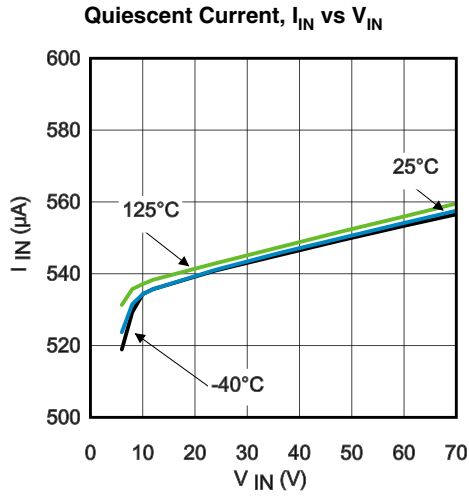

30158926

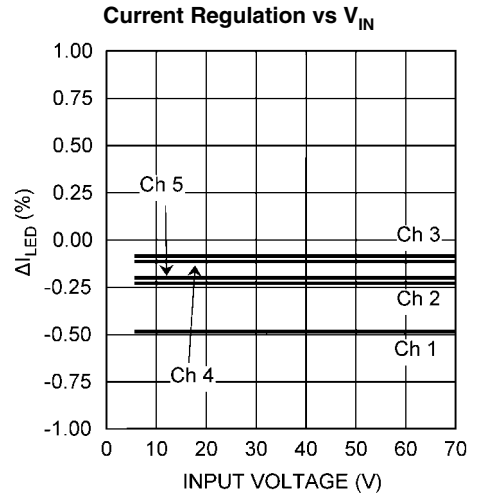

30158904

Current Regulation (Channel to Channel) vs Temperature

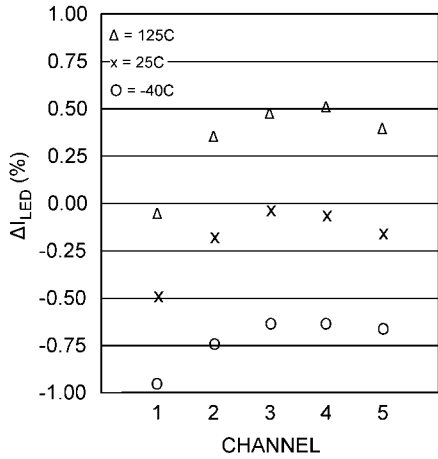

30158922

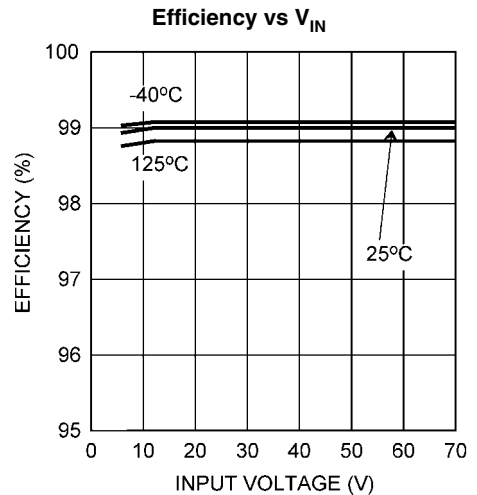

30158906

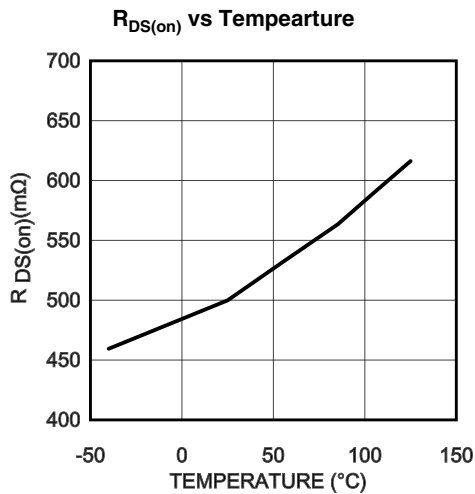

30158921

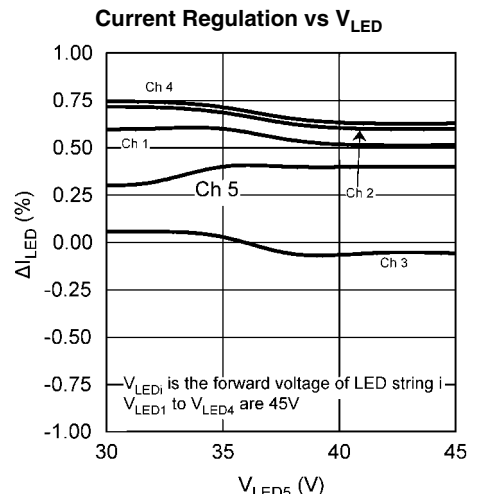

30158923

Power Up

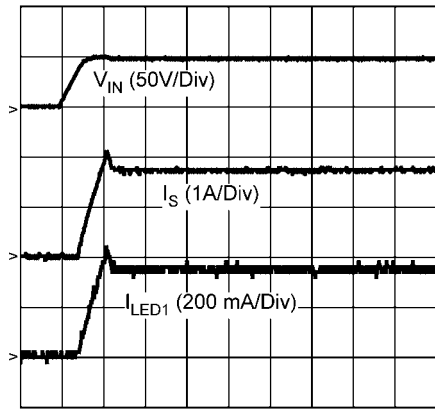

TIME (20 ms/DIV)

30158909

LED String Disconnect

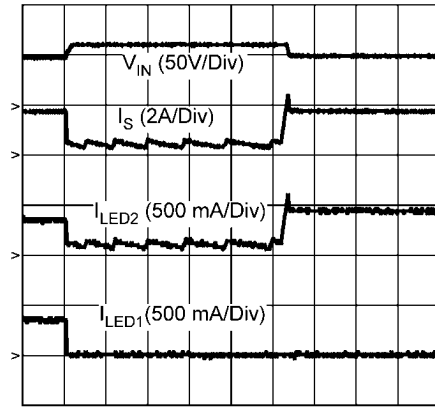

TIME (100 ms/DIV)

30158910

I_{SEN} vs Temperature

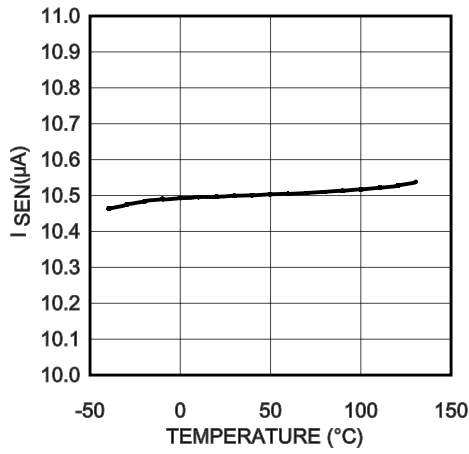

30158924

Current Limit vs Temperature

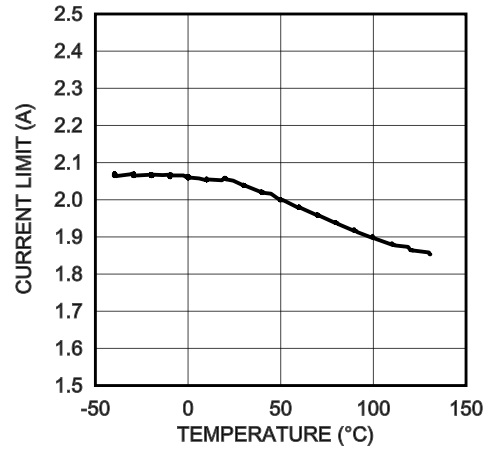

30158925

Block Diagram

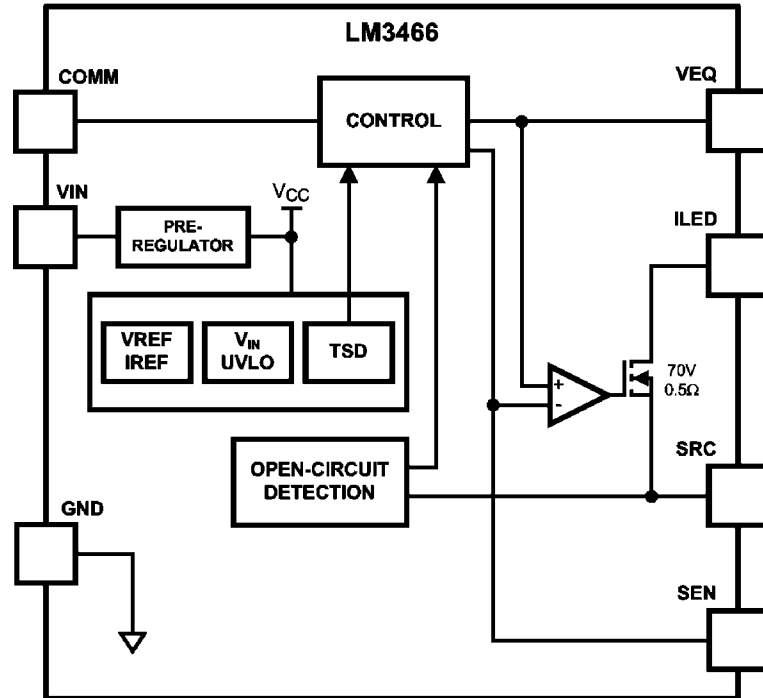

30158929

Overview

The LM3466 integrates a linear LED driver for lighting systems which consist of multiple LED strings powered by a constant current power supply. An ideal constant current power supply delivers a constant current (I_S) regardless of the output voltage of the connecting load. In the lighting system, each LM3466 regulates the current of an LED string. The current I_S provided by the supply is equalized (i.e. shared in a pre-set ratio determined by a single resistor) through each active LED string automatically, regardless of the number of strings connected to the supply or the forward voltage of each string. Here, an active LED string refers to a fully turned on LED string. If any LED string opens during operation, the LED current of all remaining active LED strings will increase to equalize the current provided by the supply automatically. As a result, the total output power remains nearly the same in case of the decrease of active LED strings. This gives an advantage that the overall brightness of the lighting system is maintained even if some LED strings open during operation.

A LM3466 lighting system is simple to design owing to a proprietary control scheme. To minimize the component count, the LM3466 integrates a 70V, 1.5A N-channel MOSFET with a current limit of 2.06A. To add one more LED string to the system, only a single resistor, a capacitor, and an LM3466 are required. Other supervisory features of the LM3466 include under-voltage lock-out, fault reporting, thermal latchoff, and thermal shutdown protection.

The LM3466 consists of only linear circuitry so that the EMI of the application circuit is not deteriorated. The LM3466 lighting system is EMI friendly if the constant current power supply used is complied to EMI standards. The LM3466 is available in a PSOP-8 exposed DAP package.

Current Regulator

The LM3466 integrates a current regulator to control the current of a connected LED string. The current is delivered from the supply through the LED string, the ILED pin, the integrated power MOSFET, the SRC pin, and the sensing resistor R_{SEN} connecting from the SRC pin to ground (Figure 1). The voltage of the sensing resistor is fed back to the LM3466 through the SEN pin, either by direct connection or through an extra resistor R_{SL} . The LM3466 regulates the voltage of the SEN pin (V_{SEN}) to a voltage set by its control block. If the sensing resistor of each LM3466 ($R_{SEN,k}$, $k = 1, 2, \dots, n$) is the same, the LED current of each active LED string is the same. If $R_{SEN,k}$ of any LM3466 is different from others, the corresponding LED current ($I_{LED,k}$) is different, while V_{SEN} of each LM3466 is still the same as others. The LED current of string k is

$$I_{LED,k} = \frac{I_S R_{TOTAL}}{R_{SEN,k}}$$

where I_S is the current of the supply, and

$$\frac{1}{R_{TOTAL}} = \sum_{i=1}^n \frac{1}{R_{SEN,i}}$$

In addition to determining the LED current by means of $R_{SEN,k}$, an external resistor $R_{SL,k}$ connecting between the SEN pin and $R_{SEN,k}$ can be used to fine tune the LED current for the purpose of color temperature adjustment or CRI enhancement. The SEN pin sources a constant bias current of 10.5 μ A such that a constant voltage drop on $R_{SL,k}$ reduces the LED current. Using an external resistor $R_{SL,k}$ affects the current of other LED strings. If $R_{SL,k}$ is added in the k -th LM3466, the corresponding LED current is

$$I_{LED,k} = \frac{I_S R_{TOTAL} - 10.5 \mu A R_{SL,k} R_{TOTAL}}{R_{SEN,k}} \left(\frac{1}{R_{TOTAL}} - \frac{1}{R_{SEN,k}} \right)$$

and the LED current of other strings is

$$I_{LED,i} = \frac{I_S R_{TOTAL} - 10.5 \mu A R_{SL,k} R_{TOTAL}}{R_{SEN,i}}$$

where $i = 1, 2, \dots, n$ except k . The LED current of LED string k is reduced, while the LED current of other channels increases. Figure 2 shows a typical example that the variation of LED current on varying $R_{SL,k}$.

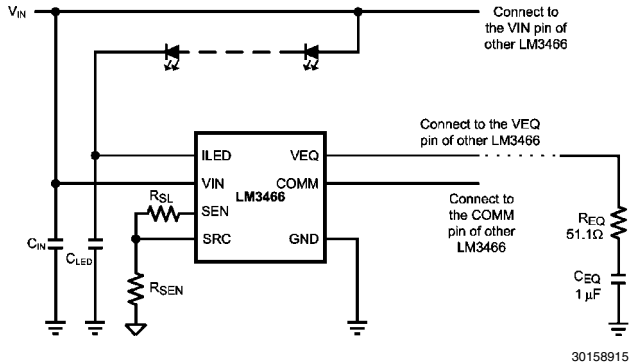

FIGURE 1. A Single LM3466 within a Lighting System

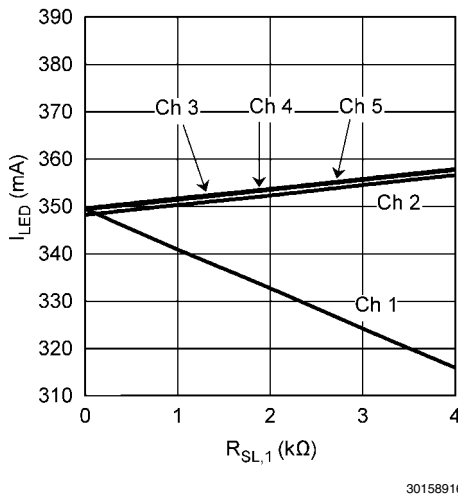

FIGURE 2. Variation of I_{LED} vs $R_{SL,k}$

LED String Disconnect and Reconnect

One major advantage of the LM3466 lighting system is that the overall brightness is maintained even if some LED strings open during operation. If an active LED string is suddenly disconnected, the LM3466 will automatically equalize the current delivered by the supply I_S (i.e. each string increases its LED current in this case) so as to keep I_S constant. However, the equalization takes place only after the LED string is confirmed inactive. Once the string is disconnected, V_{EQ} will go to a cycle (goes up and down). If the string is still disconnected for a period of 253 consecutive cycles, the string is confirmed

inactive. Consequently, the current of other LED strings increases to equalize I_S . The output power and the overall brightness of the lighting system are maintained.

If a new LED string connects to the system, such as if the disconnected LED string is reconnected again, a power reset is recommended to ensure proper operation. The forward voltage of the new LED string may be higher than the instantaneous V_{IN} , which corresponds to the forward voltage of the highest active LED string. A power reset ensures that V_{IN} goes to the peak voltage (a default characteristic of a constant current power supply) in order to start up the LED string with the highest forward voltage.

Communication Pin

The COMM pin serves as a communication link among all LM3466 in the lighting system. It also indicates the status of the device. The COMM pin is pulled low at startup. After startup, the COMM pin is high/low to indicate that the corresponding LED string is active/inactive.

For proper operation of a LM3466 system, the COMM pin of all LM3466 should be either shorted together or connected through a diode in parallel with a resistor. Figure 3 shows an optional circuit for the COMM pin to indicate whether each LED string is active by means of small signal LEDs. The COMM pin of each LM3466 is connected to an external test point COMM_ALL through the optional circuit.

The COMM pin is low if the LM3466 is under thermal protection.

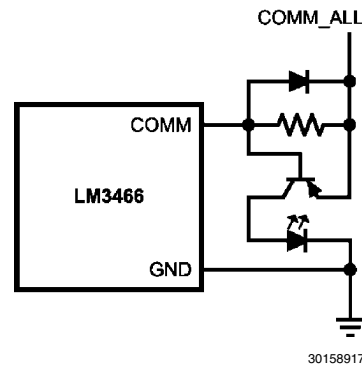
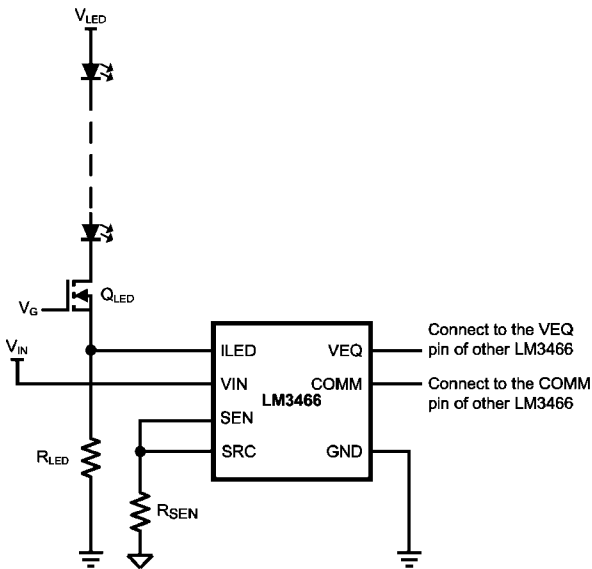

FIGURE 3. Optional Circuit for the COMM Pin

High Voltage Application

If the forward voltage of an LED string is higher than 70V, which is the maximum operating voltage of the LM3466, an external MOSFET circuit as shown in Figure 4 is recommended for each channel in order to protect the ILED pin from damaging by a high voltage owing to shorting LEDs (or even the whole LED string). To avoid the ILED pin damage from a high voltage generated by the leakage current, a resistor R_{LED} (1 MΩ is suggested) is placed between the ILED pin and ground. In addition, since V_{LED} is higher than 70V in this case, the VIN pin cannot be directly connected to V_{LED} . External power supplies for V_{IN} and V_G (to drive the external MOSFET) are required. Alternatively, Figure 5 shows a circuit for supplying V_{IN} and V_G (for all channels in the system).



30158927

FIGURE 4. External MOSFET circuit for high voltage applications

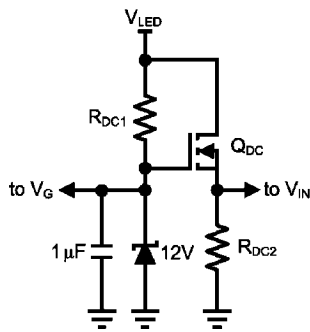

30158928

FIGURE 5. Power supply circuit for the external MOSFET circuit

Thermal Protection

Thermal protection is implemented by an internal thermal shutdown circuit, which activates at 150°C (typically) to disable the LM3466. In this case, the integrated power MOSFET turns off and the COMM pin is pulled low. Thermal protection helps prevent catastrophic failures from accidental device overheating. When the junction temperature of the LM3466 falls back below 140°C (typical hysteresis = 10°C), the LM3466 resumes normal operation.

Thermal Latch Off and Derating

If thermal protection cycles for 253 times consecutively, the LM3466 is latched off until power reset.

When fully turned on, the integrated power MOSFET of the LM3466 is capable of conducting a current of 1.5A below an ambient temperature of 100°C. At 125°C, the LM3466 can conduct a current of 1A without thermal shutdown with a PCB ground plane copper area of 60cm², 2 oz/Cu. Figure 6 shows a thermal derating curve for the minimum conducting current of a fully turned on LM3466 integrated power MOSFET with-

out thermal shutdown against an ambient temperature up to 125°C.

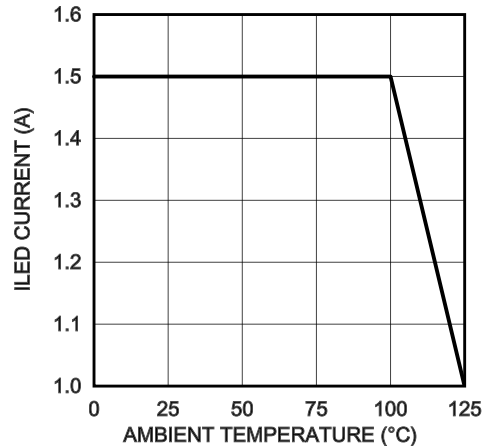

30158920

FIGURE 6. Thermal Derating Curve

Application Information

Consider a LM3466 lighting system which is powered by a 1.75A constant current power supply and consists of 5 LED strings with 14 LEDs per string. It is expected that the LED current of every LED string is 0.35A.

EXTERNAL COMPONENTS

R_{SEN}: To set the LED current of all 5 LED strings equal, the sensing resistors corresponding to all 5 LM3466 are equal. It is recommended that the nominal voltage of the SEN pin V_{SEN} should be around 0.3V. Therefore, R_{SEN} is selected to be 1Ω. As a result, V_{SEN} should be 0.35V if the LED current is 0.35A.

C_{LED}: If the cable connecting the LED string is long, the parasitic inductance of the cable may generate noise. If this happens, a high quality ceramic capacitor should be connected between the ILED pin and ground. In this example, a 100V, 1 μF ceramic capacitor is used.

C_{IN}: A high quality ceramic capacitor for decoupling should be connected from the VIN pin to ground. In this example, a 100V, 0.01 μF ceramic capacitor is used.

R_{EQ} and C_{EQ}: The VEQ pins of all LM3466 are shorted together and then connected to ground through R_{EQ} and C_{EQ}. Only one R_{EQ} and one C_{EQ} are required for each LM3466 lighting system. It is recommended that R_{EQ} be 51.1Ω and C_{EQ} be 1 μF.

PC BOARD LAYOUT

To minimize the effect of noise, the ground connections of the LM3466 and the sense resistor R_{SEN,k} should be closed. Good heat dissipation helps optimize the performance of the LM3466. The ground plane should be used to connect the exposed pad of the LM3466, which is internally connected to the LM3466 die substrate. The area of the ground plane should be extended as much as possible on the same copper layer above and below the LM3466. Using numerous vias beneath the exposed pad to dissipate heat of the LM3466 to another copper layer is also a good practice.

Additional Application Circuit

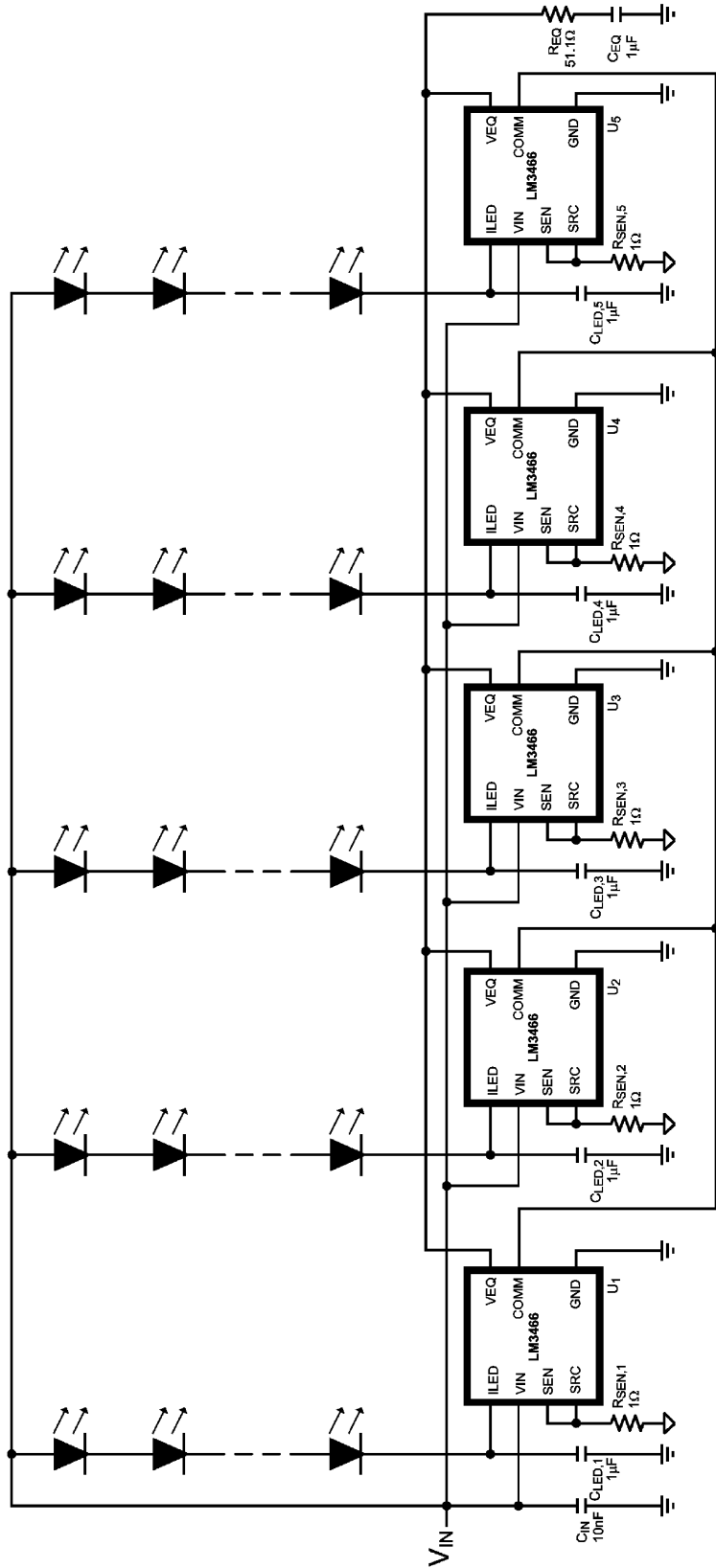

30158918

FIGURE 7. Application Circuit of a LM3466 Lighting System

Physical Dimensions inches (millimeters) unless otherwise noted

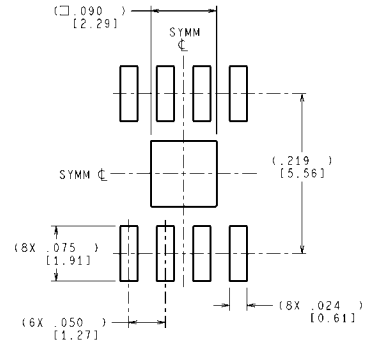
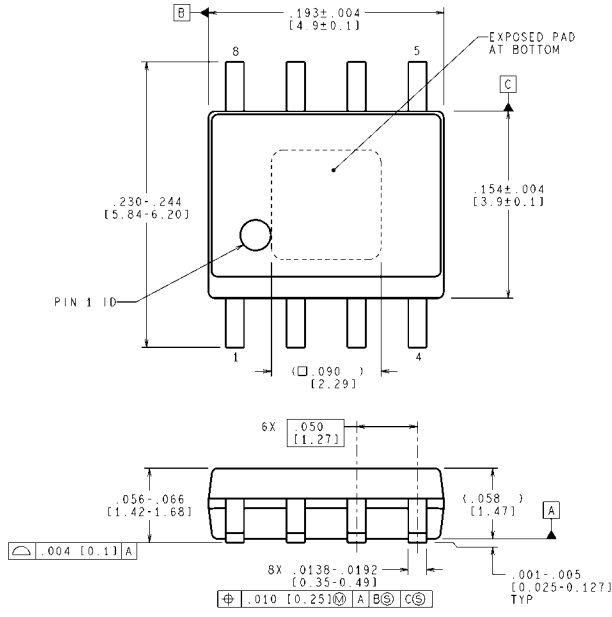

RECOMMENDED LAND PATTERN

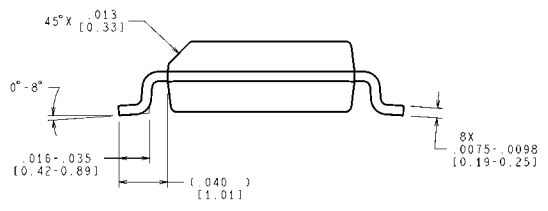

CONTROLLING DIMENSION IS INCH
 VALUES IN [] ARE MILLIMETERS
 DIMENSIONS IN () FOR REFERENCE ONLY

8-Lead Plastic ePSOP Package
NS Package Number MRA08A

MRA08A (Rev D)

Notes

Notes

IMPORTANT NOTICE

Texas Instruments Incorporated and its subsidiaries (TI) reserve the right to make corrections, modifications, enhancements, improvements, and other changes to its products and services at any time and to discontinue any product or service without notice. Customers should obtain the latest relevant information before placing orders and should verify that such information is current and complete. All products are sold subject to TI's terms and conditions of sale supplied at the time of order acknowledgment.

TI warrants performance of its hardware products to the specifications applicable at the time of sale in accordance with TI's standard warranty. Testing and other quality control techniques are used to the extent TI deems necessary to support this warranty. Except where mandated by government requirements, testing of all parameters of each product is not necessarily performed.

TI assumes no liability for applications assistance or customer product design. Customers are responsible for their products and applications using TI components. To minimize the risks associated with customer products and applications, customers should provide adequate design and operating safeguards.

TI does not warrant or represent that any license, either express or implied, is granted under any TI patent right, copyright, mask work right, or other TI intellectual property right relating to any combination, machine, or process in which TI products or services are used. Information published by TI regarding third-party products or services does not constitute a license from TI to use such products or services or a warranty or endorsement thereof. Use of such information may require a license from a third party under the patents or other intellectual property of the third party, or a license from TI under the patents or other intellectual property of TI.

Reproduction of TI information in TI data books or data sheets is permissible only if reproduction is without alteration and is accompanied by all associated warranties, conditions, limitations, and notices. Reproduction of this information with alteration is an unfair and deceptive business practice. TI is not responsible or liable for such altered documentation. Information of third parties may be subject to additional restrictions.

Resale of TI products or services with statements different from or beyond the parameters stated by TI for that product or service voids all express and any implied warranties for the associated TI product or service and is an unfair and deceptive business practice. TI is not responsible or liable for any such statements.

TI products are not authorized for use in safety-critical applications (such as life support) where a failure of the TI product would reasonably be expected to cause severe personal injury or death, unless officers of the parties have executed an agreement specifically governing such use. Buyers represent that they have all necessary expertise in the safety and regulatory ramifications of their applications, and acknowledge and agree that they are solely responsible for all legal, regulatory and safety-related requirements concerning their products and any use of TI products in such safety-critical applications, notwithstanding any applications-related information or support that may be provided by TI. Further, Buyers must fully indemnify TI and its representatives against any damages arising out of the use of TI products in such safety-critical applications.

TI products are neither designed nor intended for use in military/aerospace applications or environments unless the TI products are specifically designated by TI as military-grade or "enhanced plastic." Only products designated by TI as military-grade meet military specifications. Buyers acknowledge and agree that any such use of TI products which TI has not designated as military-grade is solely at the Buyer's risk, and that they are solely responsible for compliance with all legal and regulatory requirements in connection with such use.

TI products are neither designed nor intended for use in automotive applications or environments unless the specific TI products are designated by TI as compliant with ISO/TS 16949 requirements. Buyers acknowledge and agree that, if they use any non-designated products in automotive applications, TI will not be responsible for any failure to meet such requirements.

Following are URLs where you can obtain information on other Texas Instruments products and application solutions:

Products

Audio	www.ti.com/audio
Amplifiers	amplifier.ti.com
Data Converters	dataconverter.ti.com
DLP® Products	www.dlp.com
DSP	dsp.ti.com
Clocks and Timers	www.ti.com/clocks
Interface	interface.ti.com
Logic	logic.ti.com
Power Mgmt	power.ti.com
Microcontrollers	microcontroller.ti.com
RFID	www.ti-rfid.com
OMAP Mobile Processors	www.ti.com/omap
Wireless Connectivity	www.ti.com/wirelessconnectivity

Applications

Automotive and Transportation	www.ti.com/automotive
Communications and Telecom	www.ti.com/communications
Computers and Peripherals	www.ti.com/computers
Consumer Electronics	www.ti.com/consumer-apps
Energy and Lighting	www.ti.com/energy
Industrial	www.ti.com/industrial
Medical	www.ti.com/medical
Security	www.ti.com/security
Space, Avionics and Defense	www.ti.com/space-avionics-defense
Video and Imaging	www.ti.com/video

TI E2E Community Home Page

e2e.ti.com

Mailing Address: Texas Instruments, Post Office Box 655303, Dallas, Texas 75265
Copyright © 2012, Texas Instruments Incorporated