

FEATURES

- Industrial temperature range (-40°C to $+85^{\circ}\text{C}$)
- 3.3V power supply
- SONET/SDH/ATM compatible
- Clock and data recovery for 125Mbps/155Mbps NRZ data stream
- Two on-chip PLLs: one for clock generation and another for clock recovery
- Selectable reference frequencies
- Differential PECL high-speed serial I/O
- Line receiver input: no external buffering needed
- Link fault indication
- 100k ECL compatible I/O
- Complies with Bellcore, ITU/CCITT and ANSI specifications for OC-3 applications
- Available in 32-pin EPAD-TQFP

DESCRIPTION

The SY69753L is a complete Clock Recovery and Data Retiming integrated circuit for OC-3/STS-3 applications at 155Mbps NRZ. The device is ideally suited for SONET/SDH/ATM applications and other high-speed data transmission systems.

Clock recovery and data retiming is performed by synchronizing the on-chip VCO directly to the incoming data stream. The VCO center frequency is controlled by the reference clock frequency and the selected divide ratio. On-chip clock generation is performed through the use of a frequency multiplier PLL with a byte rate source as reference.

The SY69753L also includes a link fault detection circuit.

Data sheets and support documentation can be found on Micrel's web site at www.micrel.com.

APPLICATIONS

- Ethernet media converter
- SONET/SDH/ATM OC-3
- Proprietary architectures at 135Mbps to 180Mbps

BLOCK DIAGRAM

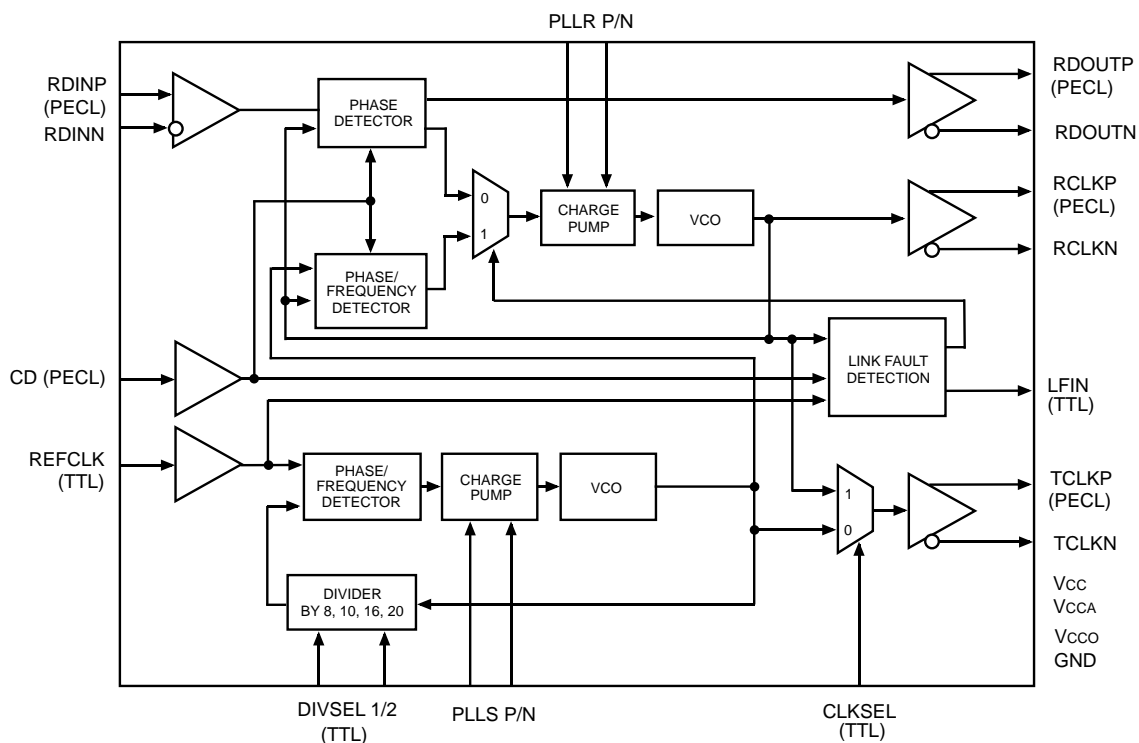

PACKAGE/ORDERING INFORMATION

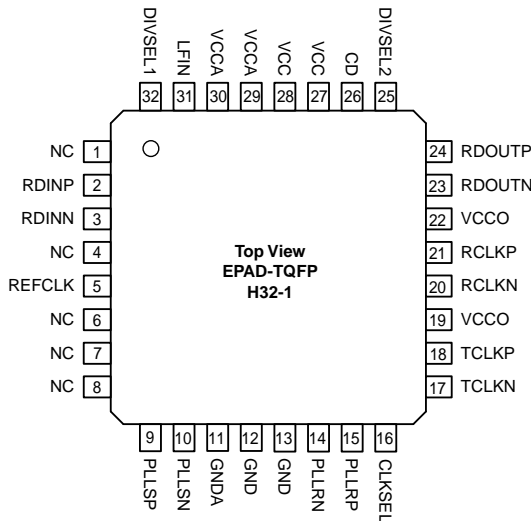

Ordering Information

| Part Number | Package Type | Operating Range | Package Marking |
|-------------|--------------|-----------------|-----------------|
| SY69753LHI | H32-1 | Industrial | SY69753LHI |
| SY69753LHI* | H32-1 | Industrial | SY69753LHI |

*Tape and Reel

PIN DESCRIPTIONS

INPUTS

RDINP, RDINN [Serial Data Input] Differential PECL

These built-in line receiver inputs are connected to the differential receive serial data stream. An internal receive PLL recovers the embedded clock (RCLK) and data (RDOU) information.

REFCLK [Reference Clock] TTL Input

This input is used as the reference for the internal frequency synthesizer and the "training" frequency for the receiver PLL to keep it centered in the absence of data coming in on the RDIN inputs.

CD [Carrier Detect] PECL Input

This input controls the recovery function of the Receive PLL and can be driven by the carrier detect output of optical modules or from external transition detection circuitry. When this input is HIGH the input data stream (RDIN) is recovered normally by the Receive PLL. When this input is LOW the data on the inputs RDIN will be internally forced to a constant LOW, the data outputs RDOU will remain LOW, the Link Fault Indicator output LFIN forced LOW and the clock recovery PLL forced to look onto the clock frequency generated from REFCLK.

DIVSEL1, DIVSEL2 [Divider Select] TTL Inputs

These inputs select the ratio between the output clock frequency (RCLK/TCLK) and the REFCLK input frequency as shown in the "Reference Frequency Selection" Table.

CLKSEL [Clock Select] TTL Inputs

This input is used to select either the recovered clock of the receiver PLL (CLKSEL = HIGH) or the clock of the frequency synthesizer (CLKSEL = LOW) to the TCLK outputs.

OUTPUTS

LFIN [Link Fault Indicator] TTL Output

This output indicates the status of the input data stream RDIN. Active HIGH signal is indicating when the internal clock recovery PLL has locked onto the incoming data stream. LFIN will go HIGH if CD is HIGH and RDIN is within the frequency range of the Receive PLL (1000ppm). LFIN is an asynchronous output.

RDOUTP, RDOUTN [Receive Data Output] Differential PECL

These ECL 100K outputs represent the recovered data from the input data stream (RDIN). This recovered data is specified against the rising edge of RCLK.

RCLKP, RCLKN [Clock Output] Differential PECL

These ECL 100K outputs represent the recovered clock used to sample the recovered data (RDOU).

TCLKP, TCLKN [Clock Output] Differential PECL

These ECL 100K outputs represent either the recovered clock (CLKSEL = HIGH) used to sample the recovered data (RDOU) or the transmit clock of the frequency synthesizer (CLKSEL = LOW).

PLLSP, PLLSN [Clock Synthesis PLL Loop Filter]

External loop filter pins for the clock synthesis PLL.

PLLRP, PLLRN [Clock Recovery PLL Loop Filter]

External loop filter pins for the receiver PLL.

POWER & GROUND

VCC Supply Voltage(1)

VCCA Analog Supply Voltage(1)

VCCO Output Supply Voltage(1)

GND Ground

N/C No Connect

NOTE:

1. VCC, VCCA, VCCO must be the same value.

Absolute Maximum Ratings(Note 1)

Supply Voltage (V_{CC}) -0.5V to +5.0V
 Input Voltage (V_{IN}) -0.5V to V_{CC}
 Output Current (I_{OUT})
 Continuous 50mA
 Surge 100mA
 Storage Temperature (T_S) -65°C to +150°C

Operating Ratings(Note 2)

Supply Voltage (V_{CC}) +3.15V to +3.45V
 Ambient Temperature (T_A) -40°C to +85°C
 Junction Temperature (T_J) +125°C
 Package Thermal Resistance, **Note 3**
 EPAD-TQFP (θ_{JA})
 Still-Air 28°C/W
 500lfpm 20°C/W
 EPAD-TQFP (θ_{JC}) 4°C/W

DC ELECTRICAL CHARACTERISTICS

$T_A = -40^\circ\text{C to } +85^\circ\text{C}$

| Symbol | Parameter | Condition | Min | Typ | Max | Units |
|----------|----------------------|-----------|------|-----|------|-------|
| V_{CC} | Power Supply Voltage | | 3.15 | 3.3 | 3.45 | V |
| I_{CC} | Power Supply Current | | — | 170 | 230 | mA |

PECL 100K DC ELECTRICAL CHARACTERISTICS

$V_{CC} = V_{CCO} = V_{CCA} = 3.3V \pm 5\%$; $T_A = -40^\circ\text{C to } +85^\circ\text{C}$

| Symbol | Parameter | Condition | Min | Typ | Max | Units |
|----------|---------------------|--------------------------------|------------------|-----|------------------|---------------|
| V_{IH} | Input HIGH Voltage | | $V_{CC} - 1.165$ | — | $V_{CC} - 0.880$ | V |
| V_{IL} | Input LOW Voltage | | $V_{CC} - 1.810$ | — | $V_{CC} - 1.475$ | V |
| I_{IL} | Input LOW Current | $V_{IN} = V_{IL}(\text{Min.})$ | 0.5 | — | — | μA |
| V_{OH} | Output HIGH Voltage | 50Ω to $V_{CC} - 2V$ | $V_{CC} - 1.075$ | — | $V_{CC} - 0.830$ | V |
| V_{OL} | Output LOW Voltage | 50Ω to $V_{CC} - 2V$ | $V_{CC} - 1.860$ | — | $V_{CC} - 1.570$ | V |

TTL DC ELECTRICAL CHARACTERISTICS

$V_{CC} = V_{CCO} = V_{CCA} = 3.3V \pm 5\%$; $T_A = -40^\circ\text{C to } +85^\circ\text{C}$

| Symbol | Parameter | Condition | Min | Typ | Max | Units |
|----------|------------------------------|--|-----------|--------|-----------|--------------------------------|
| V_{IH} | Input HIGH Voltage | | 2.0 | — | V_{CC} | V |
| V_{IL} | Input LOW Voltage | | — | — | 0.8 | V |
| I_{IH} | Input HIGH Current | $V_{IN} = 2.7V, V_{CC} = \text{Max.}$ $V_{IN} = V_{CC}, V_{CC} = \text{Max.}$ | -125 — | — — | — +100 | μA μA |
| I_{IL} | Input LOW Current | $V_{IN} = 0.5V, V_{CC} = \text{Max.}$ | -300 | — | — | μA |
| V_{OH} | Output HIGH Voltage | $I_{OH} = -0.4mA$ | 2.0 | — | — | V |
| V_{OL} | Output LOW Voltage | $I_{OL} = 4mA$ | — | — | 0.5 | V |
| I_{OS} | Output Short Circuit Current | $V_{OUT} = 0V$ (maximum 1sec) | -15 | — | -100 | mA |

Note 1. Permanent device damage may occur if ABSOLUTE MAXIMUM RATINGS are exceeded. This is a stress rating only and functional operation is not implied at conditions other than those detailed in the operational sections of this data sheet. Exposure to ABSOLUTE MAXIMUM RATING conditions for extended periods may affect device reliability.

Note 2. The data sheet limits are not guaranteed if the device is operated beyond the operating ratings.

Note 3. Numbers valid with proper thermal design of PCB and exposed pad soldered to island on PCB. Refer to Figure on page 9.

AC ELECTRICAL CHARACTERISTICS

$V_{CC} = V_{CCO} = V_{CCA} = 3.3V \pm 5\%$; $T_A = -40^\circ\text{C}$ to $+85^\circ\text{C}$

| Symbol | Parameter | Condition | Min | Typ | Max | Units |
|------------------|--|-----------------------------|--------------------------|-----|------|---------------|
| f_{VCO} | VCO Center Frequency | | 800 | — | 1100 | MHz |
| Δf_{VCO} | VCO Center Frequency Tolerance | Nominal | — | 5 | — | % |
| t_{ACQ} | Acquisition Lock Time | | — | — | 15 | μs |
| t_{CPWH} | REFCLK Pulse Width HIGH | | 4 | — | — | ns |
| t_{CPWL} | REFCLK Pulse Width LOW | | 4 | — | — | ns |
| t_{DV} | Data Valid | | $1/(2 * f_{RCLK}) - 200$ | — | — | ps |
| t_{DH} | Data Hold | | $1/(2 * f_{RCLK}) - 200$ | — | — | ps |
| t_{ir} | REFCLK Input Rise Time | | — | 0.5 | 2 | ns |
| t_{ODC} | Output Duty Cycle (RCLK/TCLK) | | 45 | — | 55 | % of UI |
| t_{rskew} | Recovered Clock Skew | | -200 | — | +200 | ps |
| t_r, t_f | ECL Output Rise/Fall Time (20% to 80%) | 50Ω to $V_{CC} - 2V$ | 100 | — | 500 | ps |

FUNCTIONAL DESCRIPTION AND CHARACTERISTICS

Clock Recovery

Clock Recovery, as shown in the block diagram generates a clock that is at the same frequency as the incoming data bit rate at the Serial Data input. The clock is phase aligned by a PLL so that it samples the data in the center of the data eye pattern.

The phase relationship between the edge transitions of the data and those of the generated clock are compared by a phase/frequency detector. Output pulses from the detector indicate the required direction of phase correction. These pulses are smoothed by an integral loop filter. The output of the loop filter controls the frequency of the Voltage Controlled Oscillator (VCO), which generates the recovered clock.

Frequency stability without incoming data is guaranteed by an alternate reference input (REFCLK) that the PLL locks onto when data is lost. If the Frequency of the incoming signal varies by greater than approximately 1000ppm with respect to the synthesizer frequency, the PLL will be declared out of lock, and the PLL will lock to the reference clock.

The loop filter transfer function is optimized to enable the PLL to track the jitter, yet tolerate the minimum transition density expected in a received SONET data signal. This transfer function yields a 30µs data stream of continuous 1's or 0's for random incoming NRZ data.

The total loop dynamics of the clock recovery PLL provides jitter tolerance which is better than the specified tolerance in GR-253-CORE.

Lock Detect

The SY69753L contains a link fault indication circuit which monitors the integrity of the serial data inputs. If the received serial data fails the frequency test, the PLL will be forced to lock to the local reference clock. This will maintain the correct frequency of the recovered clock output under loss of signal or loss of lock conditions. If the recovered clock frequency deviates from the local reference clock frequency by more than approximately 1000ppm, the PLL will be declared out of lock. The lock detect circuit will poll the input data stream in an attempt to reacquire lock to data. If the recovered clock frequency is determined to be within approximately 1000ppm, the PLL will be declared in lock and the lock detect output will go active.

Performance

The SY69753L PLL complies with the jitter specifications proposed for SONET/SDH equipment defined by the Bellcore Specifications: GR-253-CORE, Issue 2, December 1995 and ITU-T Recommendations: G.958 document, when used with differential inputs and outputs.

Input Jitter Tolerance

Input jitter tolerance is defined as the peak-to-peak amplitude of sinusoidal jitter applied on the input signal that causes an equivalent 1dB optical/electrical power penalty. SONET input jitter tolerance requirement condition is the input jitter amplitude which causes an equivalent of 1dB power penalty.

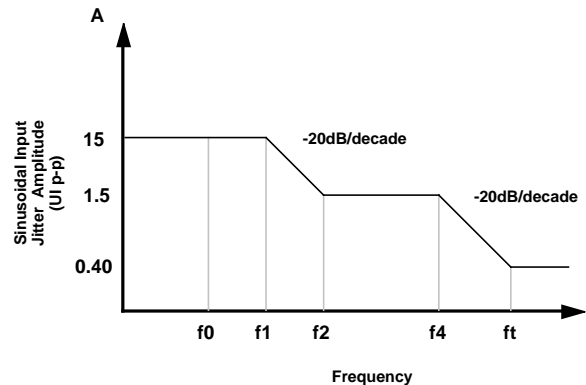

| OC/STS-N Level | f0 (Hz) | f1 (Hz) | f2 (Hz) | f3 (kHz) | ft (kHz) |
|----------------|---------|---------|---------|----------|----------|
| 3 | 10 | 30 | 300 | 6.5 | 65 |

Figure 1. Input Jitter Tolerance

Jitter Transfer

Jitter transfer function is defined as the ratio of jitter on the output OC-N/STS-N signal to the jitter applied on the input OC-N/STS-N signal versus frequency. Jitter transfer requirements are shown in Figure 2.

Jitter Generation

The jitter of the serial clock and serial data outputs shall not exceed .01 U.I. rms when a serial data input with no jitter is presented to the serial data inputs.

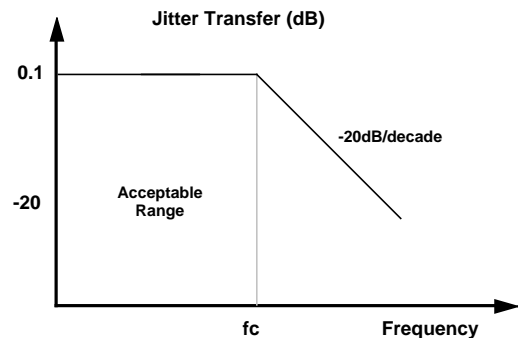

| OC/STS-N Level | fc (kHz) | P (dB) |
|----------------|----------|--------|
| 3 | 500 | 0.1 |

Figure 2. Jitter Transfer

LOOP FILTER COMPONENTS⁽¹⁾

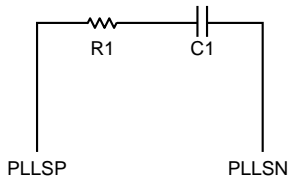

R1 = 80Ω
 C1 = 1.5μF (X7R Dielectric)

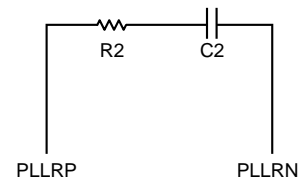

R2 = 50Ω
 C2 = 1.0μF (X7R Dielectric)

NOTE:

1. Suggested Values. Values may vary for different applications.

REFERENCE FREQUENCY SELECTION

| DIVSEL1 | DIVSEL2 | f_{RCLK}/f_{REFCLK} |
|---------|---------|-----------------------|
| 0 | 0 | 8 |
| 0 | 1 | 10 |
| 1 | 0 | 16 |
| 1 | 1 | 20 |

TIMING WAVEFORMS

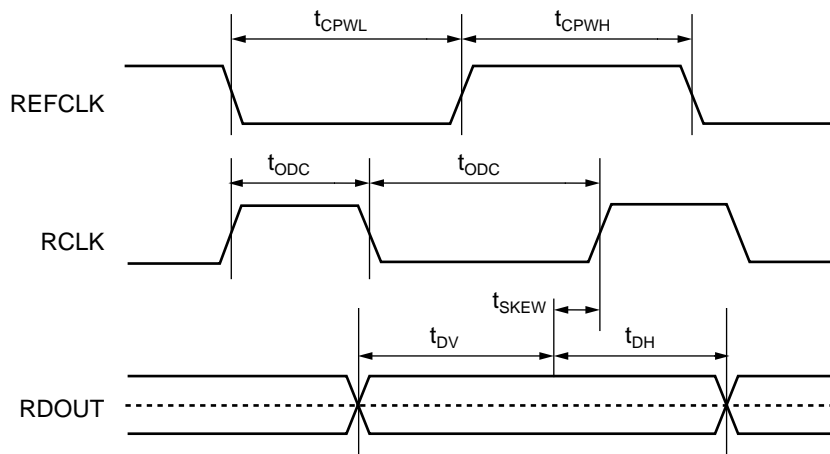

APPLICATION EXAMPLE

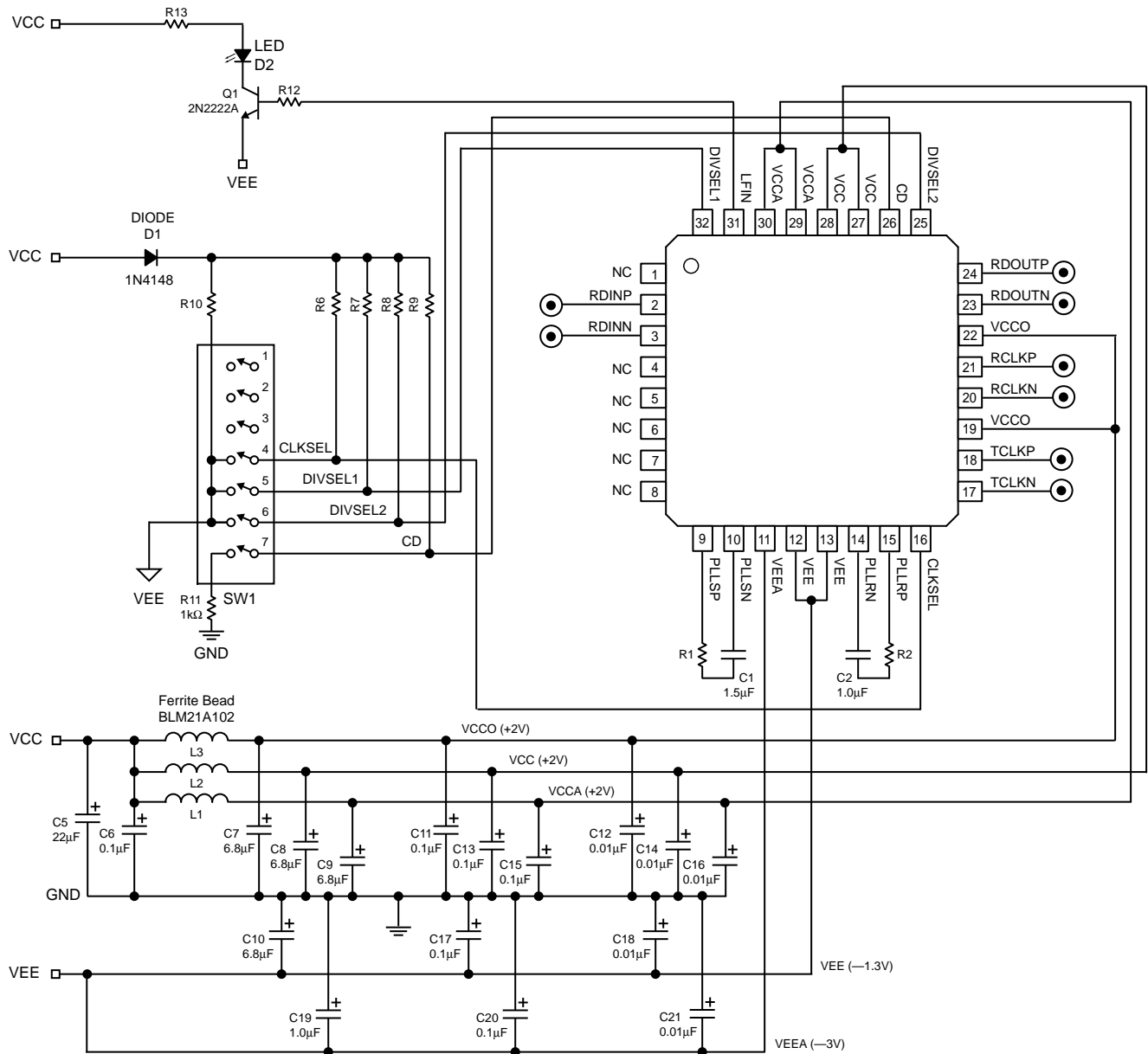

Note:
C3, C4 are optional

| |
|----------------------|
| C1 = 1.5μF |
| C2 = 1.0μF |
| R1 = 80Ω |
| R2 = 50Ω |
| R3 through R10 = 5kΩ |
| R12 = 12kΩ |
| R13 = 130Ω |

BILL OF MATERIALS

| Item | Part Number | Manufacturer | Description | Qty. |
|--|-----------------|-----------------------|---|------|
| C1 | ECU-V1H104KBW | Panasonic | 1.5 μ F Ceramic Capacitor, Size 1206 X7R Dielectric, Loop Filter, Critical | 1 |
| C2 | ECU-V1H104KBW | Panasonic | 1.0 μ F Ceramic Capacitor, Size 1206 X7R Dielectric, Loop Filter, Critical | 1 |
| C3, C4 | ECU-V1H104KBW | Panasonic | 0.47 μ F Ceramic Capacitor, Size 1206 X7R Dielectric, Loop Filter, Optional | 2 |
| C5 | ECS-T1ED226R | Panasonic | 22 μ F Tantalum Electrolytic Capacitor, Size D | 1 |
| C6 | ECU-V1H104KBW | Panasonic | 0.1 μ F Ceramic Capacitor, Size 1206 X7R Dielectric, Power Supply Decoupling | 1 |
| C7, C8, C9, C10 | ECS-T1EC685R | Panasonic | 6.8 μ F Tantalum Electrolytic Capacitor, Size C | 4 |
| C19 | ECJ-3YB1E105K | Panasonic | 1.0 μ F Ceramic Capacitor, Size 1206 X7R Dielectric, VEEA Decoupling | 1 |
| C11, C13 | ECU-V1H104KBW | Panasonic | 0.1 μ F Ceramic Capacitor, Size 1206 X7R Dielectric, VCCO/VCC Decoupling | 1 |
| C15, C17 | ECU-V1H104KBW | Panasonic | 0.1 μ F Ceramic Capacitor, Size 1206 X7R Dielectric, VCCA/VEEA Decoupling | 1 |
| C20 | ECU-V1H104KBW | Panasonic | 0.1 μ F Ceramic Capacitor, Size 1206 X7R Dielectric, VEEA Decoupling | 1 |
| C12, C14 | ECU-V1H103KBW | Panasonic | 0.01 μ F Ceramic Capacitor, Size 1206 X7R Dielectric, VCCO/VCC Decoupling | 1 |
| C16, C18 | ECU-V1H103KBW | Panasonic | 0.01 μ F Ceramic Capacitor, Size 1206 X7R Dielectric, VCCA/VEEA Decoupling | 1 |
| C21 | ECU-V1H103KBW | Panasonic | 0.01 μ F Ceramic Capacitor, Size 1206 X7R Dielectric, VEEA Decoupling | 1 |
| D1 | 1N4148 | | Diode | 1 |
| D2 | P300-ND/P301-ND | Panasonic | T-1 3/4 Red LED | 1 |
| J1, J2, J3, J4, J5 J6, J7, J8, J9, J10, J11, J12 | 142-0701-851 | Johnson Components | Gold Plated, Jack, SMA, PCB Mount | 12 |
| L1, L2, L3 | BLM21A102F | Murata | Ferrite Beads, Power Noise Suppression | 3 |
| Q1 | NTE123A | NTE | 2N2222A Buffer/Driver Transistor, NPN | 1 |
| R1 | | | 80 Ω Resistor, 2%, Size 1206 Loop Filter Component, Critical | 1 |
| R2 | | | 50 Ω Resistor, 2%, Size 1206 Loop Filter Component, Critical | 1 |
| R3, R4, R5, R6 R7, R8, R9, R10 | | | 5k Ω Pullup Resistors, 2%, Size 1206 | 8 |
| R11 | | | 1k Ω Pulldown Resistor, 2%, Size 1206 | 1 |
| R12 | | | 12k Ω Resistor, 2%, Size 1206 | 1 |
| R13 | | | 130 Ω Pullup Resistor, 2%, Size 1206 | 1 |
| SW1 | 206-7 | CTS | SPST, Gold Finish, Sealed Dip Switch | 1 |

32 LEAD EPAD-TQFP (DIE UP) (H32-1)

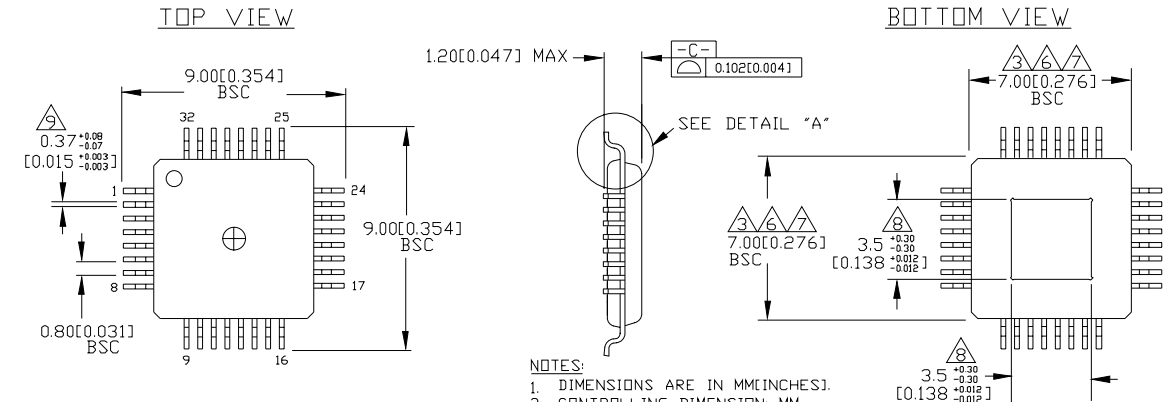

- NOTES:**
1. DIMENSIONS ARE IN MILLIMETERS.
 2. CONTROLLING DIMENSION: MM.
 3. DIMENSION DOES NOT INCLUDE MOLD FLASH OR PROTRUSIONS, EITHER OF WHICH SHALL NOT EXCEED 0.254 [0.010].
 4. LEAD DIMENSION DOES NOT INCLUDE DAMBAR PROTRUSION.
 5. MAXIMUM AND MINIMUM SPECIFICATIONS ARE INDICATED AS FOLLOWS: MAX/MIN. THESE DIMENSIONS TO BE DETERMINED AT DATUM PLANE [H].
 6. PACKAGE TOP DIMENSIONS ARE SMALLER THAN BOTTOM DIMENSIONS AND TOP OF PACKAGE WILL NOT OVERHANG BOTTOM OF PACKAGE.
 7. EXPOSED PAD SHALL BE COPLANAR WITH PACKAGE BOTTOM WITHIN 0.05mm. EXPOSED PAD: Cu WITH Sn/Pb PLATING
 8. DIMENSION INCLUDES LEAD FINISH.

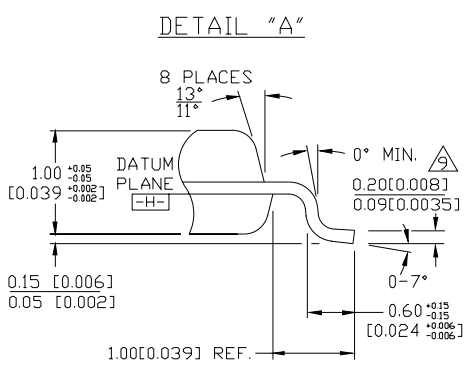

Rev. 01

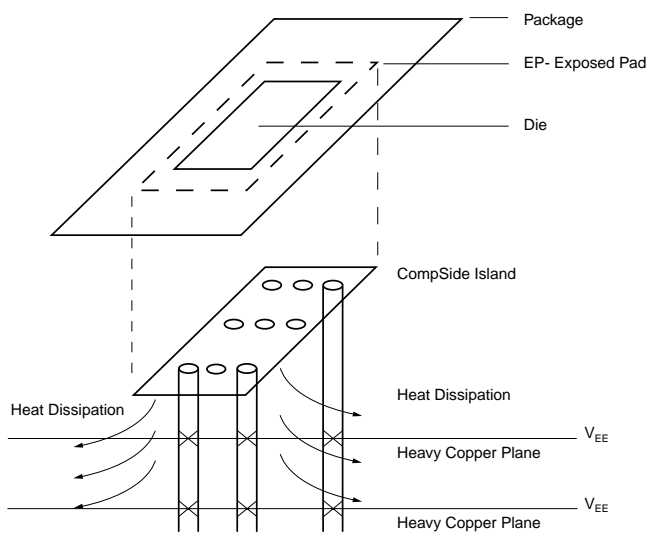

PCB Thermal Consideration for 32-Pin EPAD-TQFP Package

MICREL, INC. 1849 FORTUNE DRIVE SAN JOSE, CA 95131 USA

TEL + 1 (408) 944-0800 FAX + 1 (408) 944-0970 WEB <http://www.micrel.com>

The information furnished by Micrel in this datasheet is believed to be accurate and reliable. However, no responsibility is assumed by Micrel for its use. Micrel reserves the right to change circuitry and specifications at any time without notification to the customer.

Micrel Products are not designed or authorized for use as components in life support appliances, devices or systems where malfunction of a product can reasonably be expected to result in personal injury. Life support devices or systems are devices or systems that (a) are intended for surgical implant into the body or (b) support or sustain life, and whose failure to perform can be reasonably expected to result in a significant injury to the user. A Purchaser's use or sale of Micrel Products for use in life support appliances, devices or systems is at Purchaser's own risk and Purchaser agrees to fully indemnify Micrel for any damages resulting from such use or sale.