



MC13821



Package Information
Plastic Package
Case 1345
(QFN-12)

MC13821

Low Noise Amplifier with Bypass Switch

Ordering Information

Device	Device Marking or Operating Temperature Range	Package
MC13821	821	QFN-12

1 Introduction

The MC13821 is a high gain LNA with extremely low noise figure, designed for cellular, GPS and ISM band applications. An integrated bypass switch is included to preserve input intercept performance. The input and output match are external to allow maximum design flexibility. The MC13821 is fabricated using Freescale's advanced RF BiCMOS process using the SiGe:C option and is packaged in the QFN-12 leadless package.

Contents:

1 Introduction	1
2 Electrical Specifications	3
3 Application Information	10
4 Printed Circuit Board	28
5 Scattering Parameters	32
6 Packaging	41
7 Reference Documentation	42
8 Revision History	42

1.1 Features

- RF Input Frequency: 1000 MHz to 2.4 GHz
- Gain: 16.4 dB (typ) at 1960 MHz and 15.7 dB (typ) at 2140 MHz
- Output 3rd Order Intercept Point (OIP3): 17.4 dBm (typ) at 1960 MHz and 19.7 dBm (typ) at 2140 MHz
- Noise Figure (NF): 1.25 dB (typ) at 1960 MHz and 1.3 dB (typ) at 2140 MHz
- 1dB Compression Point (P1dB): -6 dBm (typ) at 1960 MHz and -5 dBm (typ) at 2140 MHz

This document contains information on a new product. Specifications and information herein are subject to change without notice.

© Freescale Semiconductor, Inc., 2005–2008. All rights reserved.



Introduction

- Freescale's IP3 Boost Circuitry
- Bypass Mode Included for Improved Intercept Point Performance
- Total Supply Current:
2.8 mA @ 2.7 Vdc
10 μ A (typ) in Bypass Mode
- Bias Stabilized for Device and Temperature Variations
- QFN-12 Leadless Package with Low Parasitics
- SiGe Technology Ensures Lowest Possible Noise Figure

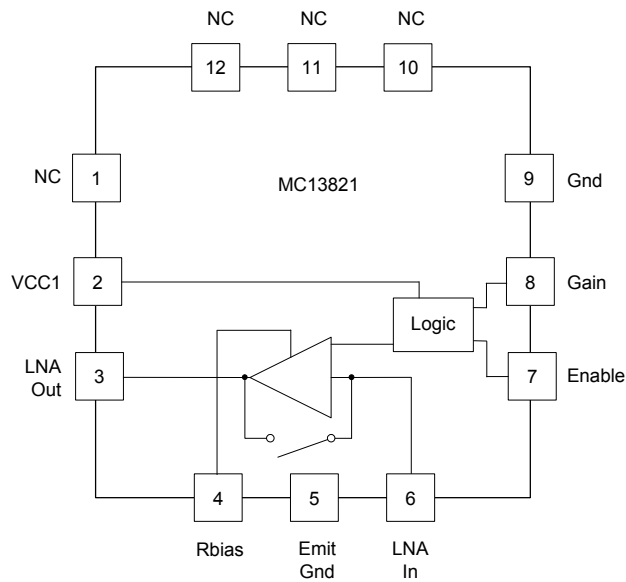

Figure 1. Simplified Block Diagram

2 Electrical Specifications

Table 1. Maximum Ratings

Ratings	Symbol	Minimum	Typical	Maximum	Unit
Supply Voltage	V_{CC}	2.7	2.75	3.3	V
Storage Temperature Range	T_{stg}	-65	25	150	°C
Operating Ambient Temperature Range	T_A	-30	25	85	°C
RF Input Power	P_{rf}	—	-30	10	dBm
Power Dissipation	P_{dis}	—	—	100	mW
Thermal Resistance, Junction to Case	$R_{\theta JC}$	24	24	24	C/W
Thermal Resistance, Junction to Ambient, 4 Layer Board	$R_{\theta JA}$	90	90	90	C/W

- NOTES:** 1. Maximum Ratings are those values beyond which damage to the device may occur. Functional operation should be restricted to the limits in the Recommended Operating Conditions and Electrical Characteristics tables.
 2. ESD (electrostatic discharge) immunity meets Human Body Model (HBM) ≤ 200 V, Charge Device Model (CDM) ≤ 450 V, and Machine Model (MM) ≤ 50 V. Additional ESD data available upon request.

Table 2. Recommended Operating Conditions

Characteristic	Symbol	Minimum	Typical	Maximum	Unit
RF Frequency range	f_{RF}	1000	—	2400	MHz
Supply Voltage	V_{CC}	2.7	2.75	3	V
Logic Voltage	—	—	—	—	V
Input High Voltage	—	1.25	1.8	V_{CC}	
Input Low Voltage	—	0	0	0.8	

Table 3. Electrical Characteristics

($V_{CC} = 2.75$ V, $T_A = 25^\circ\text{C}$, unless otherwise noted.)

Characteristic	Symbol	Minimum	Typical	Maximum	Unit
Insertion Gain R1=1.2 k Ω , Freq=1.960 GHz R1=1.2 k Ω , Freq=2.14 GHz R1=2 k Ω , Freq=1.960 GHz R1=2 k Ω , Freq=2.14 GHz	$ S_{21} ^2$	15.0 14.5 13.3 13	16.0 15.6 14.3 14.2	17.0 16.5 15.3 15.2	dB
Maximum Stable Gain and/or Maximum Available Gain ¹ R1=1.2 k Ω , Freq=1.960 GHz R1=1.2 k Ω , Freq=2.14 GHz R1=2 k Ω , Freq=1.960 GHz R1=2 k Ω , Freq=2.14 GHz	MSG, MAG	20.0 19.5 19.5 19.5	21.0 20.5 20.5 19.8	22.0 21.5 21.5 21.0	dB
Minimum Noise Figure R1=1.2 k Ω , Freq=1.960 GHz R1=1.2 k Ω , Freq=2.14 GHz R1=2 k Ω , Freq=1.960 GHz R1=2 k Ω , Freq=2.14 GHz	NFmin	0.9 0.9 0.9 0.9	1.01 0.96 1.01 0.96	1.1 1.05 1.1 1.05	dB

Table 3. Electrical Characteristics (continued)

(V_{CC} = 2.75 V, T_A = 25°C, unless otherwise noted.)

Characteristic	Symbol	Minimum	Typical	Maximum	Unit
Associated Gain at Minimum Noise Figure	G _{nf}				dB
R1=1.2 kΩ, Freq=1.960 GHz		19.8	20.8	21.8	
R1=1.2 kΩ, Freq=2.14 GHz		19	19.8	20.8	
R1=2 kΩ, Freq=1.960 GHz		19.6	20.5	21.5	
R1=2 kΩ, Freq=2.14 GHz		19	19.8	20.8	

¹ Maximum Available Gain and Maximum Stable Gain are defined by the K factor as follows:

$$MAG = \left| \frac{S_{21}}{S_{12}} (K \pm \sqrt{K^2 - 1}) \right|, \text{ if } K > 1, \text{ MSG} = \left| \frac{S_{21}}{S_{12}} \right|, \text{ if } K < 1$$

Table 4. Electrical Characteristics Measured in Frequency Specific Tuned Circuits

(V_{CC} = 2.75 V, T_A = 25°C, R_{bias} = 2 kΩ, unless otherwise noted.)

Characteristic	Symbol	Minimum	Typical	Maximum	Unit
1575 MHz (Refer to Figure 9)					
Frequency	f	—	1575	—	MHz
Active Gain	G	16	17.7	18.7	dB
Active Noise Figure	NF	1.0	1.25	1.45	dB
Active Input Third Order Intercept Point	IIP3	-1.0	0.5	1.5	dBm
Active Input 1dB Compression Point	P _{1dB}	-11	-10	-9	dBm
Active Current @ 2.75 V	I _{CC}	2.3	2.8	3.3	mA
Bypass Gain	G	-6.0	-4.1	-3.1	dB
Bypass Noise Figure	NF	3.9	4.8	6	dB
Bypass Input Third Order Intercept Point	IIP3	24	26	27	dBm
Bypass Current		2	4	20	μA
1960 MHz (Refer to Figure 10)					
Frequency	f	—	1960	—	MHz
Active Gain	G	15	16.4	17.4	dB
Active Noise Figure	NF	1.0	1.25	1.45	dB
Active Input Third Order Intercept Point	IIP3	-0.5	1	2	dBm
Active Input 1dB Compression Point	P _{1dB}	-7	-6	-5	dBm
Active Current @ 2.75 V	I _{CC}	2.3	2.8	3.3	mA
Bypass Gain	G	-6	-3.9	-3	dB
Bypass Noise Figure	NF	3.9	4.7	6	dB
Bypass Input Third Order Intercept Point	IIP3	23	25	26	dBm
Bypass Current		2	4	20	μA

Table 4. Electrical Characteristics Measured in Frequency Specific Tuned Circuits (continued) $(V_{CC} = 2.75 \text{ V}, T_A = 25^\circ\text{C}, R_{bias} = 2 \text{ k}\Omega, \text{ unless otherwise noted.})$

Characteristic	Symbol	Minimum	Typical	Maximum	Unit
1960 MHz (R1 = 1.3 kΩ, R2 = 68 Ω, C1 = 15 pF, C2 = 1.2 pF, L1 = 5.6 nH) (Refer to Figure 10)					
Frequency	f	—	1960	—	MHz
Active Gain	G	10.5	11.5	13	dB
Active Noise Figure	NF	1.1	1.3	1.9	dB
Active Input Third Order Intercept Point	IIP3	-2	0	1	dBm
Active Input 1dB Compression Point	P _{1dB}	-15	-10	—	dBm
Active Current @ 2.75 V	I _{CC}	3.6	4.5	5.5	mA
Bypass Gain	G	-6.5	-3.5	-3	dB
Bypass Noise Figure	NF	3.8	4.7	6	dB
Bypass Input Third Order Intercept Point	IIP3	20	21	22	dBm
Bypass Current		2	4	20	μ A
1960 MHz (R1 = 1.8 kΩ, R2 = 330 Ω, C1 = 8 pF, C2 = 1.2 pF, L1 = 4.7 nH) (Refer to Figure 10)					
Frequency	f	—	1960	—	MHz
Active Gain	G	13.8	14.8	16	dB
Active Noise Figure	NF	1.1	1.3	1.9	dB
Active Input Third Order Intercept Point	IIP3	-2	0	1	dBm
Active Input 1dB Compression Point	P _{1dB}	-10	-5	-4	dBm
Active Current @ 2.75 V	I _{CC}	2.3	2.8	5.5	mA
Bypass Gain	G	-6.5	-3.5	-3	dB
Bypass Noise Figure	NF	3.8	4.7	6	dB
Bypass Input Third Order Intercept Point	IIP3	16	18	18.5	dBm
Bypass Current		2	4	20	μ A
2140 MHz (Refer to Figure 11)					
Frequency	f	—	2140	—	MHz
Active Gain	G	14.7	15.7	17.5	dB
Active Noise Figure	NF	1.1	1.3	1.5	dB
Active Input Third Order Intercept Point	IIP3	2.5	3.5	4.5	dBm
Active Input 1dB Compression Point	P _{1dB}	-6.0	-5	-4	dBm
Active Current @ 2.75 V	I _{CC}	2.3	2.8	3.8	mA
Bypass Gain	G	-4.2	-3.2	-2.2	dB
Bypass Noise Figure	NF	3.0	4.2	6	dB
Bypass Input Third Order Intercept Point	IIP3	22.5	24.5	25.5	dBm
Bypass Current		2	4	20	μ A

Table 4. Electrical Characteristics Measured in Frequency Specific Tuned Circuits (continued) $(V_{CC} = 2.75\text{ V}, T_A = 25^\circ\text{C}, R_{bias} = 2\text{ k}\Omega, \text{ unless otherwise noted.})$

Characteristic	Symbol	Minimum	Typical	Maximum	Unit
2140 MHz (R1 = 1.5 kΩ, R2 = 10 kΩ, C2 = 1 pF) (Refer to Figure 11)					
Frequency	f	—	2140	—	MHz
Active Gain	G	14.5	15.7	17.5	dB
Active Noise Figure	NF	1.1	1.3	1.8	dB
Active Input Third Order Intercept Point	IIP3	2	5	5.5	dBm
Active Input 1dB Compression Point	P _{1dB}	-5	-4	-3	dBm
Active Current @ 2.75 V	I _{CC}	3.4	4.45	5.5	mA
Bypass Gain	G	-5	-4	-3	dB
Bypass Noise Figure	NF	3.2	4.2	6	dB
Bypass Input Third Order Intercept Point	IIP3	18	20	21	dBm
Bypass Current		2	4	20	μ A
2140 MHz (R1 = 1.2 kΩ, R2 = 3.3 kΩ, R3 = 10 kΩ, C2 = 8 pF, C2 = 1 pF) (Refer to Figure 12)					
Frequency	f	—	2140	—	MHz
Active Gain	G	13.7	14.5	15.5	dB
Active Noise Figure	NF	1.3	1.49	1.65	dB
Active Input Third Order Intercept Point	IIP3	3.5	5.0	6.0	dBm
Active Input 1dB Compression Point	P _{1dB}	-8	-7	-6	dBm
Active Current @ 2.75 V	I _{CC}	3.9	4.45	5.5	mA
Bypass Gain	G	-4.9	-4.4	-3.9	dB
Bypass Noise Figure	NF	3	4.3	6	dB
Bypass Input Third Order Intercept Point	IIP3	18	20	21	dBm
Bypass Current		2	4	20	μ A
2400 MHz (Refer to Figure 13)					
Frequency	f	—	2400	—	MHz
Active Gain	G	13	14	16	dB
Active Noise Figure	NF	1.3	1.49	1.65	dB
Active Input Third Order Intercept Point	IIP3	3.0	4.0	5.0	dBm
Active Input 1dB Compression Point	P _{1dB}	-5.0	-3.8	-3	dBm
Active Current @ 2.75 V	I _{CC}	2.3	2.8	3.2	mA
Bypass Gain	G	-4.5	-3.6	-2.9	dB
Bypass Noise Figure	NF	3.2	4.2	6	dB
Bypass Input Third Order Intercept Point	IIP3	22	24	25	dBm
Bypass Current		2	4	20	μ A

Table 5. Truth Table

Pin Function	Pin Name	Enable		Disable	
		Low Gain	High Gain	Low Gain	High Gain
Circuit Bias VCC1	VCC1	1	1	1	1
Toggles Gain Mode (Active or Bypass)	GAIN	0	1	0	1
Toggles LNA On/Off	ENABLE	1	1	0	0
LNA Bias VCC3	LNA Out	1	1	1	1

NOTES: 1. Logic state "1" equals V_{CC} voltage. Logic state of "0" equals ground potential.
 2. VCC3 is inductively coupled to LNA OUT pin
 3. Minimum logic state "1" for enable and gain pins is 1.25 V.
 4. Minimum logic state "0" for enable and gain pins is 0.8 V.

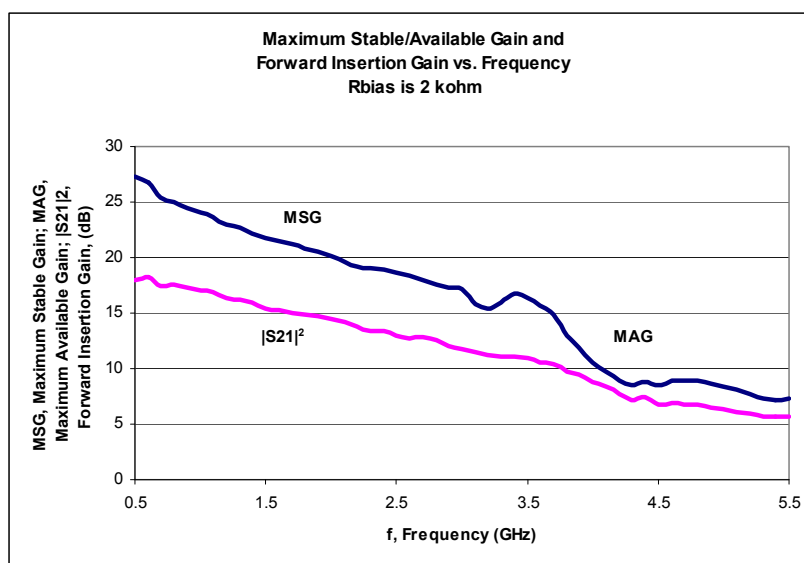

Figure 2. Maximum Stable/Available Gain and Forward Insertion Gain vs. Frequency (Rbias = 2 kΩ)

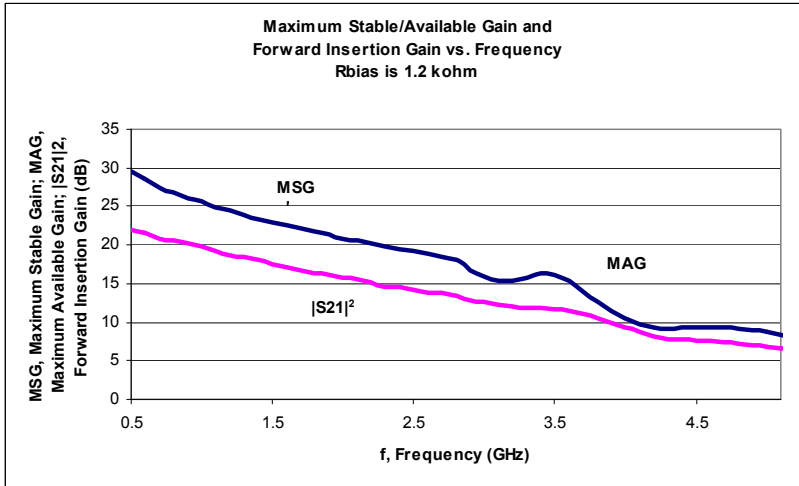

Figure 3. Maximum Stable/Available Gain and Forward Insertion Gain vs. Frequency (Rbias = 1.2 kΩ)

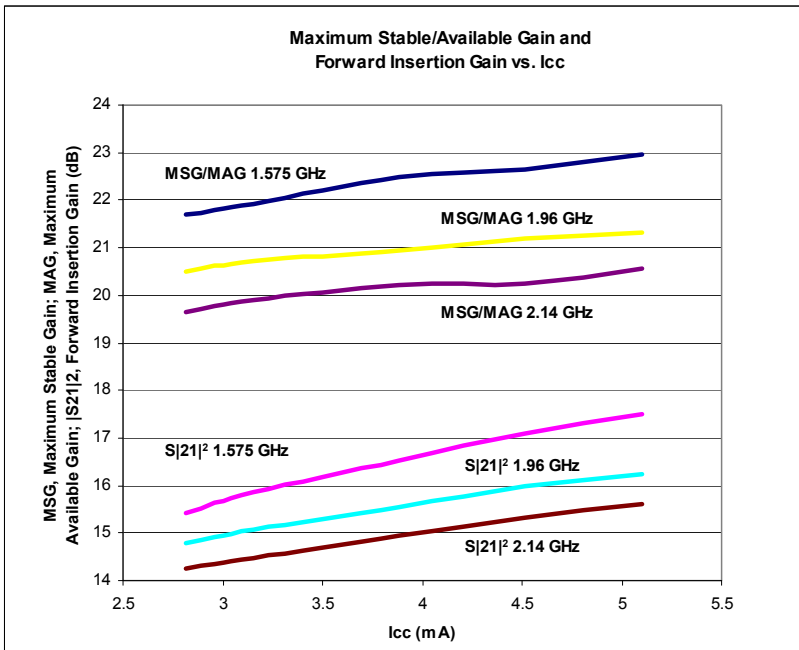

Figure 4. Maximum Stable/Available Gain and Forward Insertion Gain vs. Icc

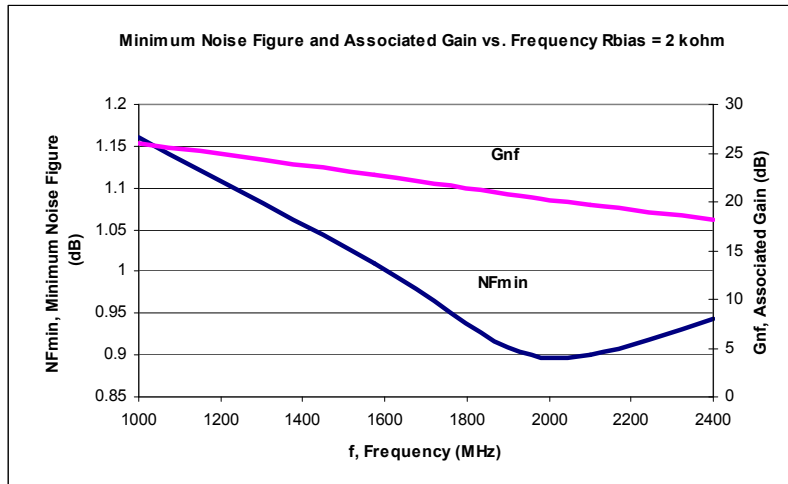

Figure 5. Minimum Noise Figure and Associated Gain vs. Frequency (Rbias = 2 kΩ)

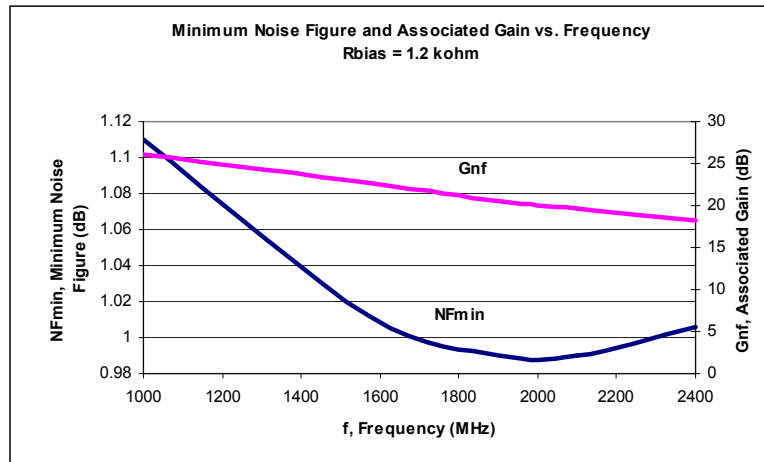

Figure 6. Minimum Noise Figure and Associated Gain vs. Frequency (Rbias = 1.2 kΩ)

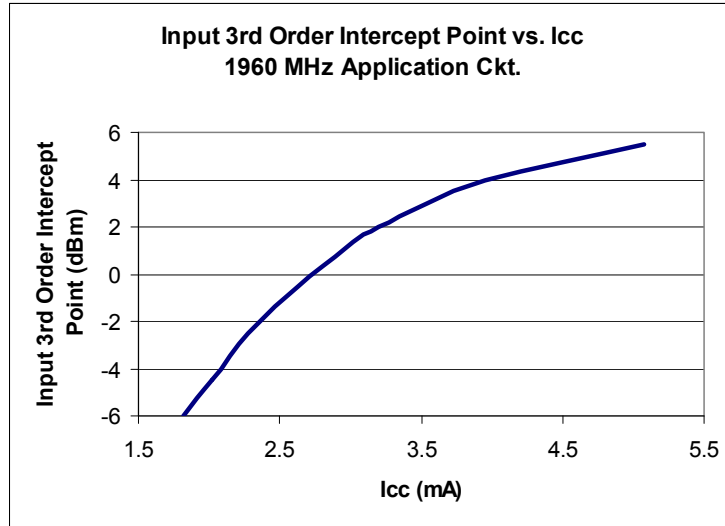

Figure 7. Input 3rd Order Intercept Point vs. I_{CC} for the 1960 MHz Application Circuit (R_{bias} varied from 1.2 kΩ to 3 kΩ)

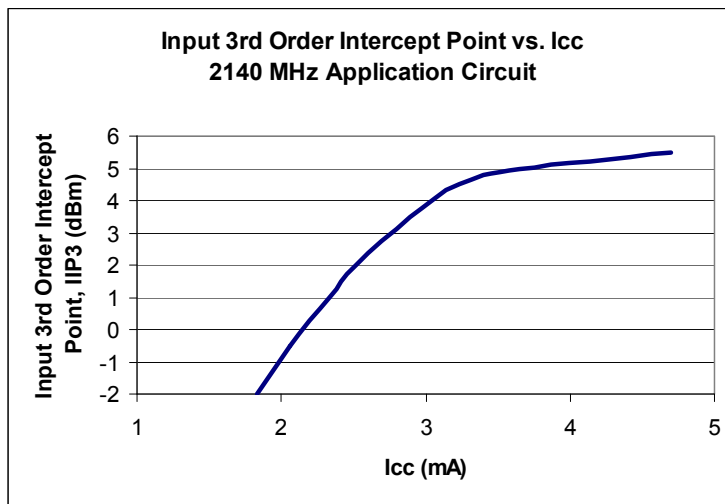

Figure 8. Input 3rd Order Intercept Point vs. I_{CC} for the 2140 MHz Application Circuit (R_{bias} varied from 1.2 kΩ to 3 kΩ)

3 Application Information

The MC13821 SiGe:C LNA is designed for applications in the 1000 MHz to 2.4 GHz range. It has three different modes: High Gain, Low Gain (Bypass) and Disabled. The IC is programmable through the Gain and Enable pins. The logic truth table is given in [Table 5](#).

In these application examples a balance is made between the competing RF performance characteristics of I_{CC}, NF, gain, IP3 and return losses with unconditional stability. Conjugate matching is not used for the input or output. Instead, matching which achieves a trade-off in RF performance qualities is utilized. For a particular application or spec requirement, the matching can be changed to achieve enhanced performance of one parameter at the expense of other parameters.

Application information for 1575, 1960, 2140 and 2400 MHz are shown. For each application, two current drain examples are provided. Typical RF performance is shown for two values of bias resistor R1: 1.2 k Ω and 2 k Ω , see [Table 6](#), [Table 7](#), [Table 8](#), and [Table 9](#). These two current drain states offer variation in intercept point, gain, and noise figure. For 1960 and 2140 MHz, additional application circuits are shown. These demonstrate specific performance characteristics and utilize varying input and output matches and different biasing resistors.

Measurements are made at a bias of $V_{CC} = 2.75$ V. Freq. spacing for IP3 measurements is 200 kHz. Non-linear measurements are made at $P_{in} = -30$ dB. The board loss corrections for these boards are: Input 0.16 dB, Output 0.2 dB. Gain and NF results incorporate these corrections in order to better reflect the actual performance of the device.

3.1 1575 MHz Application

This application circuit was designed to provide $NF < 1.2$ dB, S_{21} gain > 18 dB, OIP3 of 18 dBm with S_{11} better than -10 dB and S_{22} better than -10 dB at 1575 MHz with unconditional stability from 100 MHz to 10 GHz. Typical performance that can be expected from this circuit at 2.75 V V_{CC} is listed in [Table 6](#). The component values can be changed to enhance the performance of a particular parameter, but usually at the expense of another. Two variations of the circuit are realized for different requirements for IP3 and I_{CC} . Values of external resistors R1 and R2 are varied to adjust I_{CC} and IP3.

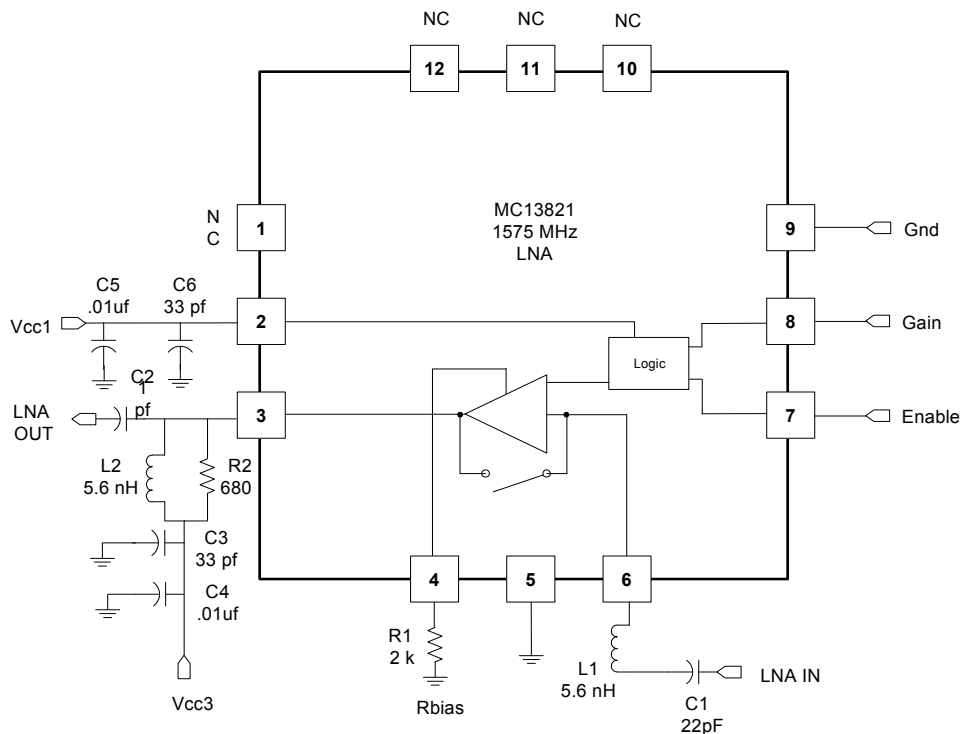

Figure 9. 1575 MHz LNA Application Schematic

Table 6. Typical 1575 MHz LNA Demo Board Performance
 (Resistor values of R1 and R2 are changed for different I_{CC} and IP3 requirements.)

Characteristic	Symbol	Minimum	Typical	Maximum	Unit
R1 = 1.2 kΩ, R2 = 620 Ω					
Frequency	f	—	1575.42	—	MHz
Power Gain	G				dB
High Gain		17	18	19	
Bypass		-6	-4.7	-4	
Output Third Order Intercept Point	OIP3				dBm
High Gain		16	20	22	
Bypass		18	20.8	22.5	
Input Third Order Intercept Point	IIP3				dBm
High Gain		-1	2.0	3.0	
Bypass		24	25.5	26.5	
Out Ref P1dB	P _{1dBout}				dBm
High Gain		8	10	12	
Bypass		—	—	—	
In Ref P1dB	P _{1dBin}				dBm
High Gain		-9	-8.0	-7.0	
Bypass		—	—	—	
Noise Figure	NF				dB
High Gain		1.0	1.25	1.45	
Bypass		3.9	4.8	6	
Current Drain	I _{CC}				mA
High Gain		3.9	4.45	5.5	
Bypass		2.0	4.0	20	μ A
Rbias R1 Value		—	1.2	—	k Ω
Rstability R2 Value		—	620	—	Ω
Input Return Loss	S11				dB
High Gain		—	-15.5	-10	
Bypass		—	-8.1	-5	
Gain	S21				dB
High Gain		16	18.0	19	
Bypass		-6	-4.1	-3.1	
Reverse Isolation	S12				dB
High Gain		-22	-23.7	—	
Bypass		-3	-4.4	—	
Output Return Loss	S22				dB
High Gain		—	-13.9	-11	
Bypass		—	-6.8	-5	
R1 = 2.0 kΩ, R2 = 680 Ω					
Frequency	f	—	1575.42	—	MHz

Table 6. Typical 1575 MHz LNA Demo Board Performance (continued)(Resistor values of R1 and R2 are changed for different I_{CC} and IP3 requirements.)

Characteristic	Symbol	Minimum	Typical	Maximum	Unit
Power Gain High Gain Bypass	G	16 -6	17.7 -5.0	18.7 -4	dB
Output Third Order Intercept Point High Gain Bypass	OIP3	16 18	18.5 21.7	20.5 —	dBm
Input Third Order Intercept Point High Gain Bypass	IIP3	-1 24	0.5 26	1.5 27	dBm
Out Ref P1dB High Gain Bypass	P_{1dBout}	6 —	8 —	9.7 —	dBm
In Ref P1dB High Gain Bypass	P_{1dBin}	-11 —	-10 —	-9 —	dBm
Noise Figure High Gain Bypass	NF	1.0 3.9	1.25 4.8	1.45 6	dB
Current Drain High Gain Bypass	I_{CC}	2.3 2.0	2.8 4.0	3.3 20	mA μ A
Rbias R1 Value		—	2.0	—	k Ω
Rstability R2 Value		—	680	—	Ω
Input Return Loss High Gain Bypass	S11	— —	-13.5 -9.0	-10 -7	dB
Gain High Gain Bypass	S21	16 -6	17.7 -4.1	18.7 -3.1	dB
Reverse Isolation High Gain Bypass	S12	-22 -3	-22.9 -4.3	— —	dB
Output Return Loss High Gain Bypass	S22	— —	-10.8 -7.2	-9 -5	dB

3.2 1960 MHz Application

These application circuits are designed to demonstrate performance at 1960 MHz. By varying the value of resistor R1, the current draw and the IP3 performance of the device can be tailored for a particular application. Shown here are four variations of the circuit for different IP3 and I_{CC} requirements. The input and output matches are also changed on some circuits to demonstrate different NF and gain performance. Typical performance that can be expected from this circuit at 2.75 V V_{CC} is listed in Table 7. Two variations of the circuit utilize different matches. For all circuits the match consists of a highpass match on the output and a simple inductor-capacitor network on the LNA input.

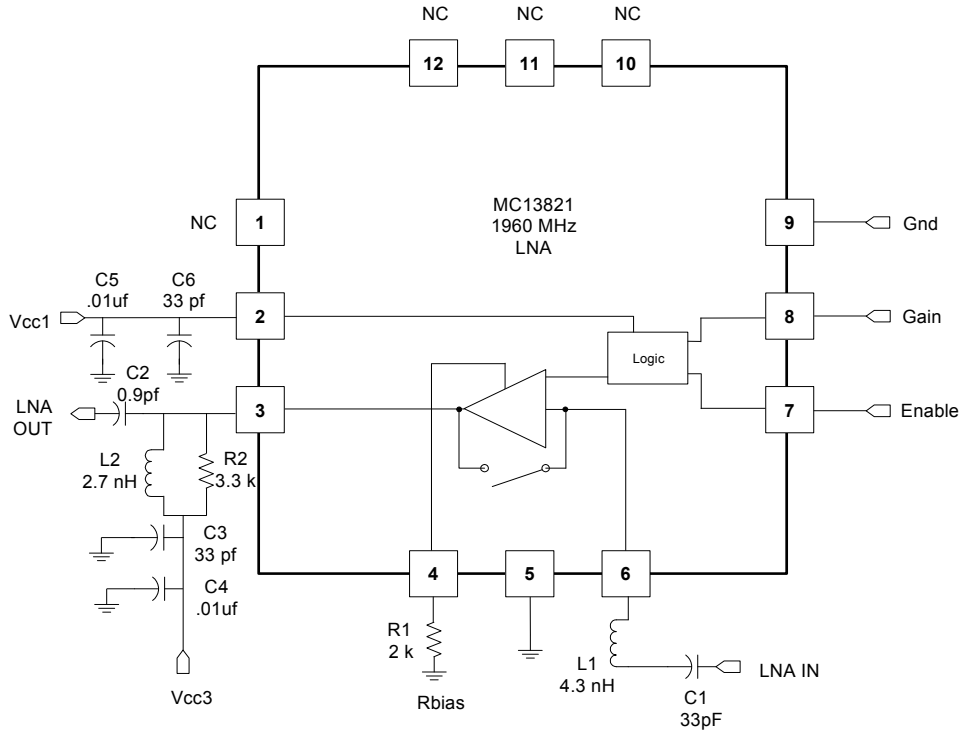

Figure 10. 1960 MHz LNA Application Schematic

Table 7. Typical 1960 MHz LNA Demo Board Performance
(Resistor values of R1 and R2 are changed for different I_{CC} and IP3 requirements.)

Characteristic	Symbol	Minimum	Typical	Maximum	Unit
R1 = 1.2 kΩ, R2 = 3.3 kΩ					
Frequency	f	—	1960	—	MHz
Power Gain	G				dB
High Gain		15	16	17	
Bypass		-6	-4.5	-3.5	
Output Third Order Intercept Point	OIP3				dBm
High Gain		19	22	23	
Bypass		18	20.5	21.5	

Table 7. Typical 1960 MHz LNA Demo Board Performance (continued)(Resistor values of R1 and R2 are changed for different I_{CC} and IP3 requirements.)

Characteristic	Symbol	Minimum	Typical	Maximum	Unit
Input Third Order Intercept Point High Gain Bypass	IIP3	4 24	5.5 25	6.0 26	dBm
Out Ref P1dB High Gain Bypass	P _{1dBout}	8 —	10.5 —	12.0 —	dBm
In Ref P1dB High Gain Bypass	P _{1dBin}	-7 —	-6.0 —	-5.0 —	dBm
Noise Figure High Gain Bypass	NF	1.0 3.9	1.26 4.5	1.45 6	dB
Current Drain High Gain Bypass	I _{CC}	3.9 2	4.45 4	5.5 20	mA μA
Rbias R1 Value		—	1.2	—	kΩ
Rstability R2 Value		—	3.3	—	kΩ
Input Return Loss High Gain Bypass	S11	— —	-9.7 -8.7	-7 -6	dB
Gain High Gain Bypass	S21	15 -6	16.4 -3.8	17.4 -3.0	dB
Reverse Isolation High Gain Bypass	S12	-20 -3	-21.7 -4.2	— —	dB
Output Return Loss High Gain Bypass	S22	— —	-14.6 -6.3	-10 -5	dB
R1 = 2.0 kΩ, R2 = 3.3 kΩ					
Frequency	f	—	1960	—	MHz
Power Gain High Gain Bypass	G	15 -5	16.4 -4.0	17.4 -3.0	dB
Output Third Order Intercept Point High Gain Bypass	OIP3	15.5 19	17.4 21	19.4 23	dBm
Input Third Order Intercept Point High Gain Bypass	IIP3	-0.5 23	1.0 25	2.0 26	dBm

Table 7. Typical 1960 MHz LNA Demo Board Performance (continued)(Resistor values of R1 and R2 are changed for different I_{CC} and IP3 requirements.)

Characteristic	Symbol	Minimum	Typical	Maximum	Unit
Out Ref P1dB High Gain Bypass	P _{1dBout}	8.5 —	10.4 —	12.4 —	dBm
In Ref P1dB High Gain Bypass	P _{1dBin}	-7 —	-6.0 —	-5 —	dBm
Noise Figure High Gain Bypass	NF	1.0 3.9	1.25 4.7	1.45 6	dB
Current Drain High Gain Bypass	I _{CC}	2.3 2	2.8 4.0	3.3 20	mA μA
Rbias R1 Value		—	2.0	—	kΩ
Rstability R2 Value		—	3.3	—	kΩ
Input Return Loss High Gain Bypass	S ₁₁	— —	-9.2 -9.8	-7 -7	dB
Gain High Gain Bypass	S ₂₁	15 -6	16.4 -3.9	17.4 -3.0	dB
Reverse Isolation High Gain Bypass	S ₁₂	-20 -3	-21.1 -4.0	— —	dB
Output Return Loss High Gain Bypass	S ₂₂	— —	-25 -7.8	-10 -6	dB
R1 = 1.3 kΩ, R2 = 68 Ω, C1 = 15 pF, C2 = 1.2 pF, L1 = 5.6 nH					
Frequency	f	—	1960	—	MHz
Power Gain High Gain Bypass	G	10.5 -6.5	11.5 -3.5	12.5 -3	dB
Output Third Order Intercept Point High Gain Bypass	OIP3	8.5 13.5	11.5 17.5	13.5 19	dBm
Input Third Order Intercept Point High Gain Bypass	IIP3	-2 20	0 21	1 22	dBm
Out Ref P1dB High Gain Bypass	P _{1dBout}	1 —	5.5 —	— —	dBm

Table 7. Typical 1960 MHz LNA Demo Board Performance (continued)(Resistor values of R1 and R2 are changed for different I_{CC} and IP3 requirements.)

Characteristic	Symbol	Minimum	Typical	Maximum	Unit
In Ref P1dB High Gain Bypass	P _{1dBIn}	-15 —	-10 —	—	dBm
Noise Figure High Gain Bypass	NF	1.0 3.8	1.3 4.7	1.9 6	dB
Current Drain High Gain Bypass	I _{CC}	3.6 2	4.5 4	5.5 20	mA μA
Rbias R1 Value			1.3		kΩ
Rstability R2 Value			68		Ω
Input Return Loss High Gain Bypass	S11	— —	-10 -10	-7 -7	dB
Gain High Gain Bypass	S21	10.5 -6.5	11.5 -3.5	13 -3	dB
Reverse Isolation High Gain Bypass	S12	-19 -4	-20 -7	— —	dB
Gain High Gain Bypass	S22	— —	-9.5 -7.6	-7 -6	dB
R1 = 1.8 kΩ, R2 = 330 Ω, C1 = 8 pF, C2 = 1.2 pF, L1 = 4.7 nH					
Frequency	f	—	1960	—	MHz
Power Gain High Gain Bypass	G	14 -6.5	15 -3.5	16 -3	dB
Output Third Order Intercept Point High Gain Bypass	OIP3	12 9.5	15 14.5	17 15.5	dBm
Input Third Order Intercept Point High Gain Bypass	IIP3	-2 16	0 18	1 18.5	dBm
Out Ref P1dB High Gain Bypass	P _{1dBOut}	1 —	10 —	12 —	dBm
In Ref P1dB High Gain Bypass	P _{1dBIn}	-10 —	-5 —	-4 —	dBm

Table 7. Typical 1960 MHz LNA Demo Board Performance (continued)
 (Resistor values of R1 and R2 are changed for different I_{CC} and IP3 requirements.)

Characteristic	Symbol	Minimum	Typical	Maximum	Unit
Noise Figure High Gain Bypass	NF	1.1 3.8	1.3 4.7	1.9 6	dB
Current Drain High Gain Bypass	I_{CC}	2.3 2	2.8 4	5.5 20	mA μ A
Rbias R1 Value		—	1.8	—	k Ω
Rstability R2 Value		—	330	—	Ω
Input Return Loss High Gain Bypass	S11	— —	-9.2 -9.8	-7 -7	dB
Gain High Gain Bypass	S21	13.8 —	14.8 -3.9	16 —	dB
Reverse Isolation High Gain Bypass	S12	-19 -3	-21 -4	— —	dB
Gain High Gain Bypass	S22	— —	-17 -7.8	-12 -6	dB
Single Tone IIP3 ($F_{in} = 653.3$ MHz, $F_{out} = 1960$ MHz)	IIP3	-13	-9	-8	dBm
Single Tone IIP2 ($F_{in} = 980$ MHz, $F_{out} = 1960$ MHz)	IIP2	-11	-6	-5	dBm
Two Tone IIP2 ($F_1 = 1880$ MHz, $F_2 = 3840$ MHz, $F_{out} = 1960$ MHz)	IIP2	1	7	7.5	dBm
Two Tone IIP3 ($F_1 = 1880$ MHz, $F_2 = 5720$ MHz, $F_{out} = 1960$ MHz)	IIP3	-1.5	3.5	4.0	dBm

3.3 2140 MHz Application

These application circuits demonstrate performance at 2140 MHz. Resistor values for R1 and R2 are varied to adjust I_{CC} , which also adjusts IP3 performance. Matching component values can be changed to enhance a particular parameter, but usually at the expense of another. Typical performance that can be expected from this circuit at 2.75 V V_{CC} is listed in Table 8. Three variations of the circuit are realized for different requirements for IP3 and I_{CC} . The same matching networks are used on the 2140 MHz circuit as on the 1960 MHz application circuit, with a highpass match on the output and a simple inductor-capacitor network on the LNA input.

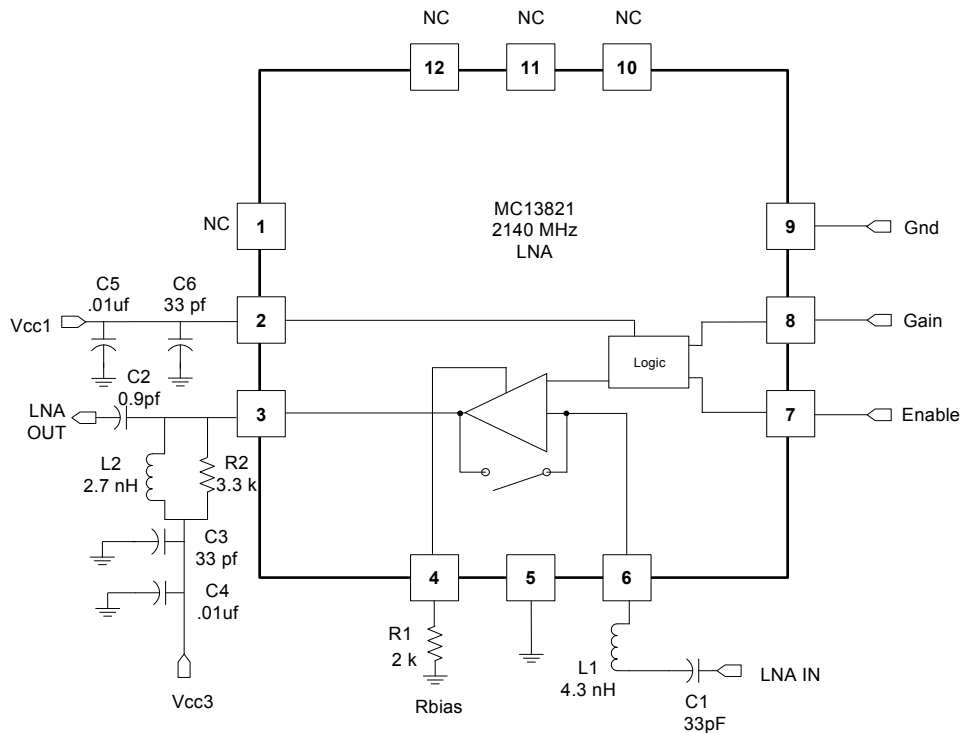

Figure 11. 2140 MHz LNA Application Schematic

Table 8. Typical 2140 MHz LNA Demo Board Performance

(Resistor values of R1 and R2 are changed for different I_{CC} and IP3 requirements.)

Characteristic	Symbol	Min	Typ	Max	Unit
R1 = 1.2 kΩ, R2 = 3.3 kΩ					
Frequency	f	—	2140	—	MHz
Power Gain	G				dB
High Gain		14.7	15.7	16.7	
Bypass		-4.4	-3.4	-2.5	
Output Third Order Intercept Point	OIP3				dBm
High Gain		18.2	20.7	22.7	
Bypass		13	16.4	18.5	

Table 8. Typical 2140 MHz LNA Demo Board Performance (continued)(Resistor values of R1 and R2 are changed for different I_{CC} and IP3 requirements.)

Characteristic	Symbol	Min	Typ	Max	Unit
Input Third Order Intercept Point High Gain Bypass	IIP3	3.5 18	5.0 20	6.0 21	dBm
Out Ref P1dB High Gain Bypass	P _{1dBout}	8.7 —	10.7 —	12.7 —	dBm
In Ref P1dB High Gain Bypass	P _{1dBin}	-6 —	-5.0 —	-4 —	dBm
Noise Figure High Gain Bypass	NF	1.3 3	1.49 3.4	1.65 6	dB
Current Drain High Gain Bypass	I _{CC}	3.9 2	4.45 4	5.5 20	mA μA
Rbias R1 Value		—	1.2	—	kΩ
Rstability R2 Value		—	3.3	—	kΩ
Input Return Loss High Gain Bypass	S11	— —	-8.5 -8.9	-7 -7	dB
Gain High Gain Bypass	S21	14.7 -6	15.8 -4.1	16.7 -3	dB
Reverse Isolation High Gain Bypass	S12	-20 -3.5	-22.2 -4.5	— —	dB
Output Return Loss High Gain Bypass	S22	— —	-12.5 -6.1	-10 -5	dB
R1 = 1.2 kΩ, R2 = 3.3 kΩ, R2 = 10 Ω, C1 = 8pF, C2 = 1 pF					
Frequency	f	—	2140	—	MHz
Power Gain High Gain Bypass	G	13.7 -4.9	14.5 -4.4	15.5 -3.9	dB
Output Third Order Intercept Point High Gain Bypass	OIP3	17.2 15.1	19.5 17.6	21.5 20.1	dBm
Input Third Order Intercept Point High Gain Bypass	IIP3	3.5 20	5.0 22	6.0 24	dBm

Table 8. Typical 2140 MHz LNA Demo Board Performance (continued)(Resistor values of R1 and R2 are changed for different I_{CC} and IP3 requirements.)

Characteristic	Symbol	Min	Typ	Max	Unit
Out Ref P1dB High Gain Bypass	P _{1dBout}	5.7 —	7.5 —	9.5 —	dBm
In Ref P1dB High Gain Bypass	P _{1dBin}	-8 —	-7 —	-6 —	dBm
Noise Figure High Gain Bypass	NF	1.3 3	1.49 4.3	1.65 6	dB
Current Drain High Gain Bypass	I _{CC}	3.9 2	4.45 4	5.5 20	mA μA
Rbias R1 Value		—	1.2	—	kΩ
Rstability R2 Value		—	3.3	—	kΩ
Rstability R2 Value		—	10	—	Ω
Input Return Loss High Gain Bypass	S11	— —	-11 -12	-10 -10	dB
Gain High Gain Bypass	S21	13.7 -4.9	14.5 -4.4	15.5 -3.9	dB
Reverse Isolation High Gain Bypass	S12	-20 -3.5	-22 -4.4	— —	dB
Output Return Loss High Gain Bypass	S22	— —	-14 -14	-10 -10	dB
R1 = 2.0 kΩ, R2 = 3.3 kΩ					
Frequency	f	—	2140	—	MHz
Power Gain High Gain Bypass	G	14.7 -4.2	15.7 -3.2	17.5 -2.2	dB
Output Third Order Intercept Point High Gain Bypass	OIP3	17.8 18.3	19.2 21.3	21 23.3	dBm
Input Third Order Intercept Point High Gain Bypass	IIP3	2.5 22.5	3.5 24.5	4.5 25.5	dBm
Out Ref P1dB High Gain Bypass	P _{1dBout}	8.7 —	10.7 —	12.5 —	dBm

Table 8. Typical 2140 MHz LNA Demo Board Performance (continued)(Resistor values of R1 and R2 are changed for different I_{CC} and IP3 requirements.)

Characteristic	Symbol	Min	Typ	Max	Unit
In Ref P1dB High Gain Bypass	P _{1dBIn}	-6 —	-5.0 —	-4 —	dBm
Noise Figure High Gain Bypass	NF	1.1 3.2	1.3 4.2	1.5 6	dB
Current Drain High Gain Bypass	I _{CC}	2.3 2	2.8 4	3.8 20	mA μA
Rbias R1 Value		—	2.0	—	kΩ
Rstability R2 Value		—	3.3	—	kΩ
Input Return Loss High Gain Bypass	S11	— —	-13.7 -17.1	-10 -10	dB
Gain High Gain Bypass	S21	14.7 -4	15.7 -3.0	17.5 —	dB
Reverse Isolation High Gain Bypass	S12	-19 -2.5	-20.9 -3.3	— —	dB
Output Return Loss High Gain Bypass	S22	— —	-12.1 -14.6	-10 -10	dB
R1 = 1.5 kΩ, R2 = 10 kΩ, C2 = 1 pF					
Frequency	f		2140		MHz
Power Gain High Gain Bypass	G	14.5 -5	15.7 -4	17.5 -3	dB
Output Third Order Intercept Point High Gain Bypass	OIP3	16.5 13	20.7 16	23 18	dBm
Input Third Order Intercept Point High Gain Bypass	IIP3	2 18	5 20	5.5 21	dBm
Out Ref P1dB High Gain Bypass	P _{1dBOut}	9.5 —	12 —	14.5 —	dBm
In Ref P1dB High Gain Bypass	P _{1dBIn}	-5 —	-4 —	-3 —	dBm

Table 8. Typical 2140 MHz LNA Demo Board Performance (continued)(Resistor values of R1 and R2 are changed for different I_{CC} and IP3 requirements.)

Characteristic	Symbol	Min	Typ	Max	Unit
Noise Figure High Gain Bypass	NF	1.1 4	1.3 5	1.8 6	dB
Current Drain High Gain Bypass	I_{CC}	3.4 2	4.45 4	5.5 20	mA μ A
Rbias R1 Value		—	1.5	—	k Ω
Rstability R2 Value		—	10	—	k Ω
Input Return Loss High Gain Bypass	S11	— —	-8.5 -8.9	-7 -7	dB
Gain High Gain Bypass	S21	14.5 -5	15.7 -4	17.5 —	dB
Gain High Gain Bypass	S12	-19 -3	-20 -4	— —	dB
Gain High Gain Bypass	S22	-10.5 -8	-12.5 -6.1	— —	dB
Single Tone IIP3 ($F_{in} = 713.3$ MHz, $F_{out} = 2140$ MHz)	IIP3	-14	-9.5	—	dBm
Single Tone IIP2 ($F_{in} = 1070$ MHz, $F_{out} = 2140$ MHz)	IIP2	-10.5	-5.5	—	dBm
Two Tone IIP2 ($F_1 = 1950$ MHz, $F_2 = 4090$ MHz, $F_{out} = 2140$ MHz)	IIP2	-4.5	1.5	—	dBm
Two Tone IIP3 ($F_1 = 1950$ MHz, $F_2 = 6040$ MHz, $F_{out} = 2140$ MHz)	IIP3	-2	5	—	dBm

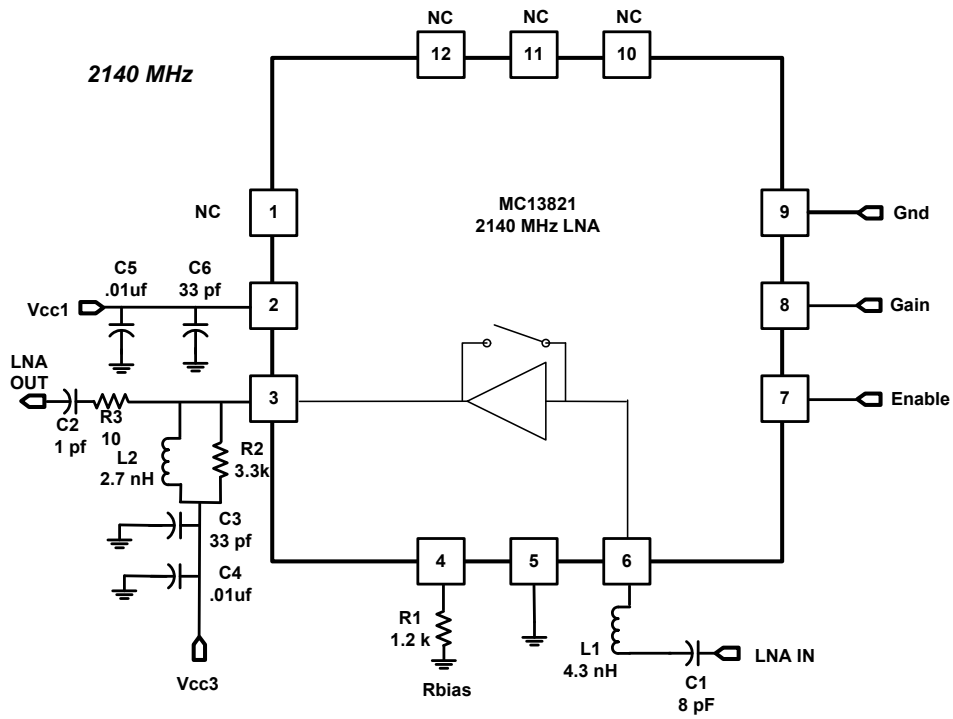

Figure 12. 2140 MHz LNA Application Schematic with R3 Output Resistor Added

3.4 2400 MHz Application

This application circuit was designed to provide $NF < 1.3$ dB, S_{21} gain > 16 dB, $OIP3$ of 18 dBm with S_{11} better than -10 dB and S_{22} better than -10 dB at 2140 MHz with unconditional stability from 100 MHz to 10 GHz. Typical performance that can be expected from this circuit at 2.75 V V_{CC} is listed in Table 9. The component values can be changed to enhance the performance of a particular parameter, but usually at the expense of another. Two variations of the circuit are realized for different requirements for $IP3$ and I_{CC} . Values of external resistors $R1$ and $R2$ are varied to adjust I_{CC} and $IP3$.

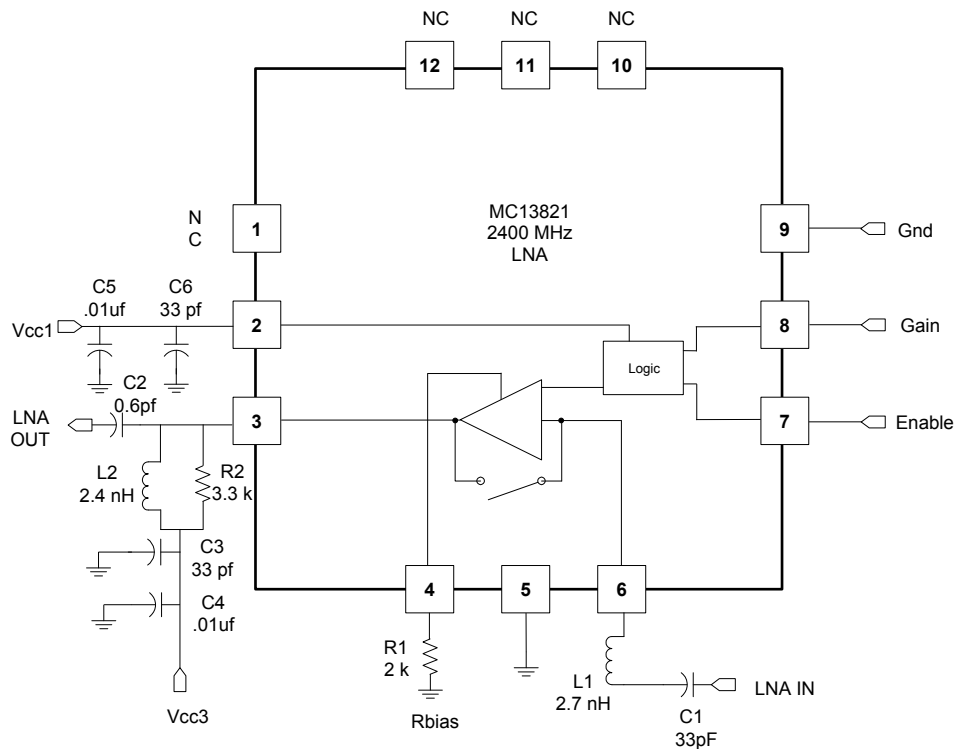

Figure 13. 2400 MHz LNA Application Schematic

Table 9. Typical 2400 MHz LNA Demo Board Performance

(Resistor values of $R1$ and $R2$ are changed for different I_{CC} and $IP3$ requirements.)

Characteristic	Symbol	Minimum	Typical	Maximum	Unit
$R1 = 1.2$ kΩ, $R2 = 3.3$ kΩ					
Frequency	f	—	2400	—	MHz
Power Gain	G				dB
High Gain		13	14	15	
Bypass		-5	-3.8	-3	
Output Third Order Intercept Point	OIP3				dBm
High Gain		18.5	21	22.5	
Bypass		15	19	20	
Input Third Order Intercept Point	IIP3				dBm
High Gain		5.5	7.0	7.5	
Bypass		20	22	23	

Table 9. Typical 2400 MHz LNA Demo Board Performance (continued)(Resistor values of R1 and R2 are changed for different I_{CC} and IP3 requirements.)

Characteristic	Symbol	Minimum	Typical	Maximum	Unit
Out Ref P1dB High Gain Bypass	P _{1dBout}	8 —	10.7 —	12 —	dBm
In Ref P1dB High Gain Bypass	P _{1dBin}	-5 —	-4 —	-3 —	dBm
Noise Figure High Gain Bypass	NF	1.35 —	1.55 3.8	1.7 6	dB
Current Drain High Gain Bypass	I _{CC}	3.4 2	4.45 4	5.5 20	mA μA
Rbias R1 Value		—	1.2	—	kΩ
Rstability R2 Value		—	3.3	—	kΩ
Input Return Loss High Gain Bypass	S11	— —	-8.5 -8.9	-7 -7	dB
Gain High Gain Bypass	S21	13 -5	14 -4.1	15 -3	dB
Reverse Isolation High Gain Bypass	S12	-19 -3	-20.2 -4.0	— —	dB
Output Return Loss High Gain Bypass	S22	— —	-11 -7.0	-9 -6	dB
R1 = 2.0 kΩ, R2 = 3.3 kΩ					
Frequency	f	—	2400	—	MHz
Power Gain High Gain Bypass	G	13 -5	14 -4	15 -3	dB
Output Third Order Intercept Point High Gain Bypass	OIP3	17 17	18.5 20	20 22	dBm
Input Third Order Intercept Point High Gain Bypass	IIP3	3.0 22	4.0 24	5.0 25	dBm
Out Ref P1dB High Gain Bypass	P _{1dBout}	8.5 —	10 —	12 —	dBm

Table 9. Typical 2400 MHz LNA Demo Board Performance (continued)(Resistor values of R1 and R2 are changed for different I_{CC} and IP3 requirements.)

Characteristic	Symbol	Minimum	Typical	Maximum	Unit
In Ref P1dB High Gain Bypass	P_{1dBin}	-5 —	-4.0 —	-3 —	dBm
Noise Figure High Gain Bypass	NF	1.3 3.2	1.49 4.2	1.65 6	dB
Current Drain High Gain Bypass	I_{CC}	2.3 2	2.8 4	4.5 20	mA μ A
Rbias R1 Value		—	2.0	—	k Ω
Rstability R2 Value		—	3.3	—	k Ω
Input Return Loss High Gain Bypass	S11	— —	-10 -9.7	-8 -8	dB
Gain High Gain Bypass	S21	13 -4.5	14 -3.6	15 -2.9	dB
Reverse Isolation High Gain Bypass	S12	-19 -3	-20 -3.8	— —	dB
Output Return Loss High Gain Bypass	S22	— —	-10 -9.1	-9 -8	dB

4 Printed Circuit Board

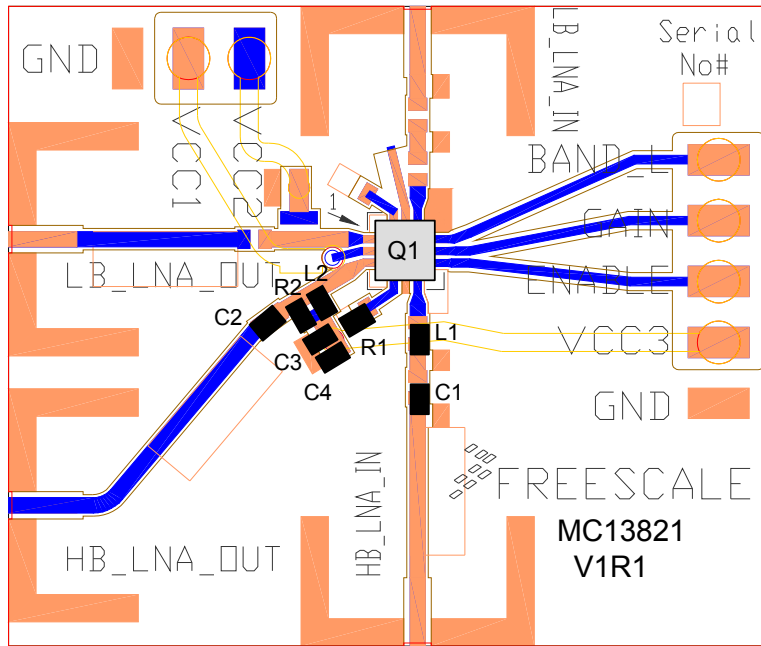

Note: Components C5 and C6 are located on the back of the board

Figure 14. Front Side

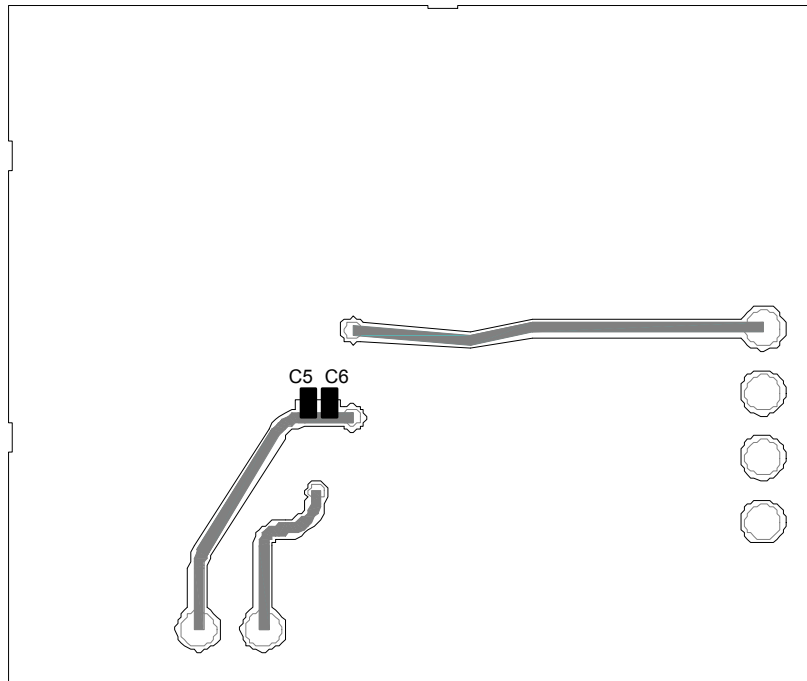

Figure 15. Back Side

Table 10. Bill of Materials

Component	Value	Case	Manufacturer	Comments
1575 MHz				
C1	22 pF	402	Murata	Input match
C2	1.0 pF	402	Taiyo Yuden	Output match
C3	33 pF	402	Murata	RF bypass
C4	.01 μ F	402	Murata	Low freq bypass
C5	.01 μ F	402	Murata	Low freq bypass
C6	33 pF	402	Murata	RF bypass
L2	5.6 nH	1005	CoilCraft	Output match
L1	5.6 nH	1005	CoilCraft	Input match
R1	1.2 or 2 k Ω	402	KOA	Bias for 4.45 or 2.8 mA
R2	620 or 680 Ω	402	KOA	Stability
Q1	MC13821	QFN-12	Freescale	
1960 MHz (16 dB Gain)				
C1	33 pF	402	Murata	Input match
C2	0.9 pF	402	Taiyo Yuden	Output match
C3	33 pF	402	Murata	RF bypass
C4	.01 μ F	402	Murata	Low freq bypass
C5	.01 μ F	402	Murata	Low freq bypass
C6	33 pF	402	Murata	RF bypass
L1	4.3 nH	1005	CoilCraft	Input match
L2	2.7 nH	1005	Coilcraft	Output match
R1	1.2 or 2 k Ω	402	KOA	Bias for 4.45 or 2.8 mA
R2	3.3 k Ω	402	KOA	Stability
Q1	MC13821	QFN-12	Freescale	
1960 MHz (11.5 dB Gain)				
C1	15 pF	402	Murata	Input match
C2	1.2 pF	402	Taiyo Yuden	Output match
C3	33 pF	402	Murata	RF bypass
C4	.01 μ F	402	Murata	Low freq bypass
C5	.01 μ F	402	Murata	Low freq bypass
C6	33 pF	402	Murata	RF bypass
L1	4.3 nH	1005	CoilCraft	Input match
L2	2.7 nH	1005	CoilCraft	Output match

Table 10. Bill of Materials (continued)

Component	Value	Case	Manufacturer	Comments
R2	68 Ω	402	KOA	Stability
R1	1.3 k Ω	402	KOA	Bias for 5.5 mA max.
Q1	MC13821	QFN-12	Freescale	
1960 MHz (15 dB Gain)				
C1	8 pF	402	Murata	Input match
C2	1.2 pF	402	Taiyo Yuden	Output match
C3	33 pF	402	Murata	RF bypass
C4	.01 μ F	402	Murata	Low freq bypass
C5	.01 μ F	402	Murata	Low freq bypass
C6	33 pF	402	Murata	RF bypass
L1	4.7 nH	1005	CoilCraft	Input match
L2	2.4 nH	1005	CoilCraft	Output match
R1	1.8 k Ω	402	KOA	Bias for 5.5 mA max.
R2	330 Ω	402	KOA	Stability
Q1	MC13821	QFN-12	Freescale	
2140 MHz				
C1	33 pF	402	Murata	Input match
C2	0.9 pF	402	Taiyo Yuden	Output match
C3	33 pF	402	Murata	RF bypass
C4	.01 μ F	402	Murata	Low freq bypass
C5	.01 μ F	402	Murata	Low freq bypass
C6	33 pF	402	Murata	RF bypass
L2	2.7 nH	1005	CoilCraft	Output match
L1	4.3 nH	1005	CoilCraft	Input match
R1	1.2 or 2 k Ω	402	KOA	Bias for 4.45 or 2.8 mA
R2	3.3 k Ω	402	KOA	Stability
Q1	MC13821	QFN-12	Freescale	
2140 MHz				
C1	8 pF	402	Murata	Input match
C2	1 pF	402	Murata	Output match
C3	33 pF	402	Murata	RF bypass
C4	.01 μ F	402	Murata	Low freq bypass
C5	.01 μ F	402	Murata	Low freq bypass

Table 10. Bill of Materials (continued)

Component	Value	Case	Manufacturer	Comments
C6	33 pF	402	Murata	RF bypass
L1	4.3 nH	1005	CoilCraft	Input match
L2	2.7 nH	1005	CoilCraft	Output match
R1	1.2 k Ω	402	KOA	Bias for 5.5 mA
R2	3.3 k Ω	402	KOA	Stability
R3	10 Ω	402	KOA	Stability
Q1	MC13821	QFN-12	Freescale	
2140 MHz				
C1	33 pF	402	Murata	Input match
C2	1.0 pF	402	Taiyo Yuden	Output match
C3	33 pF	402	Murata	RF bypass
C4	.01 μ F	402	Murata	Low freq bypass
C5	.01 μ F	402	Murata	Low freq bypass
C6	33 pF	402	Murata	RF bypass
L1	4.3 nH	1005	CoilCraft	Input match
L2	2.7 nH	1005	Coilcraft	Output match
R1	1.5 k Ω	402	KOA	Bias for 4.45 mA
R2	10 k Ω	402	KOA	Stability
Q1	MC13821	QFN-12	Freescale	
2400 MHz				
C1	33 pF	402	Murata	Input match
C2	0.6 pF	402	Taiyo Yuden	Output match
C3	33 pF	402	Murata	RF bypass
C4	.01 μ F	402	Murata	Low freq bypass
C5	.01 μ F	402	Murata	Low freq bypass
C6	33 pF	402	Murata	RF bypass
L1	2.7 nH	1005	CoilCraft	Input match
L2	2.4 nH	1005	CoilCraft	Output match
R2	3.3 k Ω	402	KOA	Stability
R1	1.2 or 2 k Ω	402	KOA	Bias for 4.5 or 2.8 mA
Q1	MC13821	QFN-12	Freescale	

5 Scattering Parameters

Table 11. Active Mode Scattering Parameters

 (V_{CC1} and $V_{CC3} = 2.75$ V, Band grounded, Gain = 2.75 V, Enable = 2.75 V, Rbias resistor R1 = 2 k Ω), $I_{CC} = 2.6$ mA

f GHz)	S ₁₁		S ₂₁		S ₁₂		S ₂₂	
	S ₁₁	$\angle \phi$	S ₁₁	$\angle \phi$	S ₁₁	$\angle \phi$	S ₁₁	$\angle \phi$
0.7	0.852	-29.22	7.029	142.03	0.021	75.16	0.956	-14.42
0.8	0.836	-32.9	7.279	137.43	0.024	73.13	0.946	-15.76
0.9	0.803	-36.02	7.034	133.48	0.027	70.95	0.966	-19.49
1	0.814	-42.84	6.856	127	0.029	66.71	0.887	-17.77
1.1	0.782	-42.6	6.687	125.21	0.031	68.53	0.924	-22.03
1.2	0.772	-45.55	6.29	122.03	0.034	65.83	0.898	-23.58
1.3	0.752	-47.28	6.242	116.95	0.036	65.66	0.897	-25.56
1.4	0.718	-50.24	6.082	114.12	0.039	64.76	0.912	-26.44
1.5	0.672	-52.29	5.696	112.14	0.04	61.29	0.943	-30.51
1.6	0.688	-49.98	5.662	107.49	0.043	61.9	0.882	-35.18
1.7	0.695	-53.95	5.499	104.8	0.044	60.95	0.865	-35.67
1.8	0.686	-54.86	5.348	101.62	0.047	60.42	0.866	-36.55
1.9	0.653	-57.19	5.334	97.81	0.05	59.47	0.892	-41.25
2	0.661	-57.81	5.098	95.37	0.052	60.14	0.863	-42.78
2.1	0.646	-60.4	5.035	90.65	0.058	56	0.844	-46.94
2.2	0.639	-62.48	4.766	86.29	0.058	52.65	0.818	-49.01
2.3	0.628	-61.9	4.575	86.75	0.059	51.95	0.8	-50.61
2.4	0.608	-63.13	4.529	82.12	0.06	52.38	0.78	-51.67
2.5	0.61	-63.96	4.366	79.31	0.063	53.62	0.779	-52.93
2.6	0.609	-65.96	4.251	77.33	0.067	51.2	0.777	-54.38
2.7	0.637	-69.48	4.307	75.4	0.072	50.86	0.811	-57.38
2.8	0.57	-74.63	4.168	68.94	0.073	46.36	0.756	-63.02
2.9	0.536	-75.03	3.933	65.73	0.075	42.72	0.716	-62.94
3	0.515	-75.6	3.819	62.83	0.074	42.14	0.697	-64.16
3.1	0.506	-75.28	3.665	61.56	0.074	39.24	0.683	-63.26
3.2	0.489	-73.7	3.572	60.5	0.07	39.17	0.702	-63.69
3.3	0.483	-74.54	3.523	58.09	0.07	43.49	0.716	-66.71
3.4	0.487	-76.91	3.495	55.25	0.075	46.63	0.714	-70.44
3.5	0.488	-78.25	3.484	51.93	0.082	45.9	0.699	-74.6

Table 12. Bypass Mode Scattering Parameters

((V_{CC1} and $V_{CC3} = 2.75V$, Band and Gain grounded, Enable = 2.75 V, Rbias resistor R1= 2 k Ω), $I_{CC} = 3.0 \mu A$)

f (GHz)	S ₁₁		S ₂₁		S ₁₂		S ₂₂	
	S ₁₁	$\angle \phi$	S ₁₁	$\angle \phi$	S ₁₁	$\angle \phi$	S ₁₁	$\angle \phi$
0.7	0.549	-51.13	0.578	17.83	0.583	18.83	0.578	-41.21
0.8	0.511	-53.94	0.596	13.17	0.6	14.15	0.542	-42.25
0.9	0.47	-55.73	0.608	8.45	0.614	10.08	0.524	-45.13
1	0.458	-59.65	0.615	3.3	0.617	5.12	0.455	-43.82
1.1	0.434	-58.46	0.624	1.11	0.628	2.52	0.453	-46.74
1.2	0.421	-59.33	0.629	-2.37	0.635	-0.96	0.42	-48.02
1.3	0.404	-59.6	0.634	-5.19	0.639	-3.8	0.407	-48.56
1.4	0.384	-61.06	0.633	-8.02	0.639	-6.66	0.394	-47.62
1.5	0.36	-62.48	0.638	-10.97	0.641	-9.5	0.388	-49.7
1.6	0.362	-59.49	0.638	-13.09	0.643	-11.89	0.374	-53.61
1.7	0.367	-60.21	0.639	-15.43	0.643	-14.26	0.353	-53.66
1.8	0.363	-60.18	0.64	-17.77	0.645	-16.58	0.335	-53.3
1.9	0.35	-63.26	0.645	-20.27	0.649	-19.08	0.348	-53.86
2	0.355	-63.18	0.639	-22.63	0.643	-21.39	0.327	-54.83
2.1	0.335	-66.36	0.64	-24.42	0.643	-23.2	0.342	-57.82
2.2	0.332	-65.87	0.64	-26.93	0.645	-25.56	0.324	-60.95
2.3	0.322	-63.97	0.64	-28.95	0.644	-27.79	0.309	-63.15
2.4	0.32	-63.46	0.639	-31.11	0.642	-30.01	0.294	-64.43
2.5	0.319	-63.28	0.632	-33.88	0.638	-32.07	0.279	-64.25
2.6	0.323	-63.96	0.627	-35.14	0.633	-33.64	0.274	-62.49
2.7	0.354	-65.66	0.64	-36.78	0.645	-35.11	0.297	-62.47
2.8	0.317	-73.59	0.637	-40.56	0.643	-38.92	0.282	-72.82
2.9	0.296	-74.61	0.622	-42.77	0.629	-41.1	0.245	-73.08
3	0.284	-74.6	0.616	-44.14	0.621	-42.65	0.23	-70.36
3.1	0.283	-72.89	0.616	-45.7	0.619	-43.94	0.236	-67.03
3.2	0.274	-72.04	0.618	-47.38	0.622	-45.84	0.245	-68.8
3.3	0.269	-74.74	0.618	-50.21	0.623	-48.62	0.238	-75.51
3.4	0.265	-77.34	0.609	-52.62	0.615	-51.03	0.212	-77.5
3.5	0.261	-76.71	0.603	-54.36	0.607	-52.96	0.194	-77.94

Table 13. Active Mode Scattering Parameters(V_{CC1} and V_{CC3} = 2.75 V, Band grounded, Gain and Enable = 2.75 V, R_{bias} resistor R1 = 1.2 k Ω , I_{CC} = 4.8 mA)

f (GHz)	S ₁₁		S ₂₁		S ₁₂		S ₂₂	
	S ₁₁	$\angle \phi$	S ₁₁	$\angle \phi$	S ₁₁	$\angle \phi$	S ₁₁	$\angle \phi$
0.7	0.784	-32.04	10.275	132.74	0.021	72.91	0.92	-15.77
0.8	0.765	-35.9	10.162	127.59	0.022	71.83	0.907	-16.82
0.9	0.721	-39	9.646	122.89	0.025	68.97	0.923	-20.31
1	0.724	-45.16	9.184	116.28	0.027	67.34	0.842	-18.21
1.1	0.692	-44.87	8.773	114.36	0.029	67.52	0.877	-22.39
1.2	0.678	-47.17	8.23	110.64	0.033	67.56	0.846	-23.69
1.3	0.662	-48.64	7.98	106.21	0.034	66.62	0.845	-25.47
1.4	0.626	-51.75	7.638	103.36	0.037	64.27	0.858	-25.98
1.5	0.576	-53.11	7.185	100.91	0.039	63.47	0.893	-29.67
1.6	0.594	-49.59	6.972	96.71	0.041	62.78	0.835	-34.46
1.7	0.599	-52.85	6.691	93.81	0.042	62.14	0.816	-34.49
1.8	0.594	-54.14	6.444	90.92	0.044	62.34	0.817	-35.3
1.9	0.56	-56.18	6.34	87.3	0.049	60.88	0.843	-39.86
2	0.568	-57.13	6.029	85.12	0.05	60.42	0.817	-41.18
2.1	0.548	-58.62	5.885	80.96	0.054	57.9	0.798	-45.47
2.2	0.546	-59.79	5.568	76.96	0.056	56.61	0.774	-46.98
2.3	0.543	-59.25	5.318	76.8	0.057	54.83	0.761	-48.63
2.4	0.532	-59.9	5.189	72.95	0.059	54.79	0.742	-49.56
2.5	0.527	-61.63	4.979	70.13	0.062	53.59	0.741	-50.7
2.6	0.529	-62.78	4.816	68.35	0.064	53.44	0.743	-52
2.7	0.551	-67.21	4.839	66.22	0.072	52.3	0.768	-55.57
2.8	0.485	-70.76	4.649	60.62	0.072	47.22	0.715	-60.12
2.9	0.454	-71.28	4.382	57.65	0.074	44.14	0.68	-60.09
3	0.434	-70.94	4.207	55.39	0.072	42.21	0.666	-60.36
3.1	0.433	-67.82	4.048	54.44	0.068	41.81	0.669	-60.12
3.2	0.436	-66.18	3.936	52.8	0.069	43.96	0.674	-61.04
3.3	0.437	-68.3	3.847	50.72	0.072	47.68	0.684	-63.24
3.4	0.437	-72.51	3.81	48.36	0.078	46.81	0.687	-66.49
3.5	0.433	-73.15	3.767	45.48	0.082	45.71	0.676	-70.55

Table 14. Bypass Mode Scattering Parameters(V_{CC1} and V_{CC3} = 2.75 V, Band and Gain grounded, Enable = 2.75 V, Rbias resistor R1 = 1.2 kΩ, I_{CC} = 3 μA)

f (GHz)	S ₁₁		S ₂₁		S ₁₂		S ₂₂	
	S ₁₁	∠φ	S ₁₁	∠φ	S ₁₁	∠φ	S ₁₁	∠φ
0.7	0.556	-44.11	0.573	20.27	0.573	20.39	0.595	-42.94
0.8	0.514	-46.8	0.591	15.11	0.591	15.3	0.549	-43.78
0.9	0.475	-49.46	0.6	10.38	0.599	10.66	0.511	-43.02
1	0.459	-50.05	0.618	6.77	0.617	6.98	0.479	-46.66
1.1	0.427	-50.66	0.623	3.34	0.621	3.51	0.462	-47.17
1.2	0.412	-51.99	0.633	-0.34	0.632	-0.19	0.43	-49.25
1.3	0.391	-52.85	0.635	-3.09	0.634	-2.98	0.421	-49.35
1.4	0.379	-53.91	0.637	-6.45	0.636	-6.18	0.395	-50.53
1.5	0.368	-53.94	0.638	-8.92	0.638	-8.66	0.384	-51.37
1.6	0.358	-54.86	0.64	-11.49	0.639	-11.33	0.374	-52.64
1.7	0.352	-55.36	0.641	-14.09	0.64	-13.92	0.358	-53.9
1.8	0.346	-55.58	0.641	-16.37	0.641	-16.17	0.345	-54.87
1.9	0.341	-55.61	0.641	-18.68	0.641	-18.47	0.334	-56.07
2	0.334	-56.07	0.638	-20.97	0.639	-20.85	0.321	-56.45
2.1	0.329	-56.92	0.635	-23.12	0.633	-22.91	0.312	-56.2
2.2	0.319	-57.96	0.636	-24.75	0.636	-24.45	0.314	-57.47
2.3	0.308	-57.61	0.64	-26.81	0.64	-26.59	0.306	-59.76
2.4	0.299	-57.89	0.641	-29.13	0.64	-28.92	0.295	-61.28
2.5	0.293	-59.25	0.64	-31.4	0.642	-31.04	0.291	-62.5
2.6	0.285	-60.49	0.636	-33.55	0.636	-33.11	0.277	-62.84
2.7	0.279	-62.48	0.636	-35.59	0.635	-35.51	0.272	-65.72
2.8	0.274	-64.02	0.634	-37.84	0.633	-37.69	0.258	-67.26
2.9	0.267	-66.58	0.629	-39.74	0.63	-39.66	0.247	-67.95
3	0.27	-68.28	0.623	-42.19	0.623	-42.06	0.232	-68.55
3.1	0.264	-70.53	0.618	-43.48	0.616	-43.19	0.241	-64.77
3.2	0.261	-72.44	0.617	-45.42	0.616	-45.19	0.241	-69.24
3.3	0.26	-73.31	0.616	-47.61	0.615	-47.35	0.227	-74.2
3.4	0.26	-73.49	0.613	-49.49	0.613	-49.26	0.209	-76.39
3.5	0.265	-73.26	0.61	-52.15	0.61	-51.84	0.179	-78.56

Table 15. Noise Parameters $(V_{CC} = 2.7\text{ V}, \text{Enable} = 2.75\text{ V}, R_{\text{bias}} = 1.2\text{ k}\Omega, I_{CC} = 4.8\text{ mA})$

f (GHz)	NFmin (dB)	Gamma Opt		Rn (Ω)	rn (Ω)	G _{NF} (dB)	K
		Mag	Ang				
1	1.11	0.27	25.3	14	0.28	26.21	0.63
1.575	0.99	0.29	40.8	13	0.26	22.63	0.74
1.9	0.96	0.30	46.9	12.5	0.25	20.83	0.70
2.14	0.96	0.30	50.1	12.5	0.25	19.8	0.78
2.4	0.97	0.30	54.0	12	0.24	18.3	0.89

Table 16. Noise Parameters $(V_{CC} = 2.7\text{ V}, \text{Enable} = 2.75\text{ V}, R_{\text{bias}} = 2\text{ k}\Omega, I_{CC} = 2.8\text{ mA})$

f (GHz)	NFmin (dB)	Gamma Opt		Rn (Ω)	rn (Ω)	G _{NF} (dB)	K
		Mag	Ang				
1	1.16	0.23	27.6	15.5	0.31	26.09	0.48
1.575	1.02	0.35	39.0	15	0.3	22.57	0.56
1.9	0.97	0.37	46.2	14	0.28	20.81	0.53
2.14	0.96	0.37	49.7	14	0.28	19.79	0.61
2.4	0.95	0.37	54.1	13.5	0.27	18.3	0.77

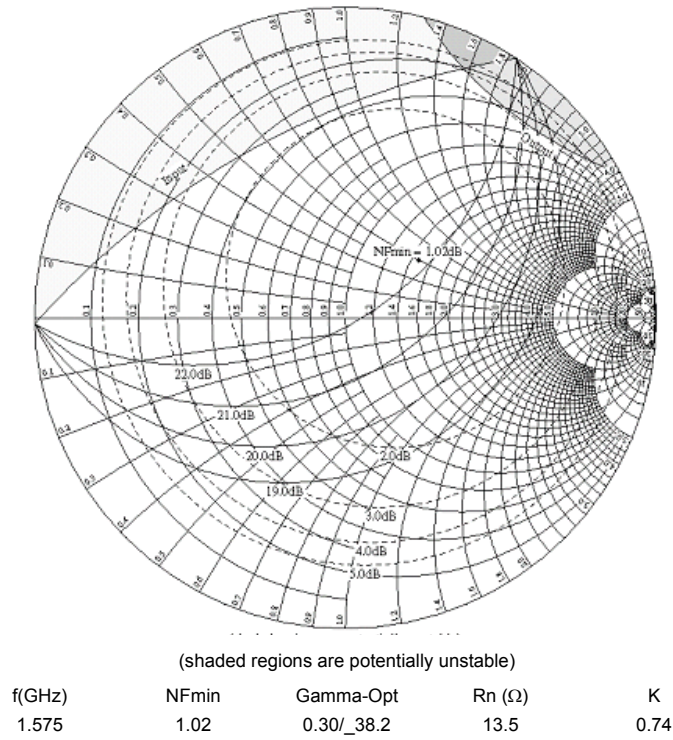

Figure 16. Constant Noise Figure and Gain Circles. 1575 MHz, Rbias = 1.2 k Ω

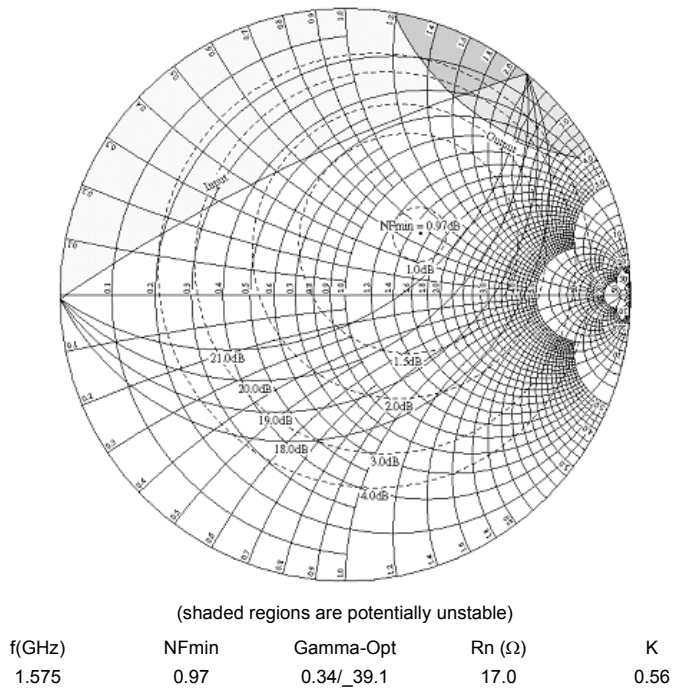

Figure 17. Constant Noise Figure and Gain Circles. 1575 MHz, Rbias = 2 k Ω

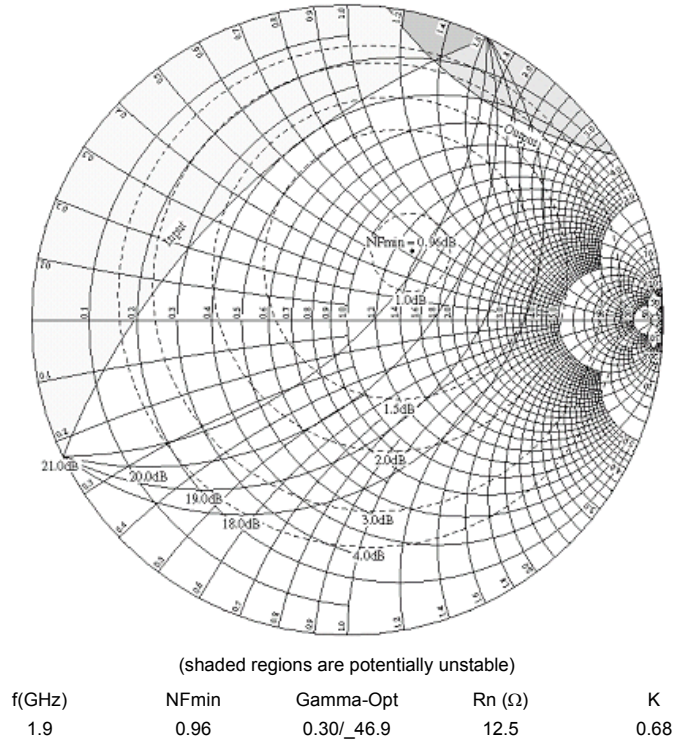

Figure 18. Constant Noise Figure and Gain Circles. 1900 MHz, Rbias =1.2 k Ω

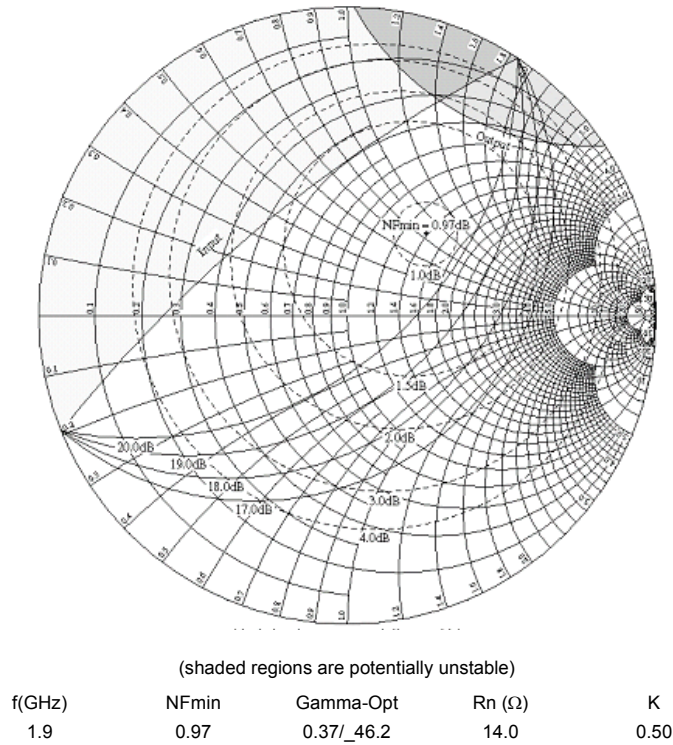
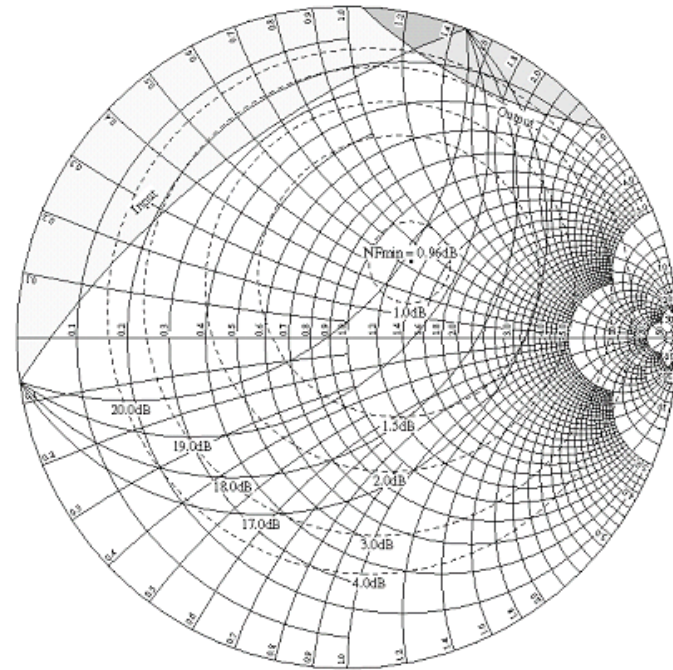

Figure 19. Constant Noise Figure and Gain Circles. 1900 MHz, Rbias = 2 k Ω



(shaded regions are potentially unstable)

f(GHz)	NFmin	Gamma-Opt	Rn (Ω)	K
2.1	0.96	0.30/_50.1	12.5	0.76

Figure 20. Constant Noise Figure and Gain Circles. 2140 MHz, Rbias =1.2 k Ω

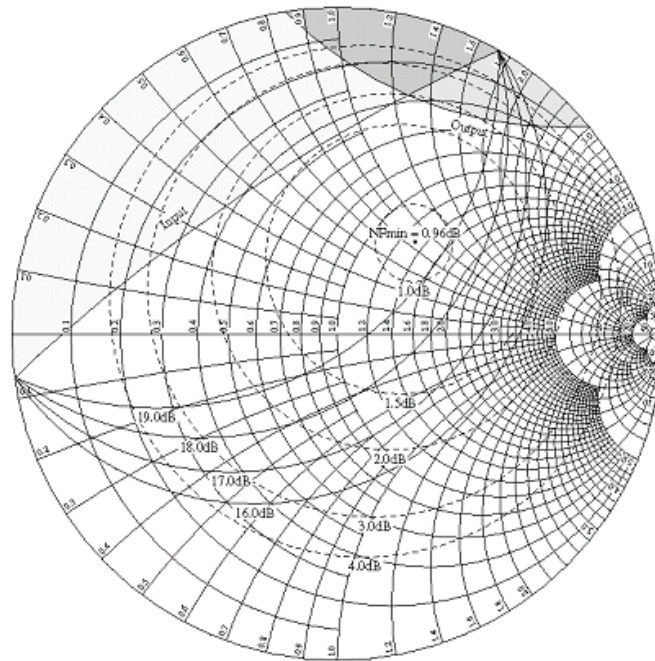

(shaded regions are potentially unstable)

f(GHz)	NFmin	Gamma-Opt	Rn (Ω)	K
2.1	0.96	0.37/_49.7	14.0	0.58

Figure 21. Constant Noise Figure and Gain Circles. 2140 MHz, Rbias =1.2 k Ω

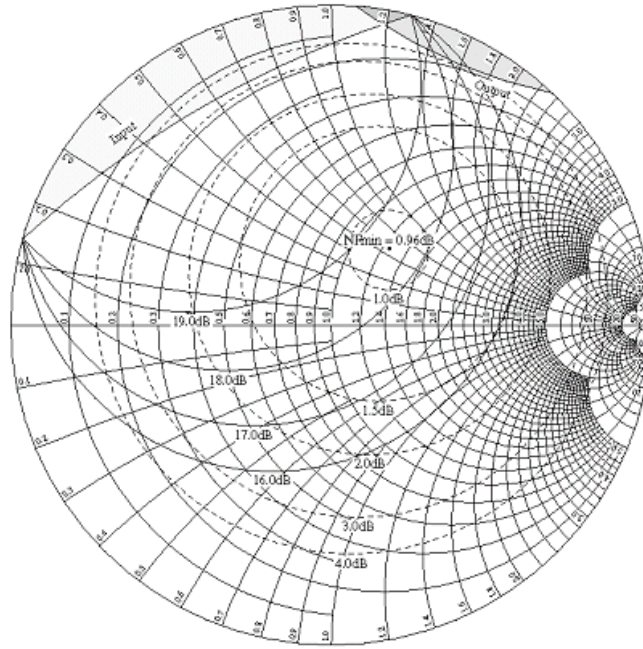

(shaded regions are potentially unstable)

f(GHz)	NFmin	Gamma-Opt	Rn (Ω)	K
2.3	0.96	0.30/_52.8	12.0	0.85

Figure 22. Constant Noise Figure and Gain Circles. 2400 MHz, Rbias = 1.2 k Ω

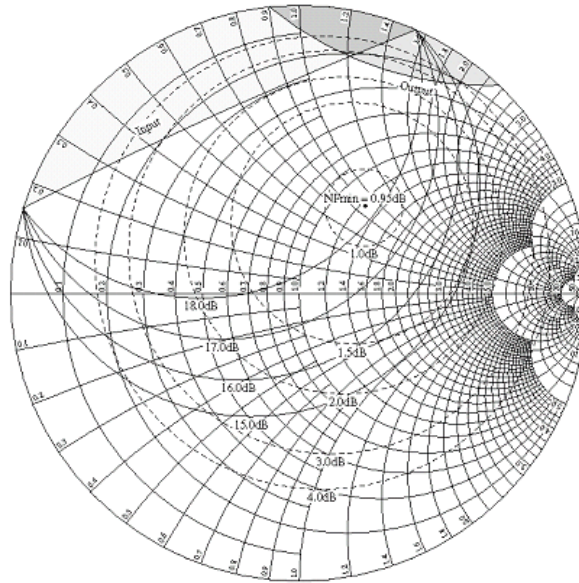

(shaded regions are potentially unstable)

f(GHz)	NFmin	Gamma-Opt	Rn (Ω)	K
2.3	0.95	0.38/_53	13.5	0.70

Figure 23. Constant Noise Figure and Gain Circles. 2400 MHz, Rbias = 2 k Ω

6 Packaging

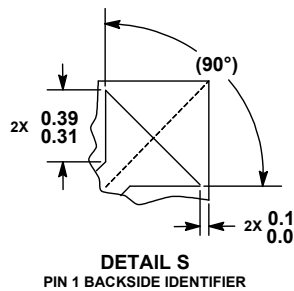
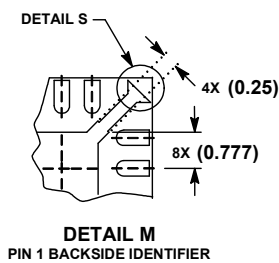
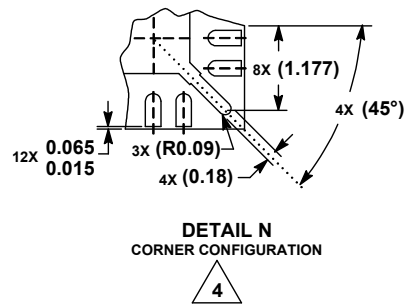
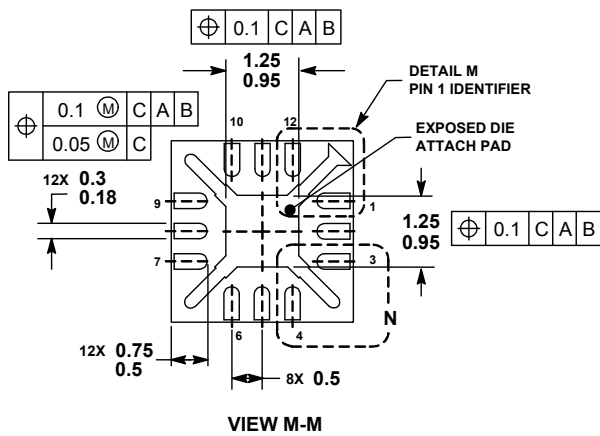
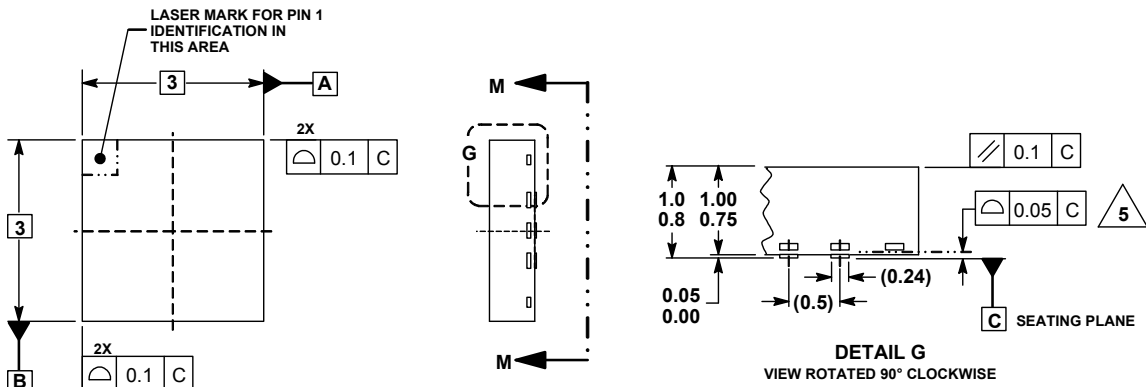

- NOTES:
1. DIMENSIONS ARE IN MILLIMETERS.
 2. INTERPRET DIMENSIONS AND TOLERANCES PER ASME Y14.5M, 1994.
 3. THE COMPLETE JEDEC DESIGNATOR FOR THIS PACKAGE IS: HF-PQFP-N.
 4. CORNER CHAMFER MAY NOT BE PRESENT. DIMENSIONS OF OPTIONAL FEATURES ARE FOR REFERENCE ONLY.
 5. COPLANARITY APPLIES TO LEADS, CORNER LEADS, AND DIE ATTACH PAD.

Figure 24. Outline Dimensions for QFN-12
(Case Outline 1345-01, Issue A)

7 Reference Documentation

This data sheet is labeled as a particular type: Product Preview, Advance Information, or Technical Data. Definitions of these types are available at: <http://www.freescale.com>.

8 Revision History

Table 17 summarizes revisions to this document since the previous release (Rev. 1.2).

Table 17. Revision History

Location	Revision
Table 4 , Table 6 , Table 7 , Table 8 , Table 9 , Table 10	Substantial changes to parameters in the tables listed at left.
Figure 12	Inserted new Figure 12, subsequent figures re-numbered.

How to Reach Us:

Home Page:
www.freescale.com

Web Support:
<http://www.freescale.com/support>

USA/Europe or Locations Not Listed:
Freescale Semiconductor
Technical Information Center, EL516
2100 East Elliot Road
Tempe, Arizona 85284
1-800-521-6274 or +1-480-768-2130
www.freescale.com/support

Europe, Middle East, and Africa:
Freescale Halbleiter Deutschland GmbH
Technical Information Center
Schatzbogen 7
81829 Muenchen, Germany
+44 1296 380 456 (English)
+46 8 52200080 (English)
+49 89 92103 559 (German)
+33 1 69 35 48 48 (French)
www.freescale.com/support

Japan:
Freescale Semiconductor Japan Ltd.
Headquarters
ARCO Tower 15F
1-8-1, Shimo-Meguro, Meguro-ku,
Tokyo 153-0064, Japan
0120 191014 or +81 3 5437 9125
support.japan@freescale.com

Asia/Pacific:
Freescale Semiconductor China Ltd
Exchange Building 23F
No. 118 Jianguo Road
Chaoyang District
Beijing 100022
China
+86 10 5879 8000
support.asia@freescale.com

For Literature Requests Only:
Freescale Semiconductor Literature Distribution Center
P.O. Box 5405
Denver, Colorado 80217
1-800-441-2447 or +1-303-675-2140
Fax: +1-303-675-2150
LDCForFreescaleSemiconductor@hibbertgroup.com

Information in this document is provided solely to enable system and software implementers to use Freescale Semiconductor products. There are no express or implied copyright licenses granted hereunder to design or fabricate any integrated circuits or integrated circuits based on the information in this document.

Freescale Semiconductor reserves the right to make changes without further notice to any products herein. Freescale Semiconductor makes no warranty, representation or guarantee regarding the suitability of its products for any particular purpose, nor does Freescale Semiconductor assume any liability arising out of the application or use of any product or circuit, and specifically disclaims any and all liability, including without limitation consequential or incidental damages. "Typical" parameters that may be provided in Freescale Semiconductor data sheets and/or specifications can and do vary in different applications and actual performance may vary over time. All operating parameters, including "Typicals", must be validated for each customer application by customer's technical experts. Freescale Semiconductor does not convey any license under its patent rights nor the rights of others. Freescale Semiconductor products are not designed, intended, or authorized for use as components in systems intended for surgical implant into the body, or other applications intended to support or sustain life, or for any other application in which the failure of the Freescale Semiconductor product could create a situation where personal injury or death may occur. Should Buyer purchase or use Freescale Semiconductor products for any such unintended or unauthorized application, Buyer shall indemnify and hold Freescale Semiconductor and its officers, employees, subsidiaries, affiliates, and distributors harmless against all claims, costs, damages, and expenses, and reasonable attorney fees arising out of, directly or indirectly, any claim of personal injury or death associated with such unintended or unauthorized use, even if such claim alleges that Freescale Semiconductor was negligent regarding the design or manufacture of the part.

Freescale™ and the Freescale logo are trademarks of Freescale Semiconductor, Inc. All other product or service names are the property of their respective owners.

© Freescale Semiconductor, Inc. 2005–2008. All rights reserved.

RoHS-compliant and/or Pb-free versions of Freescale products have the functionality and electrical characteristics of their non-RoHS-compliant and/or non-Pb-free counterparts. For further information, see <http://www.freescale.com> or contact your Freescale sales representative.

For information on Freescale's Environmental Products program, go to <http://www.freescale.com/epp>.