

Silicon epitaxial planer type

Features

- Plastic package has Underwriters Laboratory Flammability Classification 94V-0 Utilizing Flame Retardant Epoxy Molding Compound.
- For surface mounted applications.
- Exceeds environmental standards of ML-S-19500 / 228
- Low leakage current

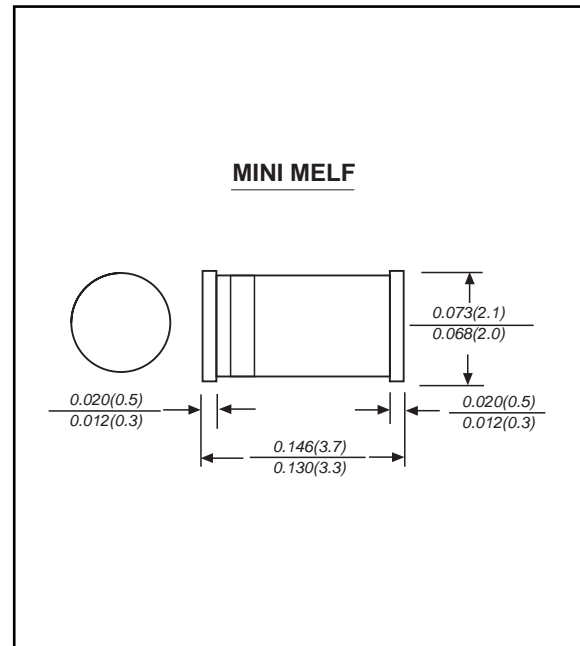

Mechanical data

Case : Molded plastic, MINI-MELF
 Terminals : Solder plated, solderable per ML-STD-750,
 Method 2026
 Polarity : Indicated by cathode band
 Mounting Position : Any
 Weight : 0.015 gram

MAXIMUM RATINGS (AT $T_A=25^\circ\text{C}$ unless otherwise noted)

PARAMETER	CONDITIONS	Symbol	MIN.	TYP.	MAX.	UNIT
Forward rectified current	See Fig.2	I_O			1.0	A
Forward surge current	8.3ms single half sine-wave superimposed on rate load (JEDEC methode)	I_{FSM}			25	A
Reverse current	$V_R = V_{RRM} T_A = 25^\circ\text{C}$	I_R			1.0	mA
	$V_R = V_{RRM} T_A = 100^\circ\text{C}$				10	mA
Thermal resistance	Junction to ambient	R_{QJA}		80		$^\circ\text{C} / \text{w}$
Diode junction capacitance	$f=1\text{MHz}$ and applied 4vDC reverse voltage	C_J		110		pF
Storage temperature		T_{STG}	-55		+150	$^\circ\text{C}$

SYMBOLS	MARKING CODE	V_{RRM}^{*1} (V)	V_{RMS}^{*2} (V)	V_R^{*3} (V)	V_F^{*4} (V)	Operating temperature ($^\circ\text{C}$)
SM5817	-	20	14	20	0.45	-55 to +125
SM5818	-	30	21	30	0.55	
SM5819	-	40	28	40	0.60	

*1 Repetitive peak reverse voltage

*2 RMS voltage

*3 Continuous reverse voltage

*4 Maximum forward voltage

RATING AND CHARACTERISTIC CURVES (SM5817 THRU SM5819)

FIG.1-TYPICAL FORWARD CHARACTERISTICS

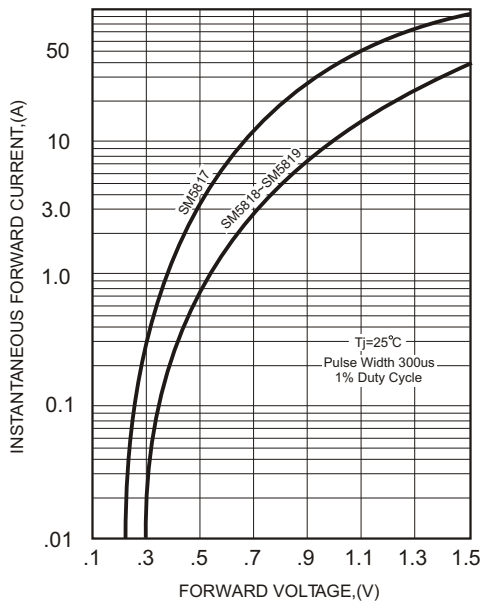

FIG.2-TYPICAL FORWARD CURRENT DERATING CURVE

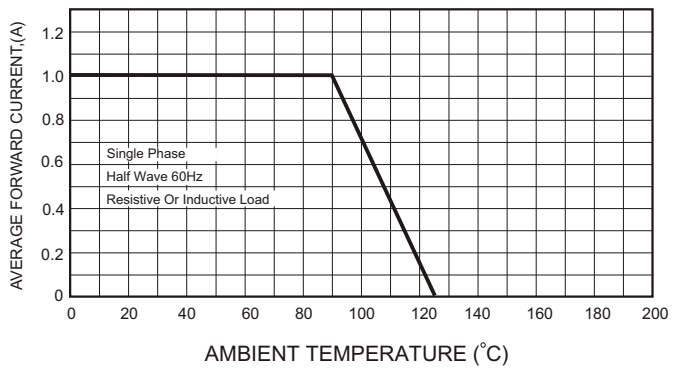

FIG.4-MAXIMUM NON-REPETITIVE FORWARD SURGE CURRENT

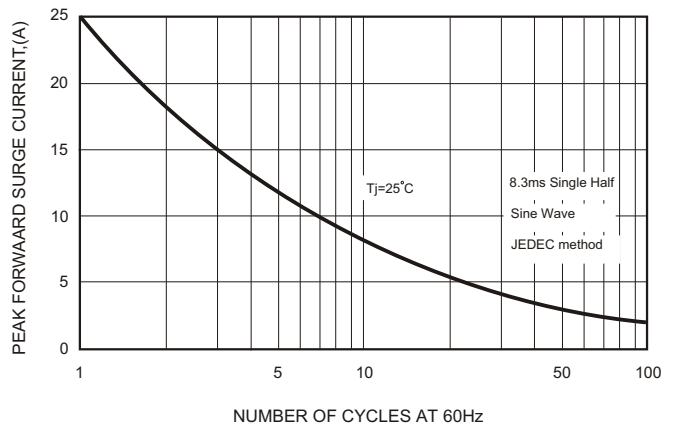

FIG.3 - TYPICAL REVERSE CHARACTERISTICS

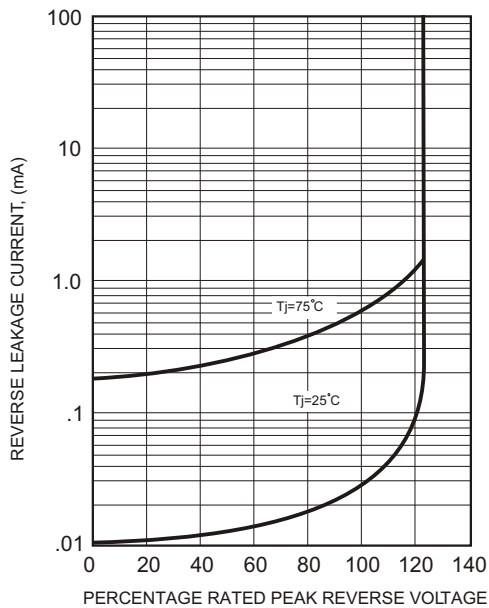

FIG.5-TYPICAL JUNCTION CAPACITANCE

