

AN-6607

The Noise Figure Fallacy

Noise Figure (NF) can be one of the most misleading specifications confronting the engineer today. Noise Figure is defined as the ratio of total output noise power to the output noise power of the source.

$$NF = 10 \text{ Log} \frac{\text{Total output noise power}}{\text{Output noise power of the source}} \quad (1)$$

A minimum NF exists for any amplifier, but is usually far removed from the actual operating conditions. This is where the problem begins. Lowering the NF doesn't always lower the noise which is what the engineer is really interested in. NF only gives the designer insight into the ratio of the amplifier noise to the source noise, not the input noise of the amplifier or the signal to noise ratio.

Amplifier noise performance is adequately described by modeling the noise sources as a series voltage generator and a shunt current generator with a series voltage generator for the source resistance noise.

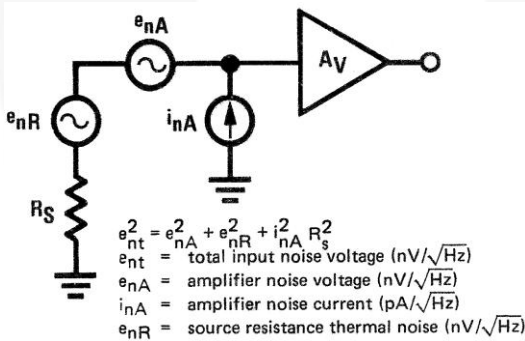

Figure 1. Simplified Amplifier Noise Model

The amplifier noise data is found on vendor data sheets in the form of e_n and i_n vs. frequency for bipolar transistors and e_n vs. frequency for FETs and FET amplifiers.

Current noise depends on amplifier input bias current which is only a few pico-amps for FETs and is therefore negligible. However, bipolar transistor amplifiers have bias currents into the micro-amp range where current noise is significant.

The thermal noise of the source resistance is given by Nyquist's relation.



$$\overline{V_R^2} = 4kTR\Delta f \quad (2)$$

$\overline{V_R^2}$ = mean square noise voltage (V^2)
 k = Boltzmann constant (1.38×10^{-23} VAS/ $^\circ\text{K}$)
 T = absolute temperature ($^\circ\text{K}$)
 R = resistance (Ω)
 Δf = noise bandwidth (Hz)

With the spectral density given by e_n^2 :

$$e_{nR} = (\overline{V_R^2}/\Delta f)^{1/2} \quad (3)$$

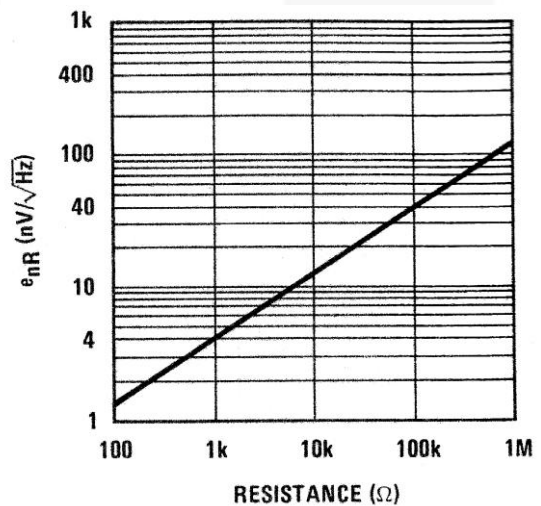

Figure 2. Thermal Noise vs. Resistance

Using the model of Figure 1, an expression of noise figure in terms of the noise generators can be developed.

The noise power of the source can be found by using Nyquist's relation.

$$\text{Source Noise Power} = \frac{\overline{V_R^2}}{R^2} = \frac{e_{nR}^2 \Delta f}{R^2} \quad (2)$$

With the total output noise power at the input of the amplifier of:

$$\text{Total noise power} = \frac{e_{nR}^2 \Delta f}{R^2} + \frac{e_{nA}^2 \Delta f}{R^2} + i_{nA}^2 R^2 \Delta f \quad (3)$$

Yielding

$$\text{NF} = 10 \text{ Log} \left[1 + \frac{e_{nA}^2 + i_{nR}^2 R^2}{e_{nR}^2} \right] \quad (4)$$

Noise Figure has a minimum that occurs at an optimum source resistance R_{opt} .

$$R_{opt} = \frac{e_{nA}}{i_{nA}} \quad (5)$$

Artificially changing the source resistance for minimum NF generally increases the circuit noise as demonstrated by the following example.

Example:

An amplifier is needed to boost the signal from a resistive transducer.

Amplifier requirements

$A_v = 100$
 $f = 10 \text{ Hz to } 10 \text{ kHz}$
 Transducer = $10 \text{ k}\Omega$

Amplifier—LF356

Noise data, $e_n = 12 \text{ nV}/\sqrt{\text{Hz}} @ 1 \text{ kHz}$
 $i_n = 0.01 \text{ pA}/\sqrt{\text{Hz}} @ 1 \text{ kHz}$

The optimum source resistance for the amplifier is found to be 12M (using equation (5)). Using Figure 2, the noise of the transducer is $12 \text{ nV}/\sqrt{\text{Hz}}$ and the noise of the optimum source resistance is $140 \text{ nV}/\sqrt{\text{Hz}}$.

Using the non-inverting amplifier configuration, we'll view the effect of R_{opt} . In one case, resistance is added to the source to equal the amplifier optimum source resistance (not affecting gain). The other case only has the transducer connected to the input.

We will neglect the noise of the feedback resistors and determine the input noise and NF for both configurations using equations (1)—(4).

Case A, minimum NF

$$\begin{aligned} \text{Total input noise} \\ V_n &= e_{nt} (\Delta f)^{1/2} = 14 \mu\text{V} \\ \text{NF} &= 0.06 \text{ dB} \end{aligned}$$

Case B, minimum noise

$$\begin{aligned} V_n &= 1.7 \mu\text{V} \\ \text{NF} &= 3 \text{ dB} \end{aligned}$$

Noise figure is only a measurement of the amplifier noise relative to the source noise. The example used was radical, but it illustrated a very important point. Resistance should never be added in series with the source to improve the NF. The NF improves but the input noise suffers, degrading performance. Total input noise should always be considered allowing problem sources to be identified and minimized to meet the system's specific noise requirements. Figure 3 and Figure 4 provide examples of minimum noise figure and minimum noise amplifiers.

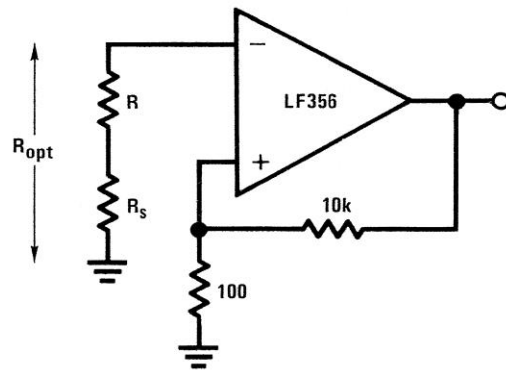

Figure 3. Minimum Noise Figure Amplifier

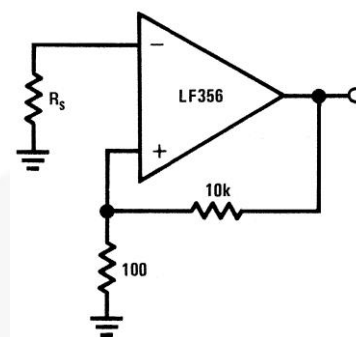

Figure 4. Minimum Noise Amplifier

Author: John Maxwell, February 1977.

DISCLAIMER

FAIRCHILD SEMICONDUCTOR RESERVES THE RIGHT TO MAKE CHANGES WITHOUT FURTHER NOTICE TO ANY PRODUCTS HEREIN TO IMPROVE RELIABILITY, FUNCTION, OR DESIGN. FAIRCHILD DOES NOT ASSUME ANY LIABILITY ARISING OUT OF THE APPLICATION OR USE OF ANY PRODUCT OR CIRCUIT DESCRIBED HEREIN; NEITHER DOES IT CONVEY ANY LICENSE UNDER ITS PATENT RIGHTS, NOR THE RIGHTS OF OTHERS.

LIFE SUPPORT POLICY

FAIRCHILD'S PRODUCTS ARE NOT AUTHORIZED FOR USE AS CRITICAL COMPONENTS IN LIFE SUPPORT DEVICES OR SYSTEMS WITHOUT THE EXPRESS WRITTEN APPROVAL OF THE PRESIDENT OF FAIRCHILD SEMICONDUCTOR CORPORATION.

As used herein:

1. Life support devices or systems are devices or systems which, (a) are intended for surgical implant into the body, or (b) support or sustain life, or (c) whose failure to perform when properly used in accordance with instructions for use provided in the labeling, can be reasonably expected to result in significant injury to the user.
- 2.
3. A critical component is any component of a life support device or system whose failure to perform can be reasonably expected to cause the failure of the life support device or system, or to affect its safety or effectiveness.