



TDA2822H

LINEAR INTEGRATED CIRCUIT

DUAL LOW VOLTAGE POWER AMPLIFIER

■ DESCRIPTION

The UTC **TDA2822H** is a monolithic integrated audio amplifier in a 8-Pin plastic dual in line package. It is designed for portable cassette players and radios.

■ FEATURES

- *Wide operating supply voltage: $V_{CC}=1.8V\sim 6V$.
- *Low crossover distortion.
- *Low quiescent circuit current.
- *Bridge/stereo configuration.

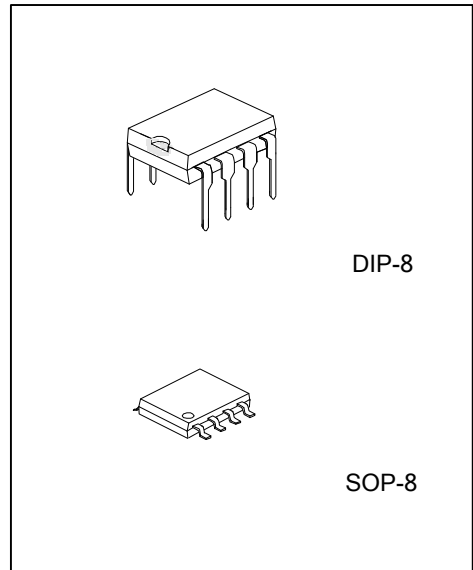

■ ORDERING INFORMATION

Order Number		Package	Packing
Lead Free	Halogen Free		
TDA2822HL-D08-T	TDA2822HG-D08-T	DIP-8	Tube
TDA2822HL-S08-T	TDA2822HG-S08-T	SOP-8	Tube
TDA2822HL-S08-R	TDA2822HG-S08-R	SOP-8	Tape Reel

<p>TDA2822HL-D08-T</p> <p>(1) Packing Type</p> <p>(2) Package Type</p> <p>(3) Lead Free</p>	<p>(1) T: Tube, R: Tape Reel</p> <p>(2) D08: DIP-8, S08: SOP-8</p> <p>(3) L: Lead Free, G: Halogen Free</p>
---	---

■ PIN CONFIGURATION

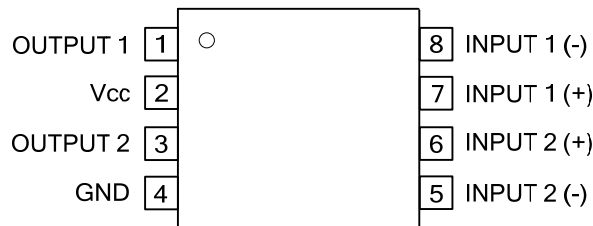

■ PIN DESCRIPTION

PIN NO	PIN NAME	DESCRIPTION
1	OUTPUT 1	Output of Channel 1
2	V _{CC}	Supply Voltage
3	OUTPUT 2	Output of Channel 2
4	GND	Ground.
5	INPUT 2(-)	Inverting Input of Channel 2
6	INPUT 2(+)	Non-Inverting Input of Channel 2
7	INPUT 1 (+)	Non-Inverting Input of Channel 1
8	INPUT 1 (-)	Inverting Input of Channel 1

■ BLOCK DIAGRAM

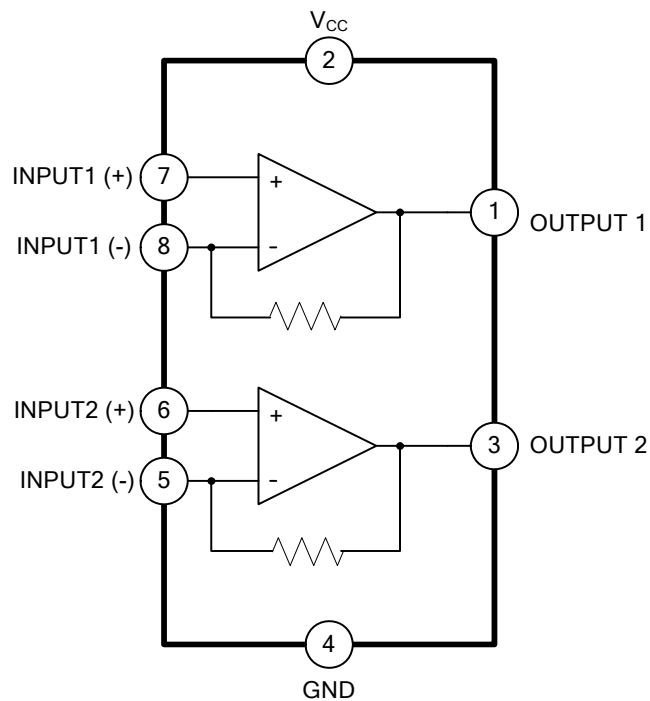

■ ABSOLUTE MAXIMUM RATINGS ($T_A=25^\circ\text{C}$, unless otherwise specified)

PARAMETER		SYMBOL	RATINGS	UNIT
Supply Voltage		V_{CC}	15	V
Output Peak Current		$I_{O(\text{peak})}$	1	A
Power Dissipation	$T_A=50^\circ\text{C}$	P_D	1.0	W
	$T_C=50^\circ\text{C}$		1.4	W
	$T_A=50^\circ\text{C}$		0.5	W
Operating Temperature		T_{OPR}	-20~+85	$^\circ\text{C}$
Storage Temperature		T_{STG}	-40 ~ +150	$^\circ\text{C}$

■ ELECTRICAL CHARACTERISTICS ($T_A=25^\circ\text{C}$, $V_{CC}=4.5\text{V}$, BTL parameter, unless otherwise specified)

PARAMETER	SYMBOL	TEST CONDITIONS		MIN	TYP	MAX	UNIT	
Operating Supply Voltage	V_{CC}			1.8		6	V	
Quiescent Circuit Current	I_{CCQ}	$R_L=\infty$			9		mA	
Output Offset Voltage	V_{OS}	$R_L=8\Omega$				± 50	mV	
Input Base Current	I_B				100		nA	
Output Power	P_O	$f=1\text{kHz}$, THD=10%	$R_L=32\Omega$	$V_{CC}=6\text{V}$	300	320	mW	
				$V_{CC}=4.5\text{V}$		200		
				$V_{CC}=3\text{V}$	50	65		
				$V_{CC}=2\text{V}$		8		
			$R_L=16\Omega$	$V_{CC}=6\text{V}$		600		
				$V_{CC}=3\text{V}$		120		
			$R_L=8\Omega$	$V_{CC}=4.5\text{V}$		700		
				$V_{CC}=3\text{V}$		220		
$R_L=4\Omega$	$V_{CC}=3\text{V}$	200	350					
Total Harmonic Distortion	THD	$P_O=0.5\text{W}$, $R_L=8\Omega$, $P_O=1\text{kHz}$			0.2		%	
Closed Loop Voltage Gain	A_{VF}	$f=1\text{kHz}$			39		dB	
Input Resistance	Z_{IN}	$f=1\text{kHz}$		100			k Ω	
Total Input Noise	e_N	$R_S=10\text{k}\Omega$	$B=22\text{Hz} \sim 22\text{kHz}$		3		μV	
Supply Voltage Rejection	SVR	$f=100\text{Hz}$			40		dB	
Power Bandwidth	BWp	$R_L=8\Omega$, $P_O=1\text{W}$			120		kHz	

■ APPLICATION CIRCUIT

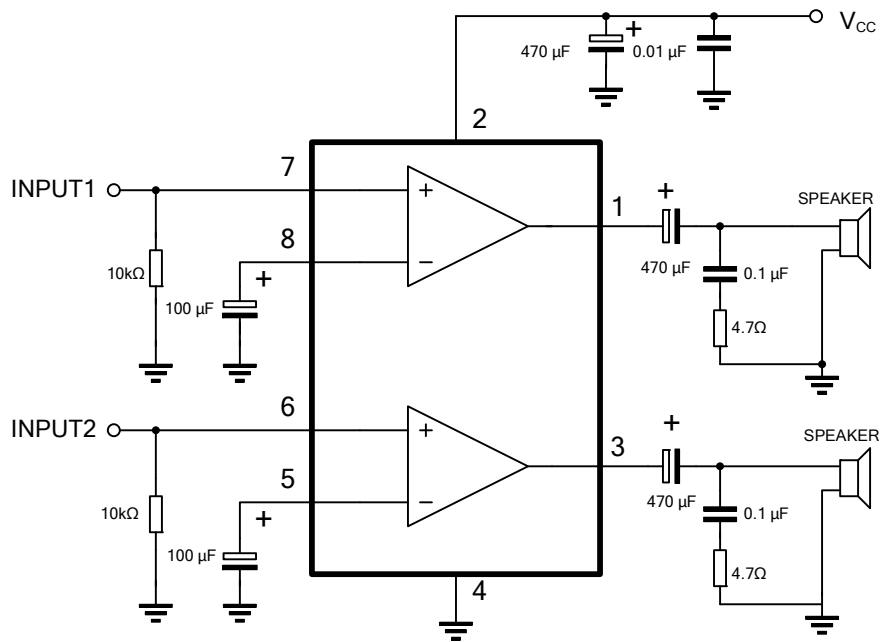

Fig 1. STEREO

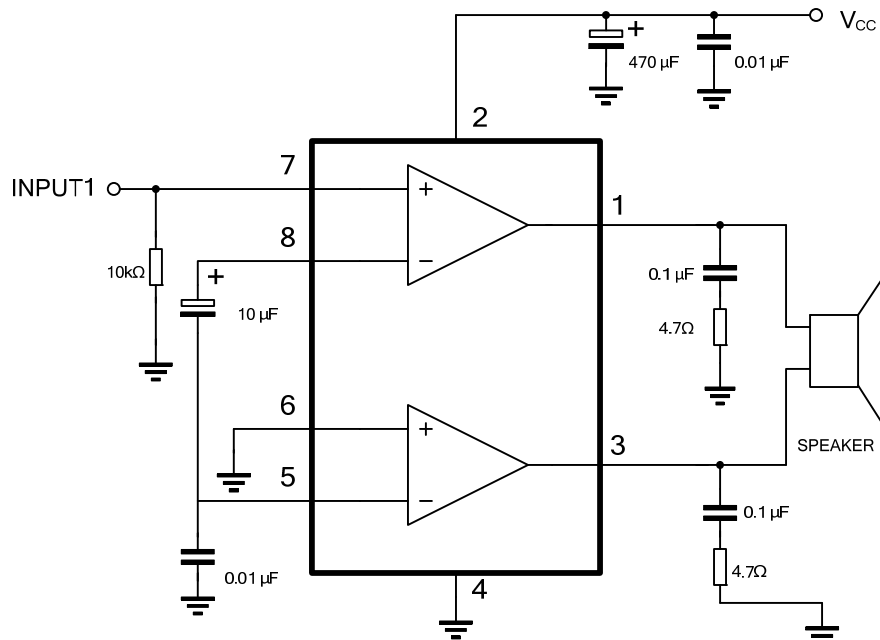

Fig 2. BRIDGE

UTC assumes no responsibility for equipment failures that result from using products at values that exceed, even momentarily, rated values (such as maximum ratings, operating condition ranges, or other parameters) listed in products specifications of any and all UTC products described or contained herein. UTC products are not designed for use in life support appliances, devices or systems where malfunction of these products can be reasonably expected to result in personal injury. Reproduction in whole or in part is prohibited without the prior written consent of the copyright owner. The information presented in this document does not form part of any quotation or contract, is believed to be accurate and reliable and may be changed without notice.