

**PROPER USE GUIDELINES**

Cumulative Trauma Disorders can result from the prolonged use of manually powered hand tools. Hand tools are intended for occasional use and low volume applications. A wide selection of powered application equipment for extended-use, production operations is available.

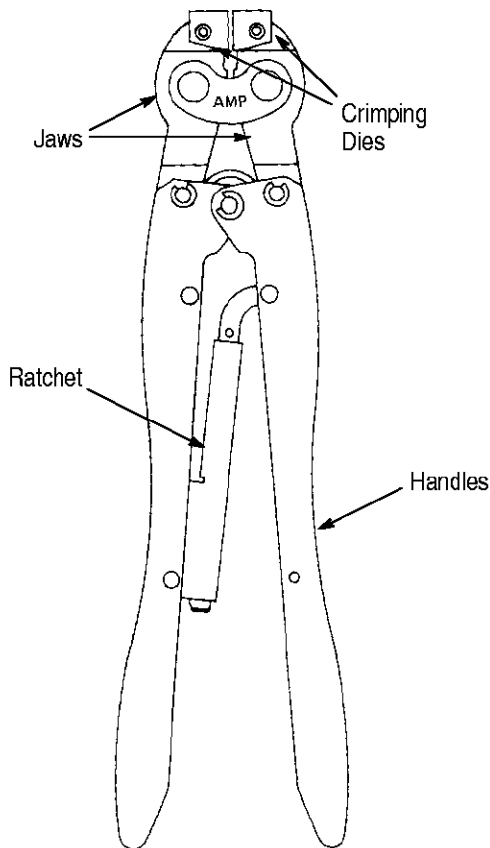

**1. INTRODUCTION**

TERMI-FOIL Heavy-Duty Hand Crimping Tool 68064 is designed to crimp the tab end of TERMI-FOIL terminals and splices (reference part numbers are listed in Figure 1) onto foil with a maximum thickness of 0.76 mm [.020 in.]. This tool is a member of the CERTI-CRIMP\* hand crimping tool family. The ratchet on these tools ensures full crimping of the product. Once engaged, the ratchet will not release until the handles have been FULLY closed.

**NOTE** All dimensions on this document are in metric units [with U.S. customary units in brackets].

Reasons for reissue of this instruction sheet are provided in Section 6, REVISION SUMMARY.

**2. DESCRIPTION**

The tool consists of two handles, a ratchet, and two jaws each with a crimping die. The crimping dies have flat faces which squeeze the lance-faced tab end of the terminal or splice into the foil.

**CAUTION** The dies bottom before the ratchet releases. DO NOT re-adjust the ratchet.

**3. CRIMPING PROCEDURE**

**NOTE** Depending on the foil and the terminal configuration, it may be necessary to crimp the wire barrel before crimping the tab end. See Figure 2 for wire-to-tooling cross-reference for crimping the wire barrel. The applicable wire size range is stamped on the product package label. For information on using the tooling, refer to the instructions packaged with the tooling.

**3.1. Double-Face Terminal or Splice**

1. Open tool handles FULLY.
2. Place the foil between faces of the tab end of terminal or splice, and squeeze the faces together manually. See Figure 3, Detail A.
3. Place the tab end and foil between the crimping dies as shown in Figure 3, Detail B. Make sure that the tab end is completely covered by the dies. DO NOT place the wire barrel between the dies.
4. Close the tool handles until the ratchet releases, then allow handles to open freely.

**CAUTION** DO NOT CONTINUE TO SQUEEZE THE TOOL HANDLES AFTER THE RATCHET RELEASES. Damage will occur to the tool if the ratchet is forced against the stop pin.

**TERMI-FOIL TERMINAL AND SPLICE**

TYPE	PART NUMBER	MATERIAL AND FINISH
Double-Face Terminal	329860	Nickel-Plated Copper
	330003	Tin-Plated Copper
Flag Terminal	52584	Tin-Plated Copper
Splice	51943	Tin-Plated Copper (Unannealed)
	329656	Tin-Plated Copper

Figure 1

**NOTE** A complete list of current terminal and splice part numbers cannot be maintained on this document. For all part numbers and their description, refer to Catalog 82039 or contact PRODUCT INFO at the number at the bottom of this page.

WIRE SIZE RANGE (AWG)	HAND TOOL	CRIMP HEAD	
		PNEUMATIC TOOL 69010	PNEUMATIC TOOL 69005
22-16	69997	NA	NA
16-14	49935	300583	300454
12-10	49935	300583	300454
8	69355	38394	300454

Figure 2

- Remove the crimped terminal or splice from the tool.
- For long-tongued terminals, several crimps will be necessary. These crimps should overlap to ensure that the entire tab end is crimped.
- For terminals, crimp the wire barrel using the appropriate tooling (refer to Figure 2) according to the instructions packaged with the tooling.

**Double-Face Terminal or Splice**

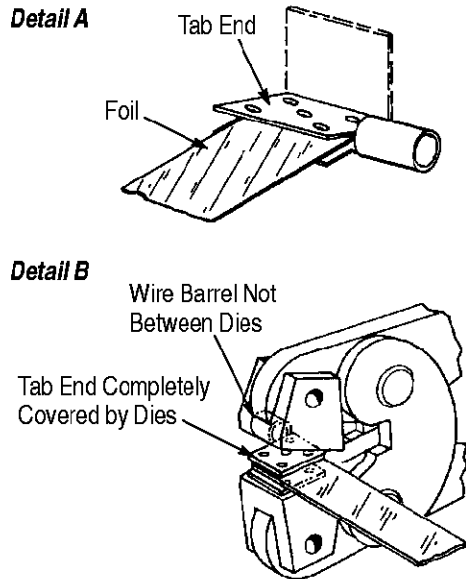

Figure 3

**3.2. Flag Terminal**

- Open tool handles FULLY.
- Place the tab end of the terminal between the crimping dies as shown in Figure 4, Detail A. Make sure that the tab end is completely covered by the dies. DO NOT place the wire barrel between the dies.
- Place the foil between faces of the tab end of terminal. See Figure 4, Detail B.

- Close the tool handles until the ratchet releases, then allow handles to open freely.

**CAUTION**

DO NOT CONTINUE TO SQUEEZE THE TOOL HANDLES AFTER THE RATCHET RELEASES. Damage will occur to the tool if the ratchet is forced against the stop pin.

- Remove the crimped terminal from the tool.
- For long-tongued terminals, several crimps will be necessary. These crimps should overlap to ensure that the entire tab end is crimped.
- Crimp the wire barrel using the appropriate tooling (refer to Figure 2) according to the instructions packaged with the tooling.

**Flag Terminal**

**Detail A**

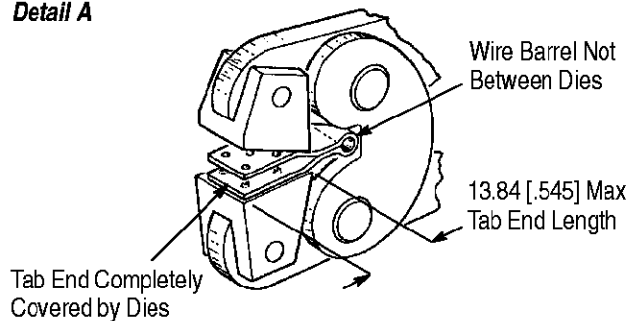

**Detail B**

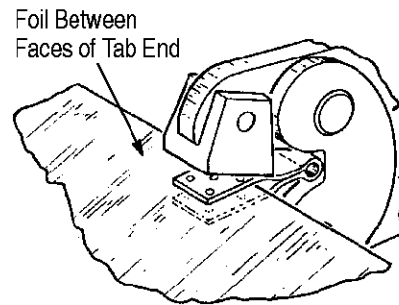

Figure 4

**4. INSPECTION AND MAINTENANCE**

**4.1. Daily Maintenance**

It is recommended that each operator of the tool be made aware of—and responsible for—the following steps of daily maintenance:

- Remove dust, moisture, and other contaminants with a clean brush or a soft, lint-free cloth. DO NOT use objects that could damage the tool.
- Make sure the proper retaining pins are in place and secured with the proper retaining rings.
- Make certain all pins, pivot points, and bearing surfaces are protected with a THIN coat of any good SAE 20 motor oil. DO NOT oil excessively.

4. When the tool is not in use, keep the handles closed to prevent objects from becoming lodged in the crimping dies. Store the tool in a clean, dry area.

**4.2. Periodic Inspection**

Regular inspections should be performed by quality control personnel. A record of scheduled inspections should remain with the tool and be supplied to personnel responsible for the tool. Though recommendations call for at least one inspection a month, the inspection frequency should be based on the amount of use, ambient working conditions, operator training and skill, and established company standards. These inspections should be performed in the following sequence:

**A. Visual Inspection**

1. Remove all lubrication and accumulated film by immersing the tool (handles partially closed) in a suitable commercial degreaser that will not affect paint or plastic material.
2. Make certain all retaining pins are in place and secured with retaining rings. If replacements are necessary, refer to Section 5, REPLACEMENT AND REPAIR.
3. Close the tool handles until the ratchet releases, then allow handles to open freely. If they do not open quickly and fully, the spring is defective and must be replaced. See Section 5, REPLACEMENT AND REPAIR.

**CAUTION** DO NOT CONTINUE TO SQUEEZE THE TOOL HANDLES AFTER THE RATCHET RELEASES. Damage will occur to the tool if the ratchet is forced against the stop pin.

4. Inspect the head assembly, with special emphasis on checking for worn, cracked, or broken jaws. If damage to any part of the head assembly is evident, the tool must be evaluated and repaired. See Section 5, REPLACEMENT AND REPAIR.

**B. Jaw Closure Inspection**

This inspection requires the use of a plug gage conforming to the dimensions in Figure 5. Proceed as follows:

1. Knock out the roll pins securing dies to jaws, then remove dies.
2. Close the tool handles to the last notch on the ratchet (the handles will automatically open if they are closed beyond this point).
3. Align the GO element with the tool jaws. Push the GO element straight into the jaw closure without using force. The GO element must pass completely through the jaw closure as shown in Figure 5.

4. Align the NO-GO element with the jaw closure and try to insert it into the jaw closure. The NO-GO element may start entry but must not pass completely through the jaw closure as shown in Figure 5.

5. Re-install the dies and secure them with the roll pins.

If the jaw closure conforms to the gage inspection, the tool is considered dimensionally correct and should be lubricated with a THIN coat of any good SAE 20 motor oil. If not, the tool must be repaired before returning it to service (see Section 5, REPLACEMENT AND REPAIR).

**C. Ratchet Inspection**

This inspection requires the use of a plug gage conforming to the dimensions in Figure 5. Proceed as follows:

1. Knock out the roll pins securing dies to jaws, remove dies, then insert the NO-GO element between tool jaws.

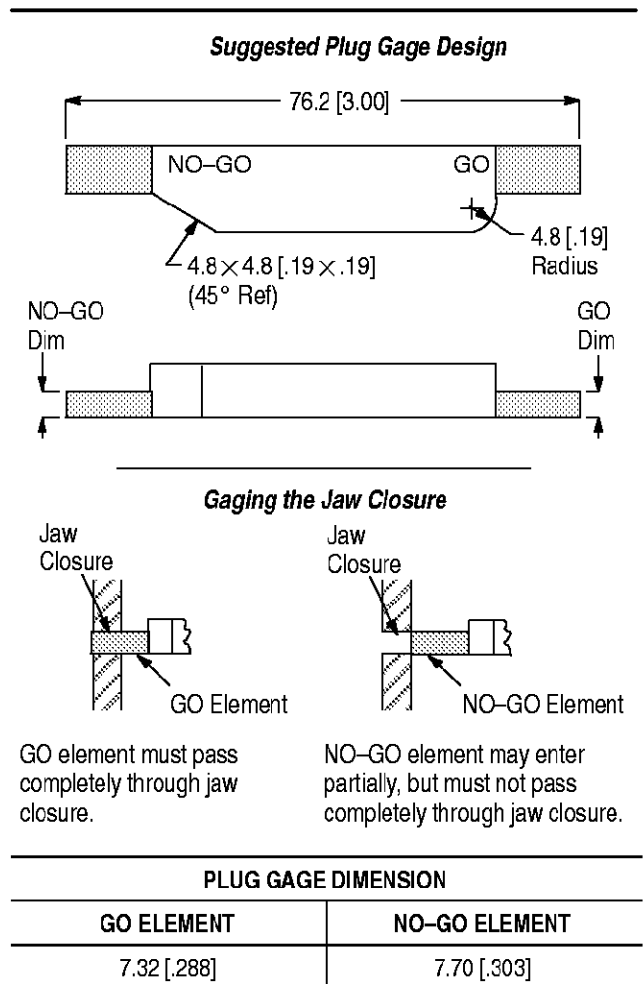

Figure 5

2. Close the tool handles until the ratchet releases then allow handles to open freely, and observe the following:

- a. Handles open before the ratchet hits the dowel pin.
- b. Jaws grasp the NO-GO element.

If above conditions are met, the ratchet is performing satisfactorily. If not, see Section 5, REPLACEMENT AND REPAIR.

3. Re-install the dies, and secure them with the roll pins.

**5. REPLACEMENT AND REPAIR**

Customer-replaceable parts are listed in Figure 6. A complete inventory should be stocked and controlled to prevent lost time when replacement of parts is necessary. Parts other than those listed should be replaced by Tyco Electronics to ensure quality and reliability. Order replacement parts through your representative, or call 1-800-526-5142,

or send a facsimile of your purchase order to 717-986-7605, or write to:

CUSTOMER SERVICE (038-035)  
TYCO ELECTRONICS CORPORATION  
PO BOX 3608  
HARRISBURG PA 17105-3608

For customer repair service, contact a representative at 1-800-526-5136.

**6. REVISION SUMMARY**

Revisions to this instruction sheet per EC 0990-1177-02 include:

- Updated document to corporate requirements
- Added list of reference product part numbers
- Replaced reference to CERTI-CRIMP\* ratchet with ratchet
- Added CAUTION to Section 2, and Paragraphs 3.1, 3.2, and 4.2
- Changed 'roll pin' to 'dowel pin' in Step 2 of Paragraph 4.2,C
- Changed address for customer repair service to telephone number in Section 5
- Corrected quantity per tool for Items 1, 3, 6, and 7 in Figure 6
- Changed Items 5 and 7 in Figure 6

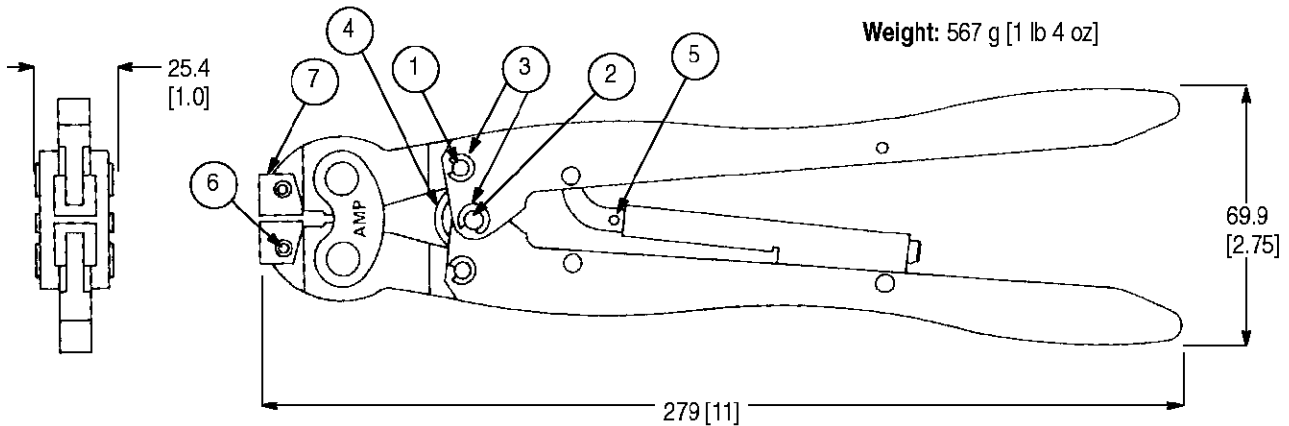

**REPLACEMENT PARTS**

ITEM	PART NUMBER	DESCRIPTION	QTY PER TOOL
1	38459	PIN, Retaining	2
2	2-23620-9	PIN, Retaining	1
3	21045-6	RING, Retaining	6
4	39364	SPRING	1
5	1-21919-1	PIN, Dowel	1
6	6-21028-8	PIN, Roll	2
7	305956-8	ANVIL, Die	2

Figure 6