



MEA-868-915-SMA

868MHz-915MHz ISM band antenna

Part #: 100-00153-01



Description

The MEA-868-915 is a high efficient wide band antenna 868MHz & 915MHz ISM band applications. This antenna was designed for LoRa & Sigfox IOT applications. The high efficiency and high gain design provide the antenna consistent and stable connectivity. The antenna housing consists of black UV resistant plastic, IP 67 rated housing, and a heavy duty metal base for optimal installations. The customizable cable and connector along with the overall high performance and low profile make this antenna the leader in the industry.

Electrical Specifications

Parameter	Specification
Frequency Range	868-915 MHz
Gain	3 dBi
V.S.W.R	≤ 2.5
Radiation	Omni-Directional
Polarization	Vertical
Maximum Input Power	50W
Impedance	50 Ω

Features

- Ultra High Performance
- LoRa/Sigfox/ ISM Band coverage
- ROHS Compliant
- Robust Housing IP67 Rated
- Customizable

Mechanical Specifications

Parameter	Specification
Antenna Dimensions	Φ 48 x 82 mm
Weight	160 g
Operating Temperature	-40 °C to +70 °C
Antenna Radome Material	ABS
Connector	SMA Male
Cable Type	RG58U
Cable Length	3M
Mount Type	Screw
Antenna Color	Black
ROHS Compliant	Yes

Applications

- IOT
- Remote Monitoring
- Telematics
- Utilities
- Transportation

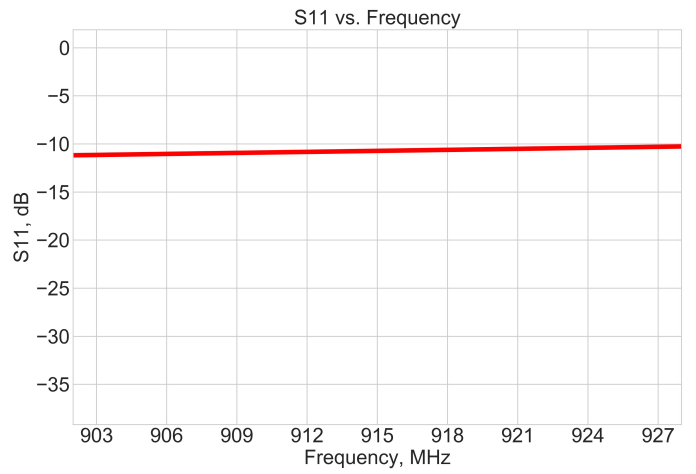
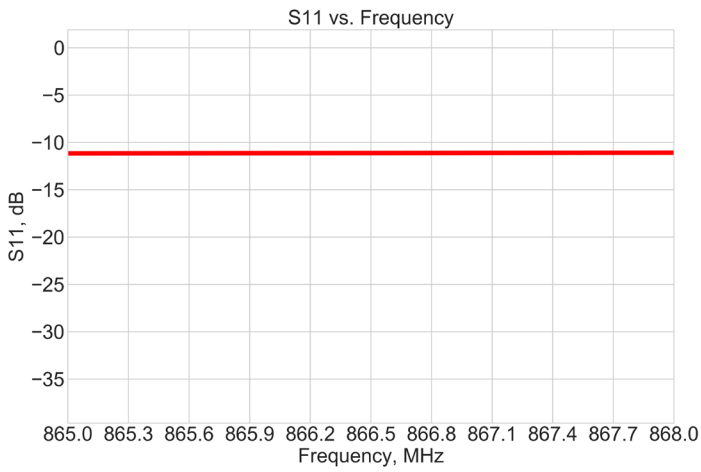

DRAWING REVISION HISTORY			
REV	DESCRIPTION	DATE	BY
A	INITIAL RELEASE	2020-12-27	QZ

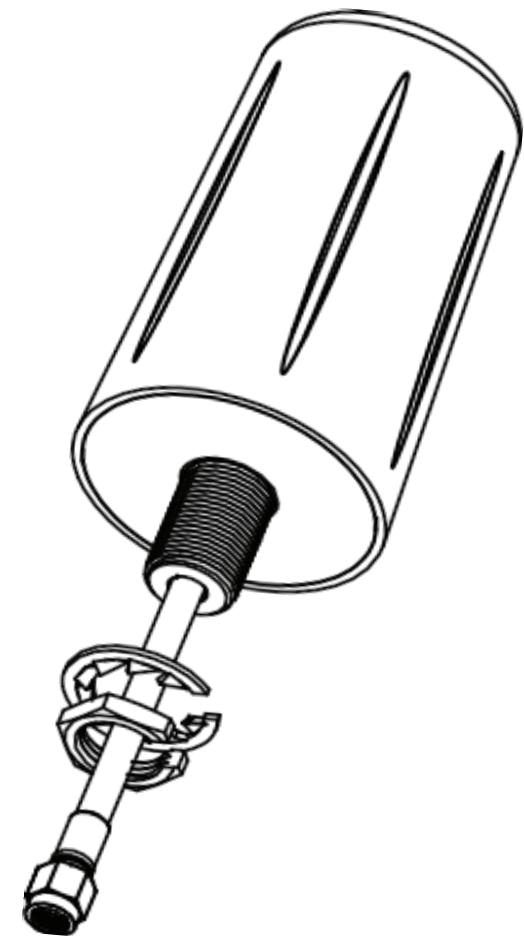
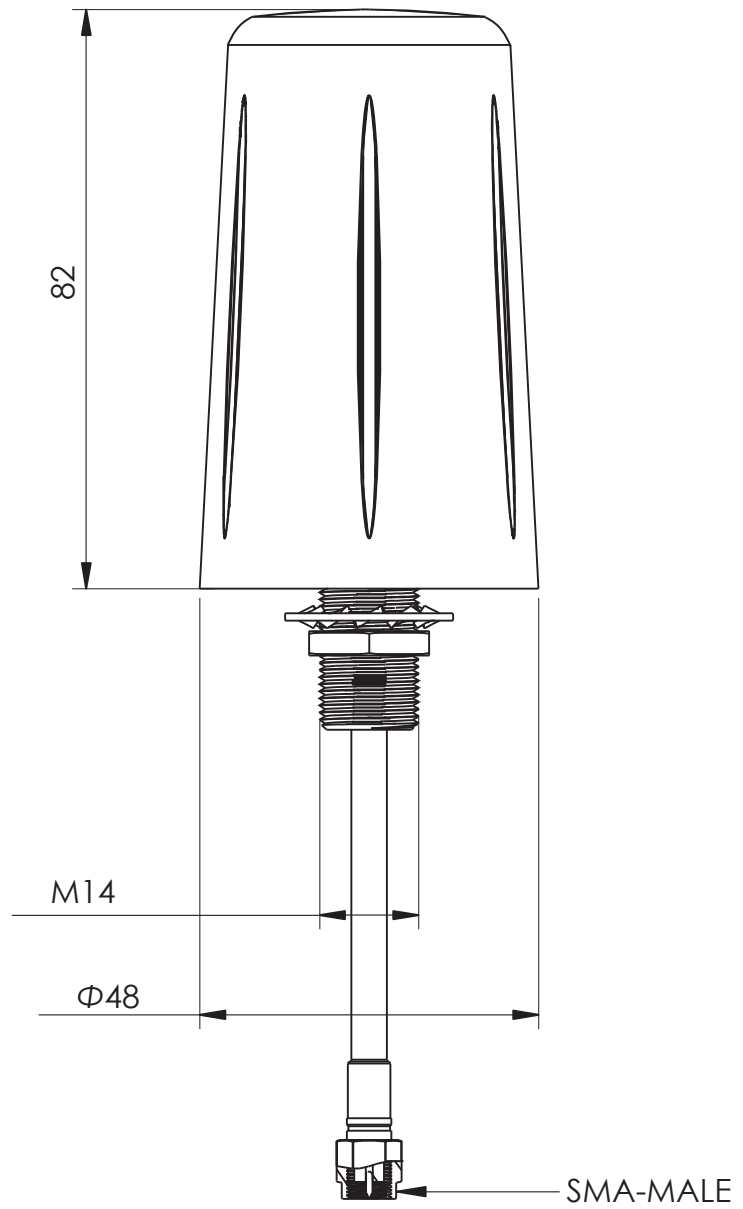
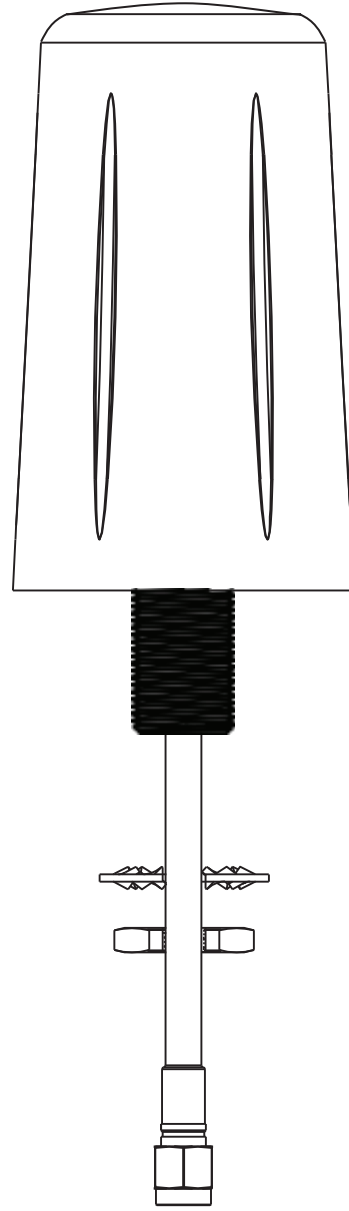

NOTES:

1. FREQUENCY: 868MHz-915MHz
2. GAIN: 3dBi
3. V.S.W.R: ≤2.5
4. CONNECTOR: SMA-MALE
5. IMPEDANCE: 50 Ω
6. TEMPERATURE: -40 °C TO +70 °C
7. INPUT POWER: 50W
8. WEIGHT: 160g

UNLESS OTHERWISE SPECIFIED:	NAME	DATE
DIMENSIONS ARE IN MM	DRAWN	QZ 2020-12-07
TOLERANCES:	CHECKED	ZX 2020-12-11
FRACTIONAL ±	ENG APPR.	NPC 2020-12-11
ANGULAR: MACH ± 0.5° BEND ±	MFG APPR.	
INTEGER ± 2	Q.A.	
ONE PLACE DECIMAL: ± 1.0		
TWO PLACE DECIMAL: ± 0.50		
INTERPRET GEOMETRIC TOLERANCING PER:		
	CAD MAINTAINED. CHANGES SHALL BE INCORPORATED BY THE DESIGN ACTIVITY.	
DO NOT SCALE DRAWING		

MAXTENA, INC		
TITLE: 100-00153-01 MEA-868-915-SMA		
SIZE	DWG. NO.	REV
B	117-00375-01	A
CAGE CODE: 5KQH7	SCALE: NONE	SHEET 1 OF 1

ITEM 100-00153-01 REVISION HISTORY			
REV	DESCRIPTION	DATE	BY
A	INITIAL RELEASE	2020-12-07	QZ

PROPRIETARY AND CONFIDENTIAL

THE INFORMATION CONTAINED IN THIS DRAWING IS THE SOLE PROPERTY OF MAXTENA, INC. ANY REPRODUCTION IN PART OR AS A WHOLE WITHOUT THE WRITTEN PERMISSION OF MAXTENA, INC IS PROHIBITED.