



**FEATURES**

- Volt. Range: 6.2V to 200V
- Low Zener Impedance
- Available in normal polarity or reverse
- DO5 Package
- 1N4554 to 1N3350

**ABSOLUTE MAX. RATINGS**

- Storage temp. range: -65°C to +150°C
- Max case operating temp.: -65°C to +150°C
- Max junction temp.: 150°C
- Power dissipation: 50W
- Power derating (derat above 75°C): 0.5 mw/°C
- Forward voltage (@2A): 1.5V

**ELECTRICAL CHARACTERISTICS @ CASE OP. TEMP. 30°C**

Nom V <sub>ZT</sub> (V)	Type Number	SPE Type	I <sub>ZT</sub> (mA)	R <sub>ZT</sub> max	I <sub>R</sub> (uA)	V <sub>R</sub> (V)	I <sub>ZM</sub> (mA)
3.9	1N4549		3200			0.5	11900
4.3	1N4550		2900			0.5	10650
4.7	1N4551		2650			1.0	9700
5.1	1N4552		2450			1.0	8900
5.6	1N4553		2250			1.0	8100
6.2	1N4554	50Z6V2	2000	0.14	20	2.0	7300
6.8	1N3305	50Z6V8	1850	0.20	300	4.5	6600
7.5	1N3306	50Z7V5	1700			5.0	5900
8.2	1N3307	50Z8V2	1450	0.45	35	5.84	5300
9.1	1N3308	50Z9	1370	0.5	25	6.82	5200
10	1N3309	50Z10	1200	0.6	25	7.50	4700
11	1N3310	50Z11	1100	0.8	10	8.25	4300
12	1N3311	50Z12	1000	1	10	9.00	3900
13	1N3312	50Z13	960	1.1	10	9.75	3500
14	1N3313	50Z14	895	1.4	10	10.50	3300
15	1N3314	50Z15	830	1.6	10	11.25	3000
16	1N3315	50Z16	780	2	10	12.00	2800
18	1N3317	50Z18	700	2.4	10	13.50	2600
20	1N3319	50Z20	630	2.5	10	15.00	2400
22	1N3320	50Z22	570	2.6	10	16.50	2000
24	1N3321	50Z24	530	2.8	10	18.00	1900
27	1N3323	50Z27	460	3	10	20.25	1600
30	1N3324	50Z30	420	3.2	10	22.50	1400
33	1N3325	50Z33	380	3.5	10	24.75	1300
36	1N3326	50Z36	350	4	10	27.00	1200
39	1N3327	50Z39	320	4.5	10	27.00	1100
43	1N3328	50Z43	290	5	10	29.25	1000
47	1N3330	50Z47	270	5.2	10	35.25	930
51	1N3332	50Z51	245	6	10	38.25	830
56	1N3334	50Z56	220	7	10	42.00	750
62	1N3335	50Z62	200	8	10	46.50	690
68	1N3336	50Z68	180	9	10	51.00	630
75	1N3337	50Z75	170	11	10	56.25	570
82	1N3338	50Z82	150	15	10	61.50	520
91	1N3339	50Z91	140	20	10	68.25	450

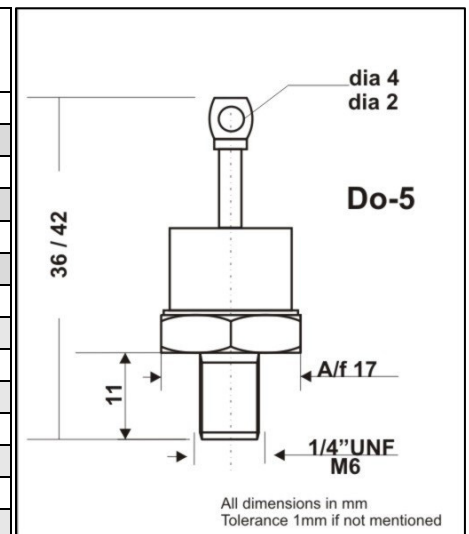

**Note:**

Normal polarity indicated anode to case.

When using Jedec standards suffix R denotes reverse polarity (cathode to case). Suffix A and B denote tolerance of 10% and 5%. No suffix indicated tolerance of 20%.





**ELECTRICAL CHARAC. (CONT.)**

100	1N3340	50Z100	120	30	10	75.00	430
110	1N3342	50Z110	110	40	10	82.50	390
120	1N3343	50Z120	100	50	10	90.00	350
130	1N3344	50Z130	95	75	10	97.50	330
140	1N3345	50Z140	90	80	10	105.0	300
150	1N3346	50Z150	85	85	10	112.5	280
160	1N3347	50Z160	80	80	10	120.0	260
180	1N3349	50Z180	68	98	10	135.0	240
200	1N3350	50Z200	65	100	10	150.0	220

$V_{ZT}$  : Continuous reverse Voltage  
 $I_{ZT}$  : Regulating voltage test current  
 $I_R$  : Reverse current at specified  $V_R$   
 $R_{ZT}$  : Differential resistance at  $I_{ZT}$   
 $I_{ZM}$  : Max DC Zener current

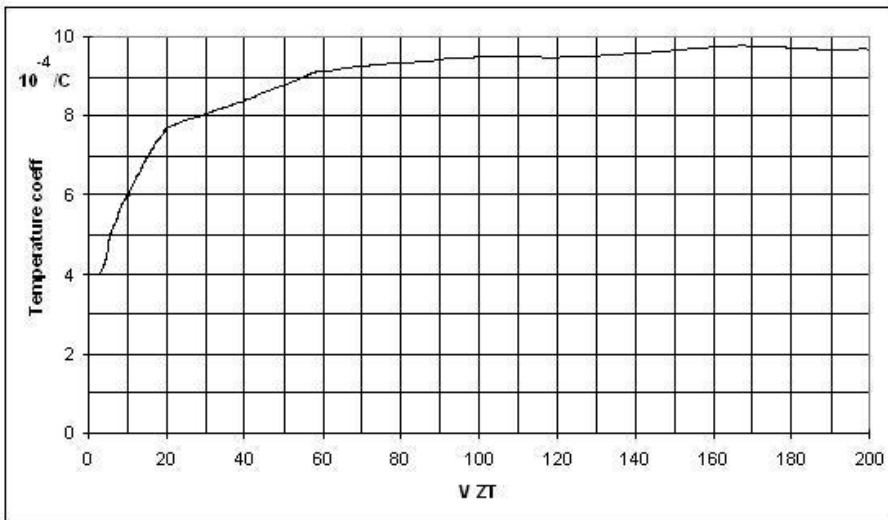

Temperature coefficient VS Zener voltage

