

"0R" Series

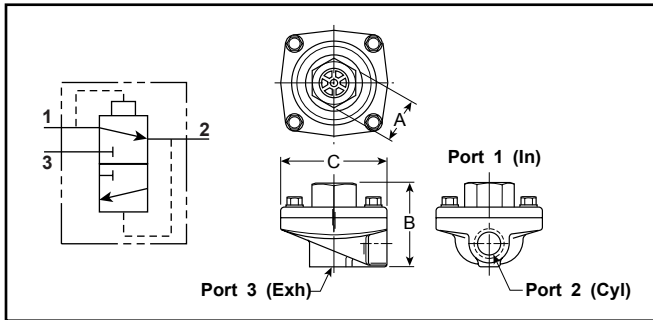
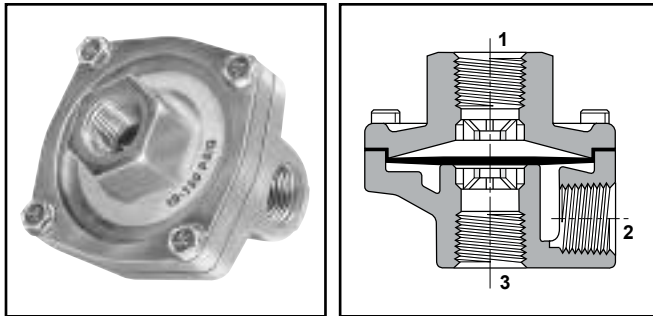

Valve Specification

Operating Pressure (Air)

Maximum:

150 PSIG
 200 PSIG for Model No. 0R37TB (PTFE diaphragm)

Minimum:

3 PSIG
 50 PSIG for Model No. 0R37TB (PTFE diaphragm)

Operating Temperature:

Urethane: 0°F to 180°F* (-18°C to 80°C)
 Nitrile: 0°F to 180°F* (-18°C to 80°C)
 Fluorocarbon: 0°F to 400°F* (-18°C to 205°C)
 PTFE: 0°F to 500°F* (-18°C to 260°C)

* Ambient temperatures below freezing require moisture-free air.
 Ambient temperatures below freezing and above 180° require lubricants especially selected for suitability at these temperatures.
 Pneumatic valves should be used with filtered and lubricated air.

**Buy Online at
 Store.LivHaven.com**

Component Materials

Body Material Die cast aluminum
Static Seals Nitrile standard with urethane
 (Others see below)
Diaphragm Standard – Urethane
 Optional – Fluorocarbon, PTFE, or Nitrile
 (Depending on size)

General Information

Quick exhaust valves provide rapid exhaust of control air when placed between control valve and actuator. They can also be used as shuttle valves. Diaphragm materials are available in urethane, Nitrile, Fluorocarbon, and PTFE to meet a wide variety of operating conditions.

Mounting Bracket Kit – No. 03640 8100

(Including body screws)
 For "0R12" and "0R25" sizes
 with 7/8" "A" Dimension.

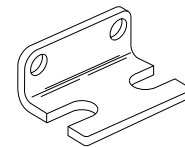

Model Selection, Performance Data and Dimensions

Port			Flow (SCFM) [†]	Model Number		A	B	C	Service Kit No.
1	2	3		NPTF	BSPP "G"				
STANDARD URETHANE DIAPHRAGMS (Nitrile static seals)									
1/8"	1/8"	1/8"	70	0R12B	0RB12B	7/8" Sq.	1.75	1.88	03640 8000
	1/8"	1/4"	70	0R12NB	0RB12NB	7/8" Sq.	1.75	1.88	03640 8000
1/4"	1/4"	1/4"	90	0R25B	0RB25B	7/8" Sq.	1.75	1.88	03640 8000
	1/4"	3/8"	150	0R25NB	0RB25NB	1" Hex	2.06	2.44	03340 0105
	3/8"	3/8"	240	0R25PB	—	1" Hex	2.06	2.44	03340 0105
3/8"	3/8"	3/8"	240	0R37B	0RB37B	1" Hex	2.06	2.44	03340 0105
1/2"	1/2"	1/2"	450	0R50B	0RB50B	1-1/2" Hex	2.88	3.38	03475 0109
3/4"	3/4"	3/4"	550	0R75B	0RB75B	1-1/2" Hex	2.88	3.38	03475 0109
NITRILE DIAPHRAGMS (Nitrile static seals)									
1/4"	1/4"	3/8"	90	0R25NFB	0RB25NFB	7/8" Sq.	1.75	1.88	03340 8000
3/8"	3/8"	3/8"	240	0R37FB	0RB37FB	1" Hex	2.06	2.44	03340 8000
3/4"	3/4"	3/4"	550	0R75FB	0RB75FB	1-1/2" Hex	2.88	3.38	03475 9000
FLUOROCARBON DIAPHRAGMS for extended temperature operation (Fluorocarbon static seals)									
1/8"	1/8"	1/8"	70	0R12VB	0RB12VB	7/8" Sq.	1.75	1.88	03650 8000
	1/8"	1/4"	70	0R12NVB	0RB12NVB	7/8" Sq.	1.75	1.88	03650 8000
1/4"	1/4"	1/4"	90	0R25VB	0RB25VB	7/8" Sq.	1.75	1.88	03650 8000
3/8"	3/8"	3/8"	240	0R37VB	0RB37VB	1" Hex	2.06	2.44	03340 0319
1/2"	1/2"	1/2"	450	0R50VB	0RB50VB	1-1/2" Hex	2.88	3.38	03475 0120
3/4"	3/4"	3/4"	550	0R75VB	0RB75VB	1-1/2" Hex	2.88	3.38	03475 0120
PTFE DIAPHRAGMS for higher pressure and temperature (Fibre static seals)									
3/8"	3/8"	3/8"	240	0R37TB	0RB37TB	1" Hex	2.06	2.44	03340 0504

† At 100 PSIG inlet pressure with full pressure drop.

BOLD ITEMS ARE MOST POPULAR.



Typical “Quick Exhaust Valve” Applications

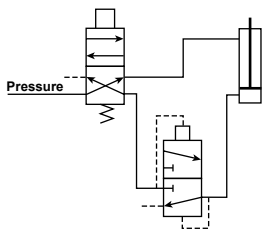

Rapid Retraction – Double Acting Cylinder

In this circuit, air is exhausted through a Quick Exhaust Valve that is **close coupled** to the cap end of the cylinder. Because the Quick Exhaust Valve has a greater exhaust capacity than the four-way Control Valve, increased cylinder speed can be accomplished with a smaller and less expensive control valve.

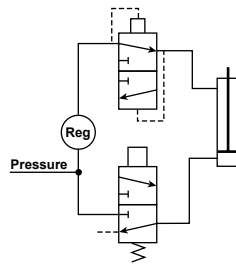

Dual Pressure Actuation of Double Acting Cylinder

This circuit utilizes a Quick Exhaust Valve and a three-way Control Valve to permit rapid extension of the cylinder at a high pressure, thus saving air and increasing cylinder life.

NOTE: Line pressure must be 3 or 4 times greater than rod end pressure. Effective working pressure is the differential between the cap and rod end.

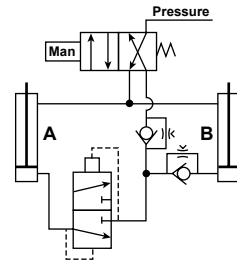

Bi-Directional Control of Two Double Acting Cylinders

This circuit provides maximum control with a minimum of valving. A large four-way Control Valve is not needed to permit the rapid retraction of Cylinder A, as the Quick Exhaust Valve performs this function. The extension of Cylinders A and B and retraction of Cylinder B are controlled by Speed Control Valves.

Typical “Shuttle Valve” Applications

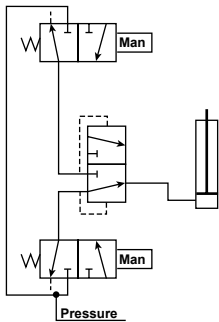

“OR” Circuit

The most common application of the Shuttle Valve is the “OR” Circuit. Here a cylinder or other work device can be actuated by either control valve. The valves can be manually or electrically actuated and located in any position.

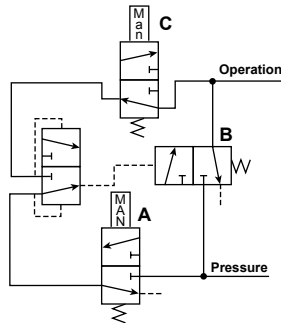

Memory Circuit

This circuit enables continuous operation once initiated. Pressure is delivered to the circuit when Valve A is actuated. This allows pressure to pass through the shuttle valve actuating Valve B. Pressure then flows through Valve B and also the other side of the shuttle valve which holds Valve B open for continuous operation. To unlock the circuit, Valve C must be opened to exhaust the circuit and allow Valve B to return to its normally closed position.

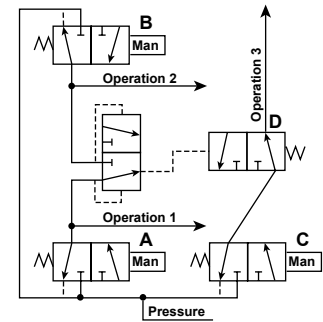

Interlock

This circuit prevents the occurrence of a specific operation while one or another operation takes place. When either Valve A or B is actuated to perform operation 1 or 2, Valve D is shifted to the closed position and prevents operation 3 from occurring.

