

Surface Mount Microprocessor Crystal



12.5 x 4.85 x 5.1mm

ABS M3B

RoHS / RoHS II Compliant

Pb in glass exemption 7 (c)-I per RoHS II 2011/65/EU Annex

Moisture Sensitivity Level – MSL – N/A

(The ABS M3A Series is a Hermetically Sealed device and not moisture sensitive)

FEATURES:

- Excellent all-purpose surface-mount crystal.
- Four pad land pattern compatible with common plastic molded designs.

APPLICATIONS:

- Home electronics
- Computers, modems, and communications
- Clock applications
- Microprocessors

STANDARD SPECIFICATIONS:

Parameters	Minimum	Typical	Maximum	Units	Notes
Frequency Range	3.579545		60	MHz	
Operation Mode	3.579545MHz ~ 30.00MHz: Fundamental, AT				Standard
	30.01MHz ~ 39.99MHz: Fundamental, BT				Standard
	40.00MHz ~ 60.00MHz: 3 rd OT				Standard
	40.00MHz ~ 48.00MHz: Fundamental, BT				Option "FB"
Operating Temperature	-10		+60	°C	See options
Storage Temperature	-40		+85	°C	
Frequency Tolerance	-50		+50	ppm	See options
Frequency Stability over the Operating Temperature (ref. to +25°C ± 3 °C)	-100		+100	ppm	See options
Equivalent series resistance (R1)			150	Ω	3.579545MHz ~ 3.999MHz
			120		4.000 MHz ~ 4.999MHz
			90		5.000MHz ~ 6.999MHz
			50		7.000MHz ~ 14.999MHz
			40		15.000MHz ~ 48.000MHz (Fund.)
			80		40.000MHz ~ 60.000MHz (3 rd OT)
Shunt capacitance (C0)			7.0	pF	
Load capacitance (CL)		18		pF	See options
Drive Level		100	1000	μW	
Aging (per year) @25°C ± 3 °C	-5		+5	ppm	
Insulation Resistance	500			MΩ	@100Vdc±15V

Surface Mount Microprocessor Crystal



12.5 x 4.85 x 5.1mm

ABSM3B

RoHS / RoHS II Compliant

Pb in glass exemption 7 (c)-I per RoHS II 2011/65/EU Annex

OPTIONS & PART IDENTIFICATION: (Left blank if standard)

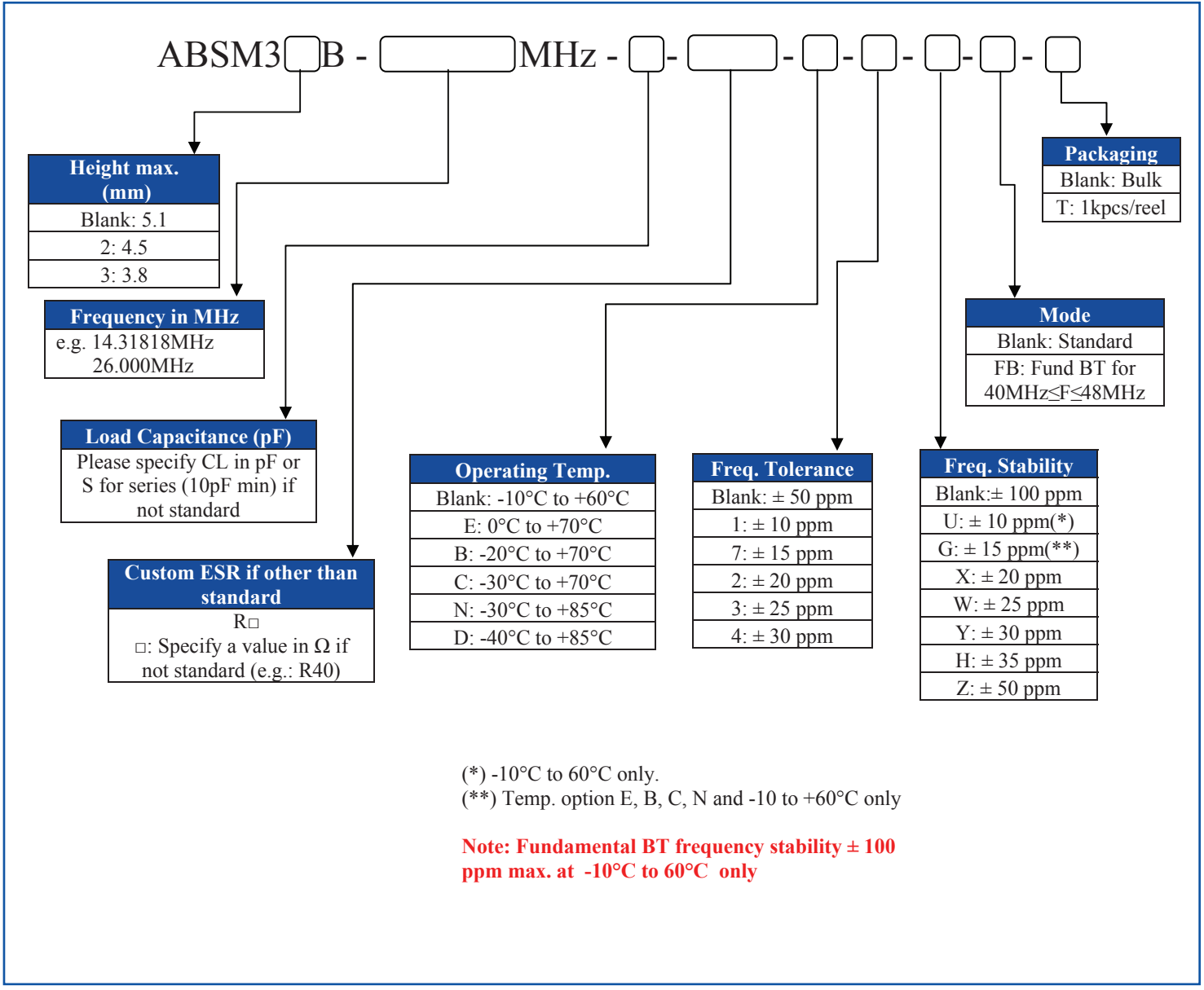

Surface Mount Microprocessor Crystal



12.5 x 4.85 x 5.1mm

ABSM3B



RoHS / RoHS II Compliant

Pb in glass exemption 7 (c)-I per RoHS II 2011/65/EU Annex

OUTLINE DIMENSION:

P/N	Height max. (mm)
ABSM3B	5.1
ABSM32B	4.5
ABSM33B	3.8

Dimensions: mm

REFLOW PROFILE:

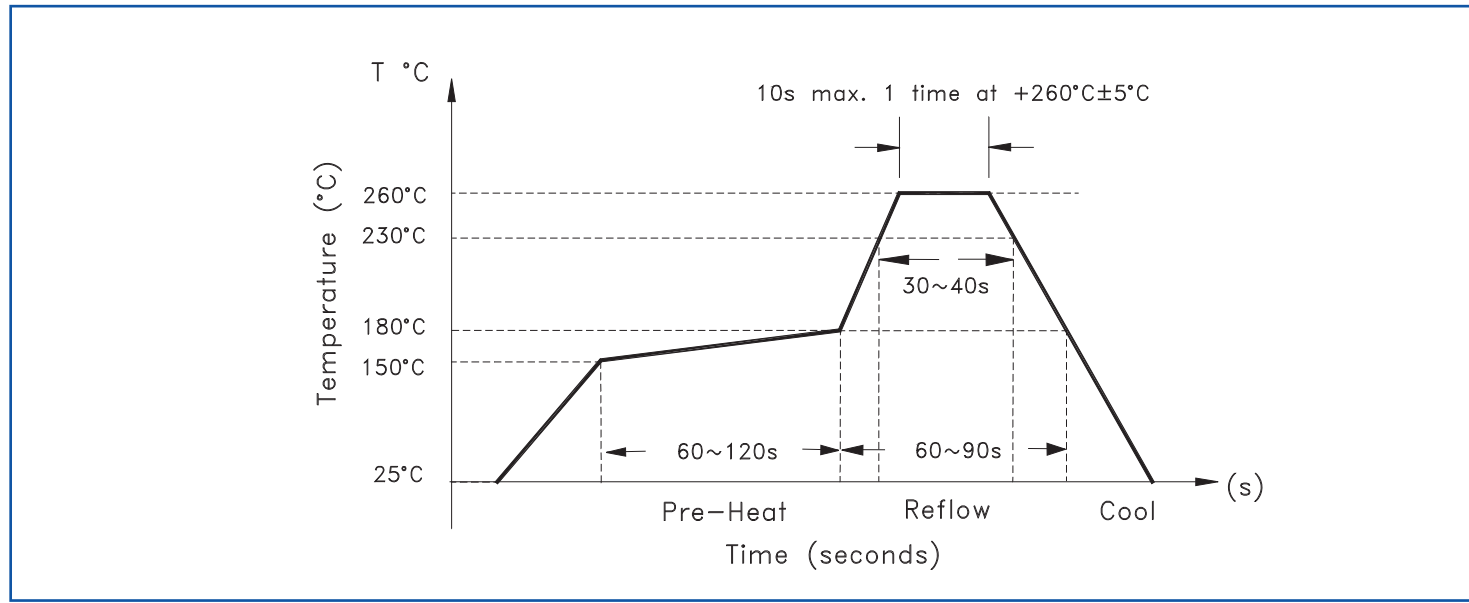

Surface Mount Microprocessor Crystal



12.5 x 4.85 x 5.1mm

ABSM3B

RoHS / RoHS II Compliant

Pb in glass exemption 7 (c)-I per RoHS II 2011/65/EU Annex

TAPE & REEL:

T=Tape and Reel (1000pcs/reel)

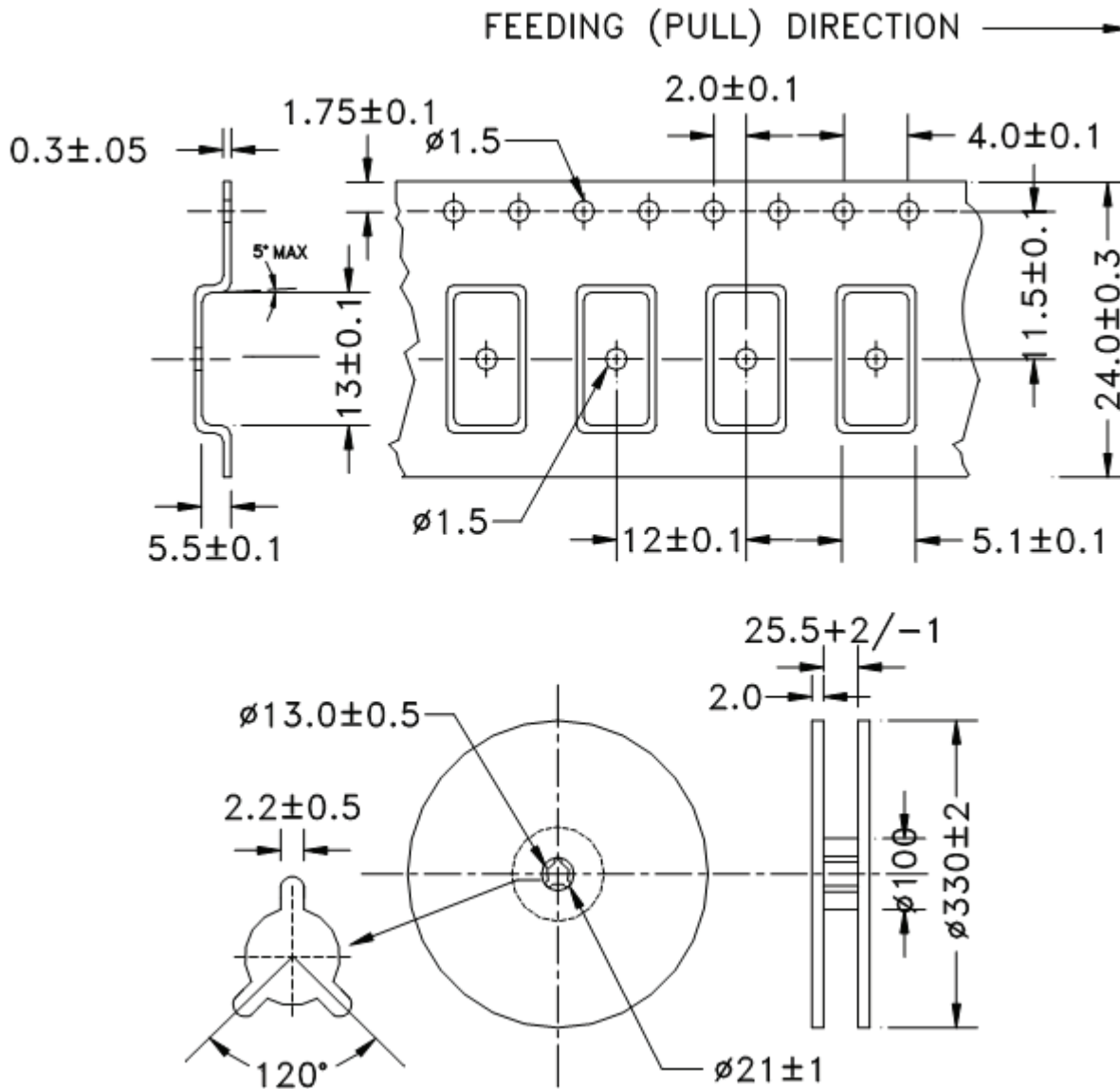

Dimensions: mm

ATTENTION: Abracon Corporation's products are COTS – Commercial-Off-The-Shelf products; suitable for Commercial, Industrial and, where designated, Automotive Applications. Abracon's products are not specifically designed for Military, Aviation, Aerospace, Life-dependant Medical applications or any application requiring high reliability where component failure could result in loss of life and/or property. For applications requiring high reliability and/or presenting an extreme operating environment, written consent and authorization from Abracon Corporation is required. Please contact Abracon Corporation for more information.

ABRACON IS
ISO 9001:2008
CERTIFIED



2 Faraday, Suite# B | Irvine | CA 92618 Revised: 04.30.15

Ph. 949.546.8000 | Fax. 949.546.8001

Visit www.abracon.com for Terms and Conditions of Sale