



Product availability: Stock - Normally stocked in distribution facility



Main

Range of product	Advantys Telefast ABE7
Product or component type	Electromechanical output relay sub-base
[Us] rated supply voltage	24 V DC (PLC end)
Number of channels	16
Number of terminal per channel	1

Complementary

Terminal block type	Removable
Polarity distribution	Polarity distribution contact common per group of 8 channels
Fixing mode	By clips on 35 mm symmetrical DIN rail By screws on solid plate with fixing kit
Width	4.92 in (125 mm)
Current per output common	≤ 12 A
Current per channel	2 A (preactuator end)
Minimum switching current	1 mA at ≥ 5 V
Drop-out voltage	2.4 V at 68 °F (20 °C) (PLC end)
Switching frequency	≤ 0.5 Hz ≤ 10 Hz
Threshold tripping voltage	At 40 °C
Drop-out current	0.5 mA at 68 °F (20 °C)
Power dissipation per channel in W	≤ 0.22 W (PLC end)
Contacts type and composition	1 NO (preactuator end)
Maximum switching voltage	250 V AC 50/60 Hz conforming to IEC 60947-5-1 30 V DC conforming to IEC 60947-5-1
Number of channel per common	8
Electrical durability	500000 cycles, maximum switching current: 200 mA at 24 V DC-13 10 ms (preactuator end) 500000 cycles, maximum switching current: 400 mA at 230 V AC-15 (preactuator end) 500000 cycles, maximum switching current: 600 mA at 230 V AC-12 (preactuator end) 500000 cycles, maximum switching current: 600 mA at 24 V DC-12 (preactuator end)
Electrical reliability	1e-008
Operating time	≤ 10 ms between coil energisation and NO closing ≤ 6 ms between coil de-energisation and NO opening
Contact bounce time	≤ 5 ms 1 NO
Operating rate in Hz	10 Hz no load 0.5 Hz at Ie
Mechanical durability	20000000 cycles
[Uimp] rated impulse withstand voltage	2.5 kV conforming to IEC 60947-1
[Ui] rated insulation voltage	2000 V
Installation category	II conforming to IEC 60664-1

The information provided in this documentation contains general descriptions and/or technical characteristics of the performance of the products contained herein. This documentation is not intended as a substitute for and is not to be used for determining suitability or reliability of these products for specific user applications. It is the duty of any such user or integrator to perform the appropriate and complete risk analysis, evaluation and testing of the products with respect to the relevant specific application or use thereof. Neither Schneider Electric Industries SAS nor any of its affiliates or subsidiaries shall be responsible or liable for misuse of the information contained herein.

Tightening torque	5.31 lbf.in (0.6 N.m) (with flat Ø 3.5 mm)
Product weight	0.89 lb(US) (0.405 kg)

Environment

Max immunity to microbreaks	<= 5 ms
Dielectric strength	2000 V conforming to IEC 60947-1
Product certifications	BV CSA DNV GL LROS (Lloyds register of shipping) UL
IP degree of protection	IP2x conforming to IEC 60529
Protective treatment	TC
Resistance to incandescent wire	1382 °F (750 °C), extinction time: < 30 s conforming to IEC 60695-2-11
Shock resistance	15 gn 11 ms conforming to IEC 60068-2-27
Resistance to radiated fields	9.14 V/yd (10 V/m) (26000000...1000000000 Hz) conforming to IEC 61000-4-3 level 3
Resistance to fast transients	2 kV conforming to IEC 61000-4-4 level 3
Ambient air temperature for operation	23...140 °F (-5...60 °C) conforming to IEC 61131-2
Ambient air temperature for storage	-40...176 °F (-40...80 °C) conforming to IEC 61131-2
Pollution degree	2 conforming to IEC 60664-1

Ordering and shipping details

Category	22375 - INTERFACE MODULE(ABA,R,S)
Discount Schedule	CP2
GTIN	00785901545279
Nbr. of units in pkg.	1
Package weight(Lbs)	0.7700000000000002
Returnability	Y
Country of origin	LV

Offer Sustainability

Sustainable offer status	Green Premium product
RoHS (date code: YYWW)	Compliant - since 0841 - Schneider Electric declaration of conformity Schneider Electric declaration of conformity
REACH	Reference not containing SVHC above the threshold
Product environmental profile	Available
Product end of life instructions	Available
California proposition 65	WARNING: This product can expose you to chemicals including:
----- Substance 1	Lead and lead compounds, which is known to the State of California to cause cancer and birth defects or other reproductive harm.
----- More information	For more information go to www.p65warnings.ca.gov

Contractual warranty

Warranty period	18 months
-----------------	-----------

Dimensions

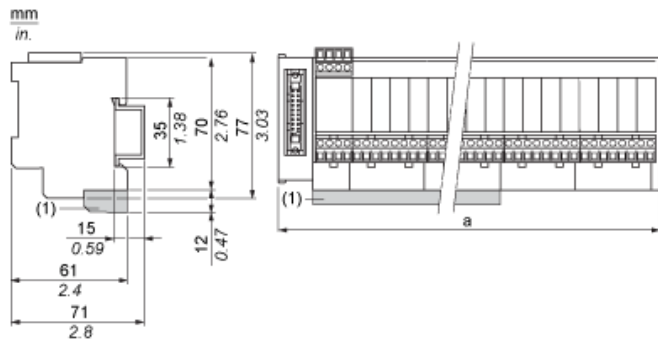

(1) ABE7BV20 / ABE7BV20E

ABE7	a in mm	a in in.
R16S111 / R16S111E	125	4.92
R16S21 / R16S21•E	206	8.11

Mounting



HE10 16 Channels

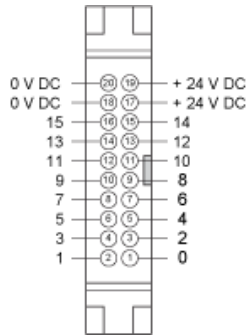

Wiring Diagram

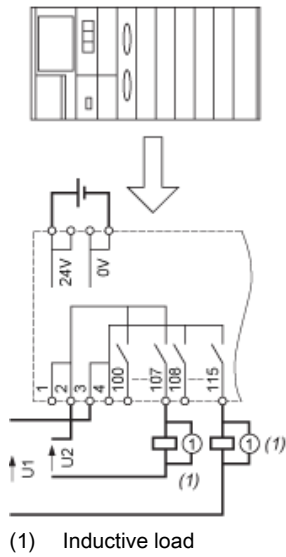

Curves for Determining Cable Type and Length According to the Current

16-channel Sub-base

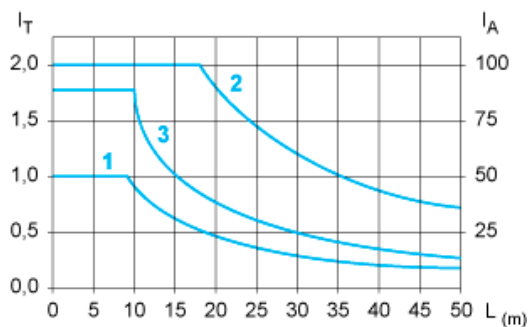

- L Cable length
- I_T Total current per sub base (A)
- I_A Average current per channel (mA)
- (1) TSXCDP••2 and ABFH20H••0 cables with c.s.a. 0.08 mm^2 (AWG 28).
- (2) TSXCDP••3 cables with c.s.a. 0.34 mm^2 (AWG 22).
- (3) Cables with c.s.a. 0.13 mm^2 (AWG 26).

The curves are given for a voltage drop of 1 V in the cable. For n volts tolerance, multiply the length determined from the graph by n.

Temperature Derating Curves

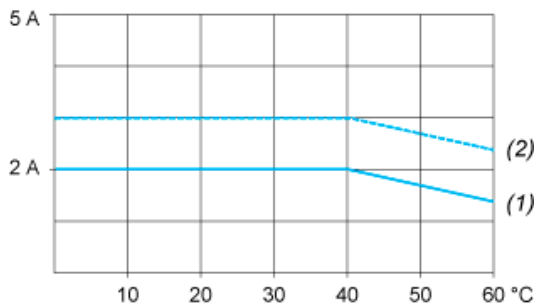

- (1) 100 % of channels used
- (2) 50 % of channels used

Electrical Durability (in Millions of Operating Cycles) Conforming to IEC 60947-5-1

DC Loads

DC12 curves

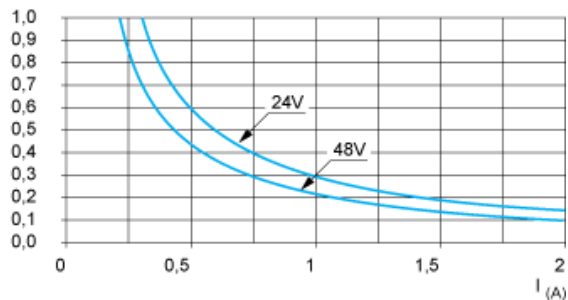

DC12control of resistive loads and of solid state loads isolated by optocoupler, $I/R \leq 1 \text{ ms}$.

DC13 curves

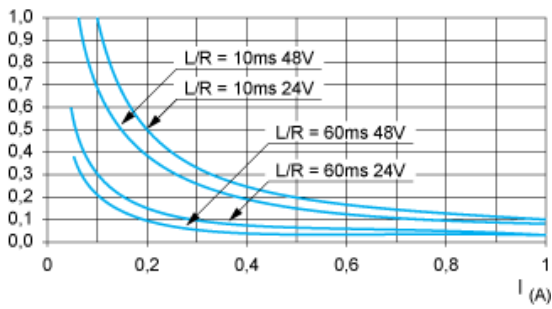

DC13switching electromagnets, $L/R \leq 2 \times (U_e \times I_e)$ in ms, U_e : rated operational voltage, I_e : rated operational current (with a protective diode on the load, DC12 curves must be used with a coefficient of 0.9 applied to the number in millions of operating cycles)

AC Loads

AC12 curves

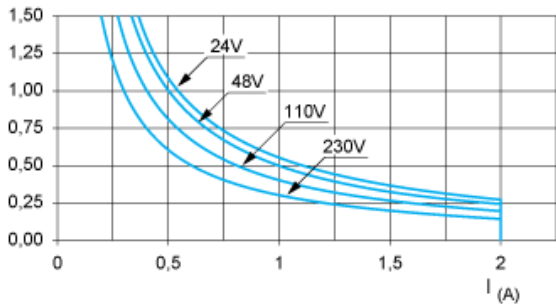

AC12control of resistive loads and of solid state loads isolated by optocoupler, $\cos \phi \geq 0.9$.

AC14 curves

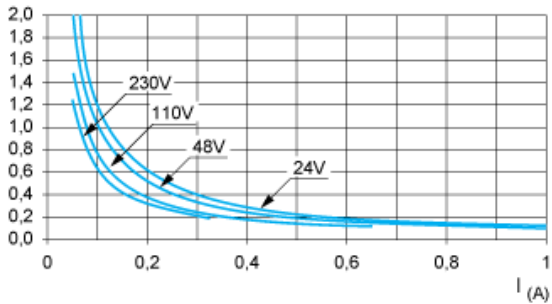

AC14control of small electromagnetic loads ≤ 72 VA, make: $\cos \phi = 0.3$, break: $\cos \phi = 0.3$.

AC15 curves

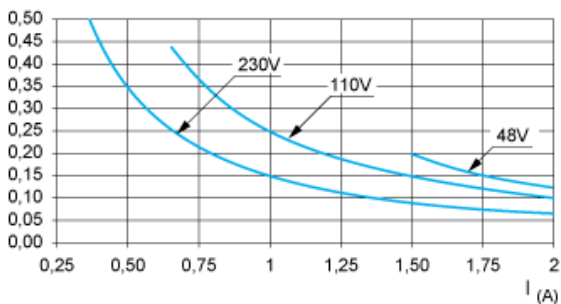

AC15control of electromagnetic loads > 72 VA, make: $\cos \phi = 0.7$, break: $\cos \phi = 0.4$.