

Motor/Actuator Drivers DC Brush Motor Series

Automotive 1ch H Bridge Driver (50V Max)

BD6941FM

General Description

BD6941FM is a reversible motor driver with an output current of 1.25A (1Motor). It can control a DC motor in four modes: Forward, Reverse, Standby, and Brake, using two control logic inputs.

Features

- 1ch DMOS H Bridge Output
- Four Output States (Forward, Reverse, Standby, and Brake) through two Control Logic
- Low Standby Current
- Built-in Output Counter-Electromotive Force Absorption Diode
- Over-Current Protection with Timer (OVP)
- Over Voltage Detection (Switch OFF)
- TSD Detects Junction Temperature and Circuitry Switches OFF the Outputs at High Temperature.
- Built-in Over-Current Protection Monitor Pin (PO)

Key Specifications

- Input Supply Voltage Range: 8.0V to 16V
- Output ON Resistor(Total): 0.84Ω(Typ)
- Output Current: 1.25A(Max)
- Operating Temperature Range: -40°C to +105°C

Package

HSOP-M36

W (Typ) x D (Typ) x H (Max)
18.50mm x 9.90mm x 2.40mm

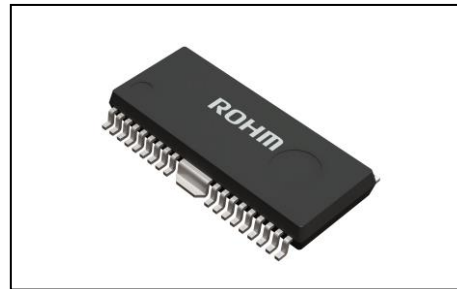

Applications

Onboard Devices (Vehicle Equipment, etc.)

Typical Application Circuit and Block Diagram

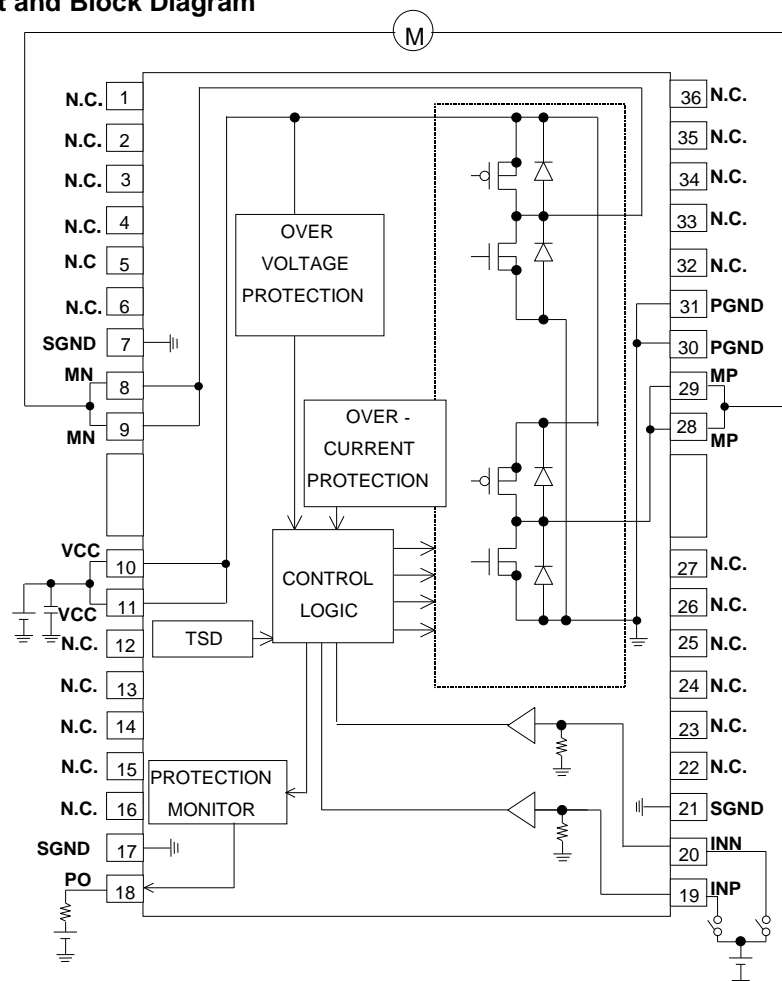

○Product structure : Silicon monolithic integrated circuit ○This product has no designed protection against radioactive rays

Pin Configuration

TOP VIEW

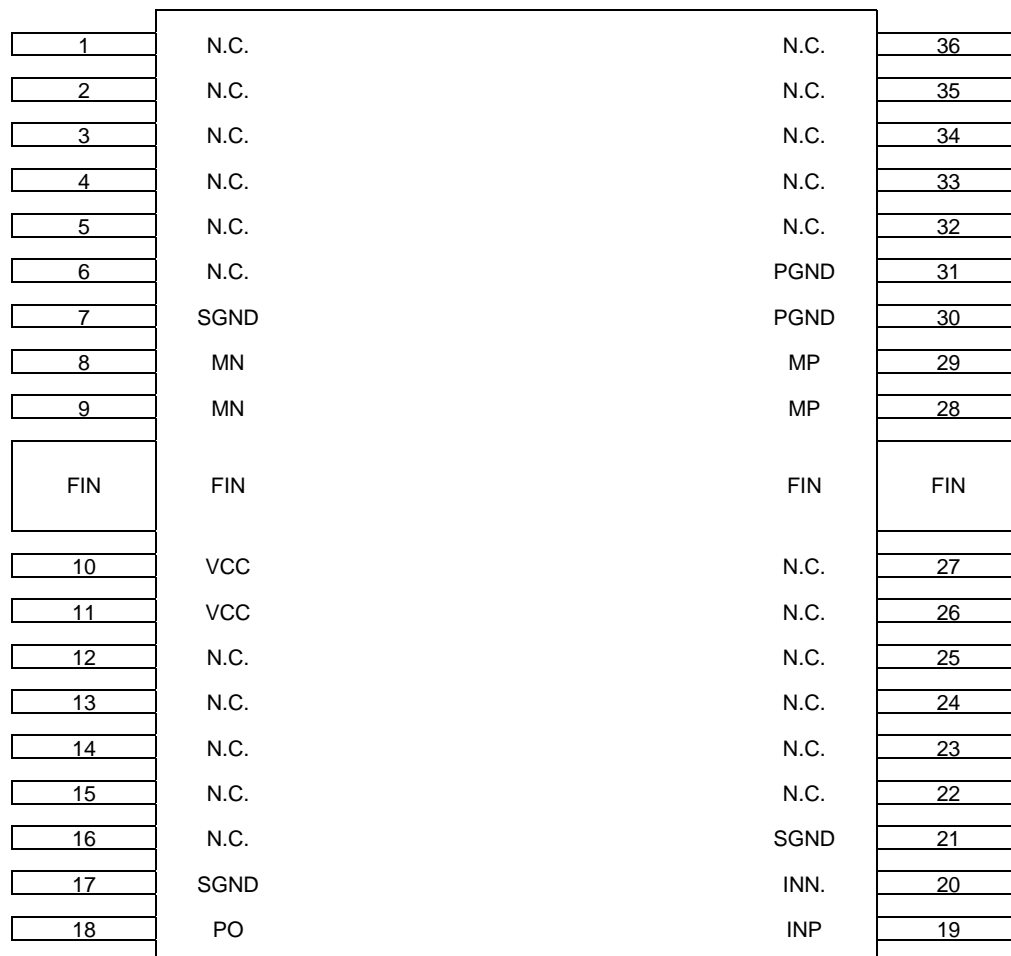

Pin Descriptions

Pin No.	Terminal Name	Function
1-6	N.C.	N.C.
7	SGND	Signal GND pin
8	MN	Motor output pin
9	MN	Motor output pin
FIN	FIN	FIN
10	VCC	Power supply pin
11	VCC	Power supply pin
12-16	N.C.	N.C.
17	SGND	Signal GND PIN
18	PO	Protection monitor
19	INP	Logic input pin
20	INN	Logic input pin
21	SGND	Signal GND pin
22-27	N.C.	N.C.
FIN	FIN	FIN
28	MP	Motor output pin
29	MP	Motor output pin
30	PGND	Power GND Pin
31	PGND	Power GND Pin
32-36	N.C.	N.C.

Absolute Maximum Ratings (Ta=25°C)

Parameter	Symbol	Limit	Unit
Supply Voltage	V _{CC}	50	V
Input Voltage	V _{INP} , V _{INN}	-0.3 to +20	V
Output Current	I _{OUT}	1.25 (Note 1)	A
Power Dissipation	P _d	2.80 (Note 2)	W
Operating Temperature	T _{opr}	-40 to +105	°C
Storage Temperature	T _{stg}	-55 to +150	°C
Junction Temperature	T _{jmax}	150	°C

(Note 1) Not to exceed P_d and ASO.

(Note 2) Mounted on a glass epoxy PCB (70mm x 70mm x 1.6mm).

To use at temperature above Ta=25°C reduce 22.4mW/°C.

Caution: Operating the IC over the absolute maximum ratings may damage the IC. The damage can either be a short circuit between pins or an open circuit between pins and the internal circuitry. Therefore, it is important to consider circuit protection measures, such as adding a fuse, in case the IC is operated over the absolute maximum ratings.

Recommended Operating Conditions

Parameter	Symbol	Limit			Unit
		Min	Typ	Max	
Supply Voltage	V _{CC}	8	12	16	V

Electrical Characteristics (Unless otherwise specified, V_{CC}=8V to 16V, Ta=-40°C to +105°C)

Parameter	Symbol	Limit			Unit	Conditions
		Min	Typ	Max		
Circuit Current 1	I _{CC1}	-	0	10	μA	Standby mode
Circuit Current 2	I _{CC2}	-	3	8	mA	Forward or reverse mode
Circuit Current 3	I _{CC3}	-	3	8	mA	Brake mode
Input Voltage "H" Level	V _{IH}	3.0	-	-	V	
Input Voltage "L" Level	V _{IL}	-	-	1.0	V	
"H" Level Input Current	I _{IH}	-	50	100	μA	V _{IN} =5.0V, flowing in current
"L" Level Input Current	I _{IL}	-	0	10	μA	V _{IN} =0V, flowing out current
Output On Voltage 1	V _{ON1}	-	0.84	1.5	V	V _{CC} =12V, I _{OUT} =0.5A, total drop
Output On Voltage 2	V _{ON2}	-	-	1.7	V	V _{CC} =8V to 16V, I _{OUT} =0.5A, total drop
Output Leakage Current "H"	I _{LH}	-	0	10	μA	V _{OUT} =0V
Output Leakage Current "L"	I _{LL}	-	0	10	μA	V _{OUT} =V _{CC}
Upper Free-Wheeling Diode Forward Voltage	V _{FH}	0.3	1.0	1.5	V	I _F =0.6A
Lower Free-Wheeling Diode Forward Voltage	V _{FL}	0.3	1.0	1.5	V	I _F =0.6A
Protection Monitor Voltage	V _{LPO}	-	-	0.6	V	I _{PO} =3mA
Protection Monitor Leakage Current	I _{LPO}	-	0	10	μA	V _{PO} =V _{CC}
Over-Current Protection Switch On Current	I _{OCP}	1.5	-	3.5	A	
Over Voltage Lockout Switch On Voltage	V _{OVF}	25	30	35	V	

Typical Performance Curves

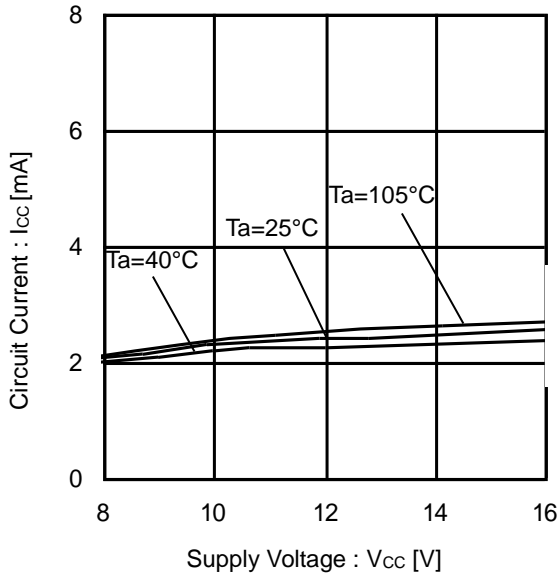

Figure 1. Circuit Current vs Supply Voltage (Forward · Reverse · Brake)

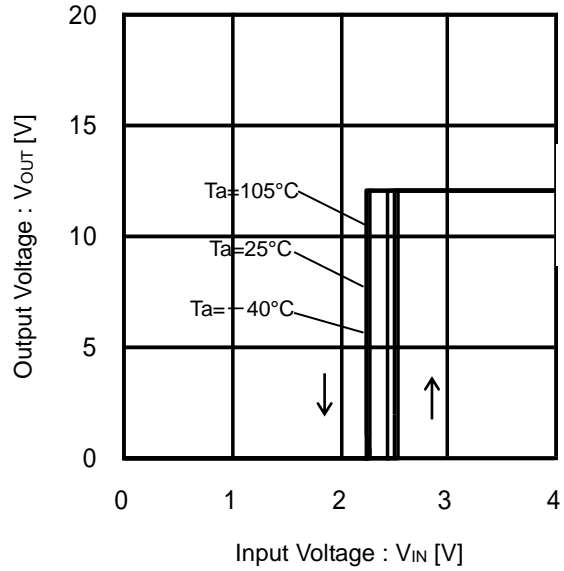

Figure 2. Output Voltage vs Input Voltage

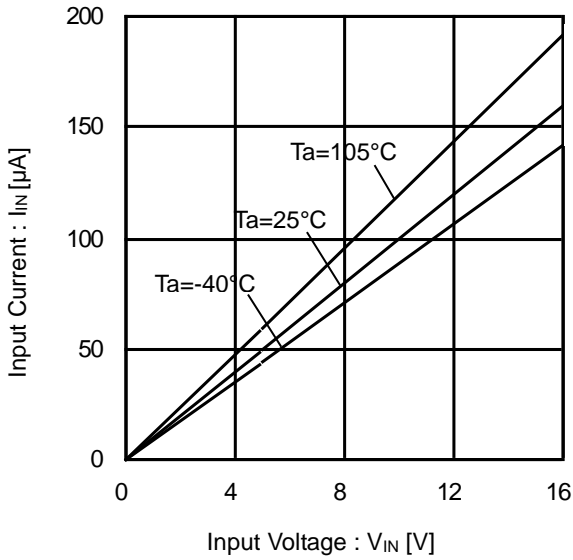

Figure 3. Input Current vs Input Voltage ("H" Level Input Current)

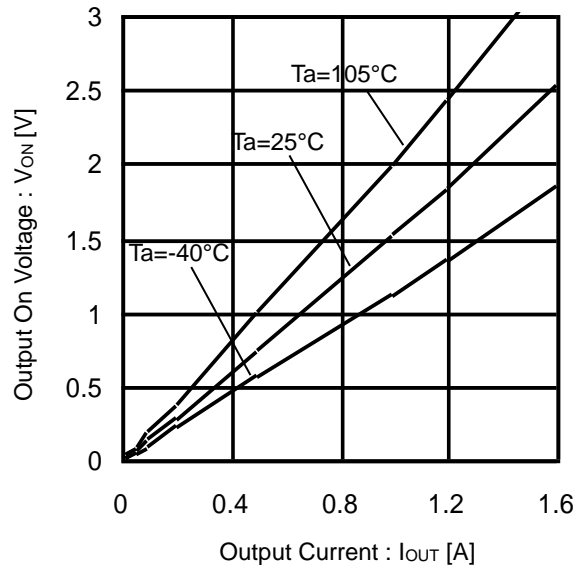

Figure 4. Output On Voltage vs Output Current (V_{cc}=12V)

Typical Performance Curves – continued

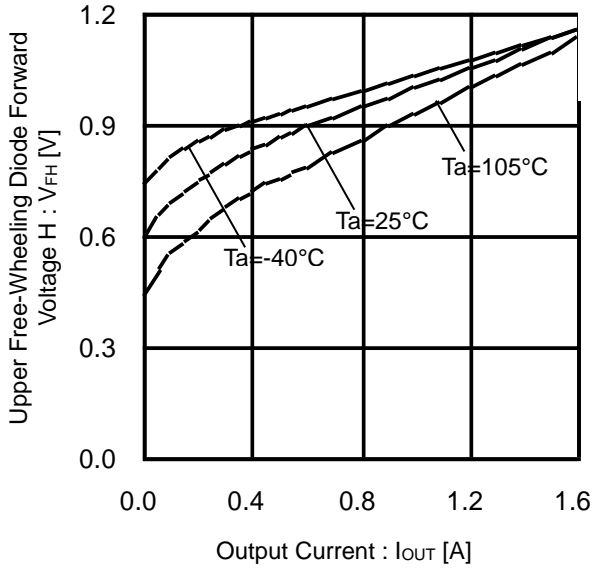

Figure 5. Upper Free-Wheeling Diode Forward Voltage H vs Output Current

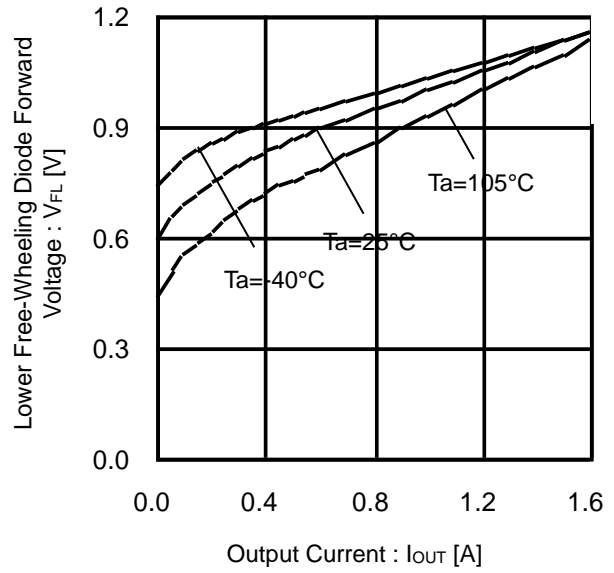

Figure 6. Upper Free-Wheeling Diode Forward Voltage L vs Output Current

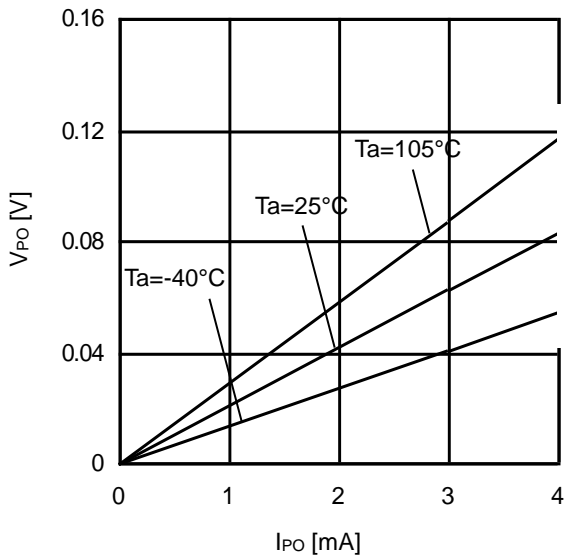

Figure 7. V_{PO} vs I_{PO} (Protection Monitor Voltage)

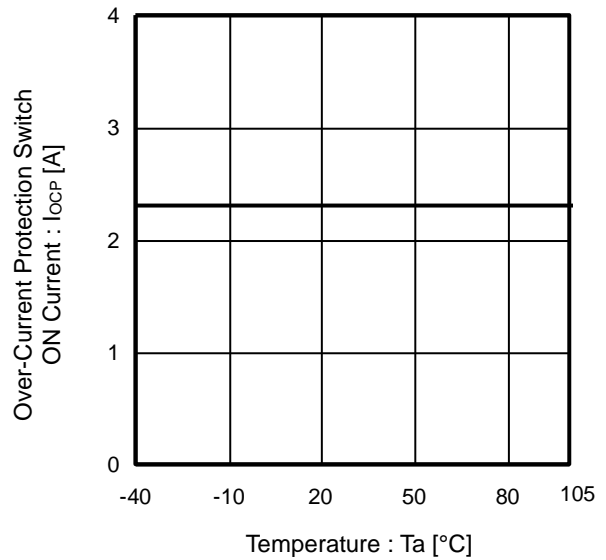

Figure 8. Over-Current Protection Switch on Current vs Temperature

Typical Performance Curves – continued

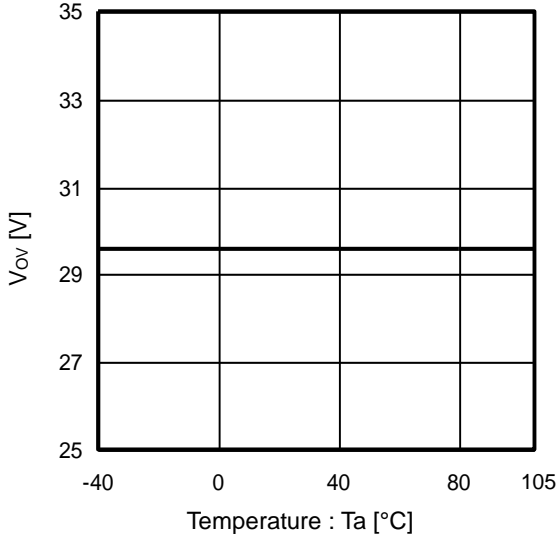

Figure 9. Over Voltage Lockout Switch On Voltage vs Temperature

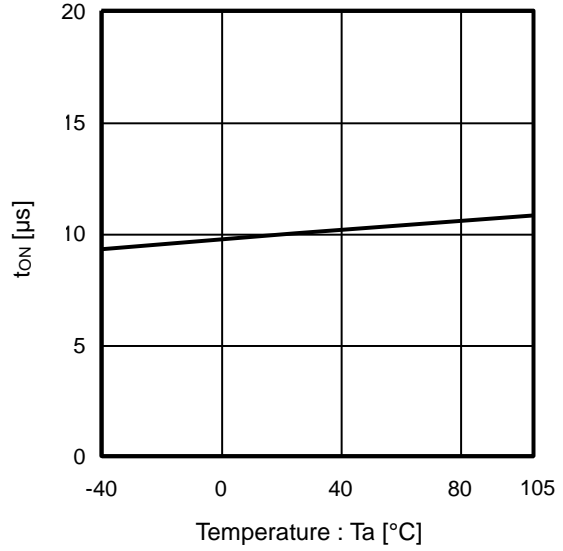

Figure 10. Over-Current Protection Monitor On Time vs Temperature

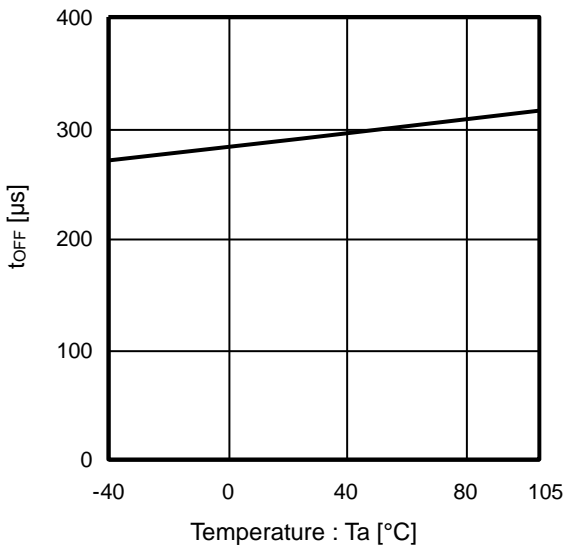

Figure 11. Over-Current Protection Monitor OFF Time vs Temperature

Application Information

1. Signal Table

(1) Input/Output Truth Table

IN		OUT		MODE
INP	INN	MP	MN	
H	H	L	L	BRAKE
H	L	H	L	FORWARD
L	H	L	H	REVERSE
L	L	OPEN	OPEN	STANDBY

(2) Output Condition

IN		OUT		PO
INP	INN	MODE	LOAD	
H	H	BRAKE	NORMAL	H
			SHORT	L (Note 1)
H/L	L/H	FORWARD/ REVERSE	NORMAL	H
			SHORT	L (Note 1)
L	L	STANDBY	-	H

(Note 1) Refer to timing chart

2. PO Output Timing Chart

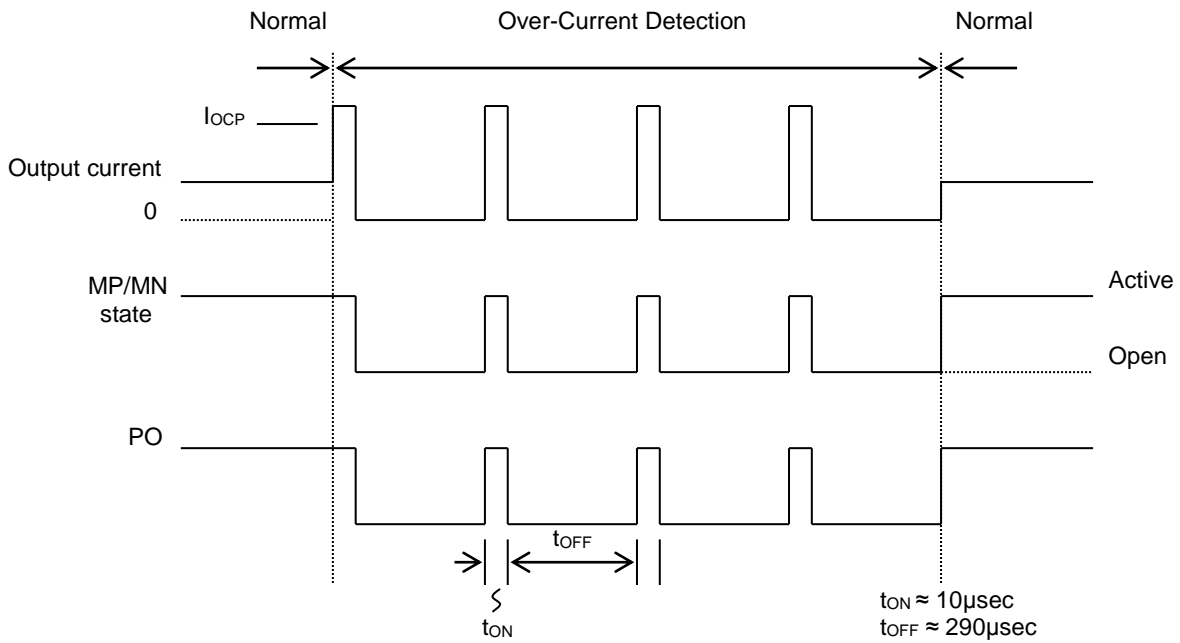

Power Dissipation

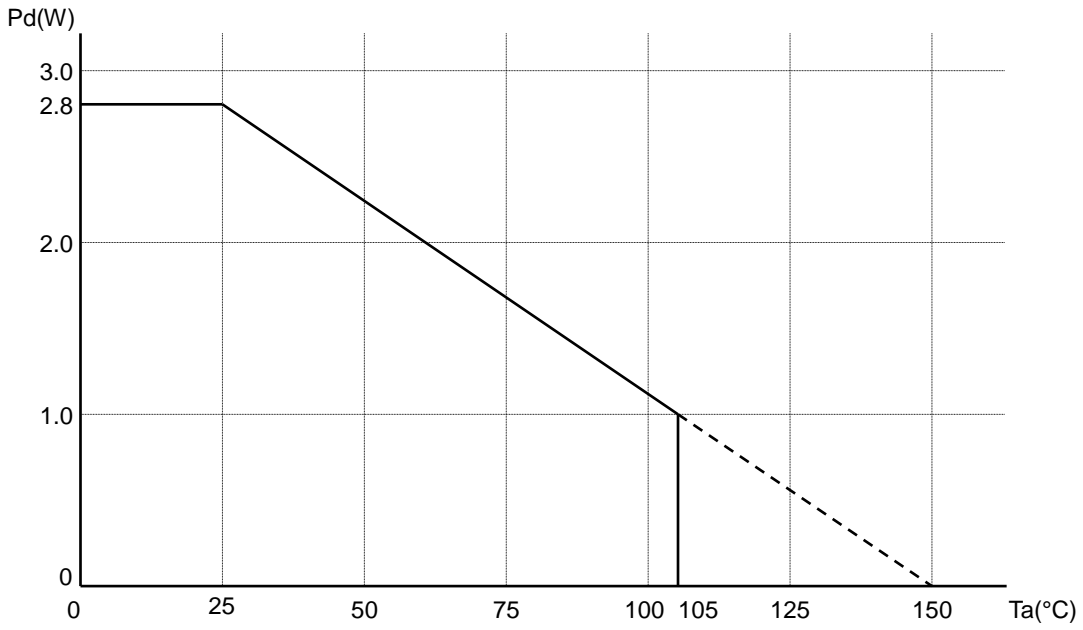

Mounted on a glass epoxy PCB (70mm x 70mm x 1.6mm)
 To use at temperature above Ta=25°C reduce 22.4mW/°C.

I/O Equivalent Circuits

1. INP, INN

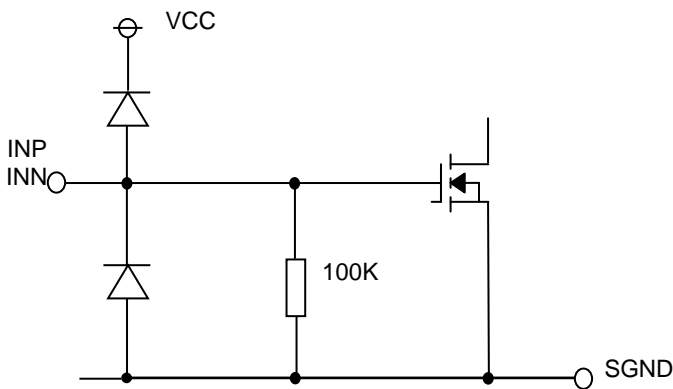

2. PO

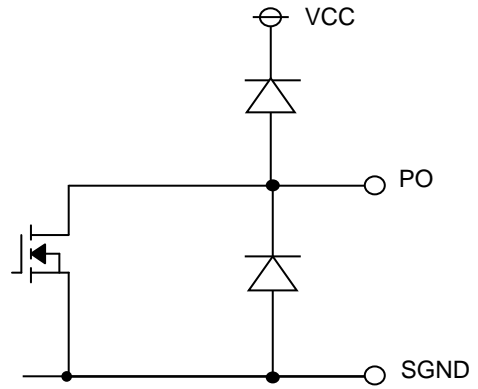

3. MP, MN

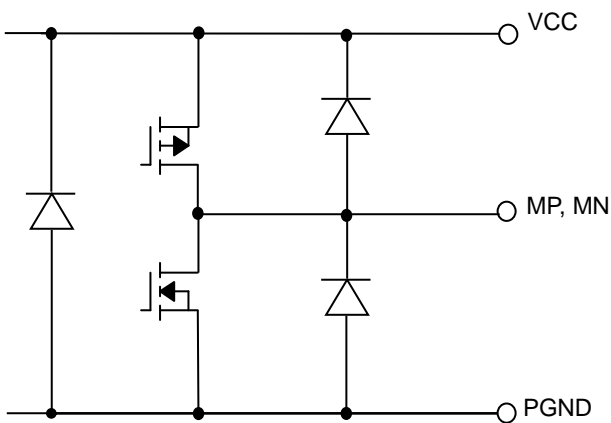

Operational Notes

1. Reverse Connection of Power Supply

Connecting the power supply in reverse polarity can damage the IC. Take precautions against reverse polarity when connecting the power supply, such as mounting an external diode between the power supply and the IC's power supply pins.

2. Power Supply Lines

Design the PCB layout pattern to provide low impedance supply lines. Separate the ground and supply lines of the digital and analog blocks to prevent noise in the ground and supply lines of the digital block from affecting the analog block. Furthermore, connect a capacitor to ground at all power supply pins. Consider the effect of temperature and aging on the capacitance value when using electrolytic capacitors.

3. Ground Voltage

Ensure that no pins are at a voltage below that of the ground pin at any time, even during transient condition.

4. Ground Wiring Pattern

When using both small-signal and large-current ground traces, the two ground traces should be routed separately but connected to a single ground at the reference point of the application board to avoid fluctuations in the small-signal ground caused by large currents. Also ensure that the ground traces of external components do not cause variations on the ground voltage. The ground lines must be as short and thick as possible to reduce line impedance.

5. Thermal Consideration

Should by any chance the power dissipation rating be exceeded the rise in temperature of the chip may result in deterioration of the properties of the chip. In case of exceeding this absolute maximum rating, increase the board size and copper area to prevent exceeding the Pd rating.

6. Recommended Operating Conditions

These conditions represent a range within which the expected characteristics of the IC can be approximately obtained. The electrical characteristics are guaranteed under the conditions of each parameter.

7. Inrush Current

When power is first supplied to the IC, it is possible that the internal logic may be unstable and inrush current may flow instantaneously due to the internal powering sequence and delays, especially if the IC has more than one power supply. Therefore, give special consideration to power coupling capacitance, power wiring, width of ground wiring, and routing of connections.

8. Operation Under Strong Electromagnetic Field

Operating the IC in the presence of a strong electromagnetic field may cause the IC to malfunction.

9. Testing on Application Boards

When testing the IC on an application board, connecting a capacitor directly to a low-impedance output pin may subject the IC to stress. Always discharge capacitors completely after each process or step. The IC's power supply should always be turned off completely before connecting or removing it from the test setup during the inspection process. To prevent damage from static discharge, ground the IC during assembly and use similar precautions during transport and storage.

10. Inter-pin Short and Mounting Errors

Ensure that the direction and position are correct when mounting the IC on the PCB. Incorrect mounting may result in damaging the IC. Avoid nearby pins being shorted to each other especially to ground, power supply and output pin. Inter-pin shorts could be due to many reasons such as metal particles, water droplets (in very humid environment) and unintentional solder bridge deposited in between pins during assembly to name a few.

Operational Notes – continued

11. Unused Input Pins

Input pins of an IC are often connected to the gate of a MOS transistor. The gate has extremely high impedance and extremely low capacitance. If left unconnected, the electric field from the outside can easily charge it. The small charge acquired in this way is enough to produce a significant effect on the conduction through the transistor and cause unexpected operation of the IC. So unless otherwise specified, unused input pins should be connected to the power supply or ground line.

12. Regarding the Input Pin of the IC

This monolithic IC contains P+ isolation and P substrate layers between adjacent elements in order to keep them isolated. P-N junctions are formed at the intersection of the P layers with the N layers of other elements, creating a parasitic diode or transistor. For example (refer to figure below):

When $GND > Pin A$ and $GND > Pin B$, the P-N junction operates as a parasitic diode.
When $GND > Pin B$, the P-N junction operates as a parasitic transistor.

Parasitic diodes inevitably occur in the structure of the IC. The operation of parasitic diodes can result in mutual interference among circuits, operational faults, or physical damage. Therefore, conditions that cause these diodes to operate, such as applying a voltage lower than the GND voltage to an input pin (and thus to the P substrate) should be avoided.

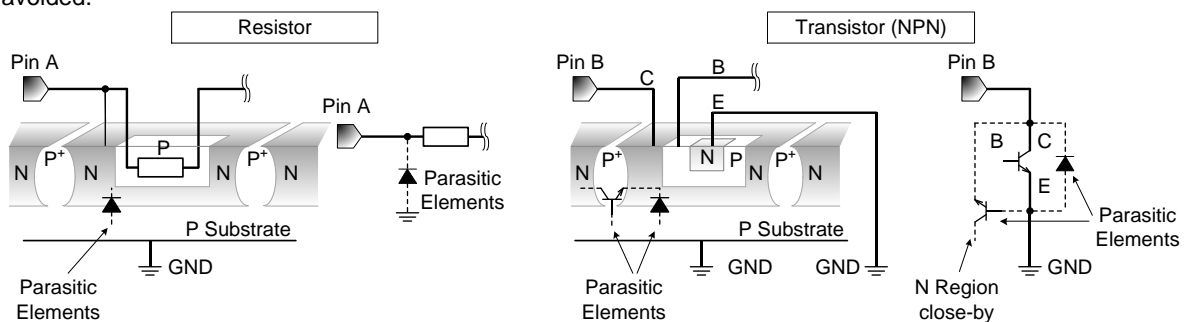

Figure 12. Example of monolithic IC structure

13. Thermal Shutdown Circuit(TSD)

This IC has a built-in thermal shutdown circuit that prevents heat damage to the IC. Normal operation should always be within the IC's power dissipation rating. If however the rating is exceeded for a continued period, the junction temperature (T_j) will rise which will activate the TSD circuit that will turn OFF all output pins. When the T_j falls below the TSD threshold, the circuits are automatically restored to normal operation.

Note that the TSD circuit operates in a situation that exceeds the absolute maximum ratings and therefore, under no circumstances, should the TSD circuit be used in a set design or for any purpose other than protecting the IC from heat damage.

14. Over Current Protection Circuit (OCP)

This IC incorporates an integrated overcurrent protection circuit that is activated when the load is shorted. This protection circuit is effective in preventing damage due to sudden and unexpected incidents. However, the IC should not be used in applications characterized by continuous operation or transitioning of the protection circuit.

This IC has the function of turning off the output when detecting the over current. More than 2.25A(typ) triggers this function. When detecting the over current for 10 μ sec(typ), this function turns off the output(output terminals become Hi-impedance) for 290 μ sec(typ). After the period of turning off time (290 μ sec), the output current recovers. But if the over current is still detected, this function will work again. This function is for protecting IC because of the output short etc. but the continuing detection of over current might cause the extreme heat and damage the IC. It is recommended to change the IC's state to standby mode by the application. And please pay attention to the power dissipation.

15. Slew Rate of Input terminals

Do not apply the voltage to input pin when the VCC is not applied. And when the VCC is applied, the voltage of input pin must not exceed VCC. It is feared that output get malfunction, as input voltage is swept slowly near the H, L threshold voltage. Please pay attention to input slew rate.

16. Back Electromotive Force (BEMF)

There is a possibility that the BEMF is changed by use of the operating condition, environment and the individual characteristics of motor. Please make sure there is no problem of operating the IC even though the BEMF is changed.

17. Over Voltage Lock-out Function

This IC has the function of turning OFF the output when detecting the over voltage. More than 30V (typ) triggers this function. But in the standby mode, this function does not work. Although this IC has over voltage lockout function, the voltage that exceeds absolute maximum ratings might destroy the IC. Please do not exceed the absolute maximum ratings.

Ordering Information

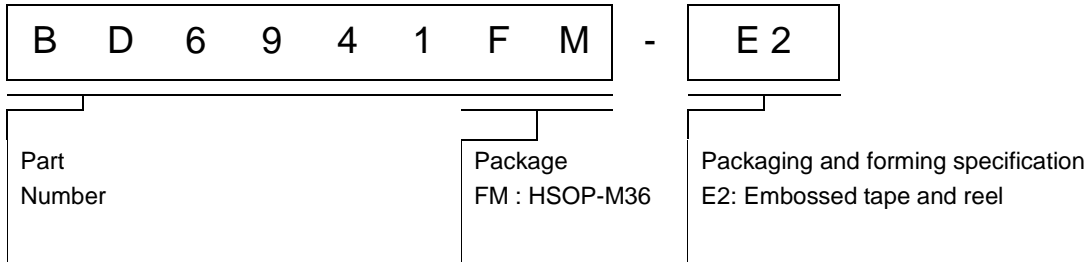

Marking Diagram

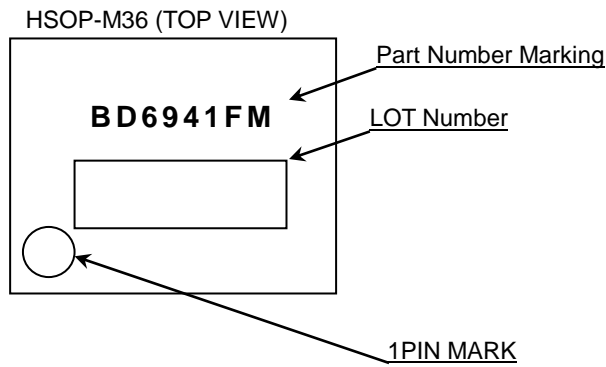

Physical Dimension, Tape and Reel Information

Package Name	HSOP-M36
--------------	----------

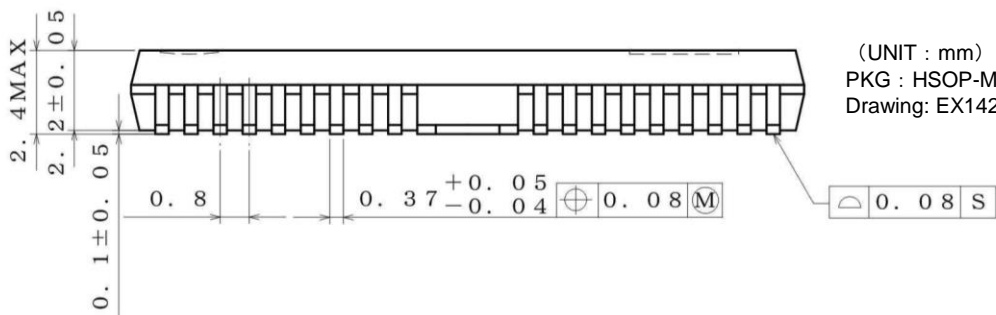
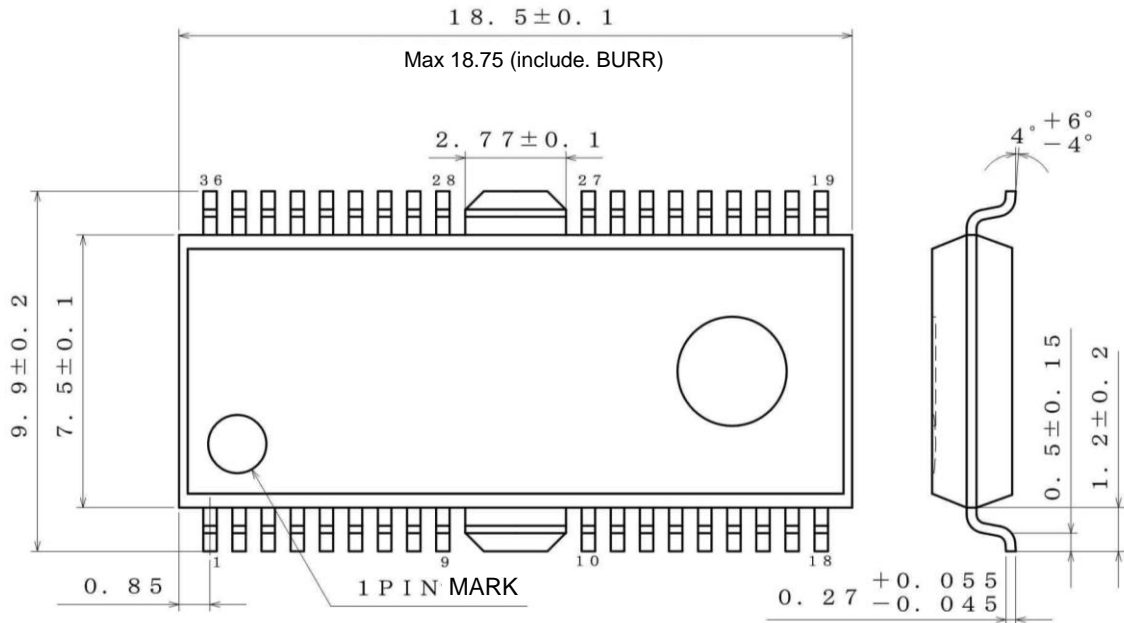

(UNIT : mm)
 PKG : HSOP-M36
 Drawing: EX142-5001

<Tape and Reel information>

Tape	Embossed carrier tape (with dry pack)
Quantity	1500pcs
Direction of feed	E2 (The direction is the 1pin of product is at the upper left when you hold reel on the left hand and you pull out the tape on the right hand)

1pin
 *Order quantity needs to be multiple of the minimum quantity.

Revision History

Date	Revision	Changes
06.Nov.2015	001	New Release

Notice

Precaution on using ROHM Products

- Our Products are designed and manufactured for application in ordinary electronic equipments (such as AV equipment, OA equipment, telecommunication equipment, home electronic appliances, amusement equipment, etc.). If you intend to use our Products in devices requiring extremely high reliability (such as medical equipment ^(Note 1), transport equipment, traffic equipment, aircraft/spacecraft, nuclear power controllers, fuel controllers, car equipment including car accessories, safety devices, etc.) and whose malfunction or failure may cause loss of human life, bodily injury or serious damage to property ("Specific Applications"), please consult with the ROHM sales representative in advance. Unless otherwise agreed in writing by ROHM in advance, ROHM shall not be in any way responsible or liable for any damages, expenses or losses incurred by you or third parties arising from the use of any ROHM's Products for Specific Applications.

(Note1) Medical Equipment Classification of the Specific Applications

JAPAN	USA	EU	CHINA
CLASS III	CLASS III	CLASS II b	CLASS III
CLASS IV		CLASS III	

- ROHM designs and manufactures its Products subject to strict quality control system. However, semiconductor products can fail or malfunction at a certain rate. Please be sure to implement, at your own responsibilities, adequate safety measures including but not limited to fail-safe design against the physical injury, damage to any property, which a failure or malfunction of our Products may cause. The following are examples of safety measures:
 - Installation of protection circuits or other protective devices to improve system safety
 - Installation of redundant circuits to reduce the impact of single or multiple circuit failure
- Our Products are designed and manufactured for use under standard conditions and not under any special or extraordinary environments or conditions, as exemplified below. Accordingly, ROHM shall not be in any way responsible or liable for any damages, expenses or losses arising from the use of any ROHM's Products under any special or extraordinary environments or conditions. If you intend to use our Products under any special or extraordinary environments or conditions (as exemplified below), your independent verification and confirmation of product performance, reliability, etc. prior to use, must be necessary:
 - Use of our Products in any types of liquid, including water, oils, chemicals, and organic solvents
 - Use of our Products outdoors or in places where the Products are exposed to direct sunlight or dust
 - Use of our Products in places where the Products are exposed to sea wind or corrosive gases, including Cl₂, H₂S, NH₃, SO₂, and NO₂
 - Use of our Products in places where the Products are exposed to static electricity or electromagnetic waves
 - Use of our Products in proximity to heat-producing components, plastic cords, or other flammable items
 - Sealing or coating our Products with resin or other coating materials
 - Use of our Products without cleaning residue of flux (even if you use no-clean type fluxes, cleaning residue of flux is recommended); or Washing our Products by using water or water-soluble cleaning agents for cleaning residue after soldering
 - Use of the Products in places subject to dew condensation
- The Products are not subject to radiation-proof design.
- Please verify and confirm characteristics of the final or mounted products in using the Products.
- In particular, if a transient load (a large amount of load applied in a short period of time, such as pulse. is applied, confirmation of performance characteristics after on-board mounting is strongly recommended. Avoid applying power exceeding normal rated power; exceeding the power rating under steady-state loading condition may negatively affect product performance and reliability.
- De-rate Power Dissipation depending on ambient temperature. When used in sealed area, confirm that it is the use in the range that does not exceed the maximum junction temperature.
- Confirm that operation temperature is within the specified range described in the product specification.
- ROHM shall not be in any way responsible or liable for failure induced under deviant condition from what is defined in this document.

Precaution for Mounting / Circuit board design

- When a highly active halogenous (chlorine, bromine, etc.) flux is used, the residue of flux may negatively affect product performance and reliability.
- In principle, the reflow soldering method must be used on a surface-mount products, the flow soldering method must be used on a through hole mount products. If the flow soldering method is preferred on a surface-mount products, please consult with the ROHM representative in advance.

For details, please refer to ROHM Mounting specification

Precautions Regarding Application Examples and External Circuits

1. If change is made to the constant of an external circuit, please allow a sufficient margin considering variations of the characteristics of the Products and external components, including transient characteristics, as well as static characteristics.
2. You agree that application notes, reference designs, and associated data and information contained in this document are presented only as guidance for Products use. Therefore, in case you use such information, you are solely responsible for it and you must exercise your own independent verification and judgment in the use of such information contained in this document. ROHM shall not be in any way responsible or liable for any damages, expenses or losses incurred by you or third parties arising from the use of such information.

Precaution for Electrostatic

This Product is electrostatic sensitive product, which may be damaged due to electrostatic discharge. Please take proper caution in your manufacturing process and storage so that voltage exceeding the Products maximum rating will not be applied to Products. Please take special care under dry condition (e.g. Grounding of human body / equipment / solder iron, isolation from charged objects, setting of Ionizer, friction prevention and temperature / humidity control).

Precaution for Storage / Transportation

1. Product performance and soldered connections may deteriorate if the Products are stored in the places where:
 - [a] the Products are exposed to sea winds or corrosive gases, including Cl₂, H₂S, NH₃, SO₂, and NO₂
 - [b] the temperature or humidity exceeds those recommended by ROHM
 - [c] the Products are exposed to direct sunshine or condensation
 - [d] the Products are exposed to high Electrostatic
2. Even under ROHM recommended storage condition, solderability of products out of recommended storage time period may be degraded. It is strongly recommended to confirm solderability before using Products of which storage time is exceeding the recommended storage time period.
3. Store / transport cartons in the correct direction, which is indicated on a carton with a symbol. Otherwise bent leads may occur due to excessive stress applied when dropping of a carton.
4. Use Products within the specified time after opening a humidity barrier bag. Baking is required before using Products of which storage time is exceeding the recommended storage time period.

Precaution for Product Label

QR code printed on ROHM Products label is for ROHM's internal use only.

Precaution for Disposition

When disposing Products please dispose them properly using an authorized industry waste company.

Precaution for Foreign Exchange and Foreign Trade act

Since concerned goods might be fallen under listed items of export control prescribed by Foreign exchange and Foreign trade act, please consult with ROHM in case of export.

Precaution Regarding Intellectual Property Rights

1. All information and data including but not limited to application example contained in this document is for reference only. ROHM does not warrant that foregoing information or data will not infringe any intellectual property rights or any other rights of any third party regarding such information or data.
2. ROHM shall not have any obligations where the claims, actions or demands arising from the combination of the Products with other articles such as components, circuits, systems or external equipment (including software).
3. No license, expressly or implied, is granted hereby under any intellectual property rights or other rights of ROHM or any third parties with respect to the Products or the information contained in this document. Provided, however, that ROHM will not assert its intellectual property rights or other rights against you or your customers to the extent necessary to manufacture or sell products containing the Products, subject to the terms and conditions herein.

Other Precaution

1. This document may not be reprinted or reproduced, in whole or in part, without prior written consent of ROHM.
2. The Products may not be disassembled, converted, modified, reproduced or otherwise changed without prior written consent of ROHM.
3. In no event shall you use in any way whatsoever the Products and the related technical information contained in the Products or this document for any military purposes, including but not limited to, the development of mass-destruction weapons.
4. The proper names of companies or products described in this document are trademarks or registered trademarks of ROHM, its affiliated companies or third parties.

General Precaution

1. Before you use our Products, you are requested to carefully read this document and fully understand its contents. ROHM shall not be in any way responsible or liable for failure, malfunction or accident arising from the use of any ROHM's Products against warning, caution or note contained in this document.
2. All information contained in this document is current as of the issuing date and subject to change without any prior notice. Before purchasing or using ROHM's Products, please confirm the latest information with a ROHM sales representative.
3. The information contained in this document is provided on an "as is" basis and ROHM does not warrant that all information contained in this document is accurate and/or error-free. ROHM shall not be in any way responsible or liable for any damages, expenses or losses incurred by you or third parties resulting from inaccuracy or errors of or concerning such information.



BD6941FM - Web Page

[Distribution Inventory](#)

Part Number	BD6941FM
Package	HSOP-M36
Unit Quantity	1500
Minimum Package Quantity	1500
Packing Type	Taping
Constitution Materials List	inquiry
RoHS	Yes