

FUNCTIONAL DIAGRAM

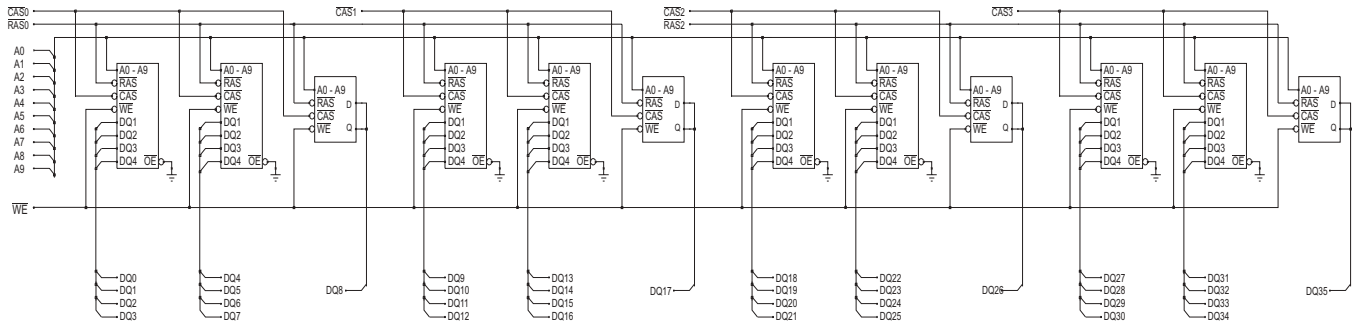

MECHANICAL DIMENSIONS

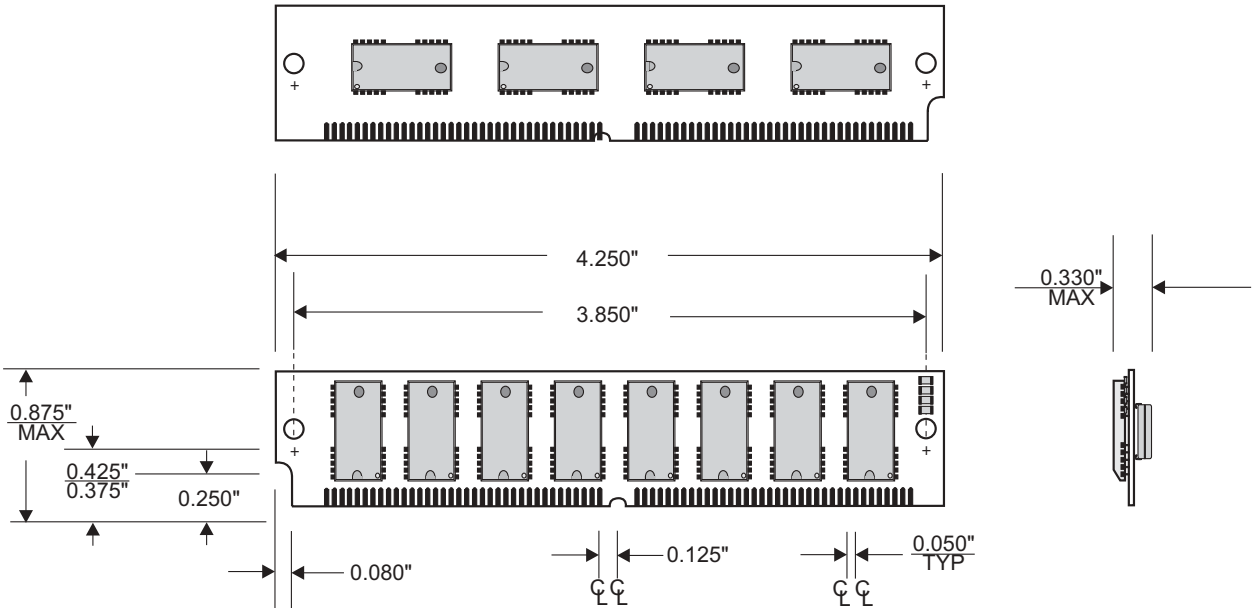

ACCUTEK MICROCIRCUIT CORPORATION
 BUSINESS CENTER at NEWBURYPORT
 2 NEW PASTURE ROAD, SUITE 1
 NEWBURYPORT, MA 01950-4054
 PHONE: 978-465-6200 FAX: 978-462-3396
 E-Mail: sales@accutekmicro.com
 Internet: www.accutekmicro.com

Accutek reserves the right to make changes in specifications at any time and without notice. Accutek does not assume any responsibility for the use of any circuitry described; no circuit patent licenses are implied. Preliminary data sheets contain minimum and maximum limits based upon design objectives, which are subject to change upon full characterization over the specific operating conditions.