

Rev	AWO #	Description	Date	Appr
-		RELEASED	11/30/10	

APPROVED: _____

DATE: _____ TITLE: _____

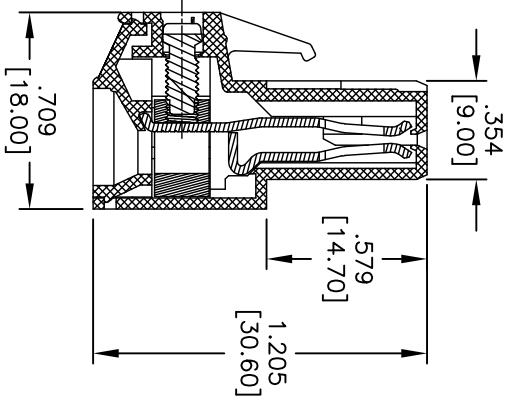
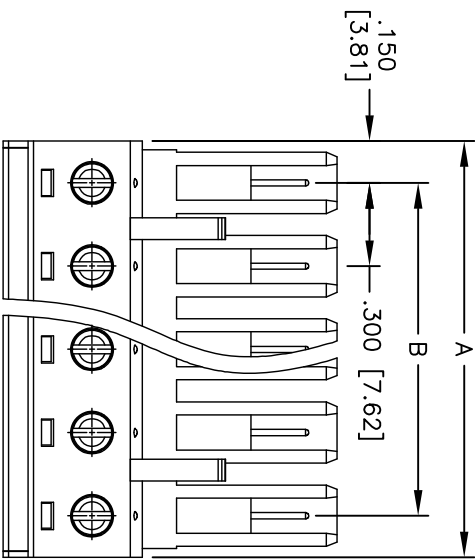
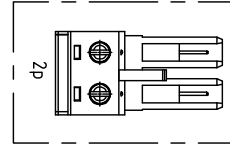
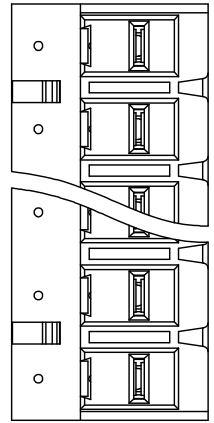

	Dim A	Dim B
2-6P	±.008 [0.20]	±.008 [0.20]
7-12P	±.012 [0.30]	±.012 [0.30]
13-16P	±.016 [0.40]	±.016 [0.40]

Poles: 2 thru 16
 A = .300 [7.62] X No. of Positions
 B = .300 [7.62] X No. of Spaces



UNLESS OTHERWISE SPECIFIED
 ALL DIMENSIONS ARE MM [INCHES]
 TOLERANCES: EXCEPT AS NOTED
 INCHES HOLEES

APPROVALS	DATE
AY	11/30/10
AH	11/30/10

ADAM TECH
 909 Rahway Avenue, Union, NJ 07083
 Phone: 908-687-5000 Fax: 908-687-5710

EURO BLOCK, 300 [7.62] PITCH

SPECIFICATIONS:
 Material: Insulator: Thermoplastic, rated UL 94V-0
 Insulator color: Green
 Clamp: Brass, Nickel plated
 Screw: M3.0, Steel, Zn plated.
 Contact: Copper Alloy, Tin plated.
 Electrical:
 Operation voltage: 300 VAC
 Current rating: 20 Amps
 Mechanical:
 Wire strip length: 7-8mm
 Torque (Lb-in): 4.5
 Wire Range: 10-30 Awg
 Withstanding Voltage: 1.6KV
 Environmental:
 Operating temperature: -40°C to +115°C
 Lead free, RoHS compliant.
 Recommended soldering temp: 235°C for 5 sec.



SIZE	PART NO.	REV.
X	EB42-XX-G	-

REF: S00007T SCALE: NTS SHEET 1 OF 1