



# 512Kx8 MONOLITHIC SRAM

## FEATURES

- Access Times 15, 17, 20ns
- Revolutionary, Center Power/Ground Pinout JEDEC Approved
  - 36 lead Ceramic SOJ (Package 100)
  - 36 lead Ceramic Flat Pack (Package 226)
- Evolutionary, Corner Power/Ground Pinout JEDEC Approved
  - 32 pin Ceramic DIP (Package 300)
  - 32 lead Ceramic SOJ (Package 101)
  - 32 lead Ceramic Thinpack™ Flat Pack (Package 321)
- 32 pin, Rectangular Ceramic Leadless Chip Carrier (Package 601)
- Low Power CMOS
- Low Voltage Operation
  - 3.3V ± 10% Power Supply
- Commercial, Industrial and Military Temperature Range
- TTL Compatible Inputs and Outputs
- Fully Static Operation:
  - No clock or refresh required
- Three State Output

\* This product is subject to change without notice.

### REVOLUTIONARY PINOUT

### EVOLUTIONARY PINOUT

36 FLAT PACK  
36 CSOJ

TOP VIEW

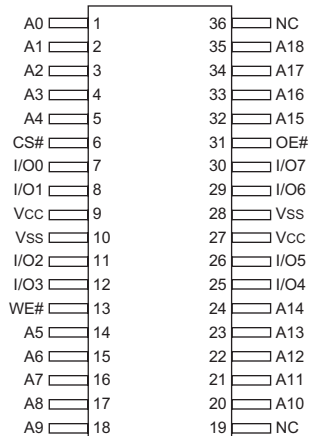

32 DIP  
32 CSOJ (DE)  
32 FLAT PACK (FF)

TOP VIEW

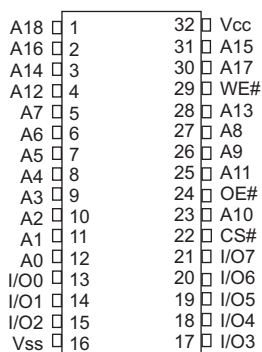

32 CLCC

TOP VIEW

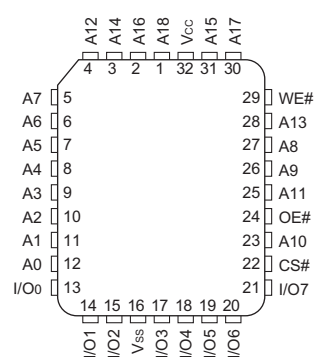

### PIN DESCRIPTION

A0-18	Address Inputs
I/O 0-7	Data Input/Output
CS#	Chip Select
OE#	Output Enable
WE#	Write Enable
Vcc	Power Supply
Vss	Ground



**ABSOLUTE MAXIMUM RATINGS**

Parameter	Symbol	Min	Max	Unit
Operating Temperature	T <sub>A</sub>	-55	+125	°C
Storage Temperature	T <sub>STG</sub>	-65	+150	°C
Signal Voltage Range to GND	V <sub>G</sub>	-0.5	4.6	V
Junction Temperature	T <sub>J</sub>		150	°C
Supply Voltage	V <sub>CC</sub>	-0.5	4.6	V

**TRUTH TABLE**

CS#	OE#	WE#	MODE	DATA I/O	POWER
H	X	X	Standby	High Z	Standby
L	L	H	Read	Data Out	Active
L	X	L	Write	Data In	Active
L	H	H	Out Disable	High Z	Active

**RECOMMENDED OPERATING CONDITIONS**

Parameter	Symbol	Min	Max	Unit
Supply Voltage	V <sub>CC</sub>	3.0	3.6	V
Input High Voltage	V <sub>IH</sub>	2.2	V <sub>CC</sub> + 0.3	V
Input Low Voltage	V <sub>IL</sub>	-0.3	+0.8	V
Operating Temp. (Mil)	T <sub>A</sub>	-55	+125	°C

**CAPACITANCE**

T<sub>A</sub> = +25°C

Parameter	Symbol	Conditions	Max	Unit
Input capacitance	C <sub>IN</sub>	V <sub>IN</sub> = 0 V, f = 1.0 MHz	12	pF
Output capacitance	C <sub>OUT</sub>	V <sub>OUT</sub> = 0 V, f = 1.0 MHz	12	pF

This parameter is guaranteed by design but not tested.

**DC CHARACTERISTICS - CMOS COMPATIBLE**

V<sub>CC</sub> = 5.0V, GND = 0V, -55°C ≤ T<sub>A</sub> ≤ 125°C

Parameter	Symbol	Conditions	Min	Max	Unit
Input Leakage Current	I <sub>LI</sub>	V <sub>CC</sub> = 3.6, V <sub>IN</sub> = GND to V <sub>CC</sub>		10	μA
Output Leakage Current	I <sub>LO</sub>	CS# = V <sub>IH</sub> , OE# = V <sub>IH</sub> , V <sub>OUT</sub> = GND to V <sub>CC</sub>		10	μA
Operating Supply Current	I <sub>CC</sub>	CS# = V <sub>IH</sub> , OE# = V <sub>IH</sub> , f = 5MHz, V <sub>CC</sub> = 3.6		100	mA
Standby Current	I <sub>SS</sub>	CS# = V <sub>IH</sub> , OE# = V <sub>IH</sub> , f = 5MHz, V <sub>CC</sub> = 3.6		50	mA
Output Low Voltage	V <sub>OL</sub>	I <sub>OL</sub> = 4.0mA		0.4	V
Output High Voltage	V <sub>OH</sub>	I <sub>OH</sub> = -4.0mA	2.4		V



**AC CHARACTERISTICS**

V<sub>CC</sub> = 5.0V, GND = 0V, -55°C ≤ T<sub>A</sub> ≤ 125°C

Parameter Read Cycle	Symbol	-15		-17		-20		Unit
		Min	Max	Min	Max	Min	Max	
Read Cycle Time	t <sub>RC</sub>	15		17		20		ns
Address Access Time	t <sub>AA</sub>		15		17		20	ns
Output Hold from Address Change	t <sub>OH</sub>	0		0		0		ns
Chip Select Access Time	t <sub>ACS</sub>		15		17		20	ns
Output Enable to Output Valid	t <sub>OE</sub>		8		8		10	ns
Chip Select to Output in Low Z	t <sub>CLZ1</sub>	1		1		1		ns
Output Enable to Output in Low Z	t <sub>OLZ1</sub>	0		0		0		ns
Chip Disable to Output in High Z	t <sub>CHZ1</sub>		8		8		10	ns
Output Disable to Output in High Z	t <sub>OHZ1</sub>		8		8		10	ns

1. This parameter is guaranteed by design but not tested.

**AC CHARACTERISTICS**

V<sub>CC</sub> = 5.0V, GND = 0V, -55°C ≤ T<sub>A</sub> ≤ 125°C

Parameter Write Cycle	Symbol	-15		-17		-20		Unit
		Min	Max	Min	Max	Min	Max	
Write Cycle Time	t <sub>WC</sub>	15		17		20		ns
Chip Select to End of Write	t <sub>CW</sub>	12		12		14		ns
Address Valid to End of Write	t <sub>AW</sub>	12		12		14		ns
Data Valid to End of Write	t <sub>DW</sub>	9		9		10		ns
Write Pulse Width	t <sub>WP</sub>	12		14		14		ns
Address Setup Time	t <sub>AS</sub>	0		0		0		ns
Address Hold Time	t <sub>AH</sub>	0		0		0		ns
Output Active from End of Write	t <sub>OW1</sub>	2		3		3		ns
Write Enable to Output in High Z	t <sub>WHZ1</sub>		8		8		9	ns
Data Hold Time	t <sub>DH</sub>	0		0		0		ns

1. This parameter is guaranteed by design but not tested.

**AC TEST CIRCUIT**

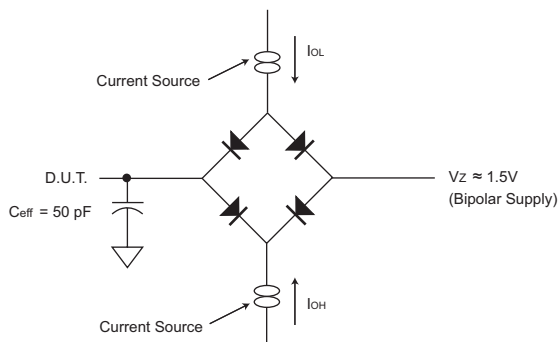

**AC TEST CONDITIONS**

Parameter	Typ	Unit
Input Pulse Levels	V <sub>IL</sub> = 0, V <sub>IH</sub> = 2.5	V
Input Rise and Fall	5	ns
Input and Output Reference Level	1.5	V
Output Timing Reference Level	1.5	V

Notes:  
 V<sub>Z</sub> is programmable from -2V to +7V.  
 I<sub>OL</sub> & I<sub>OH</sub> programmable from 0 to 16mA.  
 Tester Impedance Z<sub>0</sub> = 75Ω.  
 V<sub>Z</sub> is typically the midpoint of V<sub>OH</sub> and V<sub>OL</sub>.  
 I<sub>OL</sub> & I<sub>OH</sub> are adjusted to simulate a typical resistive load circuit.  
 ATE tester includes jig capacitance.



**TIMING WAVEFORM - READ CYCLE**

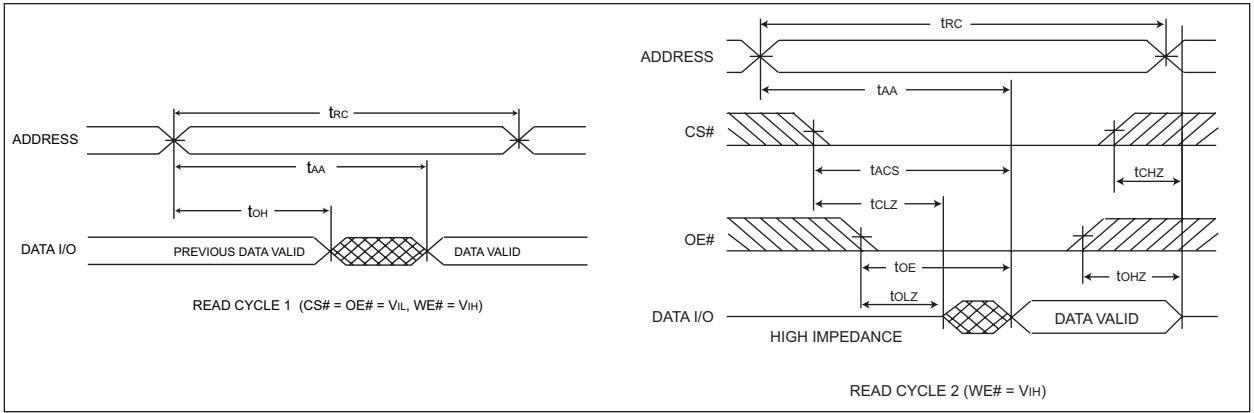

**WRITE CYCLE - WE# CONTROLLED**

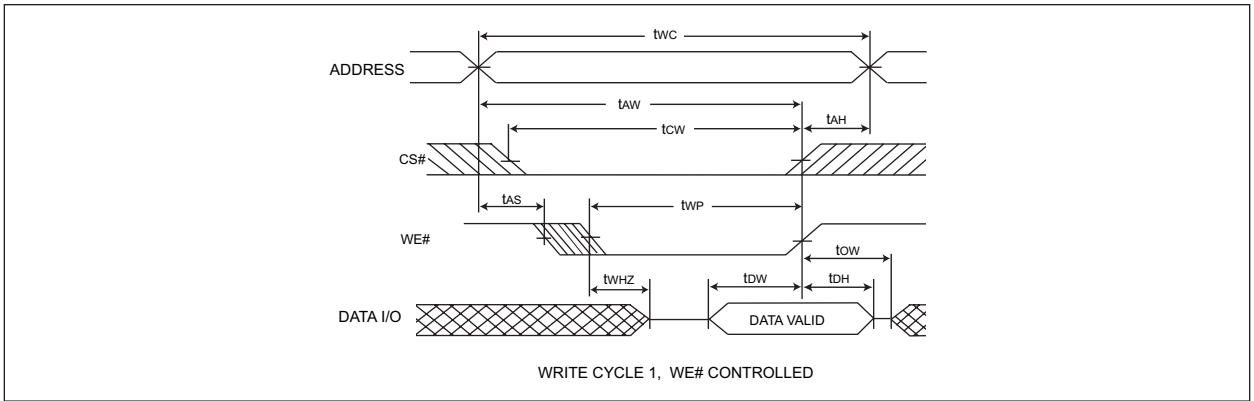

**WRITE CYCLE - CS# CONTROLLED**

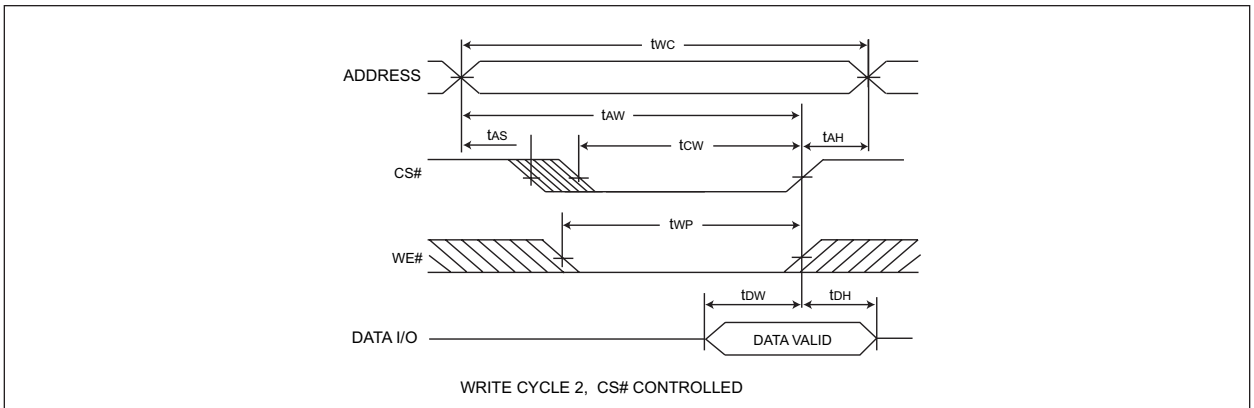



**PACKAGE 100: 36 LEAD, CERAMIC SOJ**

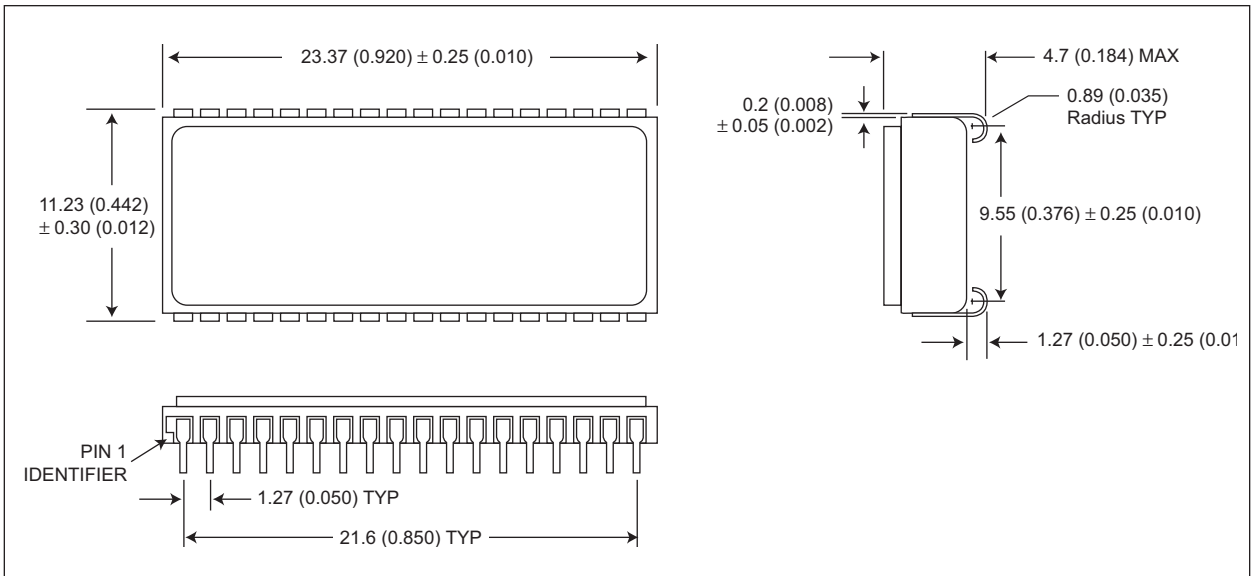

ALL LINEAR DIMENSIONS ARE MILLIMETERS AND PARENTHETICALLY IN INCHES

**PACKAGE 101: 32 LEAD, CERAMIC SOJ**

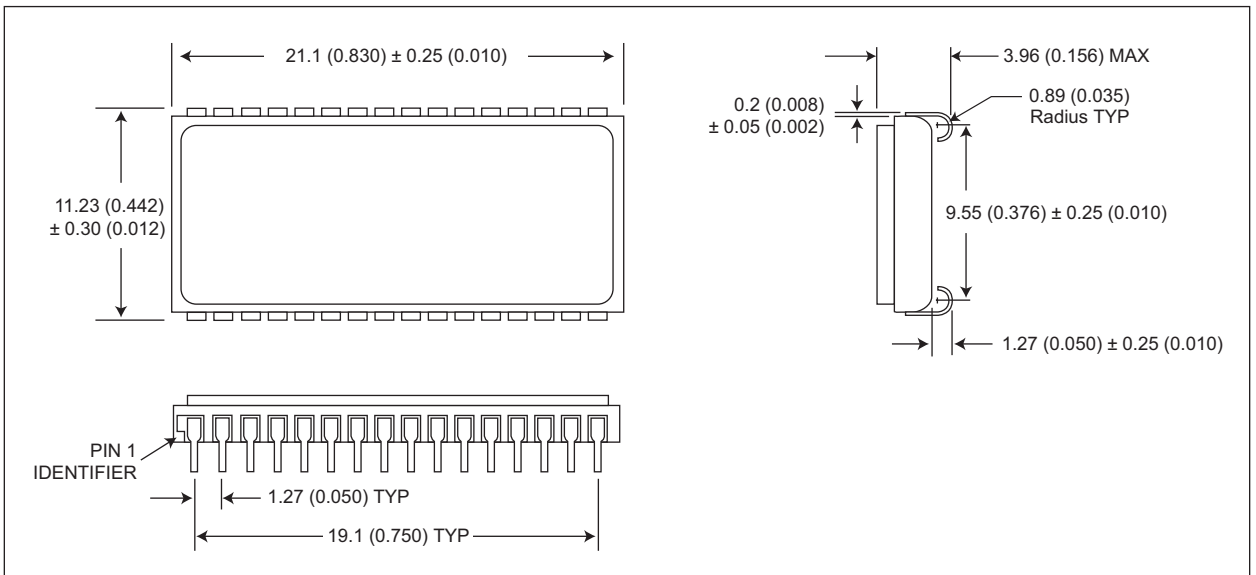

ALL LINEAR DIMENSIONS ARE MILLIMETERS AND PARENTHETICALLY IN INCHES



PACKAGE 321: 32 PIN CERAMIC THINPACK™ FLATPACK

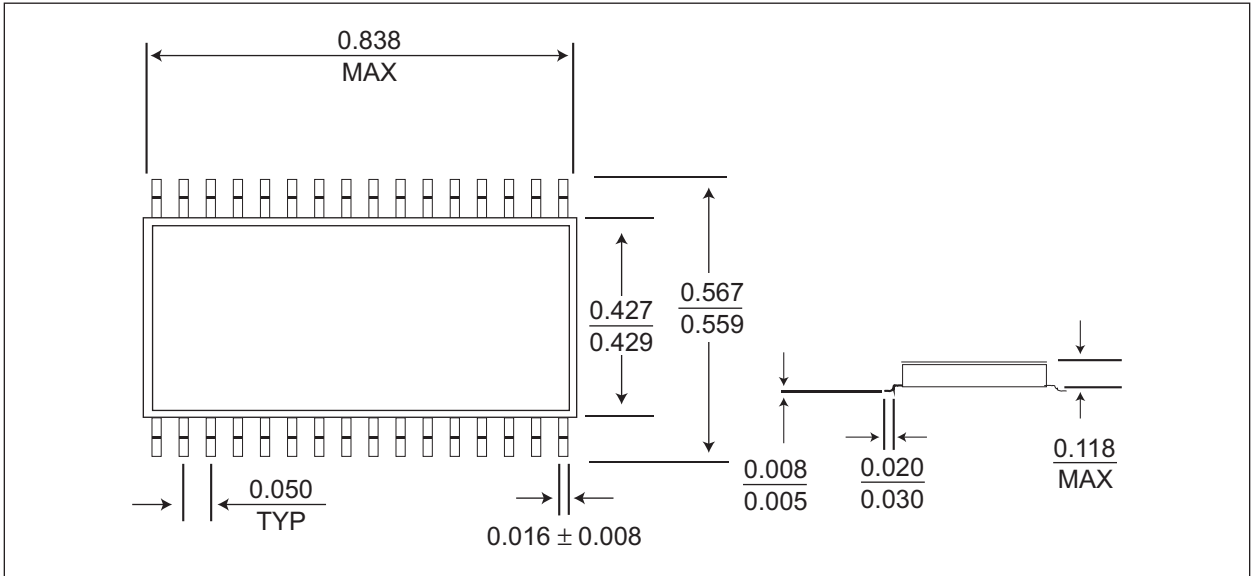

ALL LINEAR DIMENSIONS ARE MILLIMETERS AND PARENTHETICALLY IN INCHES

PACKAGE 226: 36 LEAD, CERAMIC FLAT PACK

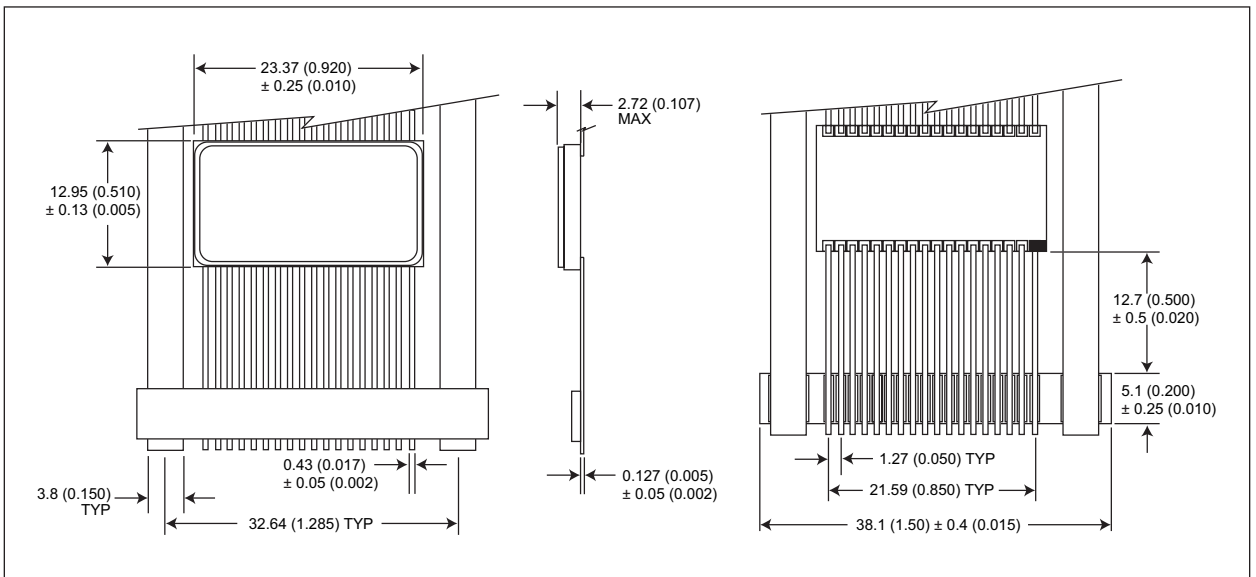

ALL LINEAR DIMENSIONS ARE MILLIMETERS AND PARENTHETICALLY IN INCHES



**PACKAGE 300: 32 PIN, CERAMIC DIP, SINGLE CAVITY SIDE BRAZED**

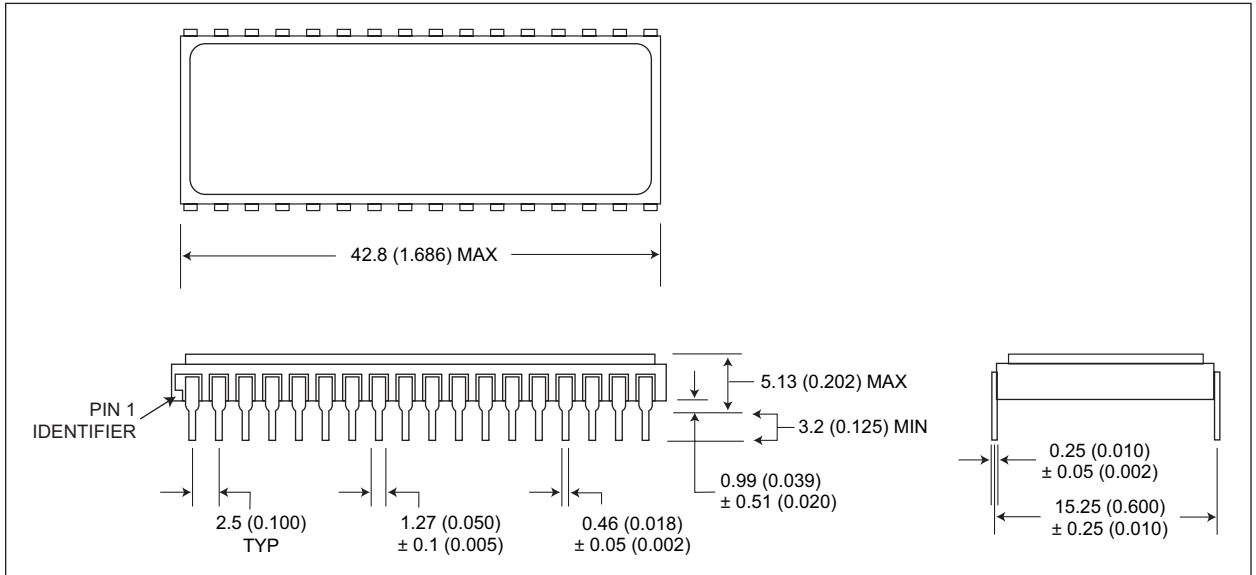

ALL LINEAR DIMENSIONS ARE MILLIMETERS AND PARENTHETICALLY IN INCHES

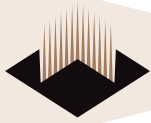

PACKAGE 601: 32 PIN, RECTANGULAR CERAMIC LEADLESS CHIP CARRIER

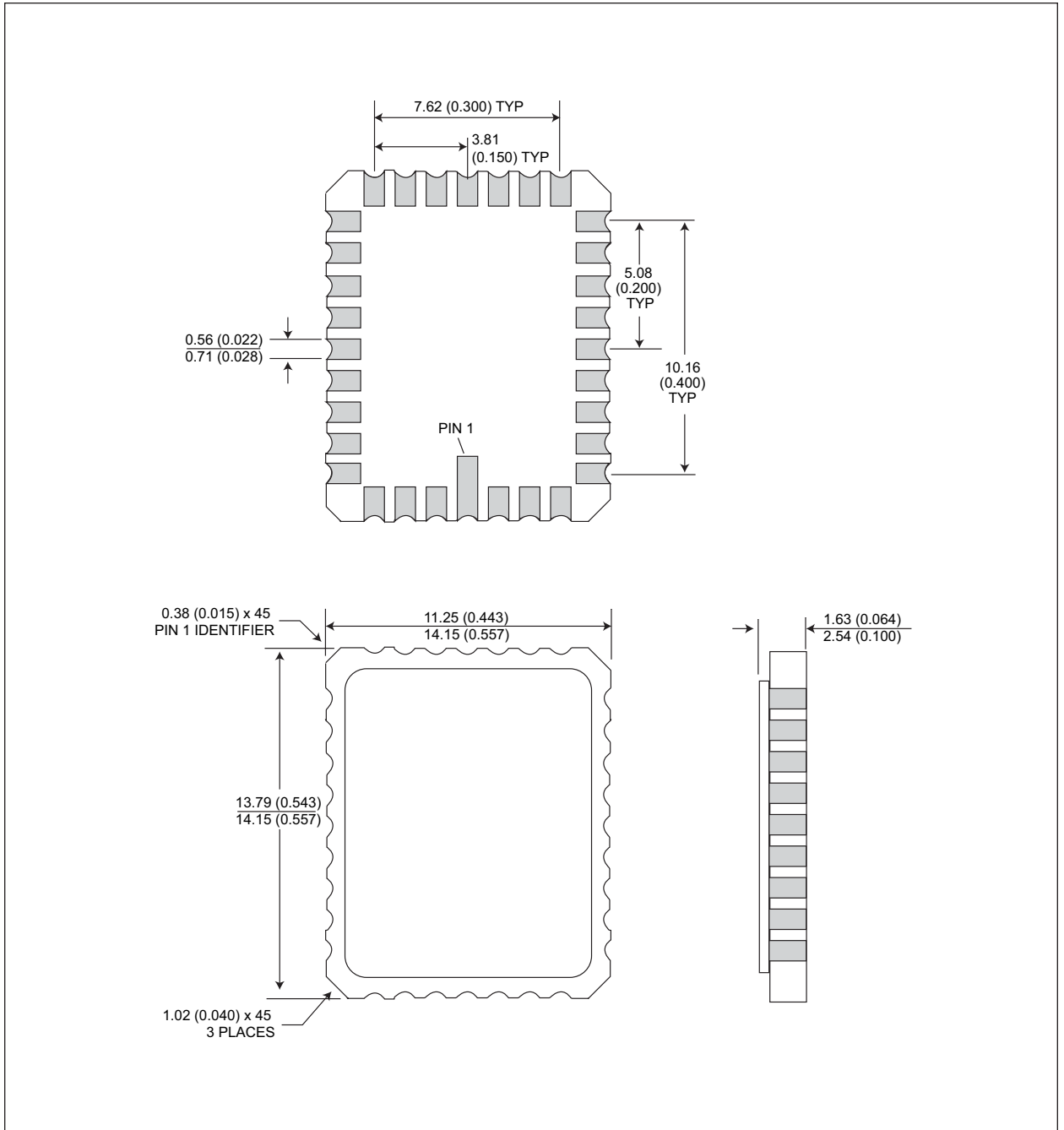

ALL LINEAR DIMENSIONS ARE MILLIMETERS AND PARENTHETICALLY IN INCHES





ORDERING INFORMATION

W M S 512K 8 V - XXX X X X

WHITE ELECTRONIC DESIGNS CORP.

MONOLITHIC

SRAM

ORGANIZATION, 512K x 8

LOW VOLTAGE SUPPLY 3.3V ± 10%

ACCESS TIME (ns)

PACKAGE:

- C = 32 pin Ceramic 0.600" DIP (Package 300)
- CL = 32 pin Rectangular Ceramic Leadless Chip Carrier (Package 601)
- DE = 32 Lead Ceramic SOJ (Package 101) Evolutionary
- DJ = 36 Lead Ceramic SOJ (Package 100)
- F = 36 Lead Ceramic Flat Pack (Package 226)
- FF = 32 Lead Ceramic Thinpack™ Flat Pack (Package 321)

DEVICE GRADE:

- M = Military Screened    -55°C ≤ T<sub>A</sub> ≤ 125°C
- I = Industrial            -40°C ≤ T<sub>A</sub> ≤ 85°C
- C = Commercial         0°C ≤ T<sub>A</sub> ≤ 70°C

LEAD FINISH:

- Blank = Gold plated leads
- A = Solder dip leads