

## 7/8" (22.2 mm) Ten Turn Wirewound Upper Grade Precision Potentiometer

**FEATURES**

- Bushing mount and servo mount designs are available
- Large ohmic value range: 15 Ω to 100 kΩ
- Dual gang configuration
- Improved linearity available
- Long life > 2 million shaft revolutions
- Material categorization: for definitions of compliance please see [www.vishay.com/doc?99912](http://www.vishay.com/doc?99912)

QUICK REFERENCE DATA	
Sensor type	ROTATIONAL, multi turn wirewound
Output type	Output by turrets
Market appliance	Professional
Dimensions	7/8" (22.2 mm)

ELECTRICAL SPECIFICATIONS		
PARAMETER	STANDARD	SPECIAL
Total resistance Tolerance: 100 Ω and above Below 100 Ω	15 Ω to 100 kΩ ± 3 % ± 5 %	15 Ω to 150 kΩ ± 1 % ± 3 %
Linearity (independent) 15 Ω to 50 Ω 50 Ω to 1 kΩ 1 kΩ to 5 kΩ 5 kΩ and above	<b>STANDARD</b> ± 0.25 % ± 0.25 % ± 0.25 % ± 0.25 %	<b>BEST PRACTICAL</b> ± 0.15 % ± 0.10 % ± 0.075 % ± 0.05 %
Noise	100 Ω ENR	
Electrical rotation	3600° +4° -0°	
Power rating: Additional sections	2.0 W at 70 °C ambient derated to zero at 125 °C 75 % of the rating of section 1 (1.5 W at 70 °C)	
Insulation resistance	1000 MΩ minimum 500 V <sub>DC</sub>	
Dielectric strength	1000 V <sub>RMS</sub> , 60 Hz	
Absolute minimum resistance	Linearity x total resistance or 0.5 Ω whichever is greater	
End Voltage	Linearity x total applied voltage for total resistance above 20 Ω, 2.0 % of applied voltage for 20 Ω and below	
Phasing (CCW end points)	Additional sections phased to section 1 within ± 2°	
Taps (extra)	54 available as special, standard tolerance ± 2°	

ORDERING INFORMATION														
5	0	2	S	1	2	0	3	2	0	3	X	X	X	X
MODEL		STYLE		GANGS		OHMIC VALUE GANGS N° 1			OHMIC VALUE GANGS N° 2			SPECIAL REQUEST		
500 501 502		B: bushing S: servo		1 2		470 = 47 Ω 222 = 2,200 Ω 103 = 10 kΩ For ohmic value range see electrical specification			470 = 47 Ω 222 = 2,200 Ω 103 = 10 kΩ For ohmic value range see electrical specification			Custom reference		

PART NUMBER DESCRIPTION (for information only)					
502-	2	1	203	203	XXXX
MODEL	STYLE	GANGS	OHMIC VALUE GANGS N° 1	OHMIC VALUE GANGS N° 2	SPECIAL
	B = 1 S = 2				

**DIMENSIONS** in inches (millimeters)

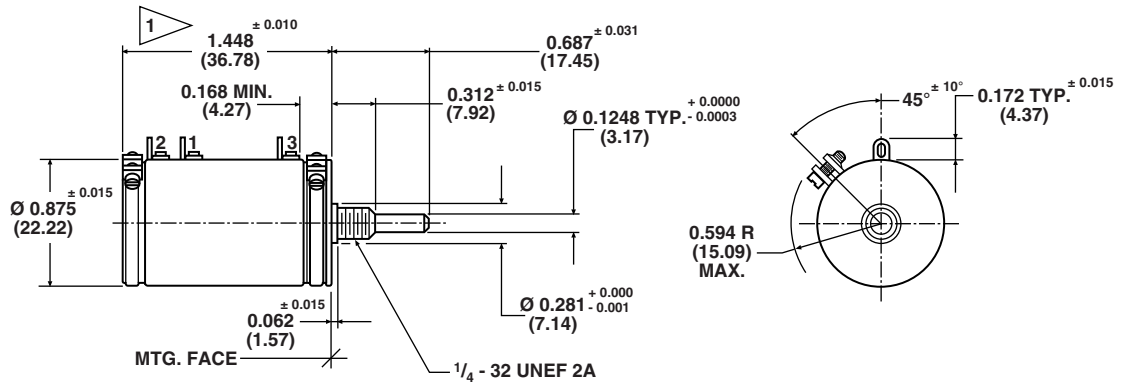
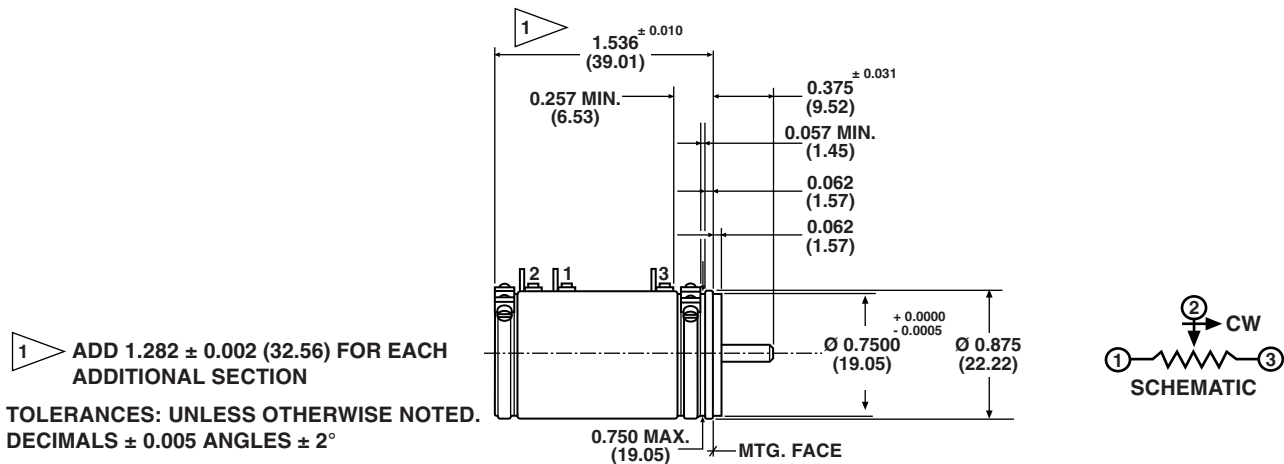
**BUSHING MOUNT: 502B/502-1**

**SERVO MOUNT: 502S/502-2**

**MECHANICAL SPECIFICATIONS**

PARAMETER		
Rotation	3600° +10° -0°	
Bearing type	<b>SERVO</b> Ball bearing	<b>BUSHING MOUNT</b> Sleeve bearing
Torque (maximums)	<b>STARTING</b>	<b>RUNNING</b>
Servo section 1	0.4 oz. - in (28.8 g - cm)	0.3 oz. - in (21.6 g - cm)
Bushing section 1	0.5 oz. - in (36.0 g - cm)	0.4 oz. - in (28.8 g - cm)
Each additional section	0.3 oz. - in (21.6 g - cm)	0.2 oz. - in (14.4 g - cm)
Mechanical runout (maximums):	<b>SERVO</b>	<b>BUSHING</b>
Shaft runout (TIR)	0.002" (0.05 cm)	0.002" (0.05 cm)
Pilot dia. runout (TIR)	0.002" (0.05 cm)	0.002" (0.05 cm)
Lateral runout (TIR)	0.002" (0.05 cm)	0.005" (0.13 cm)
Shaft end play	0.005" (0.13 cm)	0.005" (0.13 cm)
Shaft radial play	0.002" (0.05 cm)	0.003" (0.08 cm)
Weight:		
Single section	1.20 oz. (34.0 g)	
Each additional section	0.80 oz. (22.7 g)	
Stop strength	100 oz. - in, static (7.2 kg - cm)	
Ganging	2 sections, terminal alignment, added sections, within ± 10° of section 1 terminals	
Moment of inertia	0.45 g - cm <sup>2</sup> per section maximum	



MATERIAL SPECIFICATIONS	
Housing	Phenolic (black) glass filled
Lids	Aluminum, anodized
Shaft	Stainless steel, non-magnetic, non-passivated
Terminals	Brass, plated for solderability
Clamp ring	Stainless steel
Bushing mounting hardware	Steel, nickel plated
Lockwasher internal tooth:	Brass, nickel plated
Panel nut:	Brass, nickel plated

ENVIRONMENTAL SPECIFICATIONS	
Vibration	15 g thru 2000 CPS
Shock	50 g
Salt Spray	96 h
Rotational Life	2 million shaft revolutions
Load Life	900 h
Operating Temperature Range	-55 °C to +125 °C

**Note**

- Nothing stated herein shall be construed as a guarantee of quality or durability

MARKING	
Unit identification	Units shall be marked with Vishay spectrol name and model no, resistance and resistance tolerance, linearity, terminal identification, and date code. Example of a marking for a standard part: 502-11050

RESISTANCE ELEMENT DATA					
STANDARD RESISTANCE VALUES (Ω)	RESOLUTION (%)	OHMS PER TURN	MAXIMUM CURRENT AT 70 °C AMBIENT (mA)	MAXIMUM VOLTAGE ACROSS COIL (V)	WIRE TEMP. COEF. (ppm/°C)
15	0.088	0.013	365	5.48	800
20	0.066	0.013	316	6.32	800
50	0.050	0.025	200	10.0	800
100	0.050	0.050	141	14.1	180
200	0.049	0.098	100	20.0	20
500	0.037	0.185	63.2	31.6	20
1K	0.034	0.339	44.7	44.7	20
2K	0.029	0.571	31.6	63.2	20
5K	0.023	1.173	20.0	100	20
10K	0.017	1.731	14.1	141	20
20K	0.016	3.142	10.0	200	20
50K	0.011	5.639	6.32	316	20
100K	0.010	10.325	4.47	447	20
150K	0.010	14.170	3.65	548	20

**POWER RATING CHART**

(Ratings for cup No. 1. Additional cups 75 % of values shown)

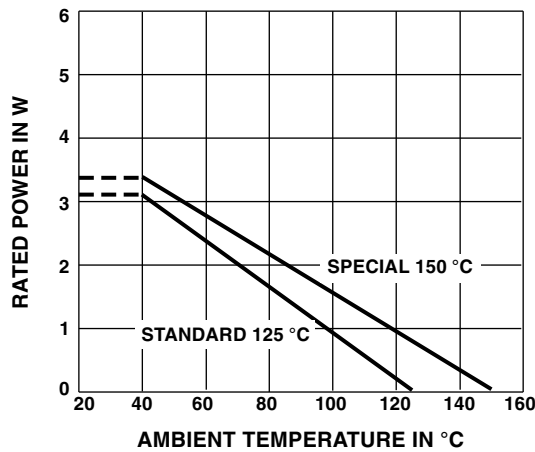



## Disclaimer

ALL PRODUCT, PRODUCT SPECIFICATIONS AND DATA ARE SUBJECT TO CHANGE WITHOUT NOTICE TO IMPROVE RELIABILITY, FUNCTION OR DESIGN OR OTHERWISE.

Vishay Intertechnology, Inc., its affiliates, agents, and employees, and all persons acting on its or their behalf (collectively, "Vishay"), disclaim any and all liability for any errors, inaccuracies or incompleteness contained in any datasheet or in any other disclosure relating to any product.

Vishay makes no warranty, representation or guarantee regarding the suitability of the products for any particular purpose or the continuing production of any product. To the maximum extent permitted by applicable law, Vishay disclaims (i) any and all liability arising out of the application or use of any product, (ii) any and all liability, including without limitation special, consequential or incidental damages, and (iii) any and all implied warranties, including warranties of fitness for particular purpose, non-infringement and merchantability.

Statements regarding the suitability of products for certain types of applications are based on Vishay's knowledge of typical requirements that are often placed on Vishay products in generic applications. Such statements are not binding statements about the suitability of products for a particular application. It is the customer's responsibility to validate that a particular product with the properties described in the product specification is suitable for use in a particular application. Parameters provided in datasheets and / or specifications may vary in different applications and performance may vary over time. All operating parameters, including typical parameters, must be validated for each customer application by the customer's technical experts. Product specifications do not expand or otherwise modify Vishay's terms and conditions of purchase, including but not limited to the warranty expressed therein.

Hyperlinks included in this datasheet may direct users to third-party websites. These links are provided as a convenience and for informational purposes only. Inclusion of these hyperlinks does not constitute an endorsement or an approval by Vishay of any of the products, services or opinions of the corporation, organization or individual associated with the third-party website. Vishay disclaims any and all liability and bears no responsibility for the accuracy, legality or content of the third-party website or for that of subsequent links.

Except as expressly indicated in writing, Vishay products are not designed for use in medical, life-saving, or life-sustaining applications or for any other application in which the failure of the Vishay product could result in personal injury or death. Customers using or selling Vishay products not expressly indicated for use in such applications do so at their own risk. Please contact authorized Vishay personnel to obtain written terms and conditions regarding products designed for such applications.

No license, express or implied, by estoppel or otherwise, to any intellectual property rights is granted by this document or by any conduct of Vishay. Product names and markings noted herein may be trademarks of their respective owners.