

## T1000 Series UPS

### INSTALLATION AND OPERATION MANUAL

SINGLE PHASE - 5.2 & 6 KVA



**Rackmount  
Configuration**



**Tower  
Configuration**

Part # 91074-005  
March 2016

Manufactured in the USA



## Product Use and Warranty Restrictions

The Toshiba products listed in this document are intended for usage in general electronics applications (computer, personal equipment, office equipment, measuring equipment, industrial robotics, domestic appliances, etc.). These Toshiba products are neither intended nor warranted for usage in equipment that requires extraordinarily high quality and/or reliability or where a malfunction or failure may cause loss of human life or bodily injury (Unintended Usage). Unintended Usage includes atomic energy control instruments, airplane or spaceship instruments, transportation instruments, traffic signal instruments, combustion control instruments, life-support equipment, all types of safety devices, etc. Unintended Usage of Toshiba products listed in this document shall be made at the customer's own risk.

### NOTICE

**PLEASE INFORM A TOSHIBA INTERNATIONAL CORPORATION REPRESENTATIVE IN  
CASE OF INCONSISTENCIES, OMISSIONS, OR QUESTIONS.**

The instructions contained in this manual are not intended to cover all of the details or variations in equipment, or to provide for every possible contingency concerning installation, operation, or maintenance. Should further information be required or if problems arise which are not covered sufficiently, contact your Toshiba sales office.

The contents of this instruction manual shall not become a part of or modify any prior or existing agreement, commitment, or relationship. The sales contract contains the entire obligation of Toshiba International Corporation/Social Infrastructure Systems Group/Power Electronics Division/UPS Business Unit, hereafter referred to as Toshiba UPS. The warranty contained in the contract between the parties is the sole warranty of Toshiba UPS and any statements contained herein DO NOT create new warranties or modify the existing warranty.

Any electrical or mechanical modifications to this equipment without prior written consent of Toshiba UPS will void all warranties and may void the UL/CUL listing. Unauthorized modifications can also result in personal injury, loss of life, or destruction of the equipment.

### QUALIFIED PERSONNEL ONLY

Qualified Personnel are those who have the skills and knowledge relating to the construction, installation, operation, and maintenance of the electrical equipment and have received safety training on the hazards involved (Refer to the latest edition of NFPA 70E for additional safety requirements).

**UNINTERRUPTIBLE POWER SYSTEM (UPS)**

Please complete the following information and retain for your records.

Unless otherwise specified, the warranty period for the UPS or UPS part is 36 months from the shipment date (see Toshiba International Corporation bill of lading).

Unless otherwise specified, the warranty period for a UPS battery is 24 months from the shipment date (see Toshiba International Corporation bill of lading).

|                   |       |
|-------------------|-------|
| JOB NUMBER        | _____ |
| MODEL NUMBER      | _____ |
| SERIAL NUMBER     | _____ |
| APPLICATION       | _____ |
| SHIPMENT DATE     | _____ |
| INSTALLATION DATE | _____ |
| INSPECTED BY      | _____ |



## Purpose

This manual provides information on how to safely install your Toshiba International Corporation power electronics product. This manual includes a section of general safety instructions that describes the warning labels and symbols that are used throughout the manual. Read the manual completely before installing, operating, or performing maintenance on this equipment.

This manual and the accompanying drawings should be considered a permanent part of the equipment and should be readily available for reference and review. Dimensions shown in the manual are in metric and/or the English customary equivalent.

Toshiba International Corporation reserves the right, without prior notice, to update information, make product changes, or discontinue any product or service identified in this publication.

Toshiba is a registered trademark of the Toshiba Corporation. All other product or trade references appearing in this manual are registered trademarks of their respective owners.

Toshiba International Corporation shall not be liable for direct, indirect, special, or consequential damages resulting from the use of the information contained within this manual.

This manual is copyrighted. No part of this manual may be photocopied or reproduced in any form without the prior written consent of Toshiba International Corporation.

© Copyright 2016 Toshiba International Corporation  
All rights reserved.  
Printed in the U.S.A.

## Toshiba Customer Support Center

Contact the Toshiba Customer Support Center for assistance with application information or for any problems that you may experience with your Uninterruptible Power System (UPS).

### **Toshiba Customer Support Center**

8 a.m. to 5 p.m. (CST) – Monday through Friday  
USA Toll Free (877) 867-8773 – Field Service Tech Support  
USA Toll Free (855) 803-7087 – Pre-sales Application Support  
Fax (713) 896-5212  
*Email: [ToshibaUPS@tic.toshiba.com](mailto:ToshibaUPS@tic.toshiba.com)*

You may also contact Toshiba by writing to:

**TOSHIBA INTERNATIONAL CORPORATION**  
**SOCIAL INFRASTRUCTURE SYSTEMS GROUP**  
**POWER ELECTRONICS DIVISION - UPS**  
13131 West Little York Road  
Houston, Texas 77041-9990  
Attn: T1000 Product Manager

For further information on Toshiba products and services, please visit our website at:

**[www.toshiba.com/tic/industrial/uninterruptible-power-systems](http://www.toshiba.com/tic/industrial/uninterruptible-power-systems)**

**This page intentionally left blank.**

## Table of Contents

|   |           |
|---|-----------|
| <b>1. General Safety Instructions</b> .....               | <b>1</b>  |
| 1.1 Symbols .....   | 1         |
| 1.2 Signal Words .....                                    | 2         |
| 1.3 Regulatory Compliance Statement.....                  | 2         |
| <b>2. Equipment Warning Labels</b> .....                  | <b>3</b>  |
| <b>3. Important Safety Instructions</b> .....             | <b>5</b>  |
| 3.1 Qualified Personnel Only.....                         | 6         |
| <b>4. Inspection/Storage/Disposal</b> .....               | <b>7</b>  |
| 4.1 Inspection .....                                      | 7         |
| 4.2 Unpacking.....  | 7         |
| 4.3 Storage .....   | 7         |
| 4.4 Disposal .....  | 7         |
| <b>5. Installation Precautions</b> .....                  | <b>8</b>  |
| 5.1 Conductor Routing and Grounding .....                 | 9         |
| <b>6. Installation</b> .....                              | <b>10</b> |
| 6.1 Module Arrangement .....                              | 10        |
| 6.2 System Installation.....                              | 11        |
| 6.3 Tower Installation with Cap .....                     | 12        |
| 6.4 Rackmount Installation - Bracket Mounting Holes ..... | 13        |
| 6.5 4-Post Rack Installation Instructions .....           | 13        |
| <b>7. Wiring the System</b> .....                         | <b>16</b> |
| 7.1 Layout - Power Module .....                           | 16        |
| 7.2 Layout - Battery Module (w/ Outlet Panel) .....       | 17        |
| 7.3 Layout - Transformer Module .....                     | 18        |
| 7.4 Power Module Cable Size and Tightening Torque.....    | 18        |
| <b>8. Operating Precautions</b> .....                     | <b>21</b> |
| <b>9. Control Panel</b> .....                             | <b>22</b> |
| 9.1 Control Panel Layout .....                            | 22        |
| 9.2 Light Emitting Diodes (LED) .....                     | 23        |
| 9.3 LCD Display - Open the Main Menu .....                | 23        |
| 9.4 LCD Display - Menu/Sub-Menu Navigation .....          | 24        |
| 9.5 LCD Display - Sub-Menu/Parameter Navigation .....     | 25        |
| <b>10. UPS Operation</b> .....                            | <b>26</b> |
| 10.1 Initial Startup.....                                 | 26        |
| 10.2 Startup (Normal) .....                               | 27        |
| 10.3 Bypass .....   | 27        |
| 10.4 Shutdown.....  | 28        |

|   |           |
|---|-----------|
| <b>11. System Description .....</b>                       | <b>29</b> |
| 11.1 Application and Use .....                            | 29        |
| 11.2 Power Backup .....                                   | 29        |
| 11.3 Power Conditioning .....                             | 29        |
| <b>12. Operating Modes .....</b>                          | <b>30</b> |
| 12.1 Static-Bypass (Stop operation) .....                 | 30        |
| 12.2 On-Line (Run operation) .....                        | 30        |
| 12.3 Battery Backup (On batteries) .....                  | 31        |
| 12.4 EPO (Emergency Power Off) Function .....             | 31        |
| 12.5 Cold Start (On Batteries) .....                      | 32        |
| 12.6 Frequency Conversion Mode (CVCF) .....               | 32        |
| 12.7 Battery Backup Time and Discharge Process .....      | 33        |
| 12.8 Battery Low Voltage Tolerances .....                 | 33        |
| 12.9 Battery Recharging .....                             | 34        |
| 12.10 Battery Test .....                                  | 35        |
| <b>13. Control Panel Menu Trees .....</b>                 | <b>36</b> |
| 13.1 Control Panel Navigation and Menu Access .....       | 36        |
| 13.2 Top Menu - Sub-Menu Tree .....                       | 37        |
| 13.3 Monitor Sub-Menu/Parameter Tree .....                | 38        |
| 13.4 Setting Sub-Menu/Parameter Tree .....                | 39        |
| 13.5 Records Sub-Menu/Parameter Tree .....                | 40        |
| <b>14. Operation .....</b>                                | <b>41</b> |
| 14.1 Cold Start .....                                     | 41        |
| 14.2 EPO and Remote Stop .....                            | 41        |
| <b>15. Communication Interfaces .....</b>                 | <b>43</b> |
| 15.1 Remote Contacts .....                                | 43        |
| 15.2 (Optional) RemotEye® Network Card .....              | 44        |
| 15.3 (Optional) Google Chrome™ Browser App .....          | 45        |
| 15.4 (Optional) EMD .....                                 | 46        |
| <b>16. UPS Protection System .....</b>                    | <b>47</b> |
| 16.1 UPS Protection Devices .....                         | 47        |
| 16.2 UPS Protection Devices Fault Response .....          | 47        |
| 16.3 System Fault Messages .....                          | 49        |
| 16.4 System Warning Messages .....                        | 50        |
| 16.5 System Mode Messages .....                           | 52        |
| 16.6 System Status Messages .....                         | 53        |
| <b>17. Preventive Maintenance/Parts Replacement .....</b> | <b>54</b> |
| 17.1 Preventive Maintenance .....                         | 54        |
| 17.2 LCD Display Cleaning .....                           | 54        |
| 17.3 Battery Replacement .....                            | 54        |

|   |            |
|---|------------|
| 17.4 Part Replacement.....  | 54         |
| <b>18. Shipping Weights/Dimensions.....</b>                           | <b>55</b>  |
| 18.1 Unit and Shipping Weights .....                                  | 55         |
| 18.2 Shipping Dimensions .....  | 55         |
| <b>Appendix A: Specifications.....</b>                                | <b>A-1</b> |
| A.1 T1000 POWER MODULE - 6kVA.....                                    | A-1        |
| A.2 T1000 POWER MODULE - 5.2kVA.....                                  | A-6        |
| A.3 T1000 BATTERY MODULE.....   | A-11       |
| A.4 T1000 TRANSFORMER MODULE.....                                     | A-12       |
| <b>Appendix B: T1000 Menu Table.....</b>                              | <b>B-1</b> |
| <b>Appendix C: T1000 Dimensional Drawings.....</b>                    | <b>C-1</b> |
| <b>Appendix D: T1000 Packing Lists and Kit Contents .....</b>         | <b>D-1</b> |
| Inter-Module Cabling Identification .....                             | D-1        |
| <b>Appendix E: T1000 Optional Installation Kit Instructions .....</b> | <b>E-1</b> |
| E.1 Optional 3-Module Tower Cap Kit - 93178 .....                     | E-1        |
| E.2 Optional Tower Caster Kit - 90508 .....                           | E-2        |
| E.3 Optional T1000 2-Post Rack Fixed Installation Kit - 92801.....    | E-5        |
| E.4 Optional T1000 4-Post Rack Slide Installation Kit - 92800.....    | E-8        |
| E.5 Optional T1000 2-Post Rack Slide Installation Kit - 90400.....    | E-11       |
| <b>Index .....</b>  | <b>I-1</b> |

**This page intentionally left blank.**

# 1. General Safety Instructions

DO NOT attempt to transport, install, operate, maintain or dispose of this equipment until you have read and understood all of the product safety information provided in this manual.

## 1.1 Symbols

The symbols listed below are used throughout this manual. When symbols are used in this manual they will include important safety information that must be carefully followed.



**Safety Alert Symbol** indicates that a potential personal injury hazard exists.



**Prohibited Symbol** indicates **DO NOT** take action.



**Mandatory Symbol** indicates that the following instruction is required.



**Ground Symbol** indicates the location of the equipment grounding conductor.



**Electrical – Voltage & Shock Hazard Symbol** indicates parts inside may cause electric shock.



**Explosion Hazard Symbol** indicates parts may explode.



**Heavy Lift Hazard Symbol** indicates object requires two- or more man lift, or lifting aid.

## 1.2 Signal Words

The signal words listed below are used throughout this manual. When the words DANGER, WARNING, CAUTION and NOTICE are used in this manual they will include important safety information that must be carefully followed.



The word **DANGER** in capital letters preceded by the safety alert symbol indicates that an **imminently hazardous** situation exists, and if not avoided **will result in loss of life or serious injury to personnel**.



The word **WARNING** in capital letters preceded by the safety alert symbol indicates that a **potentially hazardous** situation exists, and if not avoided **may result in loss of life or serious injury to personnel**.



The word **CAUTION** in capital letters preceded by the safety alert symbol indicates that a **potentially hazardous** situation exists, and if not avoided **may result in minor or moderate injury**.



The word **NOTICE** in capital letters without the safety alert symbol indicates a **potentially hazardous** situation exists, and if not avoided **may result in equipment and property damage**.

## 1.3 Regulatory Compliance Statement

### FCC Class A Notice

This equipment has been tested and found to comply with the limits for a Class A digital device, pursuant to Part 15 of the FCC Rules. These limits are designed to provide reasonable protection against harmful interference when the equipment is operated in a commercial environment. This equipment generates, uses, and can radiate radio frequency energy, and if it is not installed and used in accordance with the instruction manual, it may cause harmful interference to radio communications. Operation of this equipment in a residential area is likely to cause harmful interference, in which case the user will be required to correct the interference at his own expense.

This device complies with Part 15 of the FCC Rules. Operation is subject to the following two conditions:

1. This device may not cause harmful interference.
2. This device must accept any interference received, including interference that may cause undesired operation.

Notice: The FCC regulations provide that changes or modifications made to this device that are not approved by Toshiba International Corporation may void the authority granted to the user by the FCC to operate this equipment.

### EMC Directive Class A Note

This UPS is commercial in design and not intended for use at anytime in a Residential Environment.



## 2. Equipment Warning Labels

The following pages show examples of warning labels that may be attached to either the interior or exterior of the Power (UPS), Battery, or Transformer Modules. Do not remove or cover any of the labels. If the labels are damaged or if additional labels are required, contact your equipment representative for additional labels.

These labels in both English and French are placed to provide useful information or to indicate an imminently hazardous situation that may result in severe equipment/property damage, serious injury, or loss of life if instructions are not followed.

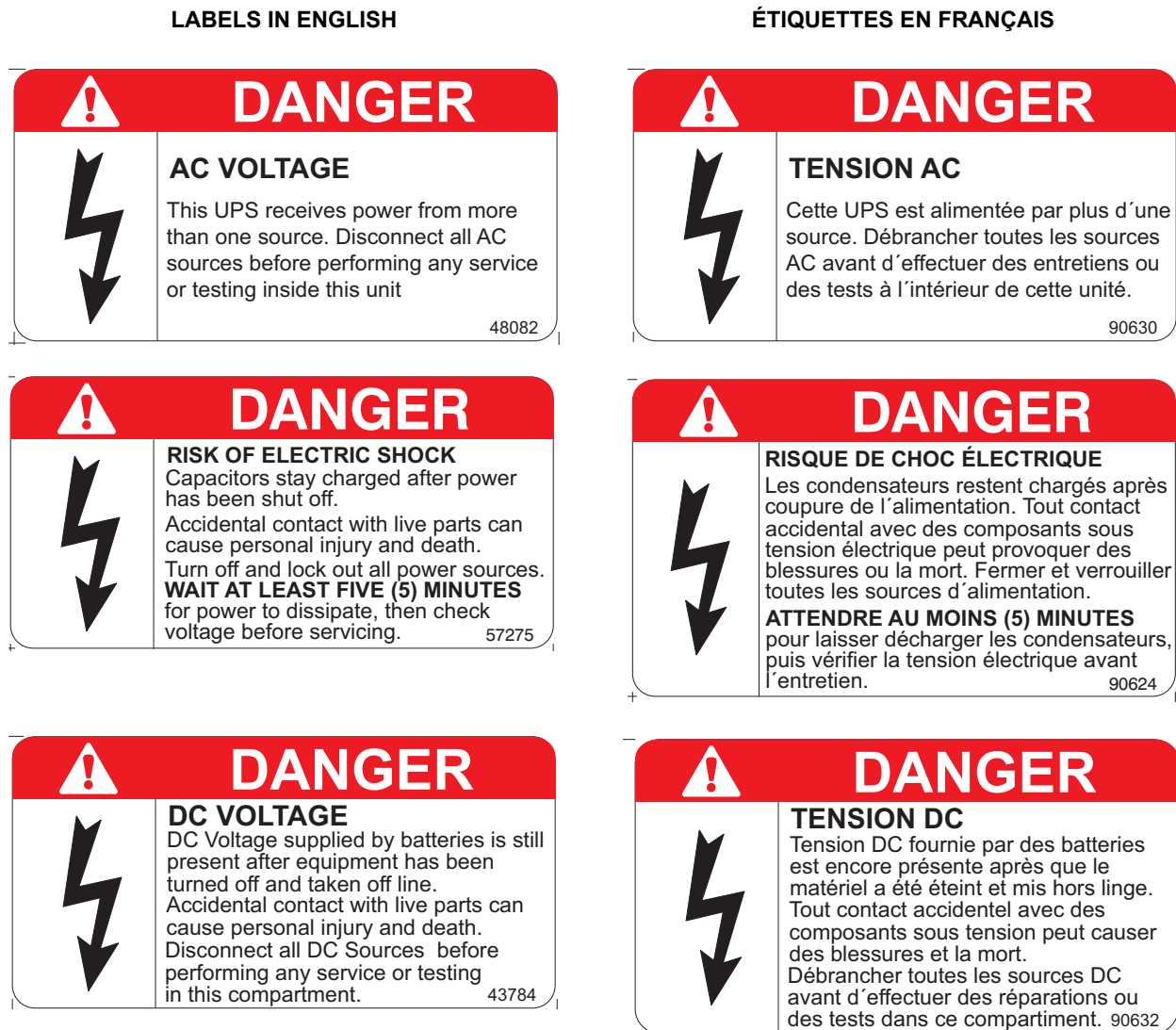




FIGURE 2-1: EQUIPMENT WARNING LABELS


LABELS IN ENGLISH


ÉTIQUETTES EN FRANÇAIS

|   |   |
|---|---|
| <b>⚠ DANGER</b>   |   |
|  | <p>Risk of electrical shock.<br/>Live terminals on batteries.<br/>Do not touch uninsulated battery terminal.</p> <p style="text-align: right;">PN 40759</p> |

|   |  |
|---|--|
| <b>⚠ DANGER</b>   |  |
|  | <p>Risque de choc électrique.<br/>Bornes de batteries sous tension.<br/>Ne pas toucher de borne de batterie non isolée.</p> <p style="text-align: right;">PN 90637</p> |

|   |  |
|---|--|
| <b>⚠ DANGER</b>   |  |
|  | <p><b>HAZARDOUS VOLTAGES</b><br/>Hazardous voltages are used in the operation of this equipment and could cause severe personal injury or loss of life. The following precautions should be observed to reduce the risk of injury or death.</p> <p>Only qualified technicians familiar with this equipment and the information supplied with it should be permitted to install and operate this equipment.</p> <p>Installation of electrical equipment must be done in accordance with National Electrical Code and any other state or local codes. Proper grounding and conductor sizing must be installed for safe operation.</p> <p>During operation, keep all covers in place and cabinet doors shut.</p> <p>When performing visual inspections and maintenance, if possible, be sure the UPS is turned off and the incoming AC feed is turned off and locked out.</p> <p><b>The UPS and Battery Cabinet will have hazardous voltages present even after the AC feed is turned off.</b></p> <p>If it is necessary to make measurements with the power on, do not touch any electrical connection points. Remove all jewelry from wrists and fingers. Make sure test equipment is in good, safe operating condition.</p> <p>While servicing, stand on some type of insulation, and be sure not to be grounded.</p> <p>Follow the safety instructions given in the equipment manual carefully and observe all danger, warning and caution notices.</p> <p style="text-align: right;">40308</p> |

|   |  |
|---|--|
| <b>⚠ DANGER</b>   |  |
|  | <p><b>TENSIONS DANGEREUSES</b><br/>Des tensions dangereuses sont utilisées dans l'opération de cet appareil et pourraient causer des blessures graves ou des pertes de vie. Les mesures de sécurité suivantes doivent être observées pour réduire le risque de blessure ou de mort.</p> <p>Seulement des techniciens qualifiés et familiarisés avec ce matériel, ainsi que la documentation fournie avec elle, devraient être autorisés à installer et à utiliser cet équipement.</p> <p>L'installation de l'équipement électrique doit être effectuée selon les normes électriques reconnues par les organismes nationaux ou provinciaux accrédités. Une bonne mise à la terre et un calibre de câble approprié doivent être installés pour un fonctionnement sécuritaire.</p> <p>Pendant le fonctionnement, maintenir tous les couvercles en place et les portes de l'armoire fermées.</p> <p>Lors des inspections visuelles et d'entretien, si possible, vérifier que l'UPS soit éteinte et que l'alimentation AC est éteinte et verrouillée.</p> <p><b>L'UPS et l'armoire de batterie auront des tensions dangereuses présentes même après avoir coupé l'alimentation AC.</b></p> <p>Si des mesures sur l'appareil sous tension doivent être effectuées, ne toucher à aucun point de connexion électrique. Retirer tous les bijoux des poignets et des doigts. S'assurer que l'équipement de test est en bon état de fonctionnement.</p> <p>Lors des opérations de maintenance, l'opérateur doit se tenir sur une surface isolée non reliée à la mise à la terre.</p> <p>Suivre attentivement les consignes de sécurité indiquées dans le manuel d'opération et respecter tous les avis de danger, les avertissements et les mises en garde.</p> <p style="text-align: right;">90638</p> |

|   |  |
|---|--|
| <b>⚠ CAUTION</b>  |  |
|  | <p>Risk of electrical shock.<br/>Battery circuit is not isolated from AC input, hazardous voltage may exist between battery terminals and ground.<br/>Test circuit before touching.</p> <p style="text-align: right;">PN 40760</p> |

|   |  |
|---|--|
| <b>⚠ ATTENTION</b>  |  |
|  | <p>Risque de choc électrique.<br/>Le circuit de la batterie n'est pas isolé de l'entrée AC, des tensions dangereuses peuvent exister entre les bornes de la batterie et la masse.<br/>Tester le circuit avant de toucher.</p> <p style="text-align: right;">PN 90636</p> |

FIGURE 2-1: (CONT.) EQUIPMENT WARNING LABELS

### 3. Important Safety Instructions

This manual contains important instructions that should be followed during the installation and maintenance of the UPS and its batteries.

The T1000 Series UPS is a modular single-phase double conversion system. Each of the rackmount modules is 3U (Three Standard Rack Units) high.

UPS systems are not equipped with an over-current protection device nor an output disconnect for the AC output. Circuit breakers should be provided by the user between the UPS Input and utility power, and the UPS output and the load input. This device should be rated as follows:

| <b>240/208 VAC RATING*</b>             | <b>5.2 kVA</b> | <b>6 kVA</b> |
|--|----------------|--------------|
| <b>Input Breaker<br/>240 V / 208 V</b> | 35             | 40 A         |
| <b>Output Breaker<br/>240V / 208V</b>  | 35             | 40 A         |

\* Ratings are for a 80% rated device.

The nominal battery voltages for these models is as follows:

| <b>UNIT</b>    | <b>BATTERY VOLTAGE</b>                                |
|----------------|---|
| <b>5.2 kVA</b> | 216 Vdc (Nominal)<br>(1 string of 18 x 12V batteries) |
| <b>6 kVA</b>   | 216 Vdc (Nominal)<br>(1 string of 18 x 12V batteries) |

Servicing the batteries should only be performed by a qualified factory authorized representative who is knowledgeable about batteries and the required precautions. Keep unauthorized personnel away from batteries. To arrange for battery replacement, contact Toshiba Customer Support Center.

1. Turn off, lockout, and tagout all equipment before connecting the power wiring to the equipment or when performing maintenance.
2. The maximum ambient operating temperature is 104 °F (40 °C). UPS will go to Bypass when it overheats.
3. Access panels should only be removed by authorized Toshiba field Service personnel.
4. UPS servicing should be performed by qualified Toshiba representatives only.
5. Battery servicing should be performed by qualified Toshiba representatives only.
6. Contact your Toshiba authorized service center for battery replacement.

### 3.1 Qualified Personnel Only

**Qualified personnel** are those who have the skills and knowledge relating to the construction, installation, operation, and maintenance of the electrical equipment and have received safety training on the hazards involved (Refer to the latest edition of NFPA 70E for additional safety requirements).

**Qualified personnel shall:**

1. Have read the entire operation manual.
2. Be trained and authorized to safely energize, de-energize, ground, lockout and tag circuits and equipment, and clear faults in accordance with established safety practices.
3. Be trained in the proper care and use of protective equipment such as safety shoes, rubber gloves, hard hats, safety glasses, face shields, flash clothing, etc., in accordance with established safety practices.
4. Be trained in rendering first aid.
5. Be knowledgeable about batteries and their required handling and maintenance precautions.

**For further information about workplace safety visit [www.osha.gov](http://www.osha.gov).**



Misuse of this equipment may result in human injury and equipment damage. In no event will Toshiba Corporation be responsible or liable for either indirect or consequential damage or injury that may result from the misuse of this equipment.



**DO NOT** dispose of the battery module in a fire. The batteries inside may explode.



**DO NOT** open or mutilate the batteries. Released electrolyte is harmful to the eyes and skin and could also be toxic.

To be performed by **Qualified Personnel Only**:

1. Verify that the UPS is off and that the power is disconnected from the power source.
2. Remove watches, rings or other metal objects.
3. Use tools with insulated handles to prevent inadvertent shorts.
4. Wear rubber safety gloves and boots.
5. **DO NOT** place tools or any metal parts on top of batteries.
6. Determine if the battery is inadvertently grounded. If inadvertently grounded, remove source of ground.

|                |  |
|----------------|--|
| <b>WARNING</b> |  |
|                | <p><b>Contact with any part of a grounded battery can result in electrical shock.</b></p> <p>The likelihood of shock will be reduced if such grounds are removed prior to installation or maintenance.</p> |

## 4. Inspection/Storage/Disposal

### 4.1 Inspection

Inspect for shipping damage upon receipt of the UPS. Use caution when removing the unit from the pallet. Refer to labels or documentation attached to packing material.

### 4.2 Unpacking

Check the unit for loose, broken, bent or otherwise damaged parts. If damage has occurred during shipping, keep all original crating and packing materials for return to the shipping agent. The warranty does not apply to damage incurred during shipping. Ensure that the rated capacity and the model number specified on the nameplate conform to the order specifications.

### 4.3 Storage

During periods of non-use, the following guidelines are recommended for storage.

#### Storage Preparation

1. Power up the UPS and allow it to operate with no load for 24 hours to fully charge the batteries.
2. Stop the unit (See Section 12.1 Bypass/Stop Operation).
3. Place the MCCB switch (Fig. 7-1 (1)) in the Off position.

#### Storing Conditions

- For best results, store the UPS in the original shipping container and place on a wood or metal pallet.
- Storage temperature: -4 – 104 °F (-20 – 40 °C).
- The optimum storage temperature is 70 °F (21 °C). A higher ambient temperature will require recharging more frequently during storage.

Avoid storage locations that:

- Are subject to extreme temperature changes or high humidity.
- Are subject to high levels of dust or metal particles.
- Are subject to excessive vibration.
- Have inclined floor surfaces.

#### Storage Maintenance

- If stored at an ambient temperature less than 68 °F (20 °C), recharge the batteries every 9 months.
- If stored at an ambient temperature of 68 – 86 °F (20 – 30 °C), recharge the batteries every 6 months.
- If stored at an ambient temperature of 86 – 104 °F (30 – 40 °C), recharge the batteries every 3 months.

### 4.4 Disposal

Contact your local or state environmental agency for details on disposal of electrical components and packaging in your particular area.

**It is illegal to dump lead-acid batteries in landfills or dispose of improperly.**

Please help our Earth by contacting the environmental protection agencies in your area, the battery manufacturer, or call Toshiba toll-free at (877) 867-8773 for more information about recycling.

## 5. Installation Precautions

### NOTICE

1. Observe the following environmental restrictions:
  - Install the unit in a well-ventilated location.
  - Install the unit where the ambient temperature is within the range specified in Appendix A - "Specifications".
  - DO NOT install the UPS in areas that are subject to high humidity.
  - DO NOT install the UPS in areas that allow exposure to direct sunlight.
  - DO NOT install the UPS in areas that allow exposure to high levels of airborne dust, metal particles, or flammable gases.
  - DO NOT install the UPS in areas near sources of electrical noise. Ensuring a proper earth ground will reduce the effects of electrical noise and will reduce the potential for electrical shock.
  - DO NOT install the UPS in areas that would allow fluids or any foreign object to get inside the UPS.
2. Install the unit in a stable, level and upright position that is free of excessive vibration.
3. Follow the instructions on the unpacking label affixed to the exterior of the UPS.
4. Tower Unit with Caster Kit Option Only: Once the installation is complete, screw down the UPS leveling feet located next to the front and back casters, until the unit is no longer resting on the casters.
5. The UPS generates and can radiate radio-frequency energy during operation. Although RFI noise filters are installed inside of the unit, there is no guarantee that the UPS will not influence some sensitive devices that are operating near by. If such interference is experienced, the UPS should be installed farther away from the affected equipment and/or powered from a different source than that of the affected equipment.
6. It is the responsibility of the installer of this equipment to provide a suitable disconnect for the Control Panel supplying power to this equipment.

This disconnect must:

Be suitable for the Voltage and Full Load Ampere Rating of all downstream equipment supplied by the Panel;

The supply disconnecting device shall be one of the following types:

- Switch-disconnect, with or without fuses, in accordance with IEC 60947-3, utilization category AC-23B or DC-23B
- As above, except one that has an auxiliary contact that in all cases causes switching devices to break the load circuit before the opening of the main contacts of the disconnect.
- A circuit breaker suitable as an isolation device per IEC 60947-2
- Any other switching device in accordance with an IEC product standard that also meets the isolation requirements of IEC 60947-1 and is appropriate for on-load switching of motors or other inductive loads;

Be approved for use as a disconnect for the country in which this equipment is installed.

Be provided with a Lock Out Tag Out capability in the Off (Down) position.

7. Allow 5 minutes after power is removed for internal capacitors to fully discharge before attempting to service the unit.
8. The user should provide output over-current protection for hardwired UPS systems. See “Appendix A: T1000 Specifications” on page A-1A-2 for the device rating.
9. After ensuring that all power sources are turned off and isolated in accordance with established lockout/tagout procedures, connect the power source wiring of the correct voltage to the input terminals of the UPS.
10. Hardwire Only: Connect the output terminals of the UPS to the load in line with local wiring regulations. Size the branch circuit conductors in accordance with NEC Table 310.16.

### 5.1 Conductor Routing and Grounding

1. Use separate metal conduits for routing the input power, output power, and control circuits.
2. Follow the wire size and tightening torque specifications listed on Table 7-4.
3. Always ground the unit to reduce the potential for electrical shock and to help reduce electrical noise.
4. A separate ground cable should be run inside the conduit with the input power, output power, and control circuits.

|  |  |
|--|--|
|  <b>WARNING</b> |  |
|               | <b>METAL OF CONDUIT IS NOT AN ACCEPTABLE GROUND.</b> |



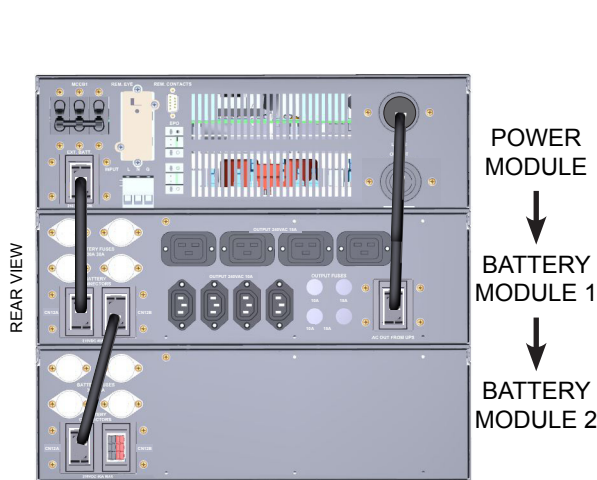
## 6. Installation

### 6.1 Module Arrangement

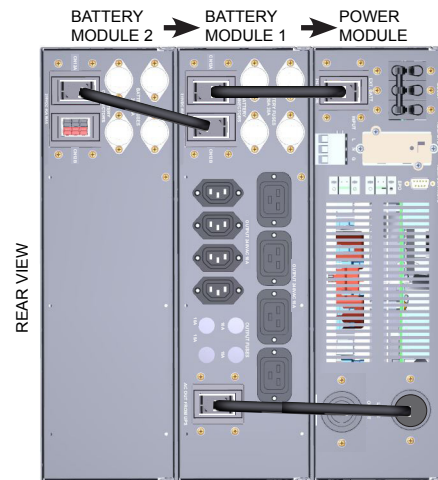
The T1000 Series UPS consists of a Power (UPS) module, optional Battery module(s), and optional Transformer module for output other than 240/208 V. These modules can be purchased in either a rack-mount or tower configuration.

Module arrangement is determined by the length of the factory-supplied inter-module cables. The Modules should be arranged in the following order as viewed from the front: top-to-bottom for Rackmount (Fig. 6-1, Fig. 6-2); left-to-right for Tower (Fig. 6-3, Fig. 6-4).

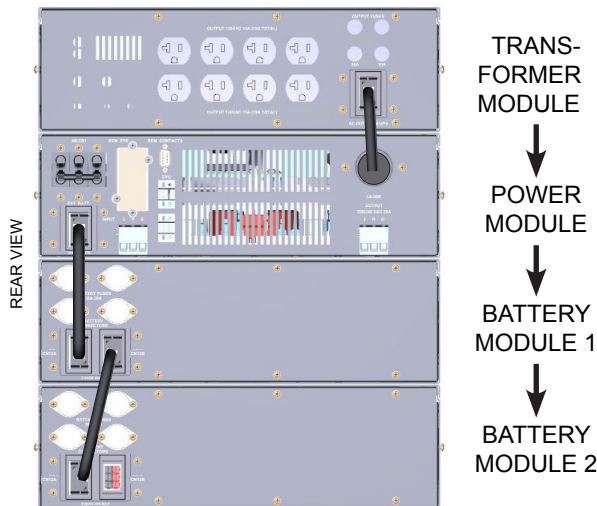
*NOTE: If a Transformer module is used, then the battery module(s) may, or may not, have an output panel.*



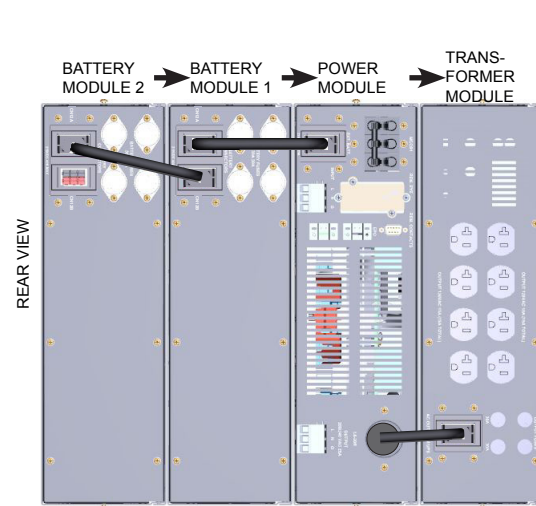
**FIGURE 6-1: RACKMOUNT 240V<sub>OUT</sub> SYSTEM WITH C-13/C-19 PANEL**



**FIGURE 6-3: TOWER 240V<sub>OUT</sub> SYSTEM WITH C-13/C-19 PANEL**



**FIGURE 6-2: RACKMOUNT 120V<sub>OUT</sub> SYSTEM WITH TRANSFORMER MODULE**



**FIGURE 6-4: TOWER 120V<sub>OUT</sub> SYSTEM WITH TRANSFORMER MODULE**



## 6.2 System Installation

The T1000 Series Power (UPS) module, optional Battery module(s), and optional Transformer module can be purchased in either a rackmount or tower configuration. All three modules are a standard 3U (3 Rack Units) tall, and fit a standard 19 in. rack.

### TOWER CONFIGURATION:

In the tower configuration, the orientation of the modules are rotated 90 degrees counter-clockwise, placing the ventilation openings on the bottom. A slip-on Tower Cap is used to provide physical stability for systems of two or more tower modules, including tower systems with optional casters. (Figure 6-5)

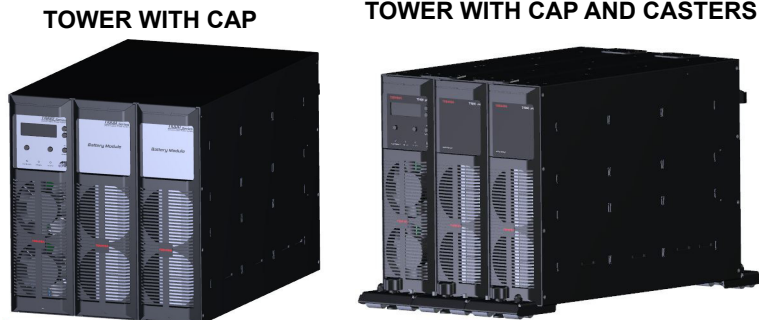
- **OPTIONAL: TOWER CAPS**  
Each 2-Module tower system comes with a Tower Cap that helps maintain physical tower stability. Optional 3-Module Tower Caps are available for larger systems.
- **OPTIONAL: CASTERS**  
An optional caster kit may also be purchased with each module to facilitate relocating the system before and after installation.

### RACKMOUNT CONFIGURATION:

Each rackmount configuration module ships with a **4-Post Rack Fixed Mounting Kit**, P/N 92802, for mounting the module in a standard 19 inch rack.

Other rack mounting kit configurations are available: (Figure 6-6)

- **OPTIONAL: 2-POST RACK FIXED MOUNTING KIT**  
Hardware for mounting system modules in a standard 19 inch 2-post rack. See Appendix E.
- **OPTIONAL: 4-POST RACK SLIDE MOUNTING KIT**  
Hardware for mounting system modules in a standard 19 inch 4-post rack with fully extending slide rails. See Appendix E.
- **OPTIONAL: 2-POST RACK SLIDE MOUNTING KIT**  
Hardware for mounting system modules in a standard 19 inch 2-post rack with fully extending slide rails. See Appendix E.



**FIGURE 6-5: TOWER INSTALLATION OPTIONS**



**FIGURE 6-6: RACK INSTALLATION OPTIONS**

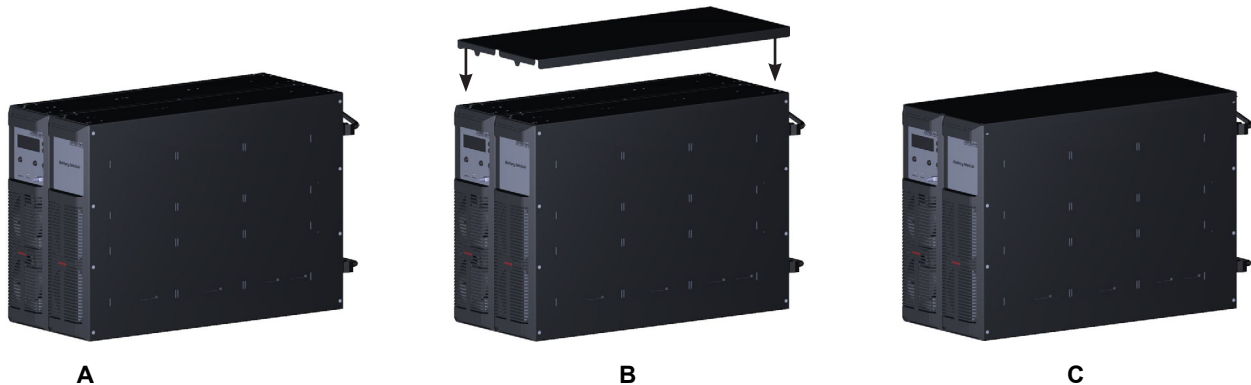
### 6.3 Tower Installation with Cap

The Tower configuration modules are arranged side by side, and secured by a press-fit cap over the assembly. If the optional Caster Kit is available, see Appendix E2 for installation.

1. Unpack the T1000 modules and set them in the desired location with the faceplates at the top as shown below.
2. Facing the front of the modules, arrange them left to right in the following order (See Fig. 6-1 - 6-4):
  - Transformer Module (if available)
  - Power Module
  - Battery Module with output panel (if available)
  - Second Battery Module without output panel (if available)

*NOTE: There is a Tower Cap for 2-, and 3-module tower systems. Fig. 6-7 shows Tower Cap installation for a 2-module system.*

3. Press the T1000 Tower Cap over the tower modules (Fig. 6-7).
4. The T1000 tower is ready for interconnecting cable installation.
5. Go to Section 7 for cabling instructions.



**FIGURE. 6-7: INSTALL CAP ON TWO MODULE TOWER SYSTEM**

### 6.4 Rackmount Installation - Bracket Mounting Holes

The Power Module, Battery Module, and Transformer Module all come with the mounting bracket holes located symmetrically on each side. See Fig. 6-8 for the hole locations. Table 6-1 lists the mounting hardware for the bracket holes.

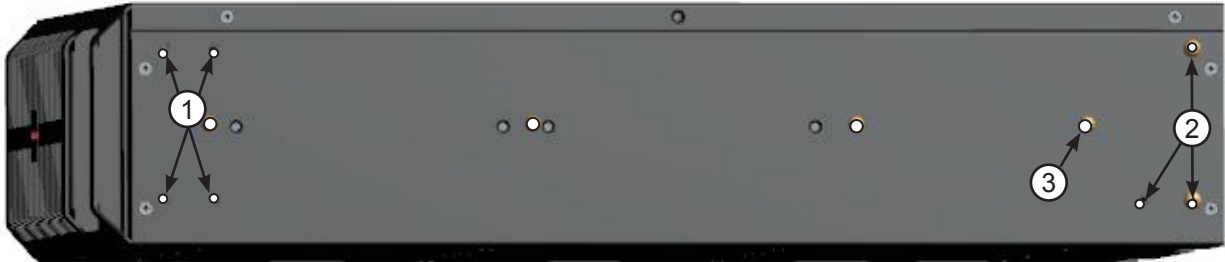


FIGURE. 6-8: RACKMOUNT BRACKET MOUNTING HOLES

TABLE 6-1 RACKMOUNT BRACKET MOUNTING HOLES AND HARDWARE

| No. | Accepts (per side)        | Used for  |
|-----|---------------------------|---|
| 1   | 4 x Phillips 8-32 x 1/4"  | Mount for front bracket 68844 used for 4-Post fixed mounting                      |
| 2   | 3 x Phillips 8-32 x 1/4"  | Mount for rear bracket 92746 used for 4-Post Fixed Mounting Brackets (Kit 92802), |
| 3   | 1 x Phillips 10-32 x 1/2" | Mount for rear bracket 92746 used for 4-Post Fixed Mounting Brackets (Kit 92802), |

**CAUTION**

**Heavy object**

**Can cause muscle strain or back injury.**

Use lifting aids and proper lifting techniques when handling or installing T1000 Modules.

### 6.5 4-Post Rack Installation Instructions

Use the 4-Post Fixed Rackmount Kit 92802 (1 kit per module) to mount the T1000 module in a 19-inch, 4-Post rack as follows.

**Contents - Fixed 4-Post Rack Installation Kit (92802)**

- 1 ea.: T1000 Fixed 4-Post Rack Installation Instructions - 94036
- 2 ea.: 68844 - Ear Chassis Mounting
- 2 ea.: 92746 - Bracket, Rear Fixed Mounting, 4-Post, Black

**(Hardware Kit 93863)**

- 12 ea.: Cage Nut, 1/4"-20
- 12 ea.: Hex bolt, Sems, 1/4"-20 x 5/8"
- 12 ea.: Screw, PHP (Pan Head Phillips) 10-32 x 1/2" St Box
- 4 ea.: Screw, PHP 8-32 x 1/4" St Zi

**Prepare the 4-Post Rack**

1. Clip the cage nuts (PC76315P501 Cage Nut, 1/4"-20) from the 93863 kit over the rack rail mounting

holes at the desired level. Clip 2 cage nuts spaced vertically 4 in. apart on each Post.

2. If more than one module is being installed for the T1000 system, install the next pair of cage nuts 3 Rack Units (5 1/4") above the first set of cage nuts for the next module.
3. Repeat Steps 1-2 for each T1000 module to be installed. Continue until cage nuts for all the modules in the system have been clipped on the 4-Post rack.

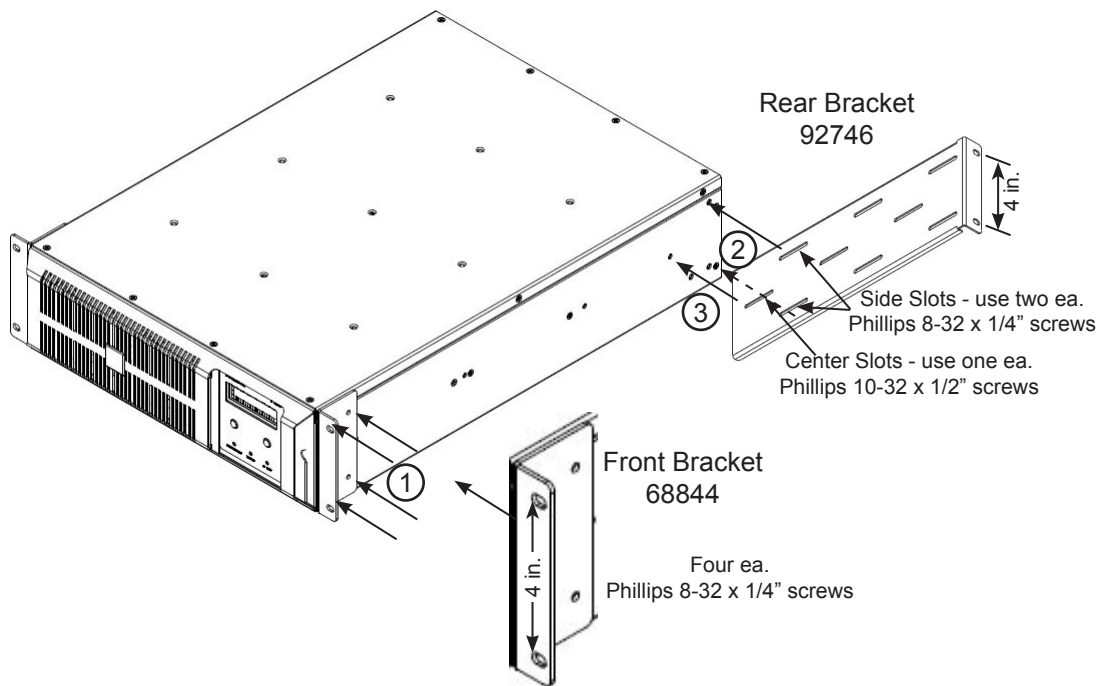
**Prepare the Module(s)**

4. Attach the front and rear bracket to the left and right sides of the T1000 module as shown in Fig. 6-9. Use the mounting hardware from Kit 93863 to secure the brackets to the mounting holes indicated in Fig. 6-8 and Table 6-1.
5. Secure the Front Brackets, P/N 68844, to the left and right front side of the module at Fig. 6-9 (1) using four Phillips 8-32 x 1/4" screws.
6. Secure the Rear Brackets, P/N 92746, to the left and right rear side of the module at Fig. 6-9 (2) using 1 Phillips 8-32 x 1/4" screw each in the top and bottom slot, and use a Phillips 10-32 x 1/2" in the center slot (Fig. 6-9 (3)).

**Install the Module(s) in the 4-Post Rack**

**CAUTION: Battery Modules weight 150 lb. (68 kg). Use lifting aids and proper lifting techniques.**

7. Follow the vertical arrangement of T1000 modules as discussed in Section 6.1. Mount the lowest module in the 4-Post rack to the bottom pair of cage nuts on each Post using the 1/4"-20 x 5/8" hex bolts, (P/N 33798).
8. Repeat Step 7 for the remaining modules, working from bottom to top. (Fig. 6-10)
9. Go to Section 7 for cabling instructions.



**FIGURE 6-9: FIXED MOUNTING BRACKETS - 4-POST RACK**



**FIGURE. 6-10: 4-POST RACK - FIXED**

## 7. Wiring the System

### 7.1 Layout - Power Module

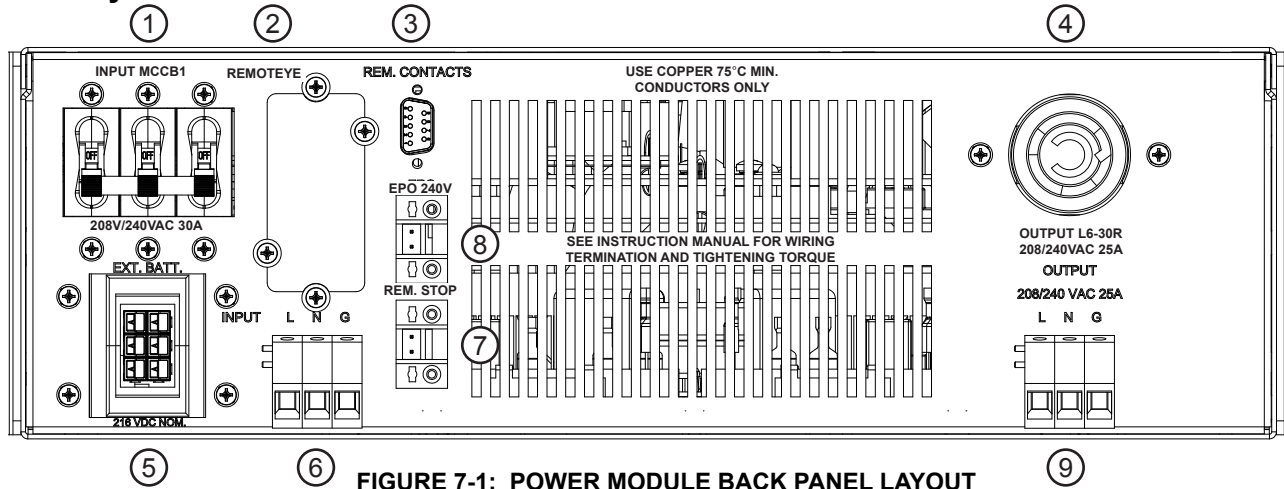


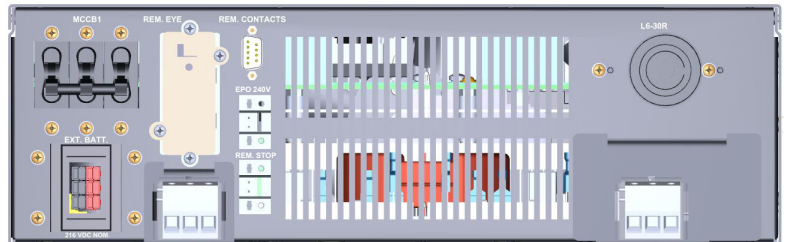
FIGURE 7-1: POWER MODULE BACK PANEL LAYOUT

TABLE 7-1: POWER MODULE BACK PANEL LAYOUT

| No. | Label                           | Function   |
|-----|---------------------------------|--|
| 1   | INPUT MCCB1<br>208V/240VDC      | Main On/Off circuit breaker.   |
| 2   | REMOTEYE                        | Cover plate for RemotEye® circuit card slot.                                       |
| 3   | REM. CONTACTS                   | Dry contacts DB9 connector.  |
| 4   | OUTPUT L6-30R<br>208/240VAC 25A | Output receptacle for L6-30P cord (alternate output for 208/240 only)              |
| 5   | EXT. BATTERY                    | External Battery Module Anderson receptacle.                                       |
| 6   | INPUT L N G                     | Hardwire input terminals <u>L</u> ine, <u>N</u> eutral, and <u>G</u> round. (TB1)  |
| 7   | REM. STOP                       | Remote Stop Contacts. (TB4) (10 VDC)   |
| 8   | EPO 240V                        | Remote Emergency Power Off (EPO) Contacts. (TB3) (240/208 VAC)                     |
| 9   | OUTPUT L N G                    | Hardwire output terminals <u>L</u> ine, <u>N</u> eutral, and <u>G</u> round. (TB2) |

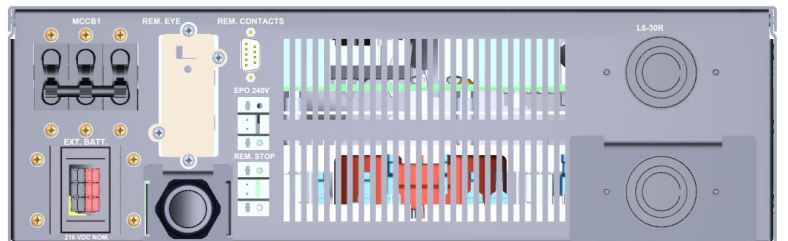
**FIGURE 7-2: 6KVA POWER MODULE - HARDWIRED CONFIGURATION (P/N T1P0A6000GXG, T1P0A6000GXGR3)**

3-Post Input Terminal Block, and one each 3-Post Output Terminal Block and NEMA L6-30R outlet.



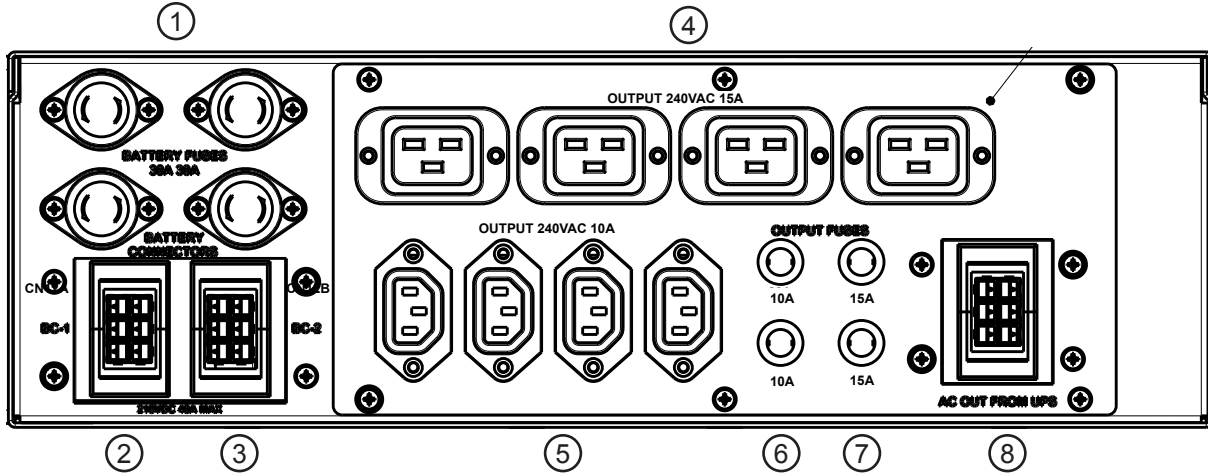
**FIGURE 7-3: 6KVA & 5.2KVA POWER MODULE WITH LINECORD (-L1) OPTION (P/N T1P0A6000GXGL1, T1P0A6000GXGR3L1) (P/N T1P0A5200GXGR3L1)**

6kVA - Input Power Cord #10-3SO 6-50P  
5.2kVA - Input Power Cord #10-3SO L6-30P  
and two each NEMA L6-30R outlets.



**7.2 Layout - Battery Module (w/ Outlet Panel)**

Compatible with both the 5.2kVA and 6kVA Power Modules.

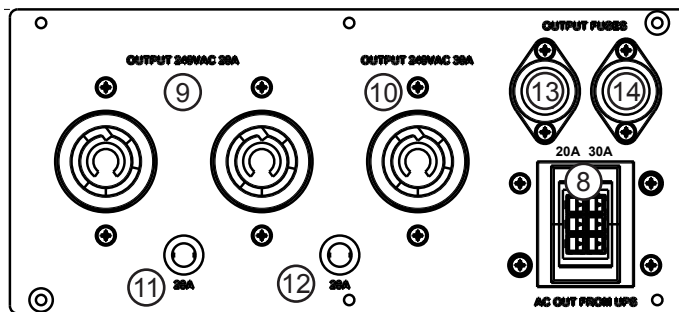


**FIGURE 7-4: BATTERY MODULE WITH P1 OUTLET PANEL - LAYOUT**

**TABLE 7-2: BATTERY MODULE - BACK PANEL LAYOUT**

| No.  | Label             | Function   |
|--|-------------------|--|
| 1  | BATTERY FUSES     | Battery Fuses, 4 ea. (500V, 30A)   |
| 2  | CN12A             | Battery cable Anderson Receptacle (w/ Int. Thermistor) - Connect to Power Module "Ext. Battery". |
| 3  | CN12B             | Battery cable Anderson Receptacle - Connect to second Battery Module CN12A or CN12B              |
| P1 OPTIONAL OUTLET PANEL 91425: C-13 & C-19          |                   |  |
| 4  | OUTPUT 240VAC 15A | Outlet Receptacles: 4 ea. IEC C-19, (250V, 20A N. America., 15A INT.).                           |
| 5  | OUTPUT 240VAC 10A | Outlet Receptacles: 4 ea. IEC C-13, (250V, 10A N.America., 10A INT.).                            |
| 6  | OUTLET FUSES 15A  | Outlet Fuses for IEC C-19 receptacles. (250V, 15A)   |
| 7  | OUTLET FUSES 10A  | Outlet Fuses for IEC C-13 receptacles. (500V, 10A)   |
| 8  | AC OUT FROM UPS   | Anderson receptacle for UPS output cable.  |
| P2 OPTIONAL OUTLET PANEL 91427: NEMA L6-20R & L6-30R |                   |  |
| 8  | AC OUT FROM UPS   | Anderson receptacle for UPS output cable.  |
| 9  | OUTPUT 240VAC 20A | Outlet Receptacles: 2 ea. NEMA L6-20R, (250V, 20A).  |
| 10   | OUTPUT 240VAC 30A | Outlet Receptacle: 1 ea. NEMA L6-30R, (250V, 30A).   |
| 11   | OUTLET FUSE 20A   | Outlet Fuse for NEMA L6-20R receptacle (250V, 20A).  |
| 12   | OUTLET FUSE 20A   | Outlet Fuse for NEMA L6-20R receptacles (250V, 20A).   |
| 13   | OUTLET FUSE 30A   | Outlet Fuses for NEMA L6-30R receptacle (500/600V, 30A).   |
| 14   | OUTLET FUSE 30A   | Outlet Fuses for NEMA L6-30R receptacles (500/600V, 30A).  |

**FIGURE 7-4: BATTERY MODULE OUTPUT PANEL P2 - LAYOUT**





### 7.3 Layout - Transformer Module

Compatible with both the 5.2kVA and 6kVA Power Modules.

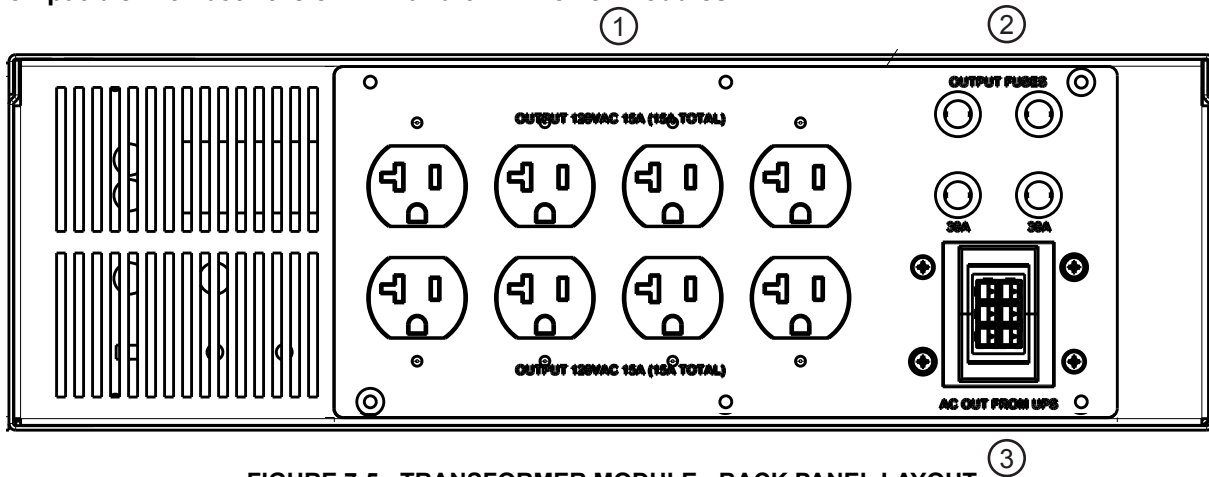


FIGURE 7-5: TRANSFORMER MODULE - BACK PANEL LAYOUT

TABLE 7-3: TRANSFORMER MODULE BATTERY MODULE - BACK PANEL LAYOUT

| No. | Label             | Function   |
|-----|-------------------|--|
| 1   | OUTPUT 120VAC 20A | Output Receptacle Panel: 4 duplex NEMA 5-20R (250V, 20A)   |
| 2   | OUTPUT FUSES      | Fuses, 4 ea. ,(250V, 20A)<br>(4 Line fuses, one for each pair NEMA 5-20R. Total current limit for each pair receptacles is 20A.<br>Total output from all receptacles must not exceed 50 A) |
| 3   | AC OUT FROM UPS   | Anderson receptacle for UPS output cable.  |

### 7.4 Power Module Cable Size and Tightening Torque

The Battery Modules and Transformer modules come with their own inter-module cabling included. See Fig. 7.5.

Only the Power Module Input terminals need to have wiring installed.

The Power Module Output terminal wired using either:

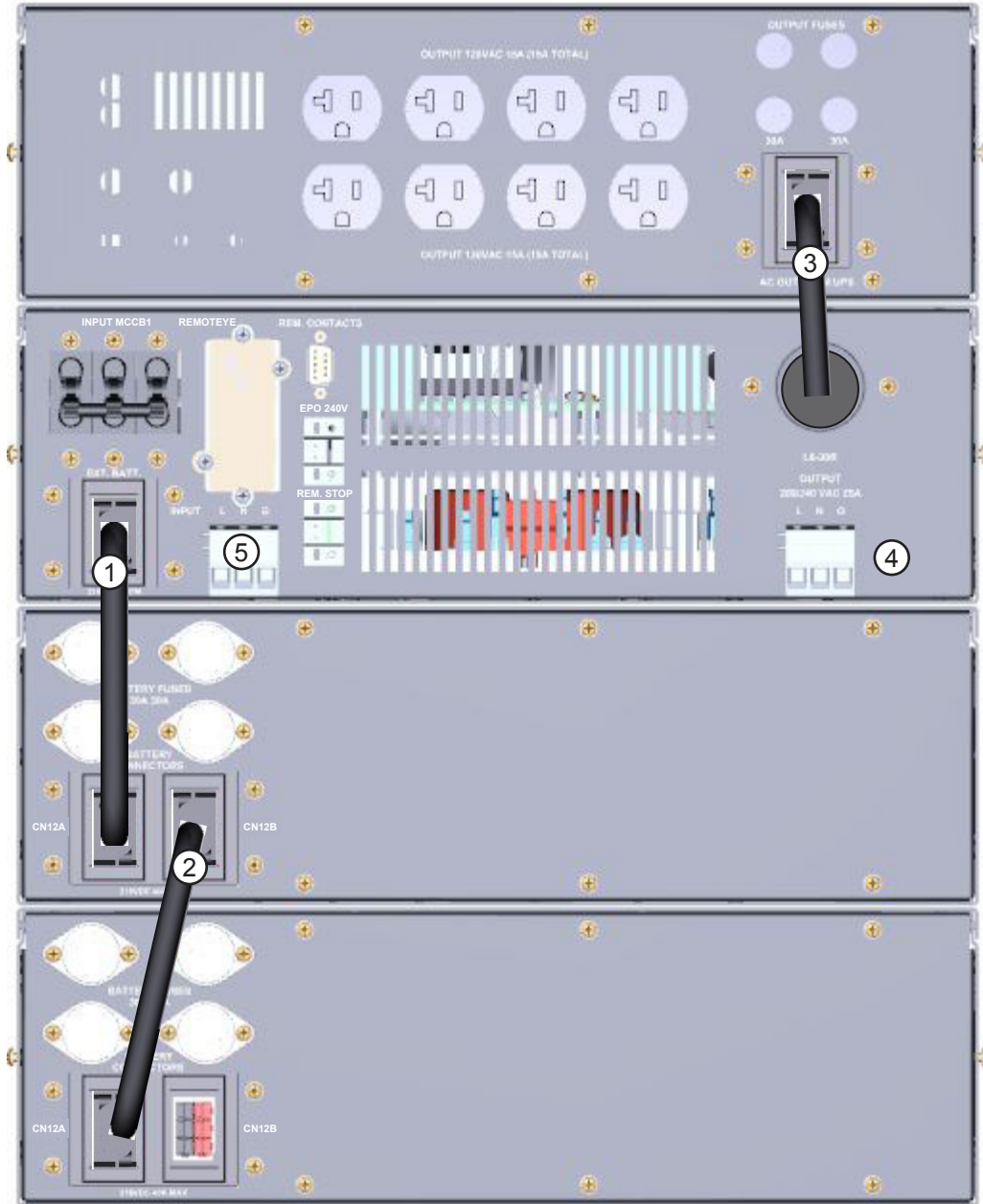
- Factory-supplied inter-module cables
- Customer-supplied hardwire cables

Use the following table to select the recommended wire size and terminal lug tightening torque for I/O wire connections.

TABLE 7-4: POWER MODULE CABLE SIZING AND TERMINAL TORQUE SPECIFICATIONS- HARDWIRE  
(USE COPPER 75°C MIN. CONDUCTORS ONLY)

| Terminal                | Terminal Number | Terminal Capacity (AWG) | Recommended Wire | Stripping Length in (mm) | Tightening Torque lb.-in. (N•m) |
|-------------------------|-----------------|-------------------------|------------------|--------------------------|---------------------------------|
|                         |                 |                         | 6 kVA            |                          |                                 |
| AC Input Line, Neutral  | L, N            | 24 - 6                  | 10 - 8           | 0.43 in (11 mm)          | 11 - 21 (1.2 - 2.4)             |
| AC Input Ground         | G               | 24 - 6                  | 10 - 8           |                          | 11 - 21 (1.2 - 2.4)             |
| AC Output Line, Neutral | L, N            | 24 - 6                  | 10 - 8           | 0.43 in (11 mm)          | 11 - 21 (1.2 - 2.4)             |
| AC Output Ground        | G               | 24 - 6                  | 10 - 8           |                          | 11 - 21 (1.2 - 2.4)             |
| EPO Switch              | (Plug)          | 30 - 12                 | 18 - 16          | 0.27 in (7 mm)           | 3.5 - 4.4 (0.4 - 0.5)           |
| Remote Switch           | (Plug)          | 30 - 12                 | 18 - 16          |                          | 3.5 - 4.4 (0.4 - 0.5)           |

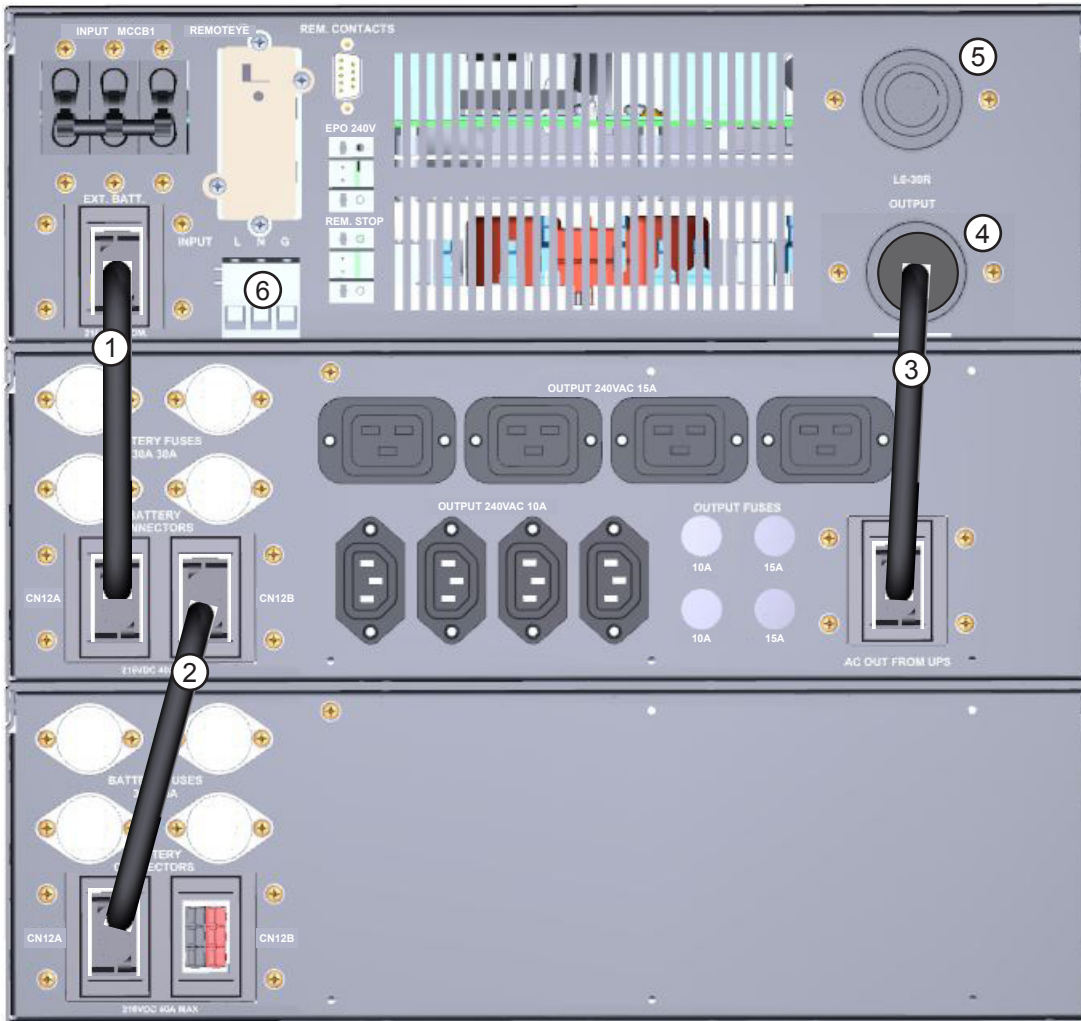




**FIGURE 7-5: FACTORY SUPPLIED CABLING GUIDE - W/ 120V XFMR MODULE**

**TABLE 7-5: 120V SYSTEM CABLING SPECIFICATIONS**

| No. | Item  | Function  |
|-----|---|---|
| 1   | 92855 Battery Connector Cable                           | Factory Supplied - Connects Power Module EXT BATT to Batt Module BC1 CN12A to using keyed Anderson Connectors.                              |
| 2   | 92855 Battery Connector Cable                           | Factory Supplied - Connects Batt Module BC1 CN12B to either Batt Module BC2 CN12A or Batt Module BC2 CN12B using keyed Anderson Connectors. |
| 3   | 92858 (240V) and 92883 (208V) Power Module L6-30 Output | Both Factory Supplied - L6-30P twistlock to Xfmr Module keyed Anderson Connector.   |
| 4   | TB2 240V Hardwire Output                                | User Supplied (two wire plus ground)  |
| 5   | TB1 240V Hardwire Input                                 | User Supplied (two wire plus ground)  |



**FIGURE 7-6: FACTORY SUPPLIED CABLING GUIDE - W/ BC OUTPUT PANEL**

**TABLE 7-6: 240V SYSTEM CABLING SPECIFICATIONS**

| No. | Item   | Function  |
|-----|--|---|
| 1   | 92855 DC Connector Cable: Batt Module 1 to Pwr Module                                  | Factory Supplied - Connects Power Module EXT BATT to Batt Module BC1 CN12A to using keyed Anderson Connectors.                              |
| 2   | 92855 DC Connector Cable: Batt Module 1 to Batt Module 2                               | Factory Supplied - Connects Batt Module BC1 CN12B to either Batt Module BC2 CN12A or Batt Module BC2 CN12B using keyed Anderson Connectors. |
| 3   | 92858 AC Connector Cable: Power Module L6-30R Output to Batt Module Output Panel P1/P2 | Both Factory Supplied - L6-30P twistlock to Xfmr Module keyed Anderson Connector.   |
| 4   | Output L6-30R Receptacle Panel   | User Selectable - Can be either a L6-30 Receptacle or a 3-Post, 3 wire terminal 240V output.  |
| 5   | Output L6-30R Receptacle   | Accommodates L6-30P twistlock cord (alternate output for 208/240 only).   |
| 6   | TB1 240V Hardwire Input  | User Supplied (two wire plus ground)  |

## 8. Operating Precautions

1. The UPS should not be powered up until the entire operation manual has been read.
2. The voltage of the input power source must operate within the On-line Tolerance range of +10% to -15% to avoid transferring to Bypass. The input frequency must be within the rated input frequency range. Voltages and frequencies outside of the permissible range may activate the internal protection devices.
3. The Bypass can be programmed to accept one of three voltage tolerances without dropping the load.

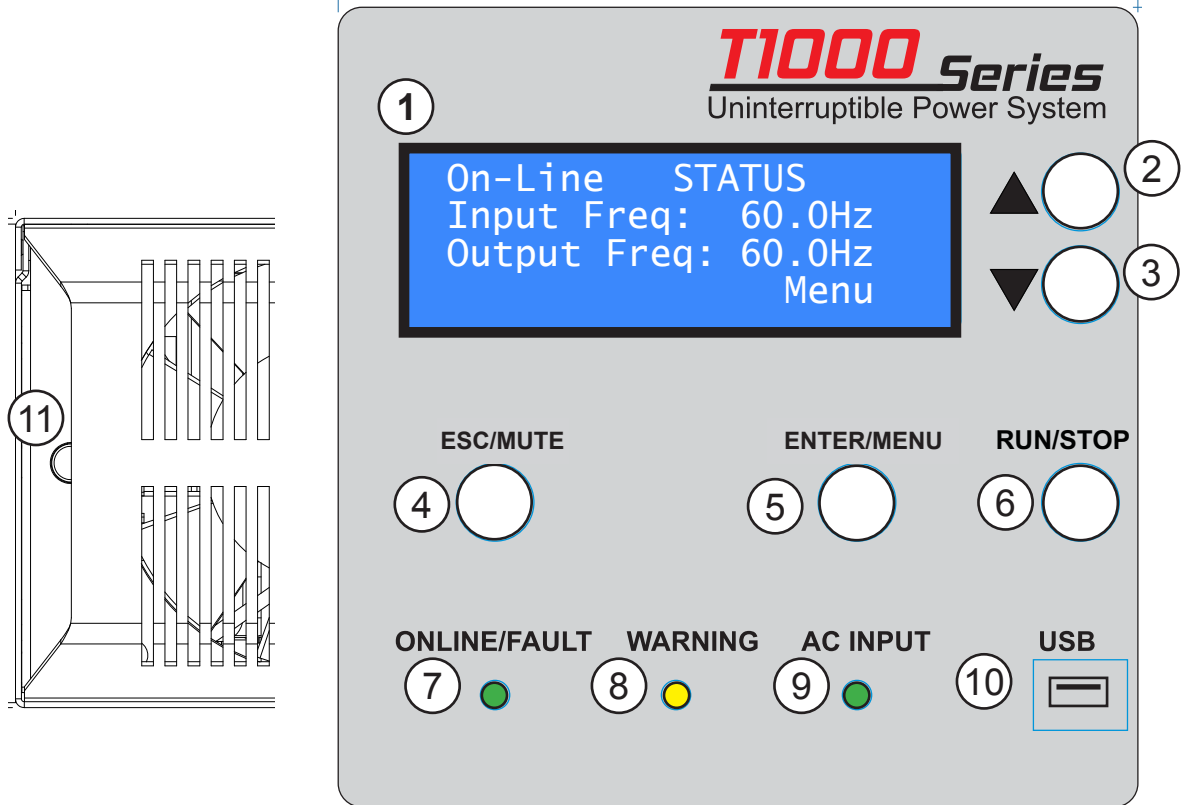
| Bypass Input Voltage Tolerance Selection |
|--|
| +10% to -10%                             |
| +10% to -15%                             |
| +15% to -20%                             |

4. The UPS should not be used with a load that has a rated input voltage that is smaller than the output voltage of the UPS.
5. DO NOT use the UPS to provide power to motors that require high starting current or with motors that require a long starting time, such as vacuum cleaners and machine tools (oversizing the UPS for locked rotor current would be required).
6. DO NOT insert metal objects or combustible materials in the ventilation slots of the UPS.
7. DO NOT place, hang, or paste any objects on the exterior surfaces of the UPS.
8. The capacitors of the UPS maintain a residual charge for a while after turning the UPS off.
9. DO NOT attempt to disassemble, modify, or repair the UPS. Repairs and servicing should only be performed by Toshiba Field Service personnel.
10. DO NOT remove any covers of the UPS when the power is on.
11. Turn the power on only after installing ALL of the covers.
12. If the UPS should emit smoke, produce an unusual odor, or make sound, turn the power off immediately.
13. Changing/replacing the UPS Batteries should only be performed by Toshiba field service personnel.
14. Warning signs should be placed on or near the load as a notification that the load is being powered by the UPS.
15. Additional warnings and notifications shall be posted at the equipment installation location as deemed required by **Qualified Personnel**.

## 9. Control Panel

### 9.1 Control Panel Layout

Fig. 9-1 shows the LCD display and control layout for the T1000 UPS.



**FIGURE 9-1: FRONT PANEL LAYOUT**

**TABLE 9-1: FRONT PANEL LAYOUT**

| Item # | Description   | Item # | Description  |
|--------|---|--------|--|
| 1      | Four-line by 20 character LCD Display   | 7      | ONLINE/FAULT LED - Indicates UPS is either Online (Green) or experiencing a Fault (Red)  |
| 2      | ▲ UP Push button - Scroll up one entry of display stack (Entries may be one or more lines long)   | 8      | WARNING LED - Lights (Amber) when a Warning occurs   |
| 3      | ▼ DOWN Push button - Scroll down one line of display stack.   | 9      | AC INPUT LED - Lights (Green) when power is applied to the UPS   |
| 4      | ESC/MUTE Push button - Press to return to previous screen or cancel configuration mode. (In Main screen, re-enables autoscroll)<br>MUTE - Press and hold ~5 sec. to Mute/Unmute the alarm | 10     | Mini-USB port - Allows direct PC monitoring of UPS performance   |
| 5      | ENTER/MENU Push button - Press to Enter the highlighted category. In Settings page use to enter configuration mode or confirm changes.  | 11     | Cold Start Switch - Starts UPS in backup mode when utility power is not available.<br><b>NOTICE</b> If Utility Power is not restored before the batteries are fully discharged, the UPS will shut down. (See Section 12.5) |
| 6      | RUN/STOP Push button - Toggle Inverter between On-Line (RUN) and Bypass (STOP) mode   |        |  |

## 9.2 Light Emitting Diodes (LED)

The following table describes the front panel LED behaviors and the associated meaning.

**TABLE 9-2: FRONT PANEL LED INDICATORS**

| LED              | Behavior         | Significance/Meaning   |
|------------------|------------------|--|
| ONLINE/<br>FAULT | Green - ON       | UPS is in On-Line, Backup, or Battery Test mode.                                 |
|                  | Green - OFF      | UPS in Bypass mode.  |
|                  | Green - ON       | UPS Backup mode ON. (Battery Discharging)  |
|                  | Red - ON         | One or more faults occurred. See <i>Records: Faults</i> for details.             |
|                  | Red - Flashing   | Charger overvoltage occurred.  |
|                  | Red - OFF        | No fault occurred.   |
| WARNING          | Amber - ON       | Service Call needed, <b>Less than 6 mo. of Battery Life or Battery Life End.</b> |
|                  | Amber - Flashing | One or more Warnings occurred. See <i>Records: Warnings</i> for details.         |
|                  | Amber - OFF      | No Warning (Normal, UPS in operation).   |
| AC INPUT         | Green - ON       | Input voltage is within specified range.   |
|                  | Green - Flashing | Input voltage is over specified range.   |
|                  | Green - OFF      | No input voltage or low input voltage.   |

NOTE: Online/Fault LEDs are dual diodes (Red and Green.) Amber is caused by Red and Green LED's turning on together.

## 9.3 LCD Display - Open the Main Menu

- The LCD Display can display up to four lines of 20 characters across.
  - Each screen is either a Menu or Data display.
  - The right-most column may display an up (↑) and/or down (↓) arrow, indicating more choices in the indicated direction. Selection is made by moving the pointer (→) along the left side of the display, up and down using the up/down push buttons (Fig 9-1 (2) (▲) & (3) (▼)).
1. When the UPS initially starts, the STATUS screen will be displayed. Use the down push button (Fig. 9-1(3)) to move the pointer down until the pointer is next to MENU. Press the Select push button (Fig. 9-1(5)).
  2. The **\*\*MENU\*\*** will open.

## 9.4 LCD Display - Menu/Sub-Menu Navigation

- The LCD Display can display up to four lines of 20 characters across.
- A screen displays either Menu Options or Data parameters.
- The right-most column may display an **up** (↑) and/or **down** (↓) **arrow**, indicating more choices in the indicated direction. Selection is made by moving the **pointer** (>) along the left side of the display, up and down using the up/down push buttons (Fig 9-1 (2 & 3)).

Example:

1. When the main Menu display opens, the selection pointer initially points at **Quick Config**. (Fig. 9-2a) The downward pointing arrow in the right-hand column indicates you are at the top of the sub-menu list, and there is at least one more selection after the current one.

2. Press the down (▼) push button (Fig. 9-1(2)). The selection pointer moves one line down, to **Monitor**. (Fig. 9-2b)

Now the up and down arrows are displayed in the right-hand column. This indicates there is at least one selection above and below the current selection.

3. Pressing the down push button moves the selection pointer to **Settings**. (Fig. 9-2c)

4. Pressing the down push button once more causes the displayed sub-menu entries to move up one line. The new submenu **Records** is displayed in the bottom line and is pointed to by the selection pointer (>). (Fig. 9-2d)

5. **Records** is the last available sub-menu selection under Menu as indicated by the lack of a down arrow in the right hand column.

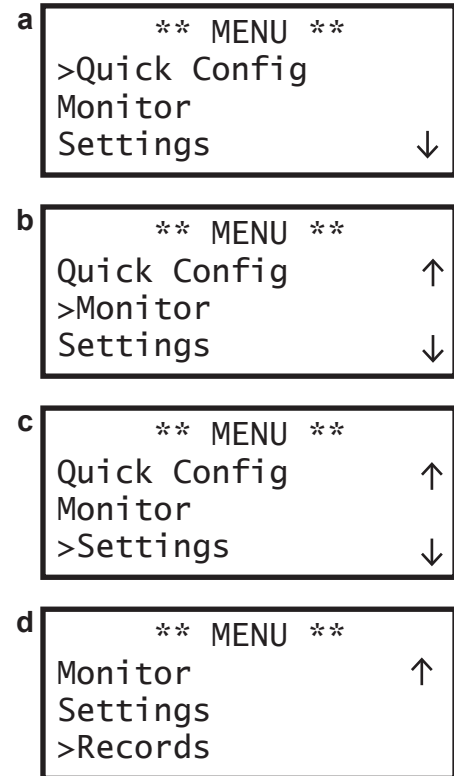


FIGURE 9-2: MENU DISPLAY

### 9.5 LCD Display - Sub-Menu/Parameter Navigation

Sub-menus have parameters that can be monitored and/or adjusted.

Example:

1. Open **MENU** and select sub-menu **Settings**, (Fig. 9-3a) by pressing the **ENTER/MENU** push button (Fig. 9-1 (5)).
2. Arrow down to sub-menu **Output** (Fig. 9-3b) and press **ENTER/MENU**.
3. Arrow down to the parameter **Rated Vout\*** (Fig. 9-3c) .
4. The parameter values display is different than the Menu/ Sub-menu/Parameter lists.

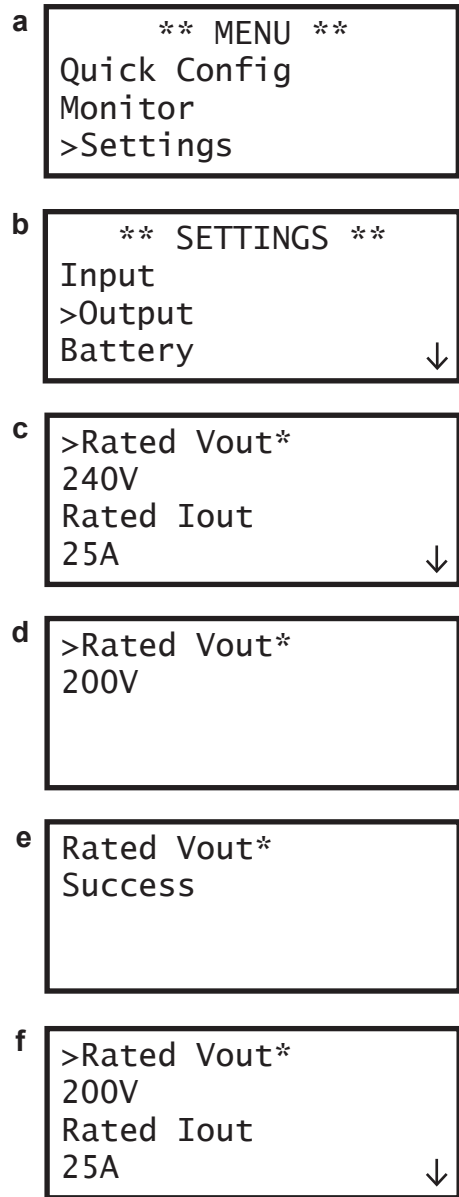
Each parameter takes two lines:

- The first line is the parameter name.
  - The second line is the parameter value. (Fig. 9-3c)
5. Select the parameter **Rated Vout**. The parameter selection display will open. It will display only one option at a time.

Scroll through the available choices using the up and down push buttons until the correct value is displayed (Fig. 9-3d).

6. Press **ENTER/MENU** to load the new value. When the new value is accepted, the display returns "Success". (Fig. 9-3e)
7. Press the **ESC/MUTE** push button (Fig. 9-1(4)) to return to the parameter screen (Fig. 9-3f).
8. Cycle power to the UPS to implement the new value. Do this for any changes to parameters followed by an asterisks (\*).

The shorthand for this operation is expressed: MENU > SETTINGS > OUTPUT > Rated Vout > Rated Vout: 200V



**FIGURE 9-3: PARAMETER DISPLAY**



## 10. UPS Operation

### 10.1 Initial Startup

The following parameters need to be input before connecting the load to the UPS. The most convenient access is to use the **Quick Config** menu using the example in Section 9.4.

See Section 9 for control panel explanations and display navigation.

1. Ensure no loads are connected to the UPS outlets.
2. Apply power to the T1000 UPS System. Switch on MCCB1. The **ONLINE/FAULT** LED will briefly illuminate, then turn off.
3. In Bypass, the UPS **ONLINE/FAULT** LED should be Off, and the **AC INPUT** LED a steady Green.
4. Access the **MENU**, open **QUICK CONFIG**, and ensure the following parameters are set properly. When changing/entering a new value, be sure to press the **ENTER/MENU** push button and verify the screen returns a **Success** message.
  - Input Voltage - Select the input voltage to the UPS.  
Path: **MENU > QUICK CONFIG > Rated Vin > Rated Vin: xxxV**
  - Output Voltage - Select the output voltage to the Load.  
Path: **MENU > QUICK CONFIG > Rated Vout > Rated Vout: xxxV**
  - Vout Adjust - Increase/decrease the output voltage slightly to compensate for line losses.  
Default - 0V  
Path: **MENU > QUICK CONFIG > Vout Adjust > Vout Adjust: xxV**
  - Battery Installation Date - Set during factory testing. Reset when battery modules are replaced.  
Path: **MENU > QUICK CONFIG > Batt Ins Date > Batt Ins Date: mm/dd/yyyy**
  - UPS Date - Current Date. Set at the factory and backed up by an internal battery. Only change when necessary.  
Path: **MENU > QUICK CONFIG > UPS Date > UPS Date: ddd mm/dd/yyyy**
  - UPS Time - Current time. Set at the factory for US Central Standard Time and backed up by an internal battery. Only change when necessary.  
Path: **MENU > QUICK CONFIG > UPS Time > UPS Time: hh:mm AM/PM**
  - Enable Batt Test - Enable or disable battery testing. Default - Enable.  
Path: **MENU > QUICK CONFIG > En Batt Test\* > En Batt Test Sup\* > En Batt Test\*: Enable/Disable**
5. Press the **ESC/MUTE** push button until the **STATUS** screen is displayed.
6. Leave the Power Module in bypass mode to allow the battery module(s) to charge for 24 hrs. before placing the Power Module online.



**ALLOW 24 HOURS FOR THE POWER MODULE TO RECHARGE THE BATTERY MODULE(S) BEFORE PLACING THE UPS IN SERVICE.**

7. Place the UPS online by pressing and momentarily holding the **RUN/STOP** push button. The **ONLINE/FAULT** LED should glow steady GREEN.

**NOTE:** Bypass is automatically disabled if the **Rated Vin** and **Rated Vout** are different.



## 10.2 Startup (Normal)

Once the initial operating parameters have been set (Section 10.1), the UPS can be started from a shutdown condition by following these steps:

1. Switch on MCCB1. The **ONLINE/FAULT** LED will briefly illuminate, then turn off.  
**ONLINE/FAULT** LED - Off  
**AC INPUT** LED - Steady Green
2. Press and momentarily hold (~2 sec.) the **RUN/STOP** push button until it beeps. The **ONLINE/FAULT** LED should glow steady green.  
**ONLINE/FAULT** LED - Steady Green  
**AC INPUT** LED - Steady Green
3. The UPS is now Online.

## 10.3 Bypass

The UPS can be placed in Bypass by following these steps:

**NOTE:** *The UPS can be placed in Bypass mode only if the Input and Output voltage parameters are set the same (e.g. 240 Vin/240 Vout, 208 Vin/208 Vout). Bypass is disabled if the Input and Output voltage parameters are different.*

### UPS is Initially OFF

1. Switch on MCCB1. The **ONLINE/FAULT** LED will briefly illuminate, then turn off. The UPS is in Bypass.  
**ONLINE/FAULT** LED - Off  
**AC INPUT** LED - Steady Green *(If the AC INPUT LED is Off, then Bypass has been disabled. See 10.3 NOTE.)*

### UPS is Initially ONLINE

1. The Online state will show:  
**ONLINE/FAULT** LED - Steady Green  
**AC INPUT** LED - Steady Green
2. Press and momentarily hold (~2 sec.) the **RUN/STOP** push button until it beeps. The **ONLINE/FAULT** LED will turn off.  
**ONLINE/FAULT** LED - Off  
**AC INPUT** LED - Steady Green *(If the AC INPUT LED is Off, then Bypass has been disabled. See 10.3 NOTE.)*

## 10.4 Shutdown

The UPS can be Shutdown (turned off) by following these steps:

### UPS is Initially ONLINE

1. The Online state will show:

**ONLINE/FAULT** LED - Steady Green  
**AC INPUT** LED - Steady Green

2. Press and momentarily hold (~2 sec.) the **RUN/STOP** push button until it beeps. The **ONLINE/FAULT** LED will turn off.

**ONLINE/FAULT** LED - Off  
**AC INPUT** LED - Steady Green *(If the AC INPUT LED is Off, then Bypass has been disabled. See 10.3 NOTE.)*

3. Remove power from the T1000 UPS System. Switch off MCCB1. The **AC POWER** LED will turn off.

**ONLINE/FAULT** LED - Off  
**AC INPUT** LED - Off

### UPS is Initially in BYPASS

1. The Bypass state will show:

**ONLINE/FAULT** LED - Off  
**AC INPUT** LED - Steady Green

2. Remove power from the T1000 UPS System. Switch off MCCB1. The **AC POWER** LED will turn off.

**ONLINE/FAULT** LED - Off  
**AC INPUT** LED - Off

### UPS is Initially in BACKUP

1. The Backup state will show:

**ONLINE/FAULT** LED - Steady Green  
**AC INPUT** LED - Off

2. Remove power from the T1000 UPS System. Switch off MCCB1. The **AC POWER** LED will then turn off.

**ONLINE/FAULT** LED - Off  
**AC INPUT** LED - Off

## 11. System Description

An uninterruptible power system (UPS) is a system that is installed between the commercial power and the load equipment. The UPS provides steady AC output power during commercial power short-term interruptions such as blackouts or brownouts. This power is provided for a sufficient amount of time so that the load can be shut down in an orderly fashion. This prevents loss of data and possible damage to both hardware and software.

During normal operation, the UPS uses commercial AC power. It absorbs high voltage spikes and transients caused by switching and faults, and the common-mode and normal mode noise which is associated with commercial AC power. The UPS converts it all to clean DC power. From this power, the UPS charges its batteries and generates its own extremely high quality AC waveform output. The result of this process is maximum power conditioning and regulation.

If the AC power supplied to the UPS drops below a specified voltage level, the unit's batteries automatically begin supplying power instead of receiving it. This insures that the loads connected to the UPS continue to receive power with no interruption (as long as the backup batteries hold up). When AC input power becomes available again, operation returns to normal, and the unit's batteries begin to recharge so they will be ready for the next power interruption.

### 11.1 Application and Use

In Online Mode the Toshiba T1000 UPS provides continuous computer-grade AC power in a compact, high performance, and energy efficient unit. The UPS unit ensures safe and reliable operation of critical office equipment. All units feature an audible alarm which sounds if the battery voltage drops below a specified minimum during use. This is an additional aid to help protect valuable office data banks. All units allow for computer interfacing.

### 11.2 Power Backup

When an electrical power failure occurs, the UPS's internal batteries automatically supply back-up power to the load without interruption. For example, when used to support a computer, the UPS back-up assures enough additional time to complete the activity and store the data. This allows an orderly shutdown of critical equipment.

The T1000 minimum input voltage,  $V_{IUV}$ , is 85% of the nominal input voltage of 240V at full load.

### 11.3 Power Conditioning

When commercial power is present, the UPS supplies conditioned power to the load while maintaining its batteries in a charged condition. The UPS protects against the normal, everyday problems associated with unreliable commercial power, including power sags, surges, signal interference, and spikes. This protection keeps power-line problems from reaching your load, where they can cause equipment to operate erratically, or damage software and hardware.

During brown-out conditions, where the utility power momentarily drops below the minimum 85% of nominal input voltage, the UPS will transfer to backup mode. Once the input voltage increases above 85% of nominal input voltage, the UPS will automatically retransfer to Online Mode.

## 12. Operating Modes

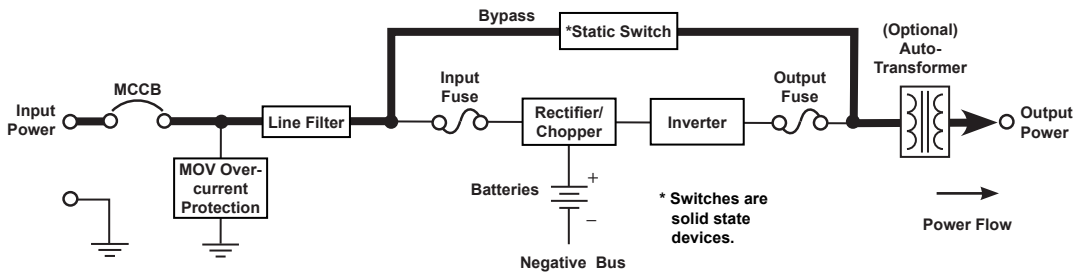
### 12.1 Static-Bypass (Stop operation)

During power up the UPS starts up in Bypass mode except when:

- Performing cold start operation.
- Performing frequency conversion.
- When input and output voltages are unequal causing bypass to be disabled.

If the UPS unit is severely overloaded or develops an internal fault, power flow is automatically switched from the unit's main circuit to the bypass circuit. Power flow through the bypass is shown in the following illustration. This change-over occurs automatically in phase in less than one-quarter cycle of the input waveform. The switching period is not long enough to cause interruptions to occur in most loads.

- If the power flow is transferred to the bypass circuit due to an internal fault the UPS will continue to supply power to the load through the bypass and indicate a system fault message (see "16.3 System Fault Messages" on page 49).
- If the power flow is transferred to the bypass circuit due to an overload condition (see "16.4 System Warning Messages" on page 50), then the power flow will automatically transfer from the UPS's bypass circuit back to the inverter circuit after removing the overload if set to do so (Under **Setting > Status Config & Ctl**, set **En AutoXfer** to **Enable**).

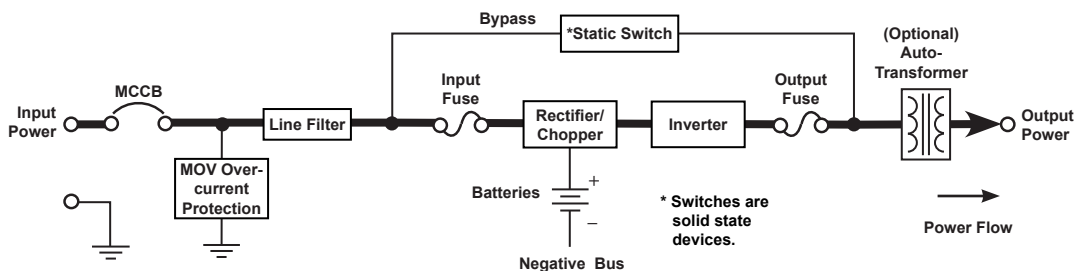


**FIGURE 12-1: POWER FLOW IN BYPASS FOR ALL MODELS**

NOTE: Bypass will be automatically disabled if the rated input and output voltages or frequencies are different.

### 12.2 On-Line (Run operation)

The following illustration shows circuit power flow when the UPS is operating normally in the Online Mode. The UPS rectifier, including a boost chopper circuit, converts AC input power to DC power. The boost chopper circuit maintains a constant voltage, with current limiting, for charging the batteries. The inverter section generates a high quality sinusoidal output voltage. The unit's batteries are always maintained in a constantly charged state when the UPS is in the run operation mode.

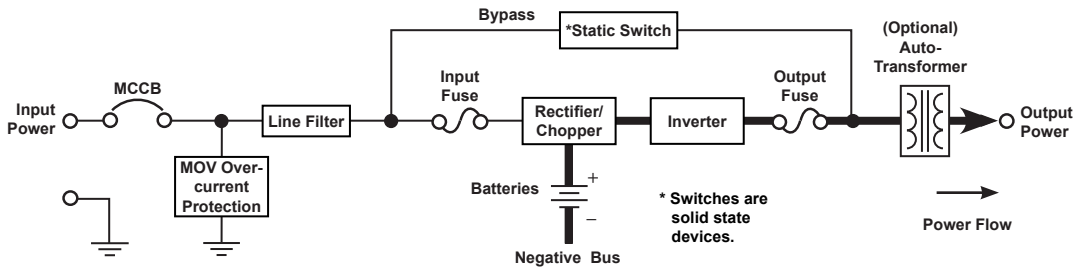


**FIGURE 12-2: POWER FLOW IN ONLINE MODE FOR ALL MODELS**

### 12.3 Battery Backup (On batteries)

The following illustration shows power flow during the battery backup mode. When commercial AC power failures occur, the UPS's batteries instantly begin supplying DC voltage to the UPS's main inverter circuit. This circuit changes (inverts) the DC power into AC power. The AC power is available at the output of the unit.

This back-up process will continue until the UPS's battery voltage drops below a specific minimum level. When this occurs, the batteries will stop supplying power to the load. This minimum level is the rated minimum voltage ( $V_{min}$ ). The rated battery voltage chart on page 33 shows ( $V_{min}$ ). The battery backup time and discharge process is explained on page 33.



**FIGURE 12-3: POWER FLOW IN BATTERY BACKUP FOR ALL MODELS**

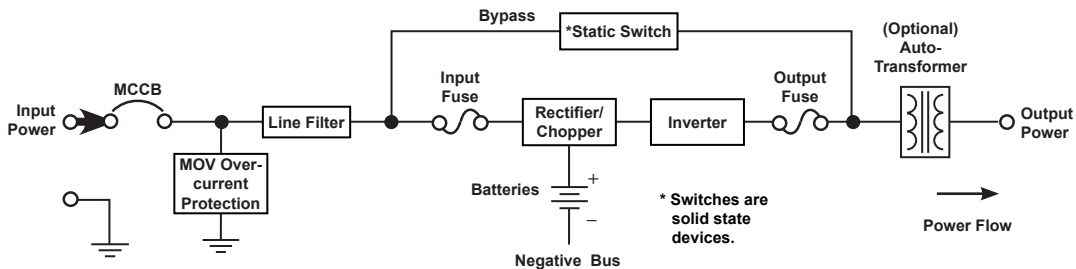
### 12.4 EPO (Emergency Power Off) Function

These units are equipped with terminals for receiving an emergency power-off (EPO) command via a closed-contact switch at a remote location (see Terminal Block Details on Table 7-1, and terminal block location in Section 7.1). This safety feature enables quick shut-down of the UPS's AC input breaker, output and battery circuits.

Usually the emergency power off switch is installed in a central location that is easily accessible to personnel concerned with the operation of the UPS unit and the load equipment connected to it. The EPO function is initiated by pressing the switch to the closed (shutdown) position.

The effect of using the EPO switch is the same whether the UPS unit is in AC input mode, battery backup mode, or the circuit bypass mode. The following figure shows the UPS condition after application of the EPO switch.

*NOTE: EPO operation should be limited to no more than 4 operation per minute, or 24 operations per hour. Exceeding this duty cycle will overheat the EPO components*



**FIGURE 12-4: POWER FLOW AFTER AN EPO COMMAND FOR ALL MODELS**

## 12.5 Cold Start (On Batteries)

The following illustration shows power flow during Cold Start. When the UPS must be started, and utility power is not available, the UPS can be *Cold Started* (the UPS's batteries supply DC voltage to the UPS's main inverter circuit.) This circuit changes (inverts) the DC power into AC power. The AC power is available at the output of the unit.

NOTE: The default frequency mode is set to auto-detect. In auto-detect mode the default output frequency at turn-on and cold-start is 60 Hz.

This battery discharge process will continue until either:

- Utility power is restored and the UPS auto-transfers to online mode,
- The UPS's battery voltage drops below the Battery Shutdown voltage ( $V_{min}$ ) and the UPS shuts down power to the load and turns itself off. The nominal minimum voltage  $V_{min}$  is given in Table 12-1.

NOTE: The Battery-shutdown Voltage is automatically adjusted by the UPS based on load percentage in order to maximize battery life.

The battery backup time and discharge process is explained in Section 12.7 – 12.9.

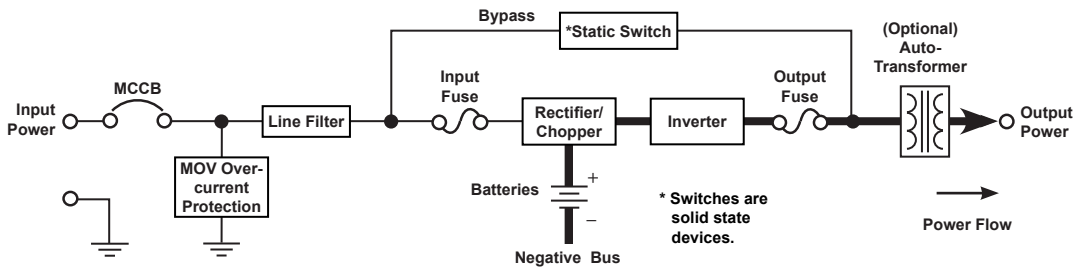


FIGURE 12-5: POWER FLOW IN BATTERY BACKUP FOR ALL MODELS

## 12.6 Frequency Conversion Mode (CVCF)

The default Frequency mode is Auto-detect; the Output frequency will be the same as the Input frequency: 60 Hz in and 60 Hz out, or 50 Hz in and 50 Hz out. In Auto-detect the parameter **CVCF** is set to **DISABLED**.

NOTE: Only **ENABLE** parameter **CVCF** if the desired output frequency is different that the input frequency.

To set the UPS for frequency conversion:

1. Access the menu parameter **Settings > Status Config & Ctl > EN CVCS** and select **ENABLED**.
2. Access the menu parameter **Settings > Status Config & Ctl > CVCF Frequency** and select the desired output frequency - either **50.0Hz** or **60.0Hz**.

NOTE: Ensure the load is disconnected before changing the CVCF parameter value.

3. Cycle power to the UPS to save the new parameter settings.

### Cold Start in Frequency Conversion Mode

The output frequency will be the selected output frequency **CVCF Frequency**.

### 12.7 Battery Backup Time and Discharge Process

The UPS battery module will provide approximately 5 minutes of back-up time per battery module when operating at full load at the rated power factor. The exact length of these times will depend on the condition of the batteries, amount and type of load, temperature and other variables. See battery backup time in “Appendix A: T1000 Specifications” on page A-3.

The following illustration graphically shows the battery discharge process at full load conditions.

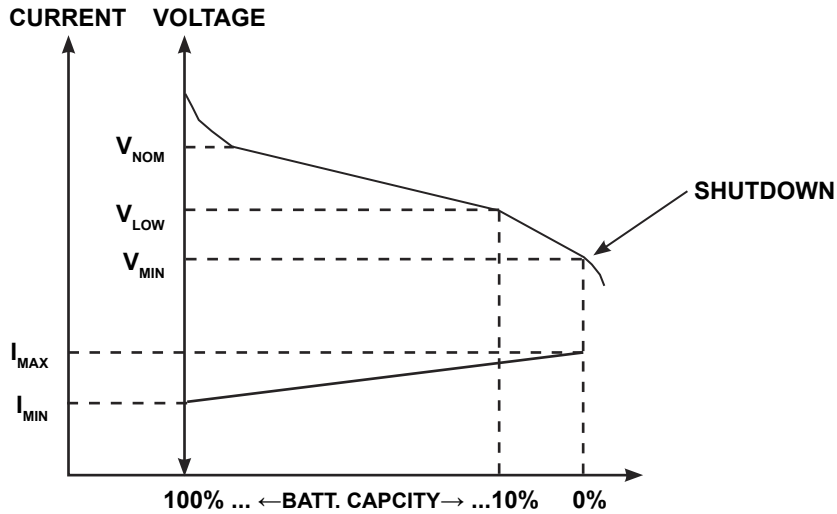


FIGURE 12-6: BATTERY DISCHARGE CURVES

### 12.8 Battery Low Voltage Tolerances

Excessive discharge will cause the UPS battery voltage to drop. The chart shown below lists the voltage level at which each UPS low-voltage alarm will sound when loaded to rated full load at 240V and at what level the low-voltage condition will cause the unit to automatically shut down.

TABLE 12-1: VOLTAGE TOLERANCES

| UPS Capacity                   | 6 kVA   |
|--------------------------------|---------|
| Nominal voltage ( $V_{NOM}$ )  | 216 Vdc |
| Alarm voltage ( $V_{LOW}$ )    | 194 Vdc |
| Shutdown voltage ( $V_{MIN}$ ) | 170 Vdc |

### 12.9 Battery Recharging

The illustration below shows a graphical representation of the UPS battery recharge process after a full discharge.

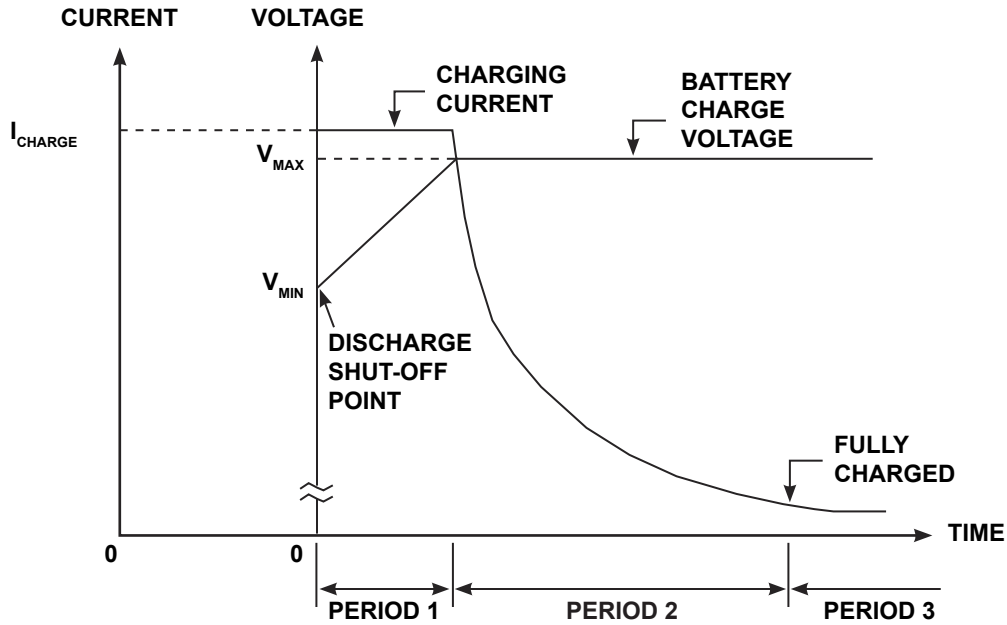


FIGURE 12-7: BATTERY RECHARGING PROFILE

The recharge process usually consists of three periods.

- During the first period, the current is maintained at approximately 1.0 ampere. This current limit is the maximum value that can be used to charge the batteries (for minimal recharge time) while assuring safety and long battery life.
- In the second period, constant-voltage control starts and current gradually decreases as the batteries charge to their normal fully charged state.
- In the third period, a slight trickle current continues to flow into the batteries to keep them fully charged and floating at the normal Vdc level.

A full recharge usually requires 24 hours (90% recharge in 4 hours) after a complete discharge.

The following chart shows the rated maximum and minimum battery voltages and the charge current for the UPS.

TABLE 12-2: RATED BATTERY VOLTAGES

| Model | Vmax (Float) | Vmin  | Icharge |
|-------|--------------|-------|---------|
| 6 kVA | 246 V        | 170 V | 1.0 A   |



## 12.10 Battery Test

See Fig. 9-1 for a detailed description of the LCD display layout and controls for the T1000 UPS.

The T1000 allows the user to conduct automatic battery test on startup, or manual battery tests at daily, weekly, or monthly intervals. The following steps detail the battery test procedures.

### **Battery Test on Startup:**

1. Navigate to **MENU > Setting > Status Config & Ctl > En Batt Test Sup\*** and set it to “Enable”.
2. Navigate to **MENU > Setting > Status Config & Ctl > En Batt Test\*** and select “Enable” to allow the battery test to be performed.
3. The Battery Test on Startup is performed only if it is enabled during startup. Restart the UPS to perform the battery test on startup.

### **Manual Battery Test**

A Batt Test can be manually initiated once every interval selected in **Batt Test Freq**.

**Batt Test Freq** sets an internal lockout timer that prevents manual testing more frequently than the interval selected (0 = Daily, 1 = Weekly, 2 = Monthly). To repeat the test more often, cycle power to the UPS to reset the Batt Test\* lockout timer.

The **Batt Test Freq** lockout timer is initiated when a manual test is performed, or after a Batt Test on Startup is enabled, and prevents Battery testing until the timer counts down to zero.

**NOTE: If the UPS is connected to the load and the batteries are either depleted or bad, power to the load may be interrupted when a battery test is conducted.**

The UPS must be in Online mode.

#### ENABLE MANUAL BATTERY TESTING

1. Navigate to **MENU > Setting > Status Config & Ctl > En Batt Test\*** and select “Enable” to allow the battery test to be performed.
2. Navigate to **MENU > Setting > Status Config & Ctl > Batt Test Freq** and select the desired minimum wait time between battery tests: 0 = Daily, 1 = Weekly, 2 = Monthly.

#### CHECK Batt Test Freq LOCKOUT TIMER

3. Navigate to **MENU > Monitor > Status Config & Ctl > Batt Test Cond.**
  - If the display shows “Ready for Test”, test can be initiated. GO TO STEP 4.
  - If the display shows “Test Prohibit”, the lockout timer is still counting down and the test can not be initiated. If the test must be performed before the lockout timer clears, cycle power to the UPS, then repeat Step 2.

#### PERFORM BATTERY TEST

4. Navigate to **MENU > Setting > Status Config & Ctl > Requested State** (the first entry under **Status Config & Ctl**) and select “Batt Test”.
  - If the test passes, the display returns to the Monitor screen.
  - If the test fails, the display returns to the Monitor screen and displays BTSTFL in the warning section at the bottom left of the display, and the “Warning” LED blinks until the fault is no longer detected.

***Batt Test\*** failure may be caused by a loose battery cable. Verify the cables are properly connected and rerun the test. If **Batt Test\*** fails again, there is a failure in the Battery Module. Disconnect the battery module from the UPS and re-run the test. This will clear the BTSTFL fault.*

## 13. Control Panel Menu Trees

### 13.1 Control Panel Navigation and Menu Access

See Fig. 9.1 for a detailed description of the LCD display layout and controls for the T1000 UPS.

There are four options available under the selection **MENU**. Only **Quick Config** and **Settings** allow the user to change parameter settings.

The Menu Trees are laid out in Sections 13.2 – 13.4.

Details of the menu entries are listed in “Appendix B: T1000 Menu Table”.

### 13.2 Top Menu - Sub-Menu Tree

The opening display offers current status, input/output values, and the MENU selection. Selecting the **MENU** allows the operator the options shown in Fig. 13-2.

Parameter changes can only be made through the **QUICK CONFIG** or **SETTINGS** sub-menus.

Changing a parameter with a single asterisk (\*) by it in **QUICK CONFIG** or **SETTING**, such as **EN Batt Test\*** and **En Startup Delay\***, requires the user to cycle power to the UPS to activate the selected value.

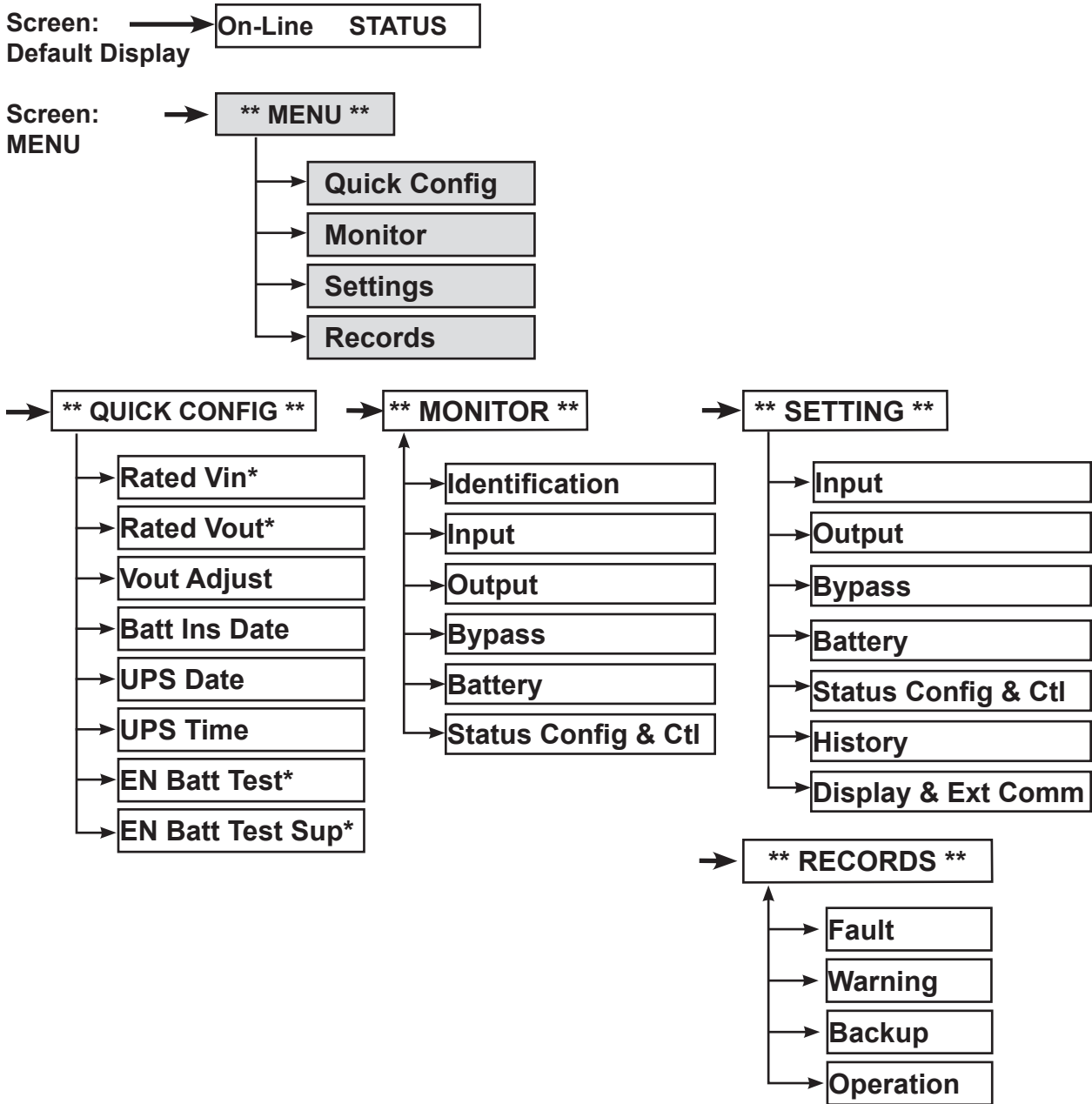


FIGURE 13-1: TOP MENU

13.3 Monitor Sub-Menu/Parameter Tree

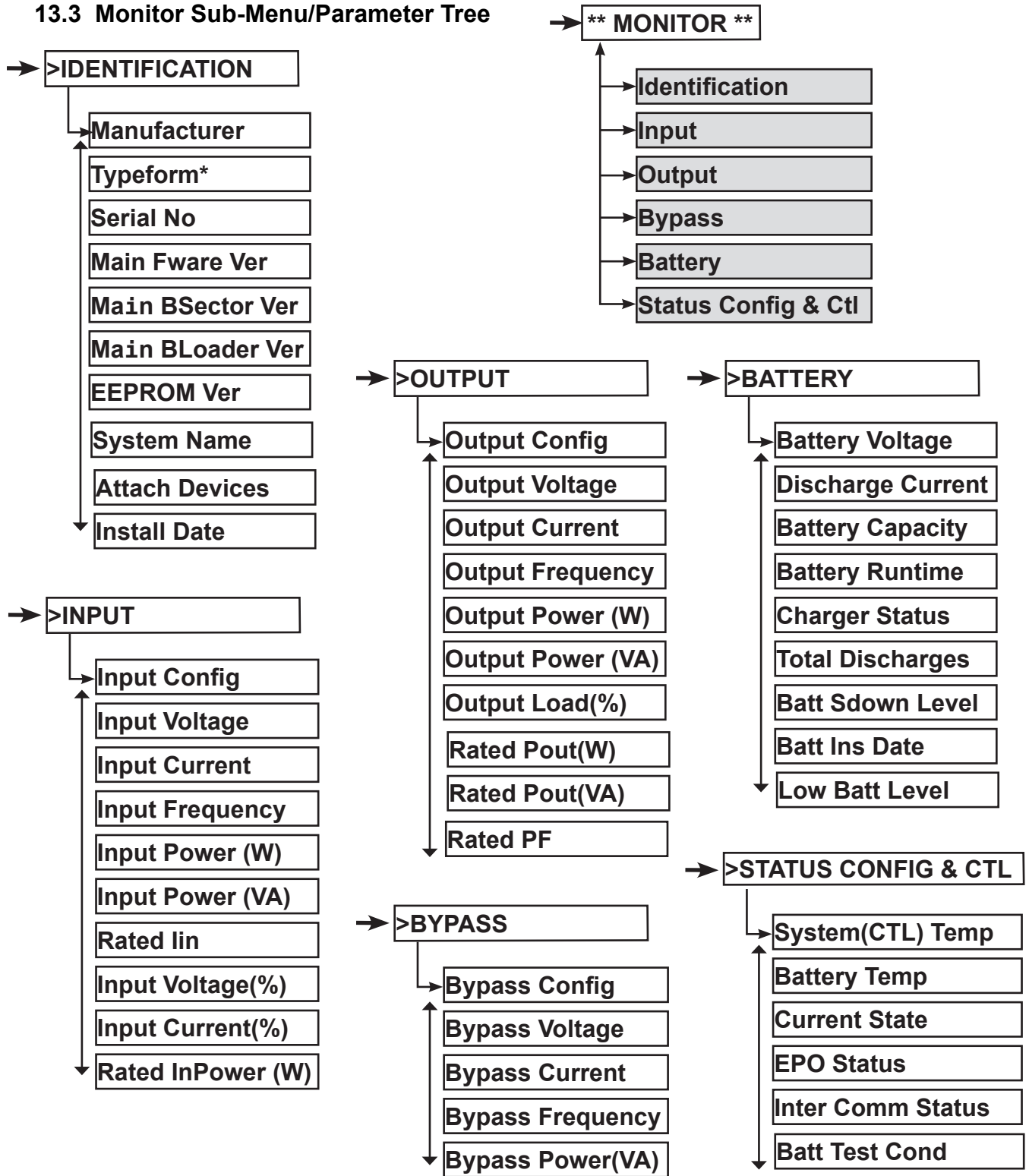


FIGURE 13-2: MONITOR MENU AND SUB-MENUS

### 13.4 Setting Sub-Menu/Parameter Tree

Parameter changes can be made using the SETTINGS menu.

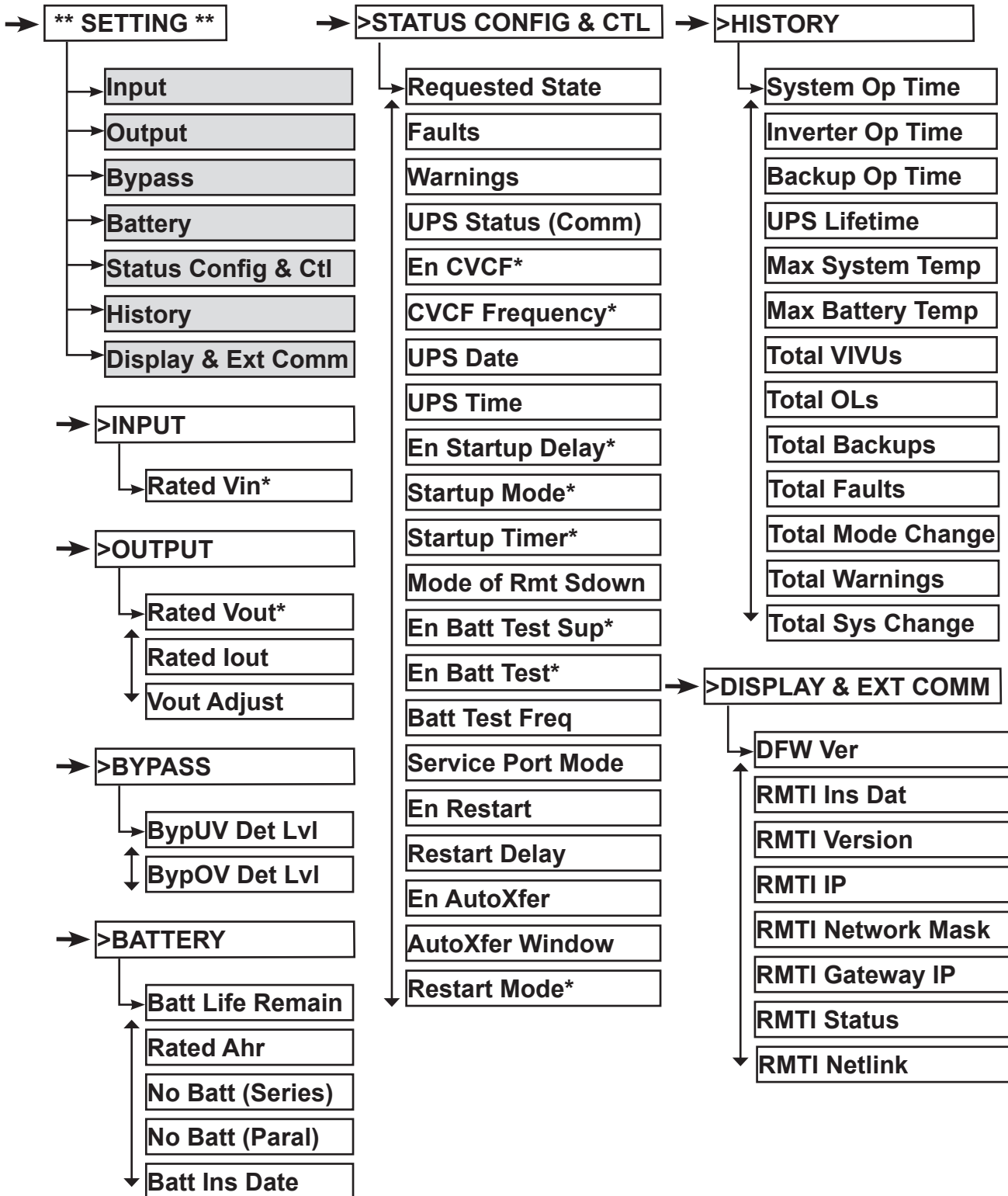
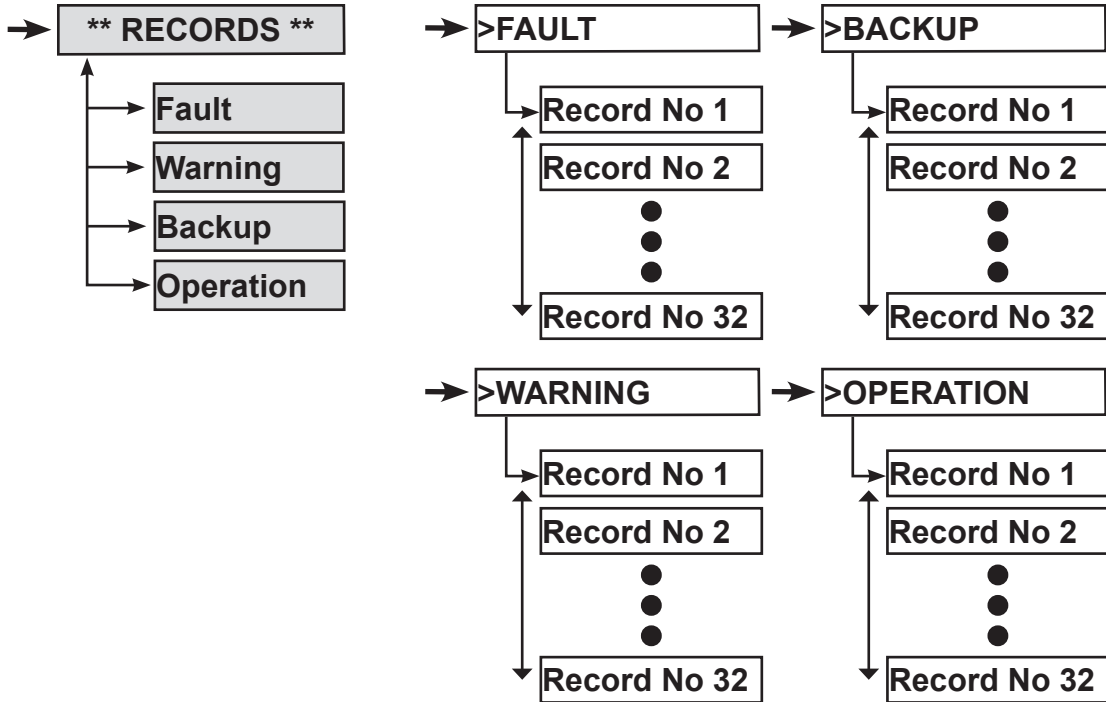


FIGURE 13.3: SETTING MENU AND SUB-MENUS

**13.5 Records Sub-Menu/Parameter Tree**



**FIGURE 13-4: RECORDS SUB-MENU**

FAULT RECORD FORMAT

Rec No. nn  
mm/dd/yyyy hh:mm:ss  
FR:(from mode)(Factory Svc. Code)  
TO:(to mode) C:252

Example:

|                     |   |
|---------------------|---|
| Rec No. 17          | ↑ |
| 01/05/2014 22:28:23 |   |
| FR:Bypass B:66      |   |
| TO:On-Line C:252    | ↓ |

WARNING RECORD FORMAT

Rec No. nn  
mm/dd/yyyy hh:mm:ss  
F1:0x(Hex) F2:0x(Hex)  
F3:0x(Hex)

Example:

|                     |   |
|---------------------|---|
| Rec No. 170         | ↑ |
| 01/23/2014 10:36:10 |   |
| F1:0x0 F2:0x0       |   |
| F3:0x80             | ↓ |

BACKUP RECORD FORMAT

Rec No. nn  
mm/dd/yyyy hh:mm:ss  
W1:0x(Hex) W2:0x(Hex)  
W3:0x(Hex)

Example:

|                     |   |
|---------------------|---|
| Rec No. 129         | ↑ |
| 01/23/2014 10:36:10 |   |
| W1:0x0 W2:0x4       |   |
| W3:0x0              | ↓ |

OPERATION RECORD FORMAT

Rec No. nn  
mm/dd/yyyy hh:mm:ss  
(Message): (Duration)  
SOURCE: (Source Code)

Example:

|                     |   |
|---------------------|---|
| Rec No. 1139        | ↑ |
| 01/12/2014 07:30:47 |   |
| ON BATT (SEC): 19   |   |
| SOURCE: 2           | ↓ |

**FIGURE 13-5: RECORD FORMATS**

## 14. Operation

### 14.1 Cold Start

Cold Start is the process of starting a UPS up in backup mode in the absence of Utility power.

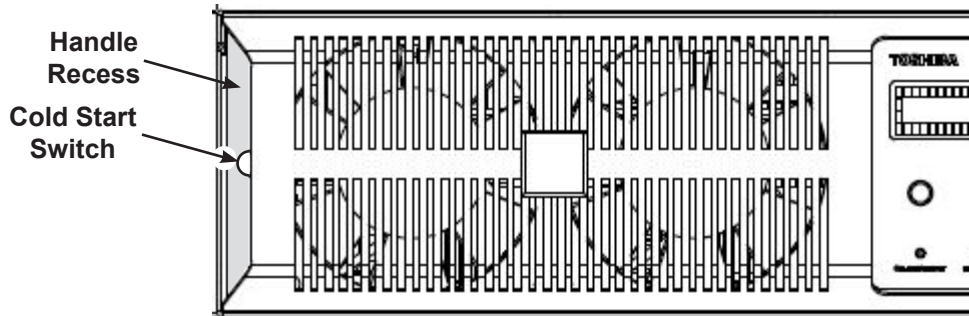
To cold start the T1000, perform the following steps:

NOTE: If the unit is configured for frequency auto-detect (the default shipping mode), the default output frequency for a cold start is 60Hz.

1. Ensure the battery module(s) are plugged in.
2. Ensure the Input/Utility power to the UPS is disconnected.
3. Disconnect the load from the UPS output when performing a cold start. If this is not possible, ensure the load does not exceed the rated output of the UPS.
4. Close the MCCB1 circuit breaker located on the back of the UPS.

NOTE - Ensure the input voltage is set to less than or equal to the output voltage.

5. Press (no holding required) the cold start button located opposite the front panel display. It is partially obscured by the handle recess. (Fig. 14-1)



**FIGURE 14-1: COLD START SWITCH LOCATION**

6. The transition from Cold Start to Online is automatic once the utility power is connected.

NOTE: After starting in Cold Start, if you press **START/STOP** while still in backup (before utility power is restored) the unit will go into shutdown.

### 14.2 EPO and Remote Stop

There are two terminal blocks, designated **EPO** and **Rem. Stop**, for connecting switches to the UPS to allow remotely (100 m) Stopping or Shutting Down the UPS by pressing a switch. (See Fig. 14-2)

#### **EPO (Emergency Power Off)**

The EPO is triggered by an external switch.



The EPO terminals provide 208/240Vac (same as UPS output terminals). The external switch should be rated for a minimum of 300Vac and 300mA.

When the EPO switch is closed, the Input circuit breaker to the UPS opens and all power to the unit is removed, including backup power from the batteries.

NOTE: EPO operation should be limited to no more than 4 operations per minute, and no more than 24 operations per hour. Exceeding this duty cycle will overheat the EPO circuits.

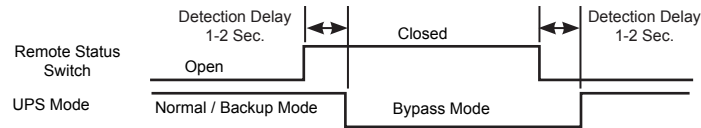
**Remote Stop**

The Remote Stop is triggered by an external NO (Normally Open) dry contact switch. Power to the Remote Stop switch is about 10Vdc, and less than 20mA.

When the Remote Stop switch is closed, the UPS transfers from Normal/Backup to Bypass after a 1 – 2 sec. detection delay. (See the diagram below)

When the closed Remote Stop switch is opened, the UPS transfers from Bypass back to it's initial state (Normal/Backup) after a 1 – 2 sec. detection delay.

If the UPS is in bypass when the Remote Stop is closed, no action is taken.



**FIGURE 14-2: REMOTE STATUS SHUTDOWN TIMING**



## 15. Communication Interfaces

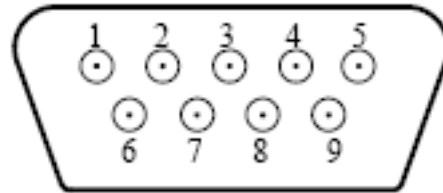
### 15.1 Remote Contacts

The remote contacts interface is provided as a set of solid state switching devices. The switches are available through a DB9 male connector on the rear of the UPS. The following chart shows the pin assignment for each signal.

**MAXIMUM CURRENT CARRYING CAPACITY OF THE SWITCH**

| Voltage                     | Current                   |
|-----------------------------|---------------------------|
| 48 Vdc peak                 | 70 mA peak                |
| 30 Vac rms<br>(42 Vac peak) | 50 mA rms<br>(70 mA peak) |

**DB9 MALE CONNECTOR OUTLINE (FACING CONNECTOR)**



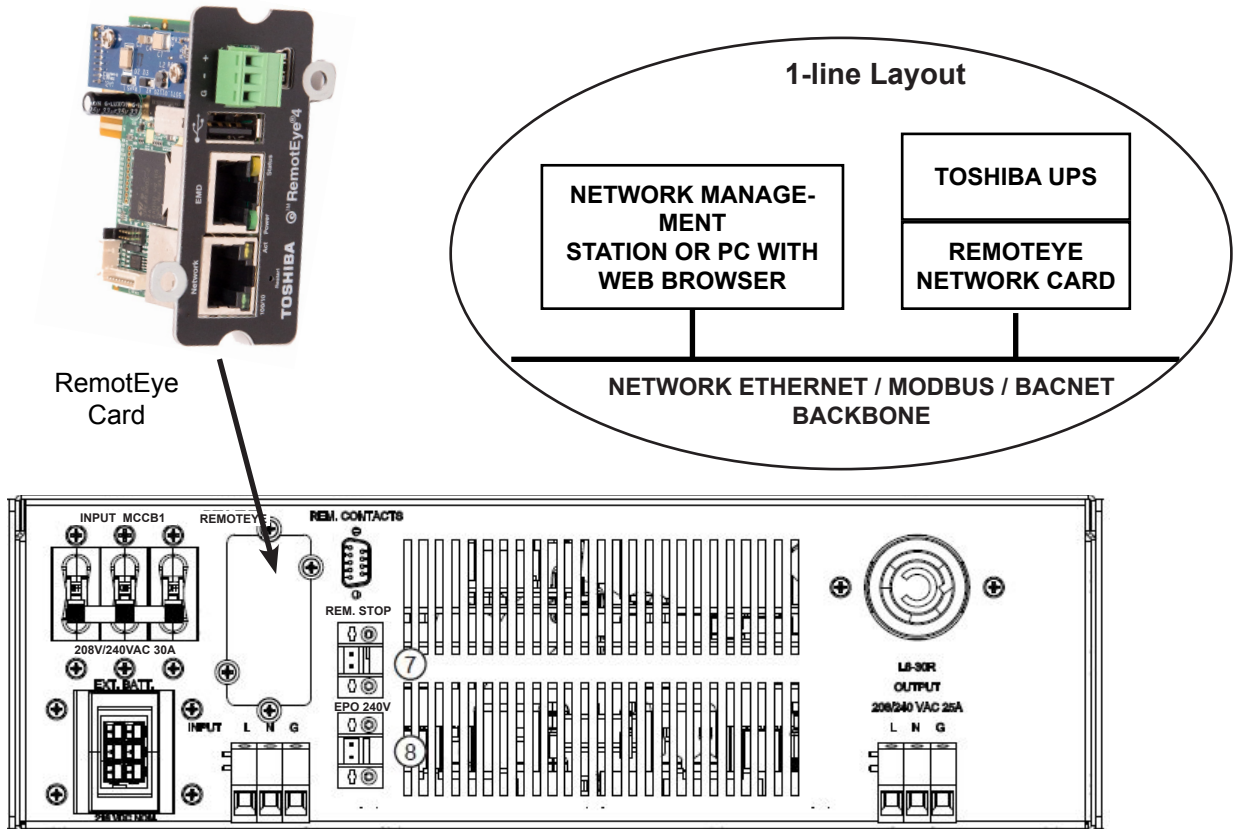
| Pin | Signal Function                      | Logic<br>NO - Normally Open<br>NC - Normally Closed                             | In the UPS |
|-----|--------------------------------------|---|------------|
| 1   | Fault Signal                         | NO - Closed when fault detected   |            |
| 2   | UPS stop common                      | Backup stop when the level changes from Low (-3 to -15 V) to High (+3 to +15 V) |            |
| 3   | UPS stop (LAN Shutdown) signal input |   |            |
| 4   | Normal input power supply            | NO - Closed with normal Input Voltage   |            |
| 5   | Signal common                        | Common signal return  |            |
| 6   | Bypass operation                     | NO - Closed during bypass operation   |            |
| 7   | Low Battery                          | NO - Closed at voltage drop   |            |
| 8   | UPS operation                        | NO - Closed during inverter operation   |            |
| 9   | Backup signal                        | NO - Closed at power failure  |            |

**NOTE:** Pin switches are shown in their inactive states. For example, if battery voltage is low, pin 7 will be connected to pin 5.

**FIGURE 15-1: REMOTE CONTACTS PINOUTS**

## 15.2 (Optional) RemotEye® Network Card

The RemotEye is an optional network card for the Toshiba UPS. This card slides into a slot located on the back side (See illustration) of the UPS. The card provides a network, or LAN-based communication interface for the UPS. When installed, the UPS can be managed remotely using the common SNMP and HTTP web-based network protocols. The following diagram shows the flow of the Network Management Station.



**FIGURE 15-2: REMOTEEYE INSTALLATION**

15.2.1 To install the RemotEye network card, Follow the steps below:

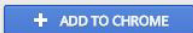

1. The RemotEye network card can be installed with the power module energized or not.
2. Remove the blank cover plate over the RemotEye option slot.
3. Slide the RemotEye printed circuit board into the extension option slot of the UPS.
4. Secure the printed circuit board using the UPS supplied screws.
5. See the RemotEye User Manual to complete the hardware setup and software setting for proper RemotEye operation.

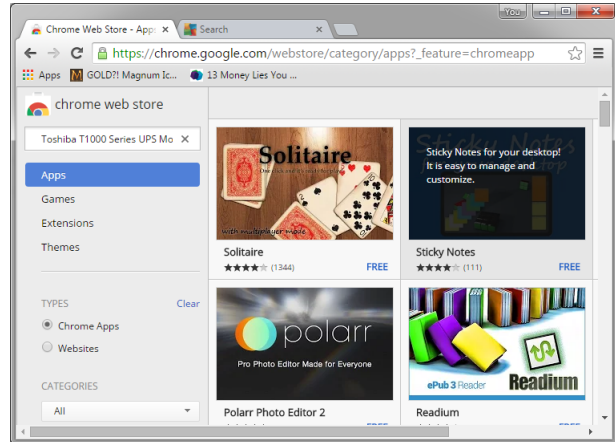
### 15.3 (Optional) Google Chrome™ Browser App

The Google Chrome browser app “**Toshiba T1000 Series UPS Monitoring Program**” allows any digital device running the Google Chrome browser to monitor the T1000 UPS via a cable to the USB port. The Monitoring app only allows passive monitoring of the UPS performance.

The monitoring app can be run concurrently with the RemotEye Network card.

Requirements: Google Chrome™ web browser and Google Gmail™ webmail account.

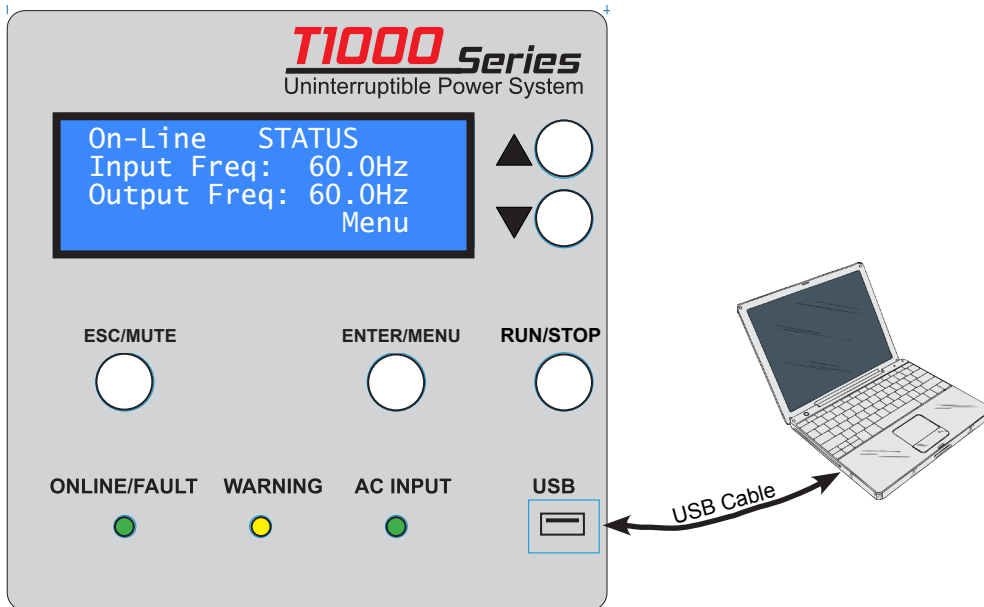
1. Download and install the Google Chrome browser if it’s not already on your monitoring platform.
2. Create a Google email (Gmail) account if you don’t have one.
3. Log in to the Chrome Web Store:  
<https://play.google.com/store> (Figure 15-3)
4. Find and select the “**Toshiba T1000 Series UPS Monitoring Program**” app. (See Figure 15-4)
5. Click [ + ADD TO CHROME ]. 
6. To monitor a T1000 Series UPS, connect the device running the monitoring program to the T1000 USB port. (See Figure 15-5)
7. Click on the  app icon to start the Monitoring app.



**FIGURE 15-3: GOOGLE CHROME APP STORE**



**FIGURE 15-4: GOOGLE CHROME APP ICON FOR “TOSHIBA T1000 SERIES UPS MONITORING PROGRAM”**



**FIGURE 15-5: CABLING THE T1000 TO A PLATFORM RUNNING THE “TOSHIBA T1000 SERIES UPS MONITORING PROGRAM”**

### 15.4 (Optional) EMD

The **Environmental Monitoring Device (EMD)** is a monitoring device that provides real time comprehensive remote monitoring of environment temperature and environmental humidity via the RemotEye® Network Card.

The EMD also provides two user-defined dry contacts for additional monitoring.

These dry contacts can be used with devices that provide normally-open or normally-closed results, such as door sensors, smoke detectors, motion detectors, and liquid detectors.

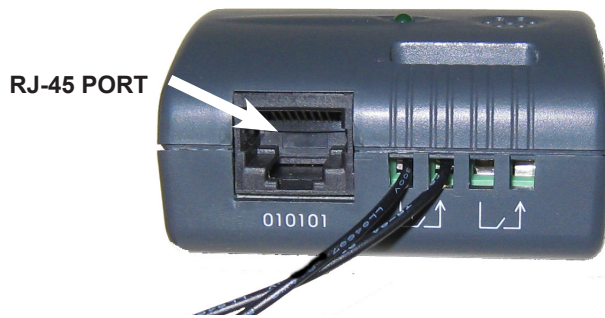


FIGURE 15-4: (OPTIONAL) ENVIRONMENTAL MONITORING MODULE (EMD) - P/N RMTI-EMD-HT

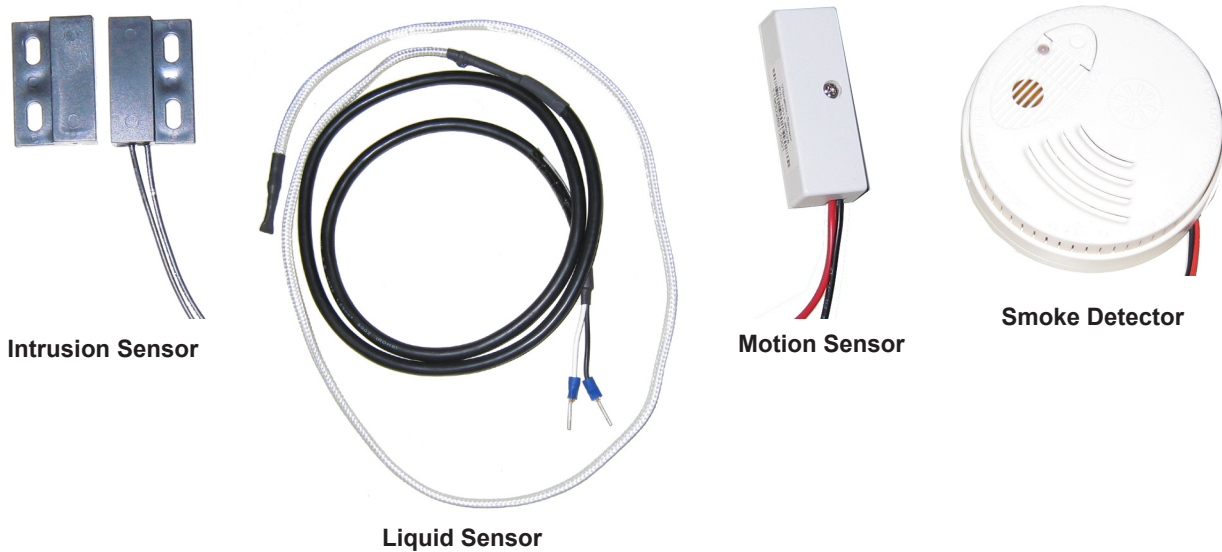


FIGURE 15-5: (OPTIONAL) EMD SENSORS - P/N RMTI-EMD-SENSORS

## 16. UPS Protection System

### 16.1 UPS Protection Devices

The following schematic shows the electrical locations of the protection devices on the UPS.

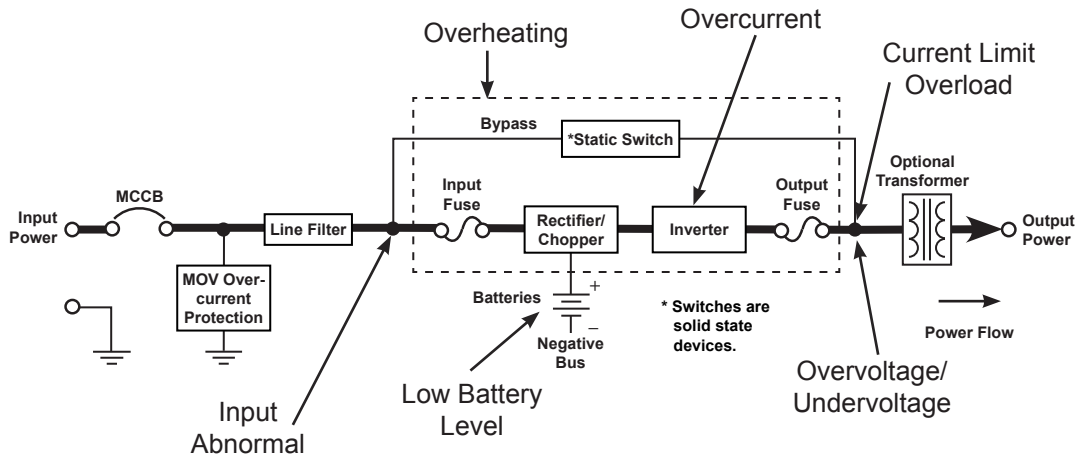


FIGURE 16-1: UPS PROTECTION DEVICE LOCATIONS

### 16.2 UPS Protection Devices Fault Response

The following charts show the UPS response to common faults.

TABLE 16-1: UPS FAULT PROTECTION FUNCTIONS

| Protection Item               | Output Overvoltage   | Output Undervoltage                             | Output Overload  |
|-------------------------------|--|---|--|
| LCD Message                   | <b>VOOV</b>  | <b>VOUV</b>                                     | <b>OL110</b>   |
| Cause                         | Control malfunction;<br>EEPROM error<br>(reprogram or replace) | Control malfunction;<br>Fuse opened; Load issue | Loading that exceeds design<br>parameters  |
| Operation Mode<br>After Fault | Bypass operation – Chopper and inverter are<br>stopped         |   | Inverter OL: Transfer to bypass;<br>Bypass OL: Inverter stopped,<br>chopper continues to boost DC<br>bus |
| Audible Alarm                 | Continuous buzzer  |   | See Audible Alarm Functions on<br>page   |
| Visible Alarm                 | Red Fault LED on   |   | Inverter OL: Fault lamp off<br>Bypass OL: Fault lamp on  |
| Relay Contact<br>Alarm        | Fault relay closed<br>Bypass relay closed                      |   | Fault relay open;<br>Inverter OL: Bypass relay closed<br>Bypass OL: Bypass relay open                    |
| Auto-retransfer*              | No   |   | Inverter OL: Yes if bypass is OK<br>Bypass OL: No  |

**TABLE 16-1: UPS FAULT PROTECTION FUNCTIONS (CONT'D)**

| Protection Item            | Ambient Overheat                                  | DC Circuit Overvoltage  | DC Circuit Overcurrent |
|----------------------------|---|---|------------------------|
| LCD Message                | AOH   | DCOV  | DCOC                   |
| Cause                      | Fan failure;<br>High internal ambient temperature | Chopper malfunction   | Inverter/chopper fault |
| Operation Mode After Fault | Shutdown – No output                              | Bypass operation – Chopper and inverter are stopped<br>Inverter OL – Transfer to bypass |                        |
| Audible Alarm              | Continuous buzzer                                 |   |                        |
| Visible Alarm              | Red Fault LED on                                  |   |                        |
| Relay Contact Alarm        | Fault relay closed<br>Bypass relay closed         |   |                        |
| Auto-retransfer            | No  |   |                        |

UPS will attempt two sequential Auto-retransfers before requiring manual transfer.

### 16.3 System Fault Messages

A Fault message is generated when either a fault condition occurs, or a warning condition occurs three times within ten minutes. The table below shows the possible fault messages and what actions need be taken.

If the input voltage is normal when the fault occurs then the UPS will switch immediately to the bypass mode to continuously feed power to the load.

If the fault condition occurs while the input power is abnormal and the UPS is in Bypass mode, the UPS will shut down the output to prevent load equipment damage.

When a Fault condition exists, the red LED on the UPS display panel will illuminate until the fault is cleared.

All faults except EXTBC1 and EXTBC2 are recorded. The fault status can cleared by cycling UPS power (turn off until the display goes blank, then turn on) after the problem has been fixed.

**TABLE 16-2: UPS FAULT MESSAGES**

| Display | Re-corded | Meaning  | Action   |
|---------|-----------|--|--|
| BYPOH   | Y         | Bypass Overheat – Overheating condition occurred.                                  | Check unit for blocked or in-operable fan. Lower ambient temperature if it is greater than 104 °F (40 °C). Bypass operation will also cease if overheat condition is not corrected within 1 hr. of inverter shutdown. Try restarting. If condition repeats plan for total shutdown and call for service. |
| BYPOL   | Y         | Bypass Overload – UPS is over-loaded.  | Shut down excess equipment to reduce load.   |
| CHRGV   | Y         | Charger Overvoltage – Charger overvoltage condition occurred.                      | UPS is faulty. Check the UPS operation conditions at time of fault. Not advisable to restart the UPS. Call Toshiba for service.  |
| CL      | Y         | Current Limit – Load on UPS output exceeds unit specifications.                    | Reduce load on UPS output.   |
| DCIB    | Y         | DC Bus Imbalance – DC voltage imbalance occurred.                                  | Possible causes of UPS fault are connection of half-wave rectifier load. Check load and try restarting. If condition persists, call Toshiba for service.   |
| DCOC    | Y         | DC Bus Overcurrent – DC overcurrent condition occurred.                            | UPS is faulty. Check the UPS operation conditions at time of fault. Not advisable to restart the UPS. Call Toshiba for service.  |
| DCOV    | Y         | DC Bus Overvoltage – DC overvoltage condition occurred.                            | UPS is faulty, input wiring error, input overvoltage or connection of a motor load. Try restarting. If condition persists call Toshiba for service.  |
| DCUVBS  | Y         | DC Bus Undervoltage during Boostup Mode – DC Bus undervoltage condition occurred.  | UPS is faulty. Check the UPS operation conditions at time of fault. Not advisable to restart the UPS. Call Toshiba for service.  |
| DCUVC   | Y         | DC Bus Undervoltage During Charging Mode – DC Bus undervoltage condition occurred. | UPS is faulty. Check the UPS operation conditions at time of fault. Not advisable to restart the UPS. Call Toshiba for service.  |
| DVCOH   | Y         | Device Overheat – Overheating condition occurred.                                  | Reduce equipment load to 100% or less and try restarting.  |



| Display | Re-corded | Meaning   | Action  |
|---------|-----------|---|---|
| EXTBC1  | N         | 1. BC1 Battery String 1, 2, or 3 Loose HCT Connection<br>2. BC1 Overvoltage Fault<br>3. BC1 Overcurrent Fault | <ul style="list-style-type: none"> <li>• Call Toshiba for Service.</li> <li>• Call Toshiba for Service</li> <li>• Call Toshiba for Service</li> </ul> |
| EXTBC2  | N         | 1. BC2 Battery String 1, 2, or 3 Loose HCT Connection<br>2. BC2 Overvoltage Fault<br>3. BC2 Overcurrent Fault | <ul style="list-style-type: none"> <li>• Call Toshiba for Service.</li> <li>• Call Toshiba for Service</li> <li>• Call Toshiba for Service</li> </ul> |
| FSOPEN  | Y         | Fuse Open.  | Replace fuse.   |
| INVOLNR | Y         | Inverter Overload (Not Resettable) – Output overload condition occurred.                                      | Reduce equipment load to 100% or less and manually restart the UPS.   |
| INVOLR  | Y         | Inverter Overload (Resettable) – Output overload condition occurred.  | Reduce equipment load to 100% or less, the UPS will retransfer.   |
| OOC     | Y         | Output Overcurrent – UPS is overloaded.   | Shut down excess equipment to reduce load.  |
| VOOV    | Y         | Output Overvoltage – Output overvoltage condition occurred.   | UPS is possibly faulty. Check the UPS operation conditions at time of fault. Not advisable to restart the UPS. Call Toshiba for service.              |
| VOUV    | Y         | Output Undervoltage – Output undervoltage condition occurred.   | UPS is possibly faulty. Check the UPS operation conditions at time of fault. Not advisable to restart the UPS. Call Toshiba for service.              |

## 16.4 System Warning Messages

Warning messages are generated when a noncritical abnormal operating condition occurs. The following table shows possible messages and their meaning.

When a Warning condition exists, the amber LED on the UPS display panel will flash for the duration of the Warning condition.

All warnings will clear after the appropriate action has been taken.

**TABLE 16-3: UPS WARNING MESSAGES**

| Display | Re-corded | Meaning   | Action  |
|---------|-----------|---|---|
| AOH     | Y         | Ambient Overheat – The unit is overheated.  | Check to see if the ambient temperature is greater than 104 °F (40 °C) If so, turn on air conditioning and check the ventilation fan at the back of the unit for operation or obstructions. Otherwise, shut down the unit and call Toshiba for service. |
| ASYN    | N         | Asynchronous mode – Input and output frequency are different. Bypass is disabled. | No Action Needed.   |



| Display | Re-corded | Meaning   | Action  |
|---------|-----------|---|---|
| BDEPL   | N         | Battery Depleted – Battery not within specifications.   | Call Toshiba for service.   |
| BLFE    | Y         | Battery Lifetime End – Batteries at end of life.  | Have batteries replaced immediately.  |
| BLFN    | Y         | Battery Lifetime Near End – Batteries are nearing the end of their expected lifetime.   | Call Toshiba for service.   |
| BOH     | Y         | Battery Overheat – Battery not within specifications.   | Call Toshiba for service.   |
| BRPL    | Y         | Replace Battery – Battery at end of life expectancy.  | Replace battery immediately.  |
| BSDV    | N         | Battery Shutdown Voltage – Battery is discharged down to minimum level.   | UPS will shut down. Secure critical loads until power can be restored.  |
| BTSTFL  | N         | Battery Test Failed – Battery not within specifications.  | Call Toshiba for service.   |
| BYPOV   | N         | Bypass Overvoltage – Bypass voltage exceeds UPS specifications. (See NOTE, Page A-1 “Bypass Voltage”)   | UPS in Bypass Mode: UPS turns off bypass power to the load until bypass power returns to normal. Check bypass power.  |
| BYPUV   | N         | Bypass Undervoltage – Bypass voltage less than UPS specifications. (See NOTE, Page A-1 “Bypass Voltage”)  | UPS in Bypass Mode: UPS turns off bypass power to the load until bypass power returns to normal. Check bypass power.  |
| CALL    | Y         | Service Call Required – Inspection of the unit is advised.  | Have inspection/service performed.  |
| CHRGV   | Y         | Charger Overvoltage – Battery Charger not within specifications.  | Call Toshiba for service.   |
| CLMT    | N         | Current Limit – UPS not within specifications.  | Call Toshiba for service.   |
| DCER    | Y         | Display Cable Error – Display cable is disconnected.  | Connect the display cable.  |
| DCANERR | N         | Communication Error between Display and Main Controllers.   | Call Toshiba for service.   |
| EXTBC1  | N         | <ol style="list-style-type: none"> <li>1. BC1 Battery String 1, 2, or 3 Disconnected</li> <li>2. BC1 Over Temperature</li> <li>3. BC1 Lost Communications with UPS</li> </ol> | <ul style="list-style-type: none"> <li>• Recover without power cycle - Must Manually Reset.</li> <li>• Reduce Load on BC, call factory Toshiba for Service</li> <li>• Call Toshiba for Service</li> </ul> |
| EXTBC2  | N         | <ol style="list-style-type: none"> <li>1. BC2 Battery String 1, 2, or 3 Disconnected</li> <li>2. BC2 Over Temperature</li> <li>3. BC2 Lost Communications with UPS</li> </ol> | <ul style="list-style-type: none"> <li>• Recover without power cycle - Must Manually Reset.</li> <li>• Reduce Load on BC, call Toshiba for Service</li> <li>• Call Toshiba for Service</li> </ul>         |

| Display  | Re-corded | Meaning   | Action   |
|----------|-----------|---|--|
| FBYPER   | N         | Bypass Frequency Error – Input frequency outside of UPS specifications.   | UPS in Bypass Mode: UPS turns off bypass power to the load until bypass frequency returns to normal. Check bypass frequency. |
| FIER     | N         | Input Frequency Error – Input frequency outside of 45 – 65 Hz range.  | UPS in Online Mode: UPS switches to BACKUP mode until Input Frequency returns to normal.                                     |
| LB       | N         | Low Battery – The battery level has dropped low (about 90% or less) during operation. Continued operation in this mode will deplete battery and cause output shut down. | Immediately shut down the load equipment in an orderly fashion and then press the STOP key.                                  |
| OL110    | N         | Overload – UPS is overloaded (110% and above) Unit will switch to bypass operation or shut down if no action is taken.  | Shut down excess equipment to reduce load.   |
| REYEERR  | N         | Communication Error between RemotEye and UPS.   | Ensure RemotEye is connected to UPS. Call Toshiba for service.   |
| RS232ERR | N         | Communication Error at Service Port.  | Call Toshiba for service.  |
| REYEUER  | N         | Communication Error at LAN.   | Call Toshiba for service.  |
| VDCUVBT  | N         | DC Bus Undervoltage During Battery Test.  | Call Toshiba for service.  |
| VIOV     | N         | Input Overvoltage – Input voltage exceeds UPS specifications.   | UPS in On-Line Mode: UPS switches to BACKUP mode until Input Voltage returns to normal. Check input power.                   |
| VIUV     | N         | Input Undervoltage – Input voltage less than UPS specifications.  | UPS in On-Line Mode: UPS switches to BACKUP mode until Input Voltage returns to normal. Check input power.                   |

## 16.5 System Mode Messages

A UPS Mode message is generated when the UPS changes operating mode. The following tables list the possible operating modes for the UPS.

**TABLE 16-4: UPS WARNING MESSAGES**

| Display  | Meaning  |
|----------|--|
| Backup   | Backup – Power comes from other than input.                                  |
| BattTest | Battery Test – Battery test in progress.                                     |
| Bypass   | Bypass – UPS is offline, power is being provided directly from UPS input.    |
| On-Line  | On-Line – Input converter and inverter are running (Double conversion mode). |
| Shutdown | Shutdown – No output, DC Bus is charged through Softstart Resistor.          |
| Startup  | Startup – UPS is starting up.  |

## 16.6 System Status Messages

A UPS Status message is generated when the UPS changes its status (e.g. from inverter to bypass mode). The table below shows the possible Status messages and their meaning.

**TABLE 16-5: UPS SYSTEM STATUS MESSAGES**

| Display  | Meaning   | Action  |
|----------|---|---|
| BYP      | Bypass mode – Power is supplied by UPS input.   | No action needed.   |
| CHRGERR  | Charger Error – Charger overvoltage error.  | Call Toshiba for service.   |
| DLYST    | Delay Start – UPS is counting down prior to startup.  | No action needed.   |
| EE1ST    | EEPROM is loaded with default values.   | No action needed.   |
| EE2RAERR | EEPROM to RAM loading Error.  | Call Toshiba for service.   |
| EEUPERR  | EEPROM updating Error.  | Call Toshiba for service.   |
| EPO      | EPO circuit is active.  | Reset EPO switch to start.  |
| FIERRST  | Frequency Input Error Start – Input frequency could not be detected and UPS starts up with default EEPROM setup.  | Ensure correct input frequency is selected in UPS settings.                                 |
| FLT      | A fault has occurred.   | See Fault records.  |
| FWUPERR  | Firmware Update Error.  | Call Toshiba for service.   |
| INIT     | Initialization – UPS is initializing.   | No action needed.   |
| INV      | Inverter mode.  | Inverter is running (it can be On-Line, Battery Test, or Backup)                            |
| LANSD    | UPS goes to Shutdown triggered from customer supplied LAN SD circuit.   | Deactivate LAN shutdown signal to reset.  |
| LB       | Low Battery – The battery level has dropped low (about 90% or less) during operation. Continued operation in this mode will deplete battery and cause output shut down. | Immediately shut down the load equipment in an orderly fashion and then press the STOP key. |
| PFAIL    | Input power failure.  | No action needed.   |
| RMTSD    | Remote shutdown occurred.   | Disconnect LAN signal to reset.   |
| RO2EEERR | ROM to EE Loading Error.  | Call Toshiba for service.   |
| SYNC     | Synchronous mode.   | Input and output are synchronized.  |
| TIMEDSD  | UPS is counting down prior to shutdown.   | Immediately shut down the load equipment in an orderly fashion and then press the STOP key. |
| WRN      | A warning has occurred.   | See Warning record.   |

## 17. Preventive Maintenance/Parts Replacement

### 17.1 Preventive Maintenance

Toshiba T1000 is designed to provide years of trouble-free operation requiring a minimum amount of preventive maintenance.

The best preventive measure that the UPS user can take is to keep the area around the unit, particularly the air inlet vents, clean and free of moisture and dust accumulations. If the atmosphere of the installation site is very dusty, use a vacuum cleaner to periodically remove dust accumulations around and from the unit.



**Only a qualified Toshiba representative should be allowed to perform any routine maintenance or service on this equipment other than those preventive maintenance details which are described directly above this caution.**

### 17.2 LCD Display Cleaning

The LCD display should be cleaned with a clean, damp cotton cloth to avoid scratching the coating.

### 17.3 Battery Replacement

The T1000 comes equipped with internal backup batteries packaged in three sets of 6 batteries per battery pack.

## NOTICE

Ensure the T1000 battery packs are replaced with battery packs of the same part number. Failure to do so may cause unexpected loss of backup power.

### 17.4 Part Replacement

The following list shows recommended intervals for periodic replacement of certain UPS parts:

1. Electrolytic capacitor PC Board: Replace capacitor boards once every 5 years.  
(The electrolytic aluminum capacitors are mounted on a PC Board)
2. Fuses: Replace once every 7 years.
3. Cooling fan: When operated in an ambient temperature of 86 °F (30 °C) to 104 °F (40° C), replace every 3.5 years. When operated in an ambient temperature of less than 86 °F (30 °C) , replace every 5 years.  
NOTE: The cooling fans are not hot swappable. Remove all power from the UPS before replacing the cooling fans.  
(Open the UPS main circuit breaker and disconnect external battery interface cable.)
4. Batteries: In order to maintain system reliability, the UPS batteries should be replaced on a regular schedule. To ensure reliable operation, all of the batteries should be replaced at the same time. Use the following chart for replacement:

**UPS BATTERY REPLACEMENT**

| BATT AMB TEMP*          | AVERAGE LIFETIME        |
|-------------------------|-------------------------|
| 68 – 77 °F (20 – 25 °C) | Approximately 5 yrs.    |
| 86 °F (30 °C)           | Approximately 3.5 yrs.  |
| 95 °F (35 °C)           | Approximately 2.5 yrs.  |
| 104 °F (40 °C)          | Approximately 1.8 yrs.  |
| 113 °F (45 °C)          | Approximately 1.25 yrs. |

\* Continual operation at ambient temperatures above 25 °C will degrade the battery life.

## 18. Shipping Weights/Dimensions

### 18.1 Unit and Shipping Weights

| Unit                                   | Part Number      | Unit Weight <sup>1</sup> |           | Shipping Weight <sup>1</sup> |           |
|--|------------------|--------------------------|-----------|------------------------------|-----------|
|  |                  | Pounds                   | Kilograms | Pounds                       | Kilograms |
| Power Module (Rack) 5.2kVA             | T1P0A5200GXGR3L1 | 63                       | 28.6      | 92                           | 41.7      |
| Power Module (Tower) 5.2kVA            | T1P0A5200GXGL1   | 63                       | 28.6      | 92                           | 41.7      |
| Power Module (Rack) 6kVA               | T1P0A6000GXGR3   | 63                       | 28.6      | 92                           | 41.7      |
| Power Module (Tower) 6kVA              | T1P0A6000GXG     | 63                       | 28.6      | 92                           | 41.7      |
| Battery Module (Rack)                  | T1B06000005R3    | 147                      | 66.7      | 176                          | 79.8      |
| Battery Module (Tower)                 | T1B06000005      | 147                      | 66.7      | 176                          | 79.8      |
| Battery Mod. w/ Panel Option<br>(Rack) | T1B06000005R3Px  | 149                      | 67.7      | 178                          | 80.8      |
| (Tower)                                | T1B06000005Px    | 149                      | 67.7      | 178                          | 80.8      |
| Transformer Module (Rack)              | T1X06000GA-N1-R3 | 76                       | 34.5      | 105                          | 47.6      |
| Transformer Module (Tower)             | T1X06000GA-N1    | 76                       | 34.5      | 105                          | 47.6      |

1. Subject to change without notice.

### 18.2 Shipping Dimensions

All modules are individually palletized. The module/pallet assembly measurement are shown in the table below:

| Shipping Dimensions                  |                      |                    |                       |
|--------------------------------------|----------------------|--------------------|-----------------------|
|                                      | Height               | Width              | Depth                 |
| Palletized Module<br>(5.2 & 6 kVA)   | 16.5 in.<br>(491 mm) | 24 in.<br>(610 mm) | 34 in.<br>(864 mm)    |
| Module packaging<br>(without pallet) | 11 in.<br>(279 mm)   | 23 in.<br>(584 mm) | 32.75 in.<br>(832 mm) |

This page intentionally left blank

## Appendix A: Specifications

### A.1 T1000 POWER MODULE - 6kVA

NOTE: Except for size, weight, and Part Number, the Rackmount and Tower specifications are the same.

| T1000 6 KVA SPECIFICATIONS - POWER MODULE        |  |
|--|--|
| Parameter  | Value  |
| <b>GENERAL</b>                                   |  |
| Model No.  | Tower T1P0A6000GXG<br>Tower with Line Cord T1P0A6000GXGL1<br>Rackmount T1P0A6000GXGR3<br>Rackmount with Line Cord T1P0A6000GXGR3L1   |
| Capacity Output                                  | 6 kVA  |
| Topology   | True Online, Double conversion, IGBT Power Factor Correction Input   |
| <b>INPUT</b>                                     |  |
| Voltage (V)                                      | Single Phase - 208/240 Vin +10% to -15% (L to L)*<br>(Adjustable to +10/-10%, or +15/-20%; set on front panel)<br>(*NOTE: Down to Vin -30% @ 70% Load)   |
| Current (Nominal) (A)                            | 25 A @ 240 V (30 A @ 208 V)  |
| Current (Max) @ 208 V (A)                        | 32 A   |
| Current (Max) @ 240 V (A)                        | 25 A (32 A @ 85% of 240 V)   |
| Current (Min.) No-Load @ 240 V (A)               | 8 A (Typical)  |
| Current, Peak Inrush (A)                         | 20 A Peak (Typical)  |
| Current Limit (%)                                | 125%   |
| Current THD (%)                                  | < 5%   |
| Frequency (Hz) [and range]                       | 45-65 Hz auto sensing ± 3 Hz   |
| Input Power Factor (PF) @ full load              | Greater than 0.97  |
| Startup Delay (sec)                              | Default: 0 sec (Range: 0 – 800 sec in 1 sec increments)  |
| Ground leakage (max.) (mA)                       | 5 mA (UPS only)  |
| Internal AC Input Breaker Rating                 | 50 A, 240 V  |
| Surge Protection (kA or Category)                | MOV 250 Joules on Input  |
| <b>BYPASS</b>                                    |  |
| Voltage (V) (selectable)                         | Set by display panel : +10/-15% of nominal (default);<br>+10/-10% of nominal<br>+15/-20% of nominal<br><br><i>NOTE: The Display software cannot make floating point (decimal) calculations. There may be differences between the nominal and calculated BYPOV and BYPUV.<br/>Example: BYPOV set to 115%, at 208V that should be 239.2V. The decimal value .2 will be truncated (cut off) and the value 239V will be sent to the control board. This will be read back to the display as 114% (114.9% truncates to 114%).</i> |
| Bypass Overload @ 125% Load (min)                | 10 min.  |
| Bypass Overload @ 1000% Load                     | 1 cycle  |
| Bypass Disable                                   | Automatic (when Input and Output Voltage/Frequency are set to different values)  |
| Automatic Retransfer (Max load % for Retransfer) | 4 ms (1/4 cycle) at <105% Max Load   |

| <b>T1000 6 KVA SPECIFICATIONS - POWER MODULE</b>                 |  |
|--|--|
| <b>Parameter</b>   | <b>Value</b>   |
| Max. Automatic Retransfer Attempts                               | 2  |
| Online Transfer Time – Inverter to Bypass and Bypass to Inverter | Less than 4 ms   |
| <b>OUTPUT</b>  |  |
| Voltage (V)  | 200 / 208 / 220 / 230 / 240 V (L-L) and Option with transformer for 120 V (L-N)  |
| Voltage Regulation - Online Mode (%)                             | ± 3%   |
| Voltage Regulation - Battery Mode (%)                            | ±3% Vrms for entire battery voltage range and 0 to 100% load   |
| Wave Form  | Sine wave, zero transfer time  |
| Voltage Total Harmonic Distortion (Linear Full Load) (%)         | Less than 3 % THD  |
| Voltage Total Harmonic Distortion (Non-Linear Full Load) (%)     | Less than 5 % THD  |
| Output Voltage Adjustment (V)                                    | ±10 V in 1 V increments  |
| Voltage Transient Response (%) @ 0%-100% Step Load Change        | ± 8 % max.   |
| Voltage Transient Response (%) @ 100%-0%-100% Load Change        | ± 8 % max.   |
| Voltage Transient Recovery with R Load (Recovery to 1% in x ms)  | To +/- 1% of nominal voltage within 30 ms  |
| Common-mode Noise (dB)   | less than 0.5 Vrms   |
| Current (A)  | 25 A (Current limited to 25 A regardless of selected output voltage)   |
| Max Overload Current (continuous) (A)                            | 25 A   |
| Crest Factor   | 3.0 at full load   |
| Leakage Current to Ground (mA)                                   | 5 mA   |
| Inrush Current Protection  | via Soft Start (Charge) Circuit  |
| Frequency (Hz)   | 50 / 60 Hz auto sensing  |
| Frequency Selectable (Converter)                                 | Yes - 50/60 Hz   |
| Frequency Regulation (%) Free Running Mode                       | ± 0.25 Hz  |
| Frequency Sync Range (Hz)  | ± 3 Hz selectable in 0.1 Hz increments (± 1 Hz default)  |
| Slew Rate (Hz/sec)   | ± 3 Hz/sec selectable in 0.1 Hz/sec increments (± 1 Hz/sec default)  |
| Output Power Factor (PF)   | 0.9 at rated voltage and current<br>(1.0 allowed if output current ≤ 25 A and output power is ≤ 5400 W)<br>(Min. 0.4 PF Lagging) |
| Inverter Overload Capacity (% for sec)                           | 125% for 1 min., 150% for 10 sec.  |
| Efficiency AC-DC-AC (240V) (%)                                   | 87% (Typical)  |
| Efficiency AC-DC-AC (120V w/ Transformer Module) (%)             | 84% (Typical)  |
| Unloaded Power Consumption                                       | 479 W  |



| <b>T1000 6 KVA SPECIFICATIONS - POWER MODULE</b>    |  |
|---|--|
| <b>Parameter</b>                                    | <b>Value</b>   |
| Short Circuit Protection                            | Electronic and Hardware Overload Protection  |
| Cold Start (0-100% load)                            | Default Output Frequency 60 Hz   |
| <b>Battery General, External</b>                    |  |
| Acceptable Mfgr.                                    | Yuasa Taiwan only  |
| Type  | ~9 AH/12 V Valve Regulated Lead Acid, Flame Retardant  |
|   | Access to batteries requires use of only Phillips head screwdriver   |
| Voltage - Nominal (Vdc)                             | 216 Vdc  |
| Voltage - Minimum (Vdc)                             | 170 Vdc  |
| Voltage -Float (Vdc)                                | 245 Vdc  |
| Max Recharge Current - (Adc)                        | 1.3 A  |
| Recharge Time (Max.)                                | 4 hours to 90%<br>24 hours to 100%   |
|   | Maintains proper float voltage per battery specification over a temperature range of 10 to 40 degree C (2.3 V/cell at 25 degree C with a temperature coefficient of minus 5 millivolts per degree C) |
| Max Discharge Current - (Adc)                       | 40 Adc (Typical)   |
| Battery Level @ Shutdown                            | 1.67 VPC, ± 3% of battery voltage at FL with level automatically raised for lighter loads  |
| Ripple Current (Max.) (% of Full Load Current)      | 15%  |
| Battery Leakage to Ground (mA)                      | 100 mA maximum   |
| Battery Capacity Required at Full Load (W Battery)  | 6505 WB at nominal Bus Voltage<br>(6826 WB at shutdown)  |
| Battery Test (Interval per hr)                      | Automatic and Manual   |
| Battery Low Alarm                                   | ~90% of full 216 V Battery Charge  |
| Battery Protection                                  | Fuse   |
| Overvoltage Protection                              | 2.50 VPC, ± 3% of battery voltage  |
| Protection against Batteries Deep Discharge         | Adjustable SDN (Shutdown) level  |
| Backup Time @ Full Load (Typical)                   | 1 Battery Module - 5 min. 2 battery Modules - 10 min.<br>(Typical: 1 Battery Module - 8 min. 2 battery Modules - 16 min.)  |
| Efficiency DC-AC (%)                                | 85% (Typical)  |
| <b>BATTERY - INTERNAL</b>                           |  |
| Internal Back-up Time at Full Load (at 25 °C) (min) | 5 min.   |
| Type / Rating (Ah)                                  | 12 Vdc, ~9 Ahr   |
| Number of Batteries                                 | 6 Batteries per tray, 3 trays per Battery Module   |
| Replaceable Batteries                               | Yes  |
| <b>ENVIRONMENT</b>                                  |  |
| Cooling   | Forced Air   |
| Operating Temperature (°F/°C)                       | 0 - 40°C (32 - 104°F)  |

| <b>T1000 6 KVA SPECIFICATIONS - POWER MODULE</b> |   |
|--|---|
| <b>Parameter</b>                                 | <b>Value</b>  |
| Storage Temperature (°F/°C)                      | -20 - 40°C (-4 - 104°F)   |
| Operating Humidity (%)                           | 30-90% (Non-Condensing)   |
| Altitude (ft./m)                                 | 3280 ft. (1000 m) above sea level<br>Derate output 5% for each additional 3280 ft. (1000 m) elevation.  |
| Acoustical Noise (dBA)                           | 50 dB(A) maximum at 1 meter from Front Panel (Typical)  |
| Location   | Indoors, away from excessive heat, dust, and moisture.  |
| Heat Rejection (BTU/Hour) @ 240 V                | 2753 BTU/Hr. (typical)  |
| <b>MECHANICAL</b>                                |   |
| Cable Access                                     | Rear  |
| Line Cord (Input) (Optional)                     | Option - Factory-installed 3-conductor #10 SO cord with 6-50P plug  |
| Receptacles                                      | Standard: Terminal Block with J-Box and one (1) L6-30R receptacle<br>Option: Mount two (2) L6-30R receptacles   |
| Weight lb./(kg)                                  | 63 lb. (28.6 kg)  |
| Dimensions - Rackmount WxDxH in (mm)             | w/o Side Supp. Tab: 16.73 in x 24.38 in x 5.22 in<br>(425 mm x 619 mm x 133 mm)<br>w/ Side Supp. Tab: 19.03 in x 24.38 in x 5.22 in<br>(483 mm x 619 mm x 133 mm) |
| Dimensions - Tower WxDxH in (mm)                 | Standard: 5.22 in x 24.38 in x 16.73 in<br>(133 mm x 619 mm x 425 mm)<br>Caster Option: 5.22 in x 29.29 in x 17.48 in<br>(133 mm x 744 mm x 444 mm)               |
| Clearance - Rackmount (in/mm)                    | Front - 32 in., Rear - N/A in.,<br>Top/Bottom - N/A in., Sides N/A  |
| Clearance - Tower (in/mm)                        | Front - 32 in., Rear - 4 in.,<br>Sides/Top - 4 in., Bottom N/A  |
| Enclosure  | Unit enclosure made from sheet metal meeting NEMA 1 and UL Type 1 Standard  |
| Color  | O'Brien Black   |
| Emergency Power Off (EPO)                        | Back Panel (Remote Only)  |
| Control Panel                                    | T1000 Series Panel  |
| <b>MONITORING</b>                                |   |
| Operator Interface (Front Panel)                 | T1000 Series Panel  |
| Dry Contacts Included                            | Accessible via DB9 receptacle on back of Power Module   |
| USB  | via mini-USB adapter  |
| Optional - Intelligent Monitoring                | RemotEye® Option card Slot (Network and RS-485)   |
| <b>ADDITIONAL FEATURES</b>                       |   |
| Optional - Line Cord                             | Option - Terminal Block with 3-conductor SO cord with L6-50P Plug   |
| Receptacles                                      | Standard: Terminal Block with J-Box and one (1) L6-30R receptacle<br>Option: Mount two (2) L6-30R receptacles   |
| External Connectors                              | EPO, USB, Remote Stop   |

| T1000 6 KVA SPECIFICATIONS - POWER MODULE |   |
|---|---|
| Parameter                                 | Value   |
| Rackmount Hardware (Standard)             | All Rackmount modules come standard with the 4-Post Mounting Kit, P/N 92802.                                      |
| Rail Kit (Optional)                       | Optional Rails Kits available with Rack-mount Models  |
| <b>Mounting Kits</b>                      | <b>(Each system configuration requires one of the following kits for each module)</b>                             |
| Tower - 3 Module Systems                  | P/N 93178: One per system   |
| Tower - Caster Kit (Optional)             | P/N 92508: One per module   |
| Rackmount - 2-Post fixed                  | P/N 92801: One per module   |
| Rackmount - 4-Post fixed                  | P/N 92802: One per module (Included)  |
| Rackmount - 2-Post w/ slides              | P/N 90399: One per module   |
| Rackmount - 4-Post w/ slides              | P/N 92800: One per module   |
| <b>OTHER</b>                              |   |
| Warranty (yr.)                            | Three years on electronics, Two years full replacement on battery (See Toshiba warranty policy for full details.) |
| Certifications                            | UL 1778, FCC Class A Part 15,   |

1. Input/output figures rated for 240 volts unless otherwise stated. Output ratings given for 0.9PF are only valid when the input voltage is greater than 204 volts; otherwise, ratings given for 0.70PF are applicable.
2. Battery backup time may vary depending on the operating conditions and ambient temperature at the installation site.
3. An initial charge time of 24 hrs. is necessary to obtain proper battery performance level before unit is placed in operation.
4. If Vin is below the minimum Vin window, the UPS goes to Battery Mode. If the UPS is in Fault and Vin is below the minimum Vin window, the UPS goes to Bypass Mode

| T1000 6KVA EFFICIENCY AT % OF FULL LOAD <sup>1</sup> |         |       |       |      |      |
|--|---------|-------|-------|------|------|
| (1.0 PF @ 240 V)                                     | No Load | 25%   | 50%   | 75%  | 100% |
| Efficiency (AC-AC)                                   | (479 W) | 78.5% | 85.6% | 87%  | 87%  |
| Thermal Load (BTU/hr)                                | 1634    | 1262  | 1550  | 2065 | 2753 |

1. Typical efficiency values. Individual results may vary.

| T1000 BATTERY MODULE TYPICAL BACKUP TIME AT DIFFERENT LOADS |     |     |     |     |     |     |      |     |     |      |
|---|-----|-----|-----|-----|-----|-----|------|-----|-----|------|
| Estimated* Backup time in minutes at % full load @ 0.9 PF   |     |     |     |     |     |     |      |     |     |      |
| # of T1B-6000xxx  | 10% | 20% | 30% | 40% | 50% | 60% | 70%  | 80% | 90% | 100% |
| 1 Battery Module  | >60 | >60 | 42  | 28  | 20  | 16  | 12.5 | 10  | 8.5 | 5    |
| 2 Battery Modules   | >60 | >60 | >60 | >60 | 50  | 42  | 34   | 28  | 24  | 20   |

\* Backup times are estimates only. Actual time will vary due to manufacturing variances, age of batteries, duty cycle, etc.

## A.2 T1000 POWER MODULE - 5.2kVA

NOTE: Except for size, weight, and Part Number, the Rackmount and Tower specifications are the same.

| T1000 5.2 KVA SPECIFICATIONS - POWER MODULE                      |  |
|--|--|
| Parameter  | Value  |
| <b>GENERAL</b>   |  |
| Model No. Tower with Line Cord                                   | T1P0A5200GXGL1   |
| Rackmount with Line Cord:  | T1P0A5200GXGR3L1   |
| Capacity Output  | 5.2 kVA  |
| Topology   | True Online, Double conversion, IGBT Power Factor Correction Input   |
| <b>INPUT</b>   |  |
| Voltage (V)  | Single Phase - 208/240 Vin +10% to -15% (L to L)*<br>(Adjustable to +10/-10%, or +15/-20%; set on front panel)<br>(*NOTE: Down to Vin -30% @ 70% Load)   |
| Current (Nominal) (A)  | 21.6 A @ 240 V (26 A @ 208 V)  |
| Current (Max) @ 208 V (A)  | 27.7 A   |
| Current (Max) @ 240 V (A)  | 21.6 A (26 A @ 85% of 240 V)   |
| Current (Min.) No-Load @ 240 V (A)                               | 8 A (Typical)  |
| Current, Peak Inrush (A)   | 20 A Peak (Typical)  |
| Current Limit (%)  | 125%   |
| Current THD (%)  | < 5%   |
| Frequency (Hz) [and range]                                       | 45-65 Hz auto sensing ± 3 Hz   |
| Input Power Factor (PF) @ full load                              | Greater than 0.97  |
| Startup Delay (sec)  | Default: 0 sec (Range: 0 – 800 sec in 1 sec increments)  |
| Ground leakage (max.) (mA)                                       | 5 mA (UPS only)  |
| Internal AC Input Breaker Rating                                 | 30 A, 240 V  |
| Surge Protection (kA or Category)                                | MOV 250 Joules on Input  |
| <b>BYPASS</b>  |  |
| Voltage (V) (selectable)   | Set by display panel : +10/-15% of nominal (default);<br>+10/-10% of nominal<br>+15/-20% of nominal<br><br><i>NOTE: The Display software cannot make floating point (decimal) calculations. There may be differences between the nominal and calculated BYPOV and BYPUV.<br/>Example: BYPOV set to 115%, at 208V that should be 239.2V. The decimal value .2 will be truncated (cut off) and the value 239V will be sent to the control board. This will be read back to the display as 114% (114.9% truncates to 114%).</i> |
| Bypass Overload @ 125% Load (min)                                | 10 min.  |
| Bypass Overload @ 1000% Load                                     | 1 cycle  |
| Bypass Disable   | Automatic (when Input and Output Voltage/Frequency are set to different values)  |
| Automatic Retransfer (Max load % for Retransfer)                 | 4 ms (1/4 cycle) at <105% Max Load   |
| Max. Automatic Retransfer Attempts                               | 2  |
| Online Transfer Time – Inverter to Bypass and Bypass to Inverter | Less than 4 ms   |

| <b>T1000 5.2 KVA SPECIFICATIONS - POWER MODULE</b>              |   |
|---|---|
| <b>Parameter</b>  | <b>Value</b>  |
| <b>OUTPUT</b>   |   |
| Voltage (V)   | 200 / 208 / 220 / 230 / 240 V (L-L) and<br>Option with transformer for 120 V (L-N)  |
| Voltage Regulation - Online Mode (%)                            | ± 3%  |
| Voltage Regulation - Battery Mode (%)                           | ±3% Vrms for entire battery voltage range and 0 to 100% load  |
| Wave Form   | Sine wave, zero transfer time   |
| Voltage Total Harmonic Distortion (Linear Full Load) (%)        | Less than 3 % THD   |
| Voltage Total Harmonic Distortion (Non-Linear Full Load) (%)    | Less than 5 % THD   |
| Output Voltage Adjustment (V)                                   | ±10 V in 1 V increments   |
| Voltage Transient Response (%)<br>@ 0%-100% Step Load Change    | ± 8 % max.  |
| Voltage Transient Response (%)<br>@ 100%-0%-100% Load Change    | ± 8 % max.  |
| Voltage Transient Recovery with R Load (Recovery to 1% in x ms) | To +/- 1% of nominal voltage within 30 ms   |
| Common-mode Noise (dB)  | less than 0.5 Vrms  |
| Current (A)   | 21.67 A<br>(Current limited to 21.67A regardless of selected output voltage)  |
| Max Overload Current (continuous) (A)                           | 21.6 A  |
| Crest Factor  | 3.0 at full load  |
| Leakage Current to Ground (mA)                                  | 5 mA  |
| Inrush Current Protection                                       | via Soft Start (Charge) Circuit   |
| Frequency (Hz)  | 50 / 60 Hz auto sensing   |
| Frequency Selectable (Converter)                                | Yes - 50/60 Hz  |
| Frequency Regulation (%)<br>Free Running Mode                   | ± 0.25 Hz   |
| Frequency Sync Range (Hz)                                       | ± 3 Hz selectable in 0.1 Hz increments (± 1 Hz default)   |
| Slew Rate (Hz/sec)  | ± 3 Hz/sec selectable in 0.1 Hz/sec increments (± 1 Hz/sec default)   |
| Output Power Factor (PF)  | 0.9 at rated voltage and current (1.0 allowed if output current ≤ 21.67 A and output power is ≤ 4507 W) (Min. 0.4 PF Lagging) |
| Inverter Overload Capacity (% for sec)                          | 125% for 1 min., 150% for 10 sec.   |
| Efficiency AC-DC-AC (240V) (%)                                  | 87% (Typical)   |
| Efficiency AC-DC-AC (120V w/<br>Transformer Module) (%)         | 84% (Typical)   |
| Unloaded Power Consumption                                      | 479 W   |
| Short Circuit Protection  | Electronic and Hardware Overload Protection   |
| Cold Start (0-100% load)  | Default Output Frequency 60 Hz  |

| <b>T1000 5.2 KVA SPECIFICATIONS - POWER MODULE</b>  |  |
|---|--|
| <b>Parameter</b>                                    | <b>Value</b>   |
| <b>Battery General, External</b>                    |  |
| Acceptable Mfgr.                                    | Yuasa Taiwan only  |
| Type  | ~9 AH/12 V Valve Regulated Lead Acid, Flame Retardant  |
|   | Access to batteries requires use of only Phillips head screwdriver   |
| Voltage - Nominal (Vdc)                             | 216 Vdc  |
| Voltage - Minimum (Vdc)                             | 170 Vdc  |
| Voltage -Float (Vdc)                                | 245 Vdc  |
| Max Recharge Current - (Adc)                        | 1.3 A  |
| Recharge Time (Max.)                                | 4 hours to 90%<br>24 hours to 100%   |
|   | Maintains proper float voltage per battery specification over a temperature range of 10 to 40 degree C (2.3 V/cell at 25 degree C with a temperature coefficient of minus 5 millivolts per degree C) |
| Max Discharge Current - (Adc)                       | 34.6 Adc (Typical)   |
| Battery Level @ Shutdown                            | 1.67 VPC, ± 3% of battery voltage at FL with level automatically raised for lighter loads  |
| Ripple Current (Max.) (% of Full Load Current)      | 15%  |
| Battery Leakage to Ground (mA)                      | 100 mA maximum   |
| Battery Capacity Required at Full Load (W Battery)  | 5637 WB at nominal Bus Voltage<br>(5916 WB at shutdown)  |
| Battery Test (Interval per hr)                      | Automatic and Manual   |
| Battery Low Alarm                                   | ~90% of full 216 V Battery Charge  |
| Battery Protection                                  | Fuse   |
| Overvoltage Protection                              | 2.50 VPC, ± 3% of battery voltage  |
| Protection against Batteries Deep Discharge         | Adjustable SDN (Shutdown) level  |
| Backup Time @ Full Load (Typical)                   | 1 Battery Module - 5 min. 2 battery Modules - 10 min.<br>(Typical: 1 Battery Module - 8 min. 2 battery Modules - 16 min.)  |
| Efficiency DC-AC (%)                                | 85% (Typical)  |
| <b>BATTERY - INTERNAL</b>                           |  |
| Internal Back-up Time at Full Load (at 25 °C) (min) | 5 min.   |
| Type / Rating (Ah)                                  | 12 Vdc, ~9 Ahr   |
| Number of Batteries                                 | 6 Batteries per tray, 3 trays per Battery Module   |
| Replaceable Batteries                               | Yes  |
| <b>ENVIRONMENT</b>                                  |  |
| Cooling   | Forced Air   |
| Operating Temperature (°F/°C)                       | 0 - 40°C (32 - 104°F)  |
| Storage Temperature (°F/°C)                         | -20 - 40°C (-4 - 104°F)  |
| Operating Humidity (%)                              | 30-90% (Non-Condensing)  |

| <b>T1000 5.2 KVA SPECIFICATIONS - POWER MODULE</b> |   |
|--|---|
| <b>Parameter</b>                                   | <b>Value</b>  |
| Altitude (ft./m)                                   | 3280 ft. (1000 m) above sea level<br>Derate output 5% for each additional 3280 ft. (1000 m) elevation.  |
| Acoustical Noise (dBA)                             | 50 dB(A) maximum at 1 meter from Front Panel (Typical)  |
| Location   | Indoors, away from excessive heat, dust, and moisture.  |
| Heat Rejection (BTU/Hour) @ 240 V                  | 2753 BTU/Hr. (typical)  |
| <b>MECHANICAL</b>                                  |   |
| Cable Access                                       | Rear  |
| Line Cord (Input)                                  | Factory-installed 3-conductor #10 AWG SO cord with L6-30P plug  |
| Receptacles  | Standard: Terminal Block with J-Box and one (1) L6-30R receptacle<br>Option: Mount two (2) L6-30R receptacles   |
| Weight lb./(kg)                                    | 63 lb. (28.6 kg)  |
| Dimensions - Rackmount WxDxH in (mm)               | w/o Side Supp. Tab: 16.73 in x 24.38 in x 5.22 in<br>(425 mm x 619 mm x 133 mm)<br>w/ Side Supp. Tab: 19.03 in x 24.38 in x 5.22 in<br>(483 mm x 619 mm x 133 mm) |
| Dimensions - Tower WxDxH in (mm)                   | Standard: 5.22 in x 24.38 in x 16.73 in<br>(133 mm x 619 mm x 425 mm)<br>Caster Option: 5.22 in x 29.29 in x 17.48 in<br>(133 mm x 744 mm x 4445 mm)              |
| Clearance - Rackmount (in/mm)                      | Front - 32 in., Rear - N/A in.,<br>Top/Bottom - N/A in., Sides N/A  |
| Clearance - Tower (in/mm)                          | Front - 32 in., Rear - 4 in.,<br>Sides/Top - 4 in., Bottom N/A  |
| Enclosure  | Unit enclosure made from sheet metal meeting NEMA 1 and UL Type 1 Standard  |
| Color  | O'Brien Black   |
| Emergency Power Off (EPO)                          | Back Panel (Remote Only)  |
| Control Panel                                      | T1000 Series Panel  |
| <b>MONITORING</b>                                  |   |
| Operator Interface (Front Panel)                   | T1000 Series Panel  |
| Dry Contacts Included                              | Accessible via DB9 receptacle on back of Power Module   |
| USB  | via mini-USB adapter  |
| Optional - Intelligent Monitoring                  | RemotEye® Option card Slot (Network and RS-485)   |
| <b>ADDITIONAL FEATURES</b>                         |   |
| Receptacles  | Standard: Terminal Block with J-Box and one (1) L6-30R receptacle<br>Option: Mount two (2) L6-30R receptacles   |
| External Connectors                                | EPO, USB, Remote Stop   |
| Rackmount Hardware (Standard)                      | All Rackmount modules come standard with the 4-Post Mounting Kit, P/N 92802.  |
| Rail Kit (Optional)                                | Optional Rails Kits available with Rack-mount Models  |
| <b>Mounting Kits</b>                               | <b>(Each system configuration requires one of the following kits for each module)</b>   |



| T1000 5.2 KVA SPECIFICATIONS - POWER MODULE |   |
|---|---|
| Parameter                                   | Value   |
| Tower - 3 Module Systems                    | P/N 93178: One per system   |
| Tower - Caster Kit (Optional)               | P/N 92508: One per module   |
| Rackmount - 2-Post fixed                    | P/N 92801: One per module   |
| Rackmount - 4-Post fixed                    | P/N 92802: One per module (Included)  |
| Rackmount - 2-Post w/ slides                | P/N 90399: One per module   |
| Rackmount - 4-Post w/ slides                | P/N 92800: One per module   |
| <b>OTHER</b>                                |   |
| Warranty (yr.)                              | Three years on electronics, Two years full replacement on battery (See Toshiba warranty policy for full details.) |
| Certifications                              | UL 1778, FCC Class A Part 15,   |

1. Input/output figures rated for 240 volts unless otherwise stated. Output ratings given for 0.9PF are only valid when the input voltage is greater than 204 volts; otherwise, ratings given for 0.70PF are applicable.
2. Battery backup time may vary depending on the operating conditions and ambient temperature at the installation site.
3. An initial charge time of 24 hrs. is necessary to obtain proper battery performance level before unit is placed in operation.
4. If Vin is below the minimum Vin window, the UPS goes to Battery Mode. If the UPS is in Fault and Vin is below the minimum Vin window, the UPS goes to Bypass Mode

| T1000 6KVA EFFICIENCY AT % OF FULL LOAD <sup>1</sup> |         |       |       |      |      |
|--|---------|-------|-------|------|------|
| (1.0 PF @ 240 V)                                     | No Load | 25%   | 50%   | 75%  | 100% |
| Efficiency (AC-AC)                                   | (479 W) | 78.5% | 85.6% | 87%  | 87%  |
| Thermal Load (BTU/hr)                                | 1634    | 1262  | 1550  | 2065 | 2753 |

1. Typical efficiency values. Individual results may vary.

| T1000 BATTERY MODULE TYPICAL BACKUP TIME AT DIFFERENT LOADS |     |     |     |     |     |     |      |     |     |      |
|---|-----|-----|-----|-----|-----|-----|------|-----|-----|------|
| Estimated* Backup time in minutes at % 6kVA @ 0.9 PF        |     |     |     |     |     |     |      |     |     |      |
| # of T1B-6000xxx  | 10% | 20% | 30% | 40% | 50% | 60% | 70%  | 80% | 90% | 100% |
| 1 Battery Module  | >60 | >60 | 42  | 28  | 20  | 16  | 12.5 | 10  | 8.5 | 5    |
| 2 Battery Modules   | >60 | >60 | >60 | >60 | 50  | 42  | 34   | 28  | 24  | 20   |

\* Backup times are estimates only. Actual time will vary due to manufacturing variances, age of batteries, duty cycle, etc.



### A.3 T1000 BATTERY MODULE

Compatible with both the 5.2kVA and 6kVA Power Modules.

| T1000 BATTERY MODULE SPECIFICATIONS                         |   |
|---|---|
| Parameter   | Value   |
| <b>GENERAL</b>  |   |
| Model Number: Rackmount                                     | T1B06000005R3   |
| w/ P1 Receptacle Panel                                      | T1B06000005R3P1 (4 x IEC C13 & 4 x IEC C19)   |
| w/ P2 Receptacle Panel                                      | T1B06000005R3P2 (2 x NEMA L6-20R and 1 x NEMA L6-30R)   |
| Tower   | T1B06000005   |
| w/ P1 Receptacle Panel                                      | T1B06000005P1 (4 x IEC C13 & 4 x IEC C19)   |
| w/ P2 Receptacle Panel                                      | T1B06000005P2 (2 x NEMA L6-20R and 1 x NEMA L6-30R)   |
| DC Output Voltage (V)                                       | 216 VDC   |
| Discharge Current (Nominal) (A)                             | 30 A  |
| Discharge Current (Max.) (A)                                | 40 A  |
| <b>BATTERY - INTERNAL</b>                                   |   |
| Internal Back-up Time at Full Load (at 25 °C) (min.)        | 5 min.  |
| Type / Rating (Ah)  | YUASA REW45-12FR / 8 Ah or YUASA NPX-L35/250FR / 9 Ah   |
| Number of Batteries   | 18 (6 batteries per tray, 3 trays per Battery Module)   |
| Number of Strings   | 1   |
| Max. Recharge (A)   | 1 A (Typical)   |
| <b>MECHANICAL</b>   |   |
| Cable Access  | Rear  |
| Line Cord (Input)   | Dual Anderson receptacles   |
| Output Receptacle Panels (Optional) (Receptacle and Rating) | Optional Output Receptacle Panel:<br>91425: 4 ea. C-13 (250 V, 10 A) & 4 ea. C-19 (250 V, 15 A)<br>91427: 2 ea. L6-20R (250 V, 20 A) & 1 ea. L6-30R (250 V, 30 A) |
| Output Receptacle Panels (Optional) (Receptacle Fusing)     | 91425: C-13 2 x (250 V, 10 A) & C-19 2 x (250 V, 15 A)<br>91427: L6-20R 1 x (250 V, 20 A) & L6-30R 1 x (250 V, 30 A)  |
| Weight lb./(kg)   | 147 lb. (66.7 kg)   |
| Dimensions - Rackmount WxDxH in (mm)                        | w/o Side Supp. Tab: 16.73 in x 24.38 in x 5.22 in<br>(425 mm x 619 mm x 133 mm)<br>w/ Side Supp. Tab: 19.03 in x 24.38 in x 5.22 in<br>(483 mm x 619 mm x 133 mm) |
| Dimensions - Tower WxDxH in (mm)                            | Standard: 5.22 in x 24.38 in x 16.73 in<br>(133 mm x 619 mm x 425 mm)<br>Caster Option: 5.22 in x 29.29 in x 17.48 in<br>(133 mm x 744 mm x 444.5 mm)             |
| Clearance - Rackmount (in/mm)                               | Front - 32 in, Rear - N/A in,<br>Top/Bottom - 0 in., Sides N/A  |
| Clearance - Tower (in/mm)                                   | Front - 32 in, Rear - 4 in,<br>Sides/Top - 0 in., Bottom N/A  |
| Enclosure   | Enclosure of unit made from sheet metal, meets NEMA 1 and UL Type 1 Standard  |
| Construction  | Unit enclosure made from sheet metal meeting NEMA 1 and UL Type 1 Standard  |

## A.4 T1000 TRANSFORMER MODULE

Compatible with both the 5.2kVA and 6kVA Power Modules.

| T1000 TRANSFORMER MODULE SPECIFICATIONS |   |
|---|---|
| Parameter                               | Value   |
| <b>GENERAL</b>                          |   |
| Model Number:                           | Rackmount<br>Tower<br>T1X06000GA-N1-R3<br>T1X06000GA-N1   |
| Capacity Output                         | 6kVA  |
| Topology                                | applies an autotransformer to Power Module output   |
| <b>INPUT</b>                            |   |
| Voltage (V)                             | Single Phase - Either 240 V or 208 V (L to L, or L to N)  |
| Current (Nominal) (A)                   | 25 A  |
| Current (Max) (A)                       | 26 A  |
| <b>OUTPUT</b>                           |   |
| Voltage (V)                             | Single Phase - 120 Vout (L to L)  |
| Current (Nominal) (A)                   | 50 A  |
| Current (Max) (A)                       | Fused to 20 A max to any one receptacle,<br>50 A total across all four receptacles<br><i>(Note: North American plugs with 2 vertical blades are limited to 15 A max,<br/>while plugs with one vertical and one horizontal blade are limited to 20A)</i> |
| <b>MECHANICAL</b>                       |   |
| Cable Access                            | Rear  |
| Input                                   | Anderson connectors from Power Module   |
| Receptacles                             | 4 x 5-20R Duplex Output Receptacles   |
| Weight lb/(kg)                          | 76 lb. (34.5 kg)  |
| Dimensions - Rackmount WxDxH in (mm)    | w/o Side Supp. Tab: 16.73 in x 24.38 in x 5.22 in<br>(425 mm x 619 mm x 133 mm)<br>w/ Side Supp. Tab: 19.03 in x 24.38 in x 5.22 in<br>(483 mm x 619 mm x 133 mm)   |
| Dimensions - Tower WxDxH in (mm)        | Standard: 5.22 in x x 24.38 in x 16.73 in<br>(133 mm x 619 mm x 425 mm)<br>Caster Option: 5.22 in x 29.29 in x 17.48 in<br>(133 mm x 744 mm x 4445 mm)  |
| Clearance - Rackmount (in/mm)           | Front - 32 in., Rear - N/A in.,<br>Top/Bottom - 0 in., Sides N/A  |
| Clearance - Tower (in/mm)               | Front - 32 in., Rear - 4 in.,<br>Sides/Top - 0 in., Bottom N/A  |
| Enclosure                               | Enclosure of unit made from sheet metal, meets NEMA 1 and UL Type 1 Standard  |
| Construction                            | Unit enclosure made from sheet metal meeting NEMA 1 and UL Type 1 Standard  |

## Appendix B: T1000 Menu Table

\* - Changing parameter requires restarting Unit.

| TOP MENU       | SUB MENU                         | SUB-MENU PARAMETER | PARAMETER RANGE & FORMAT                  |
|----------------|----------------------------------|--------------------|---|
| On-Line STATUS | Input Freq., Out Freq., and Menu |                    |   |
| MENU           |                                  |                    |   |
| Quick Config   | ** QUICK CONFIG **               |                    |   |
|                |                                  | Rated Vin          | 208/240 V                                 |
|                |                                  | Rated Vout         | 200, 208, 220, 230, 240 (User selectable) |
|                |                                  | Vout Adjust        | -10 to +10 V, in 1 V steps                |
|                |                                  | Batt Ins Date      | mm/dd/yyyy                                |
|                |                                  | UPS Date           | Ddd mm/dd/yyyy (Mon 01/13/2013)           |
|                |                                  | UPS Time           | hh:mm AM (or PM)                          |
|                |                                  | En Batt Test*      | Enable/Disable                            |
| Monitor        | ** MONITOR **                    |                    |   |
|                | > Identification                 | Manufacturer       | TOSHIBA                                   |
|                |                                  | Typeform*          | e.g. – UH3B2060C6                         |
|                |                                  | Serial No.         | nnnnnnnn (e.g. - 080112345)               |
|                |                                  | Main Fw are Ver    | Main Firmware Version                     |
|                |                                  | Main BSector Ver   | e.g. – UH3MSV00001                        |
|                |                                  | Main BLoader Ver   | e.g. – UH3MBL0100                         |
|                |                                  | EEPROM Ver         | e.g. – JB0123456789                       |
|                |                                  | System Name        | e.g. – POD2                               |

\* - Changing parameter requires restarting Unit.

| TOP MENU        | SUB MENU                | SUB-MENU PARAMETER | PARAMETER RANGE & FORMAT         |
|-----------------|-------------------------|--------------------|----------------------------------|
| Monitor (Cont.) | >Identification (Cont.) | Attach Devices     | NONE or                          |
|                 |                         | Install Date       | yyyymmdd                         |
|                 | >Input                  | Input Config       | 1 Phase/240V-60Hz (e.g.)         |
|                 |                         | Input Voltage      | nnnV                             |
|                 |                         | Input Current      | nn.nA                            |
|                 |                         | Input Frequency    | nn.nHz                           |
|                 |                         | Input Power(W)     | nnnnW                            |
|                 |                         | Input Power(VA)    | nnnnVA                           |
|                 |                         | Rated Iin          | 5.2 kVA – 22.5A<br>6kVA – 26.0 A |
|                 |                         | Input Voltage(%)   | nnn%                             |
|                 |                         | Input Current(%)   | nnn%                             |
|                 |                         | Rated InPower(W)   | 5.2 kVA – 5200W<br>6kVA – 6000W  |
|                 | >Output                 | Output Config      | 1 Phase/230V-60Hz (e.g.)         |
|                 |                         | Output Voltage     | nnnV                             |
|                 |                         | Output Current     | nn.nA                            |
|                 |                         | Output Frequency   | nn.nHz                           |
|                 |                         | Output Power(W)    | nnnnW                            |
|                 |                         | Output Power(VA)   | nnnnVA                           |
|                 |                         | Output Load(%)     | nnn%                             |
|                 |                         | Rated Pout (W)     | 5.2 kVA – 4680W<br>6 kVA – 5400W |

\* - Changing parameter requires restarting Unit.

| TOP MENU        | SUB MENU             | SUB-MENU PARAMETER | PARAMETER RANGE & FORMAT                                  |
|-----------------|----------------------|--------------------|---|
|                 |                      | Rated Pout (VA)    | 5.2 kVA – 5200VA<br>6 kVA – 6000VA                        |
|                 |                      | Rated PF           | 0.9   |
|                 |                      |                    |   |
| Monitor (Cont.) | >Bypass              | Bypass Config      | 1 Phase/240V-60Hz (e.g.)                                  |
|                 |                      | Bypass Voltage     | nnnV  |
|                 |                      | Bypass Current     | nn.nA   |
|                 |                      | Bypass Frequency   | nn.nHz  |
|                 |                      | Bypass Power(VA)   | nnnnVA  |
|                 |                      |                    |   |
|                 | >Battery             | Battery Voltage    | nnnVdc  |
|                 |                      | Discharge Current  | nn.nAdc   |
|                 |                      | Battery Capacity   | nnn% (Percent of total available battery energy)          |
|                 |                      | Battery Runtime    | nnSec (Range 0 - 65535)                                   |
|                 |                      | Charger Status     | Normal / Preventative / Stop                              |
|                 |                      | Total Discharges   | range: 0 - 232  |
|                 |                      | Batt Sdown Level   | 79% of nominal 216 V full Batt. Charge                    |
|                 |                      | Batt Ins Date      | mm/dd/yyyy  |
|                 |                      | Low Batt Level     | 90% of nominal 216 V full Batt. Charge                    |
|                 |                      |                    |   |
|                 | >Status Config & Ctl | System(CTL) Temp   | nnC (°C)  |
|                 |                      | Battery Temp       | nnC (°C)  |
|                 |                      | Current State      | Shutdown / Online / Backup / Batt Test / Bypass / Startup |

\* - Changing parameter requires restarting Unit.

| TOP MENU | SUB MENU             | SUB-MENU PARAMETER | PARAMETER RANGE & FORMAT  |
|----------|----------------------|--------------------|---|
|          |                      | EPO Status         | Open / Closed   |
|          |                      | Inter Comm Status  | Normal / Unknown / Disable / Error                              |
|          |                      | Batt Test Cond     | “Ready for Test” or “Batt Test Prohibited”                      |
|          |                      |                    |   |
| Settings | ** SETTING **        |                    |   |
|          | >Input               | Rated Vin          | 208, 240  |
|          |                      |                    |   |
|          | >Output              | Rated Vout*        | 200, 208, 220, 230, 240   |
|          |                      | Rated Iout         | 5.52 kVA – 21.6 A<br>6 kVA – 25 A /                             |
|          |                      | Vout Adjust        | -10 to +10 V, in 1 V steps                                      |
|          |                      |                    |   |
|          | >Bypass              | BypUV Det Lvl      | Range: 75% to 95%   |
|          |                      | BypOV Det Lvl      | Range: 105% to 118%   |
|          |                      |                    |   |
|          | >Battery             | Batt Life Remain   | 32547Hr (Nominal remaining life based on battery life warranty) |
|          |                      | Rated Ahr          | 9 Ahr   |
|          |                      | No Batt (Series)   | nn (e.g. – 18 in one Battery Module)                            |
|          |                      | No Batt(Paral)     | n (e.g. – 1 in one Battery Module)                              |
|          |                      | Batt Ins Date      | mm/dd/yyyy  |
|          |                      |                    |   |
|          | >Status Config & Ctl | Requested State    | (On-Line / Bypass / Shutdown / Batt Test)                       |
|          |                      | Faults             | 0X00000000  |
|          |                      | Warnings           | 0X00000000  |

\* - Changing parameter requires restarting Unit.

| TOP MENU         | SUB MENU                     | SUB-MENU PARAMETER | PARAMETER RANGE & FORMAT                     |
|------------------|------------------------------|--------------------|--|
|                  |                              | UPS Status (Comm)  | 0X00000000                                   |
|                  |                              | En CVCF*           | Enable/Disable Frequency Conversion firmware |
|                  |                              | CVCF Frequency*    | 50.0Hz/60.0Hz                                |
|                  |                              | UPS Date           | Ddd mm/dd/yyyy                               |
|                  |                              | UPS Time           | hh:mm AM (or PM)                             |
| Settings (Cont.) | >Status Config & Ctl (Cont.) | En Startup Delay*  | Enable/Disable                               |
|                  |                              | Startup Mode*      | On-line/Shutdown/Bypass                      |
|                  |                              | Startup Timer*     | nnnSec (Range: 0 - 800)                      |
|                  |                              | Mode of Rmt Sdown  | Bypass / Shutdown                            |
|                  |                              | En Batt Test Sup*  | Enable/Disable                               |
|                  |                              | En Batt Test*      | Enable/Disable                               |
|                  |                              | Batt Test Freq     | Monthly/Weekly/Daily                         |
|                  |                              | Service Port Mode  | Protocol (Default) /Terminal (Factory only)  |
|                  |                              | En Restart         | Enable/Disable                               |
|                  |                              | Restart Delay      | 10 Sec (range 0-800 sec)                     |
|                  |                              | En AutoXfer        | Enable/Disable                               |
|                  |                              | AutoXfer Window    | 3sec (Range- 0-600 sec)                      |
|                  |                              | Restart Mode*      | On-line/Bypass/Shutdown                      |
|                  |                              |                    |  |
|                  | >History                     | System Op Time     | nnnnnSec (Up to 10 digits)                   |
|                  |                              | Inverter Op Time   | nnnnnSec (Up to 10 digits)                   |
|                  |                              | Backup Op Time     | nnnnnSec (Up to 10 digits)                   |
|                  |                              | UPS Lifetime       | nnnnnHr (Up to 10 digits)                    |

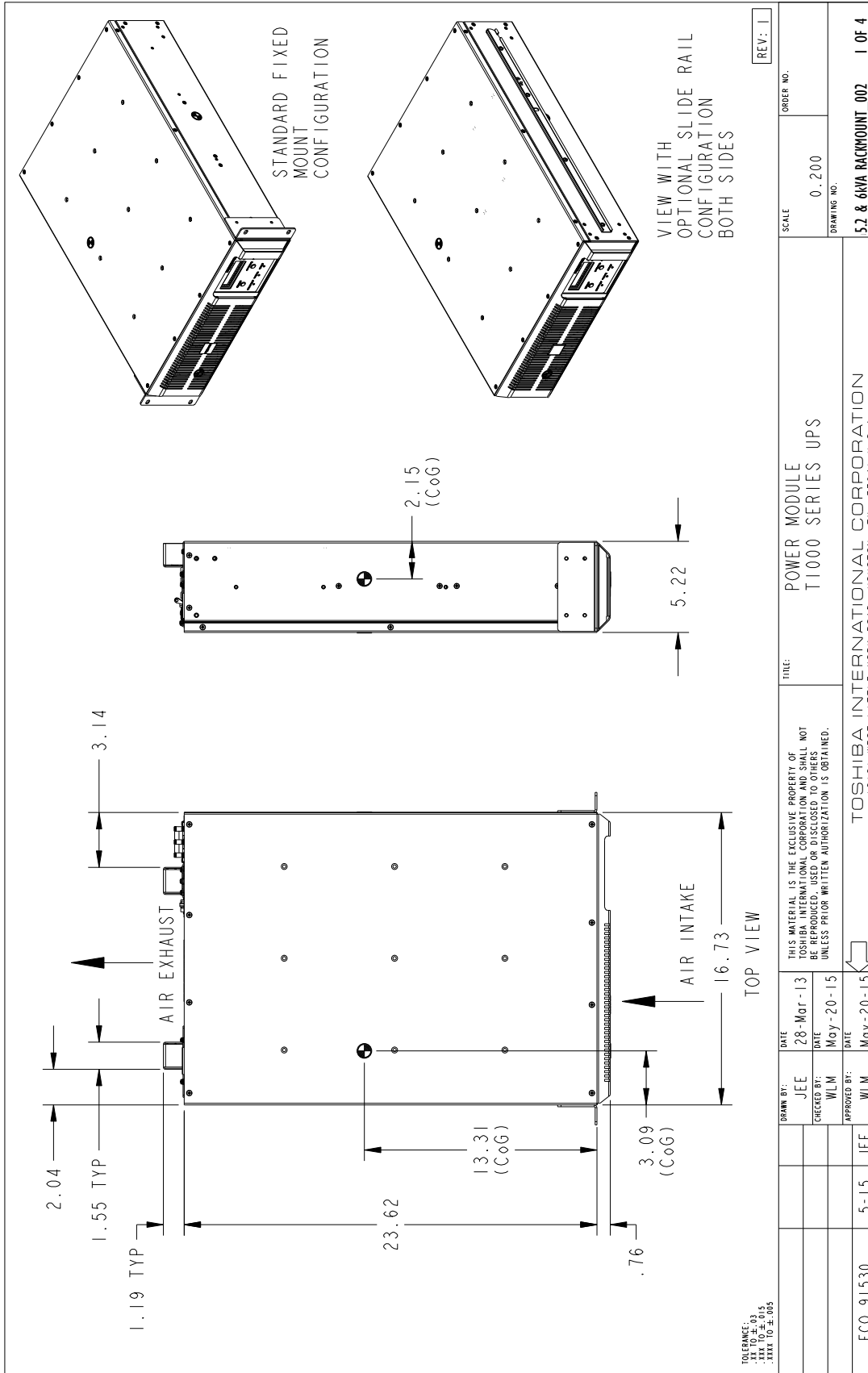
\* - Changing parameter requires restarting Unit.

| TOP MENU         | SUB MENU            | SUB-MENU PARAMETER | PARAMETER RANGE & FORMAT      |
|------------------|---------------------|--------------------|-------------------------------|
|                  |                     | Max System Temp    | nnC (°C)                      |
|                  |                     | Max Battery Temp   | nnC (°C)                      |
|                  |                     | Total VIUVs        | nnnn (Up to 10 digits)        |
|                  |                     | Total OLS          | nnnn (Up to 10 digits)        |
|                  |                     | Total Backups      | nnnn (Up to 10 digits)        |
| Settings (Cont.) | >History (Cont.)    | Total Faults       | nnnn (Up to 10 digits)        |
|                  |                     | Total Mode Change  | nnnn (Up to 10 digits)        |
|                  |                     | Total Warnings     | nnnn (Up to 10 digits)        |
|                  |                     | Total Sys Change   | nnnn (Up to 10 digits)        |
|                  |                     |                    |                               |
| Settings (Cont.) | >Display & Ext Comm | DFW Ver            | Display Firmware Version      |
|                  |                     | RMTI Ins Dat       | yyyymmdd                      |
|                  |                     | RMTI Version       | RemotEye version              |
|                  |                     | RMTI IP            | nnn.nnn.nnn.nnn               |
|                  |                     | RMTI Network Mask  | nnn.nnn.nnn.nnn               |
|                  |                     | RMTI Gateway IP    | nnn.nnn.nnn.nnn               |
|                  |                     | RMTI Status        | Uninstalled or Installed      |
|                  |                     | RMTI Netlink       | Link Down / Link Up / Unknown |
|                  |                     |                    |                               |
| Records          | ** RECORDS **       |                    |                               |
|                  | >Fault              |                    | Rec No. nn (1 to 32)          |
|                  | >Warning            |                    | Rec No. nn (1 to 32)          |
|                  | >Backup             |                    | Rec No. nn (1 to 32)          |
|                  | >Operation          |                    | Rec No. nn (1 to 32)          |

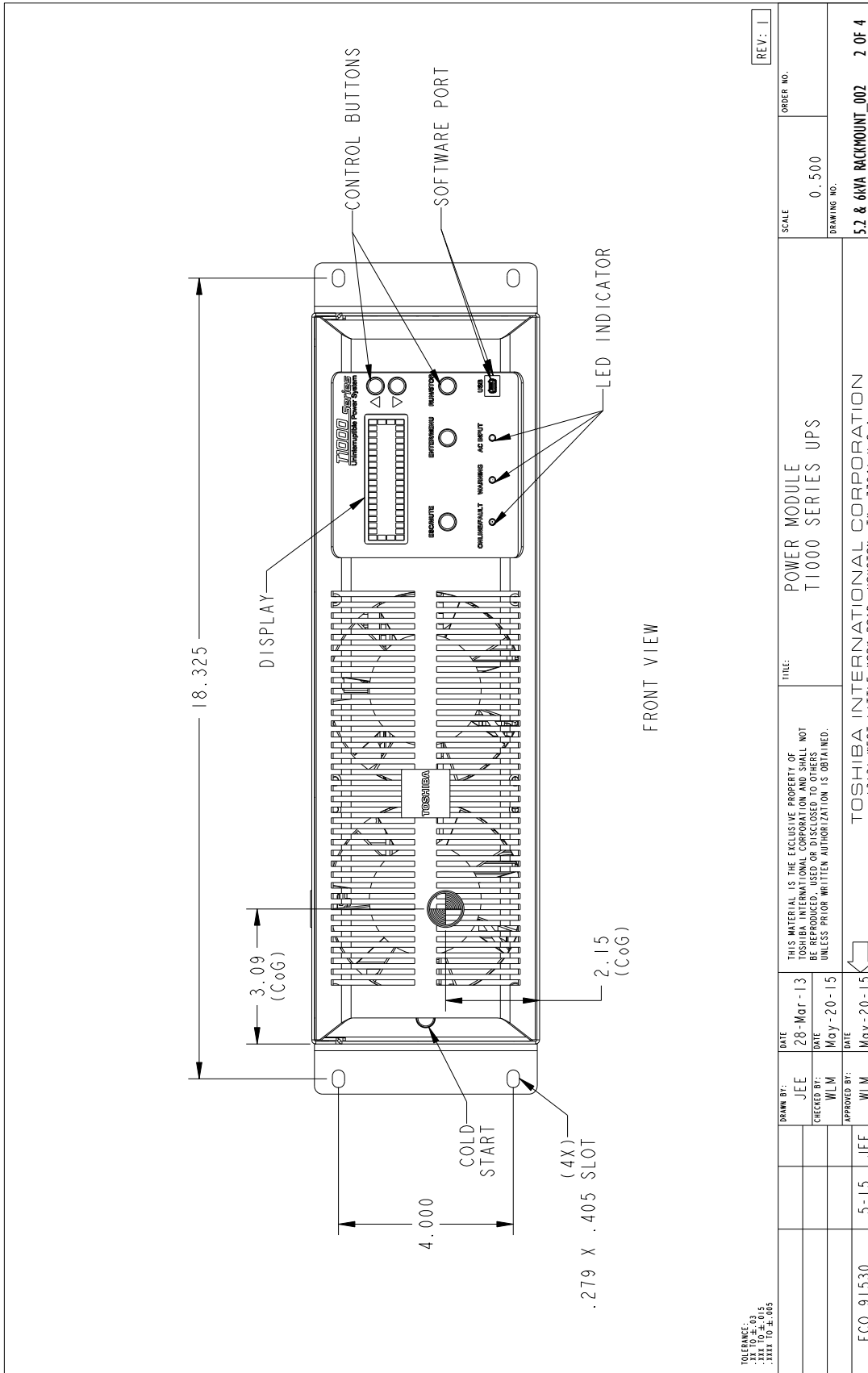
\* - Changing parameter requires restarting Unit.



# Appendix C: T1000 Dimensional Drawings



**FIGURE C-1: T1000 POWER MODULE - OVERVIEW**



FRONT VIEW

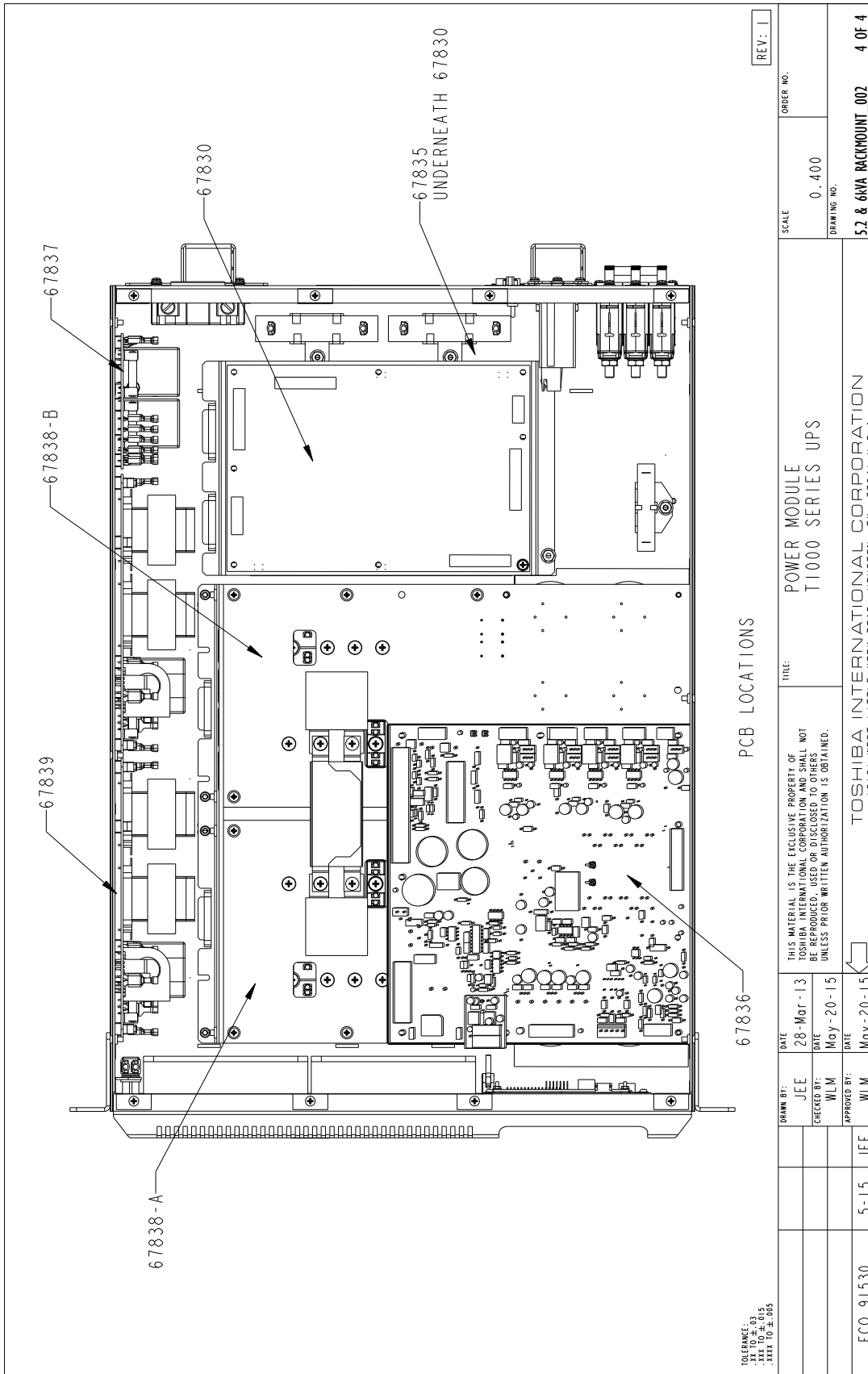
TOLERANCE:  
.XX TO ±.03  
.XXX TO ±.015  
.XXXX TO ±.005

REV: 1

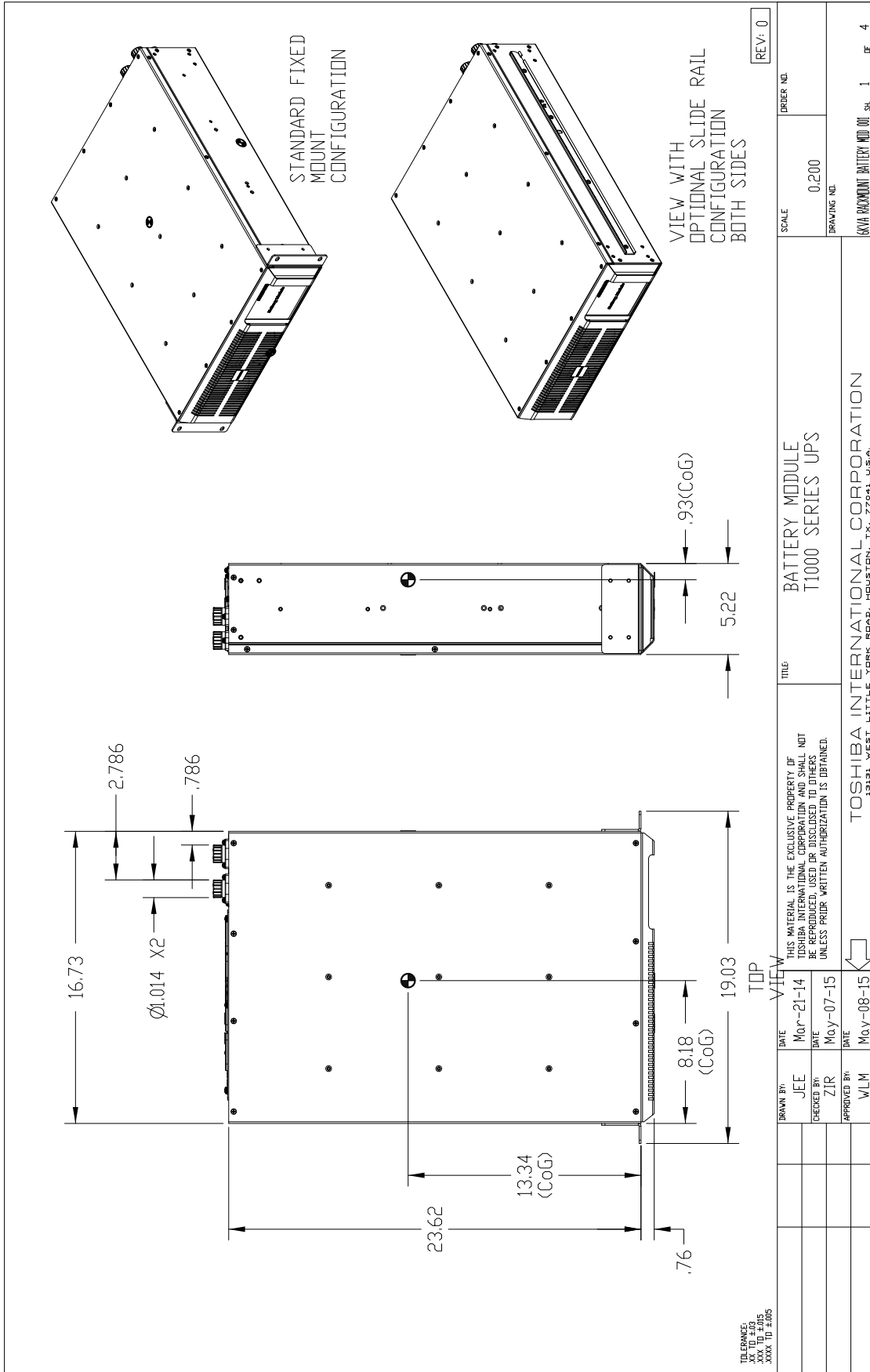
|  |           |   |       |                                  |       |       |           |                          |
|--|-----------|---|-------|----------------------------------|-------|-------|-----------|--------------------------|
| DATE   | 28-Mar-13 | THIS MATERIAL IS THE EXCLUSIVE PROPERTY OF TOSHIBA INTERNATIONAL CORPORATION AND SHALL NOT BE REPRODUCED, USED OR DISCLOSED TO OTHERS UNLESS PRIOR WRITTEN AUTHORIZATION IS OBTAINED. | TITLE | POWER MODULE<br>T1000 SERIES UPS | SCALE | 0.500 | ORDER NO. |                          |
| DRAWN BY:  | JEE       |   |       |                                  |       |       |           |                          |
| CHECKED BY:  | WLM       |   |       |                                  |       |       |           |                          |
| APPROVED BY:   | JEE       |   |       |                                  |       |       |           |                          |
| DATE   | 5-15      |   |       |                                  |       |       |           |                          |
| DATE   | May-20-15 |   |       |                                  |       |       |           |                          |
| DATE   | May-20-15 |   |       |                                  |       |       |           |                          |
| ECO 91530  |           |   |       |                                  |       |       |           | 5.2 & 6kVA RACKMOUNT_002 |
|  |           |   |       |                                  |       |       |           | 2 OF 4                   |
| TOSHIBA INTERNATIONAL CORPORATION<br>13131 WEST LITTLE YORK ROAD, HOUSTON, TX, 77041, U.S.A. |           |   |       |                                  |       |       |           |                          |

FIGURE C-2: T1000 POWER MODULE - FRONT

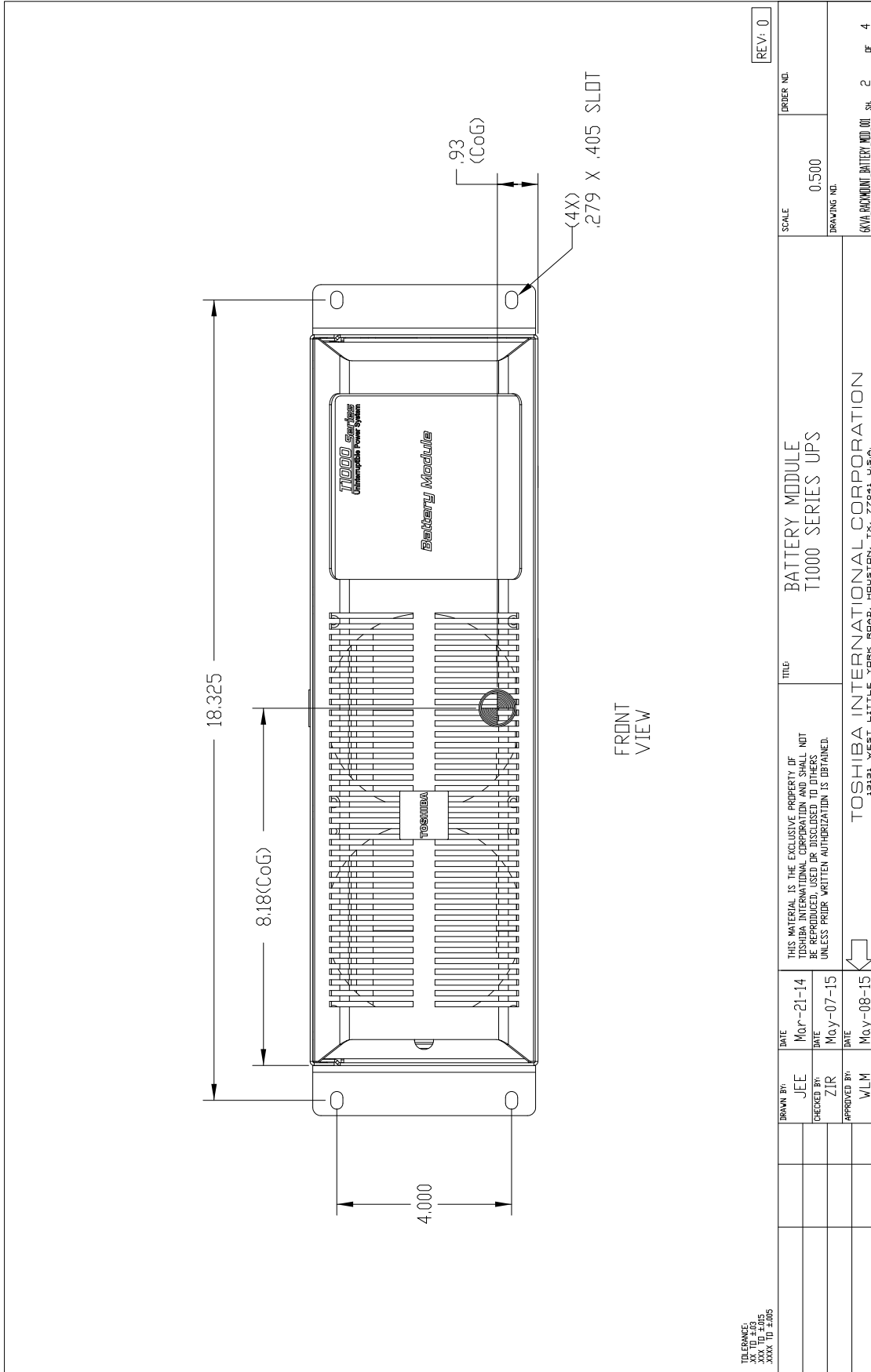




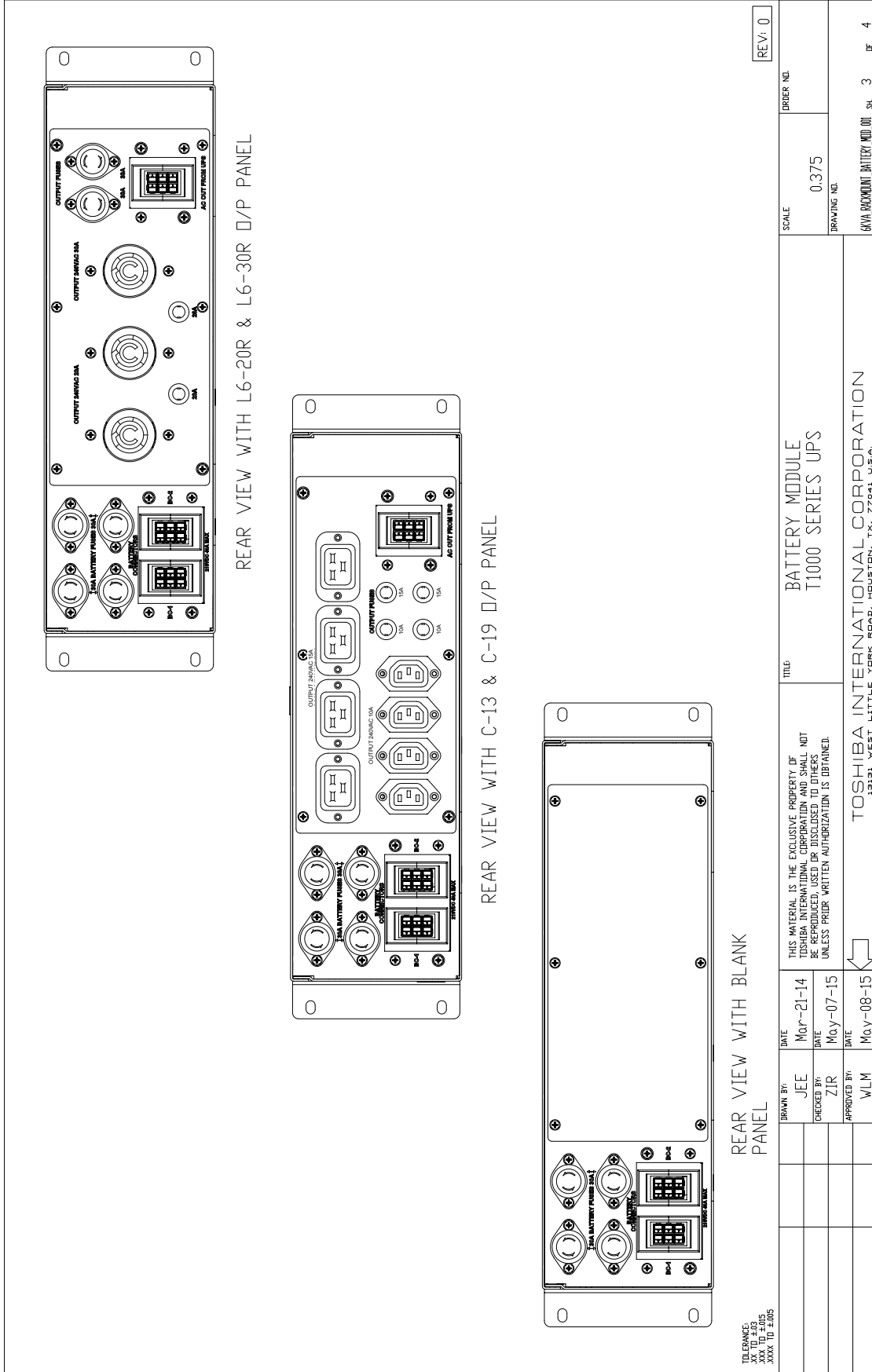
**FIGURE C-4: T1000 POWER MODULE - PCB LOCATIONS**



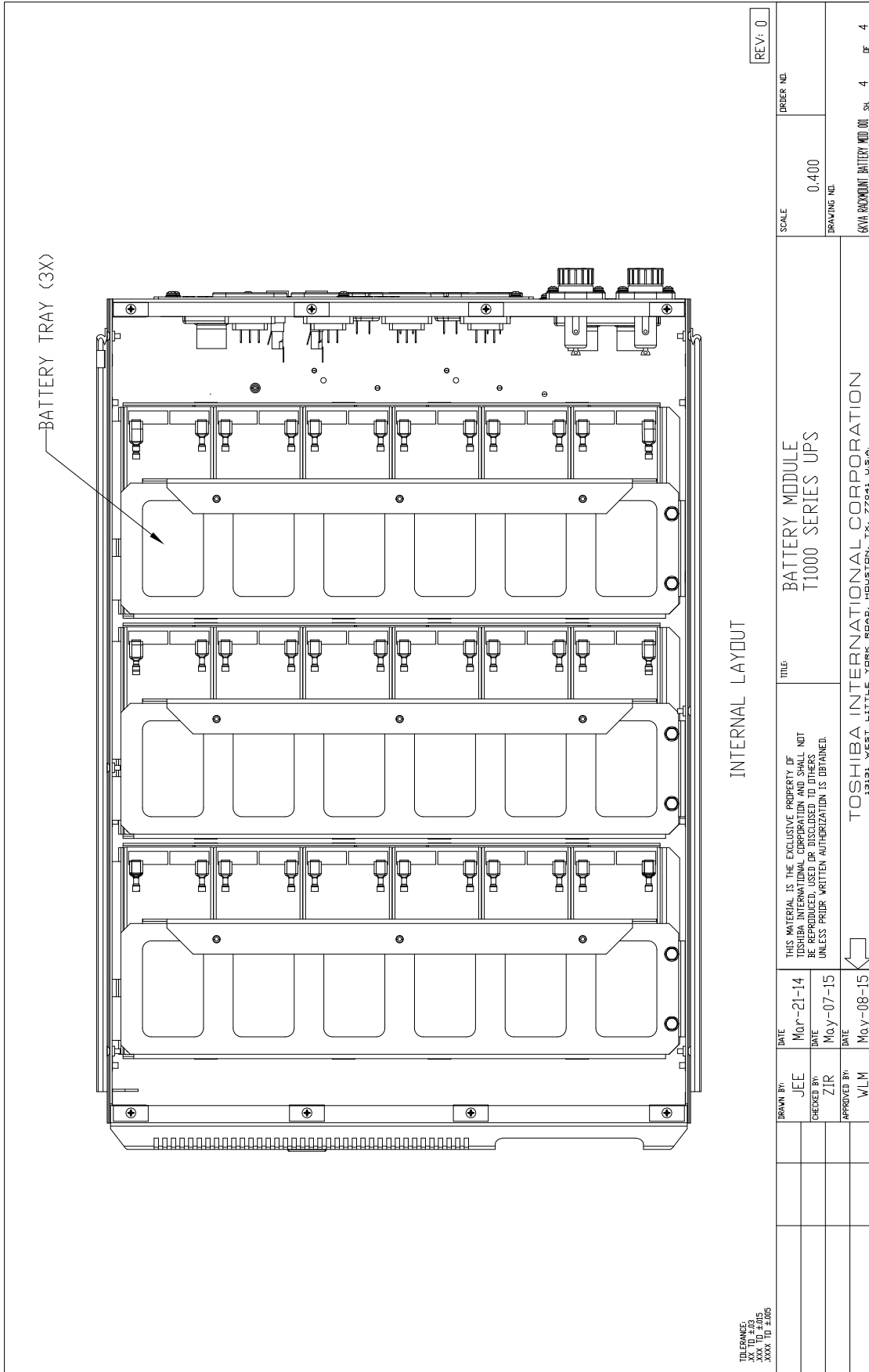
**FIGURE C-5: T1000 BATTERY MODULE - OVERVIEW**



**FIGURE C-6: T1000 BATTERY MODULE - FRONT**



**FIGURE C-7: T1000 BATTERY MODULE - REAR**

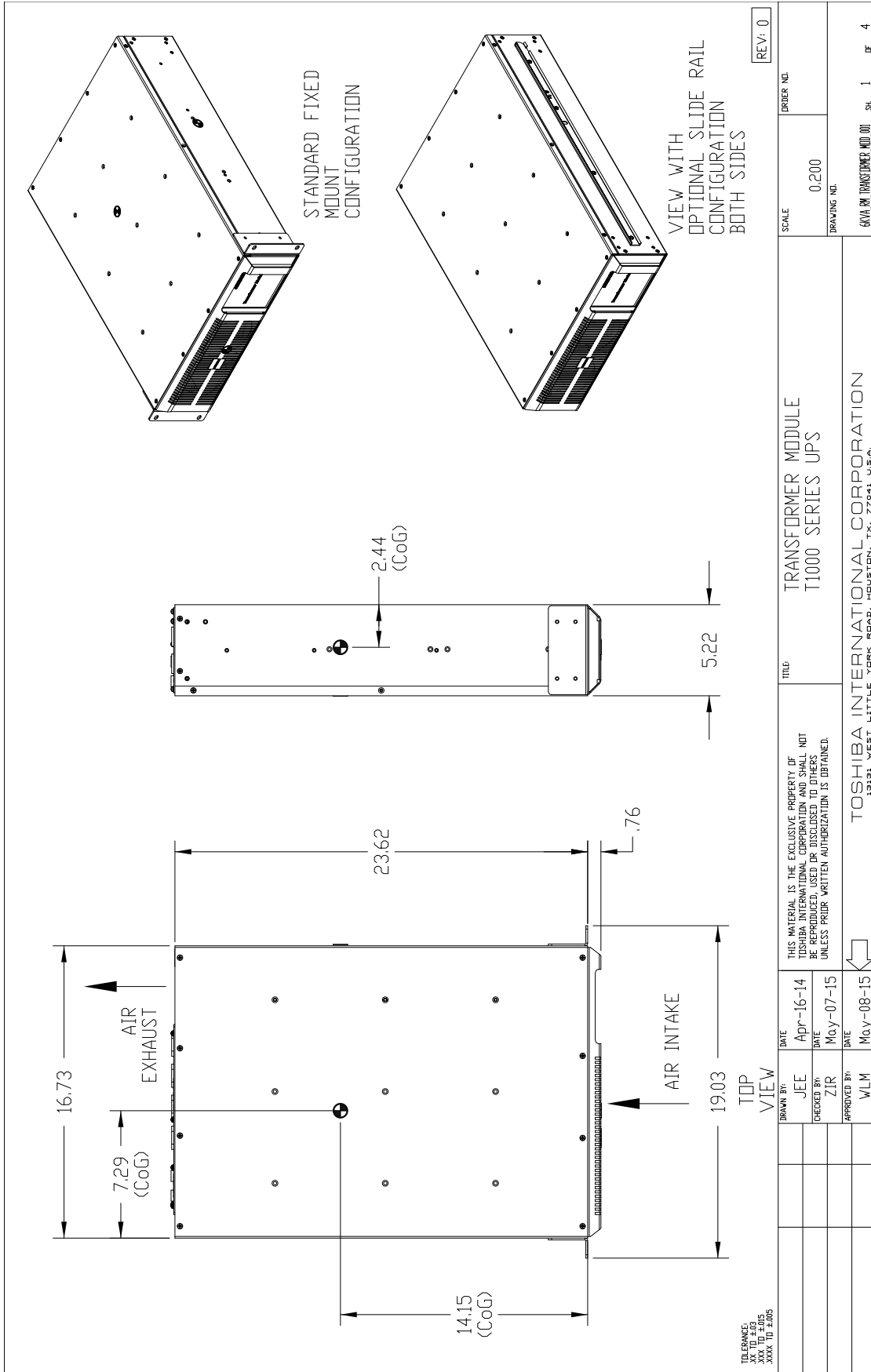


INTERNAL LAYOUT

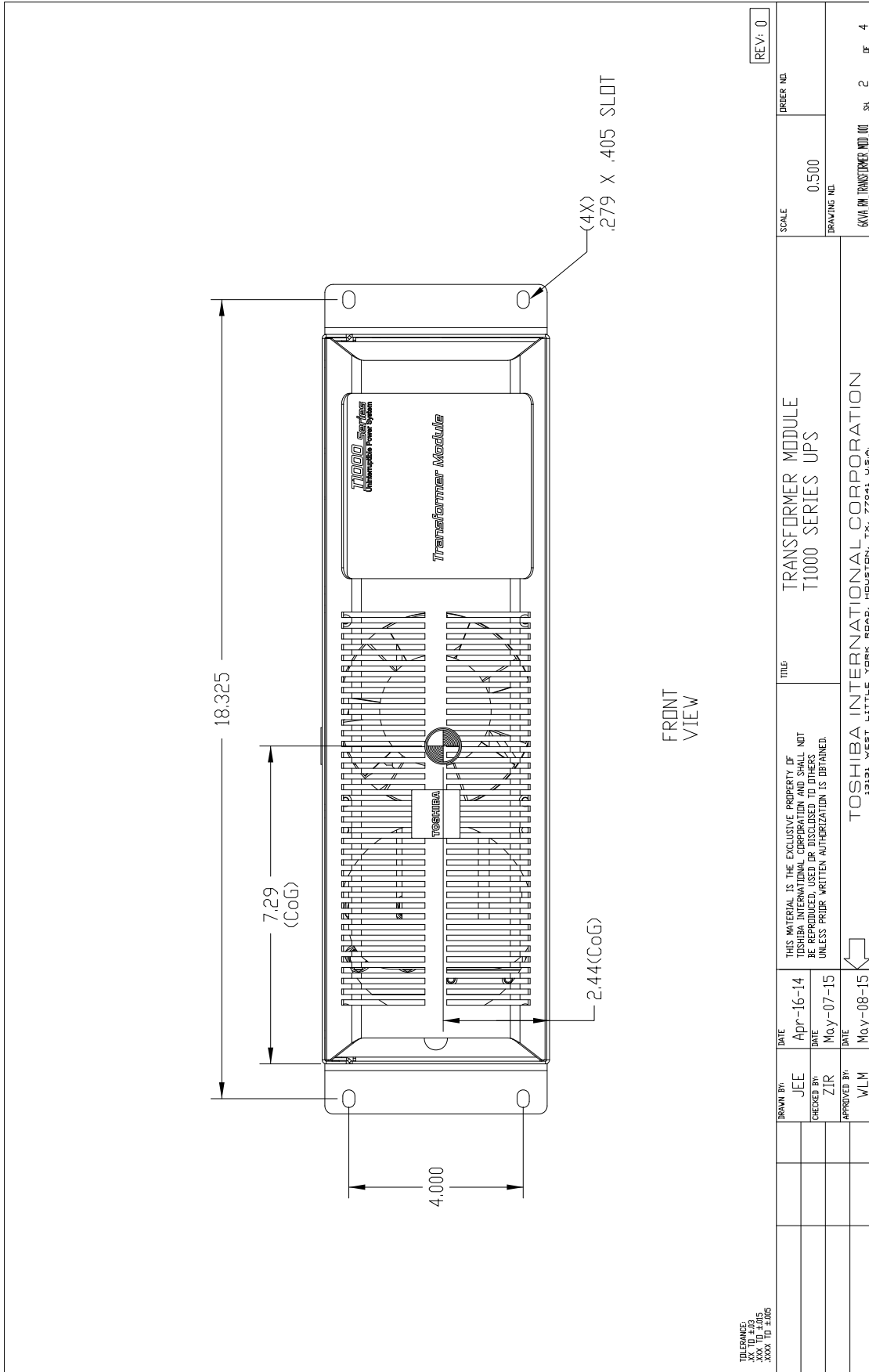
|   |                    |   |
|---|--------------------|---|
| TOL. FINANCE:<br>XX TO #10<br>XXX TO #05<br>XXXX TO #005  |                    | REV: 0  |
| DRAWN BY:<br>JEE  | DATE:<br>Mar-21-14 | SCALE:<br>0.400                                     |
| CHECKED BY:<br>ZIR  | DATE:<br>May-07-15 | DRAWING NDL:<br>6KVA BACKMOUNT_BATTERY_MOD_001_SH_4 |
| APPROVED BY:<br>WLM   | DATE:<br>May-08-15 | DRAWING NDL:<br>6KVA BACKMOUNT_BATTERY_MOD_001_SH_4 |
| THIS MATERIAL IS THE EXCLUSIVE PROPERTY OF TOSHIBA INTERNATIONAL CORPORATION AND SHALL NOT BE REPRODUCED, USED OR DISCLOSED TO OTHERS UNLESS PRIOR WRITTEN AUTHORIZATION IS OBTAINED. |                    |   |
| TOSHIBA INTERNATIONAL CORPORATION<br>13131 WEST LITTLE LANE ROAD, HOUSTON, TX 77041 U.S.A.  |                    |   |

FIGURE C-8: T1000 BATTERY MODULE - INTERNAL LAYOUT





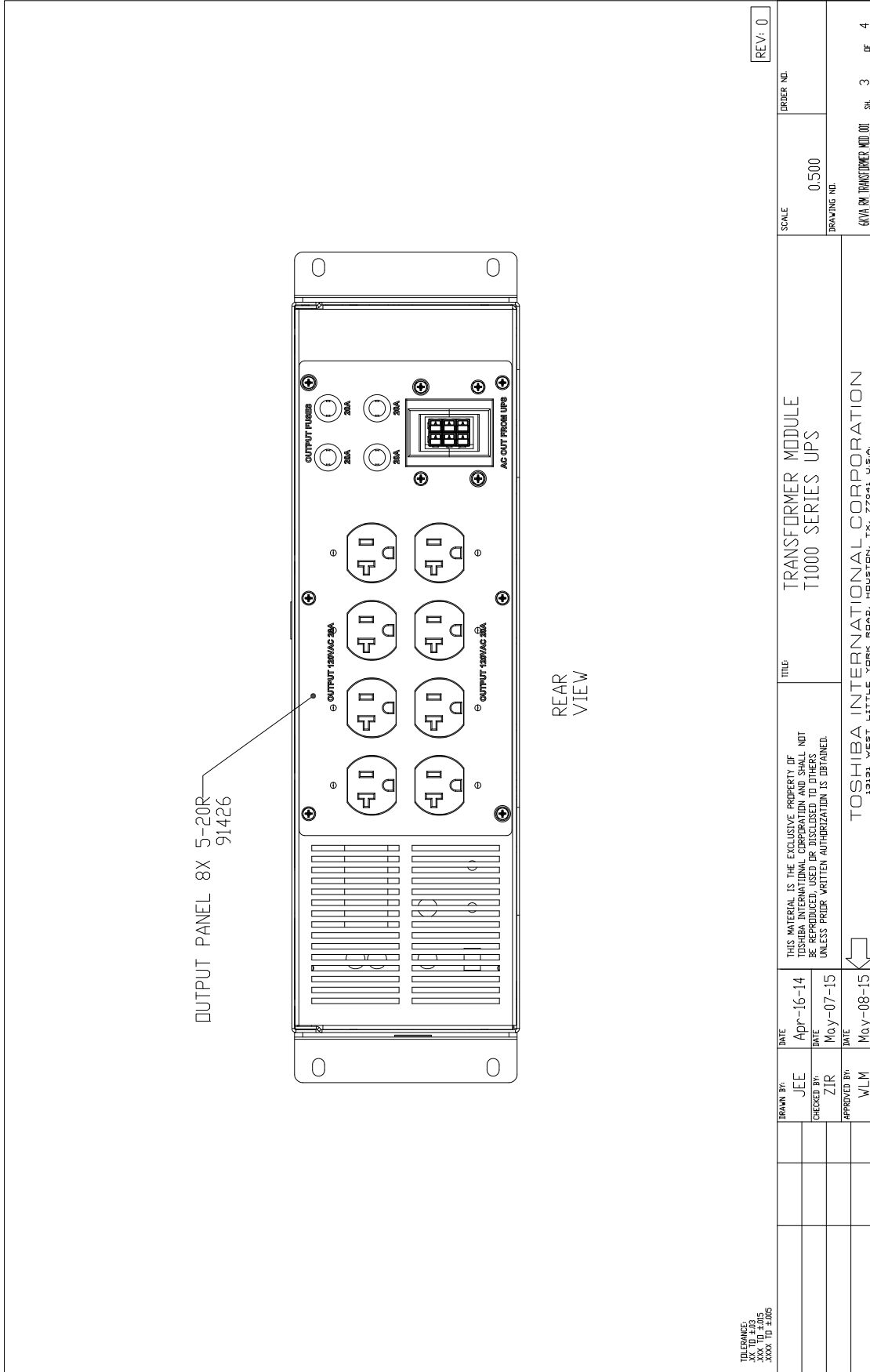
**FIGURE C-9: T1000 TRANSFORMER MODULE - OVERVIEW**



TOL FRANGE:  
XX TO ±.03  
XXX TO ±.05  
XXXX TO ±.065

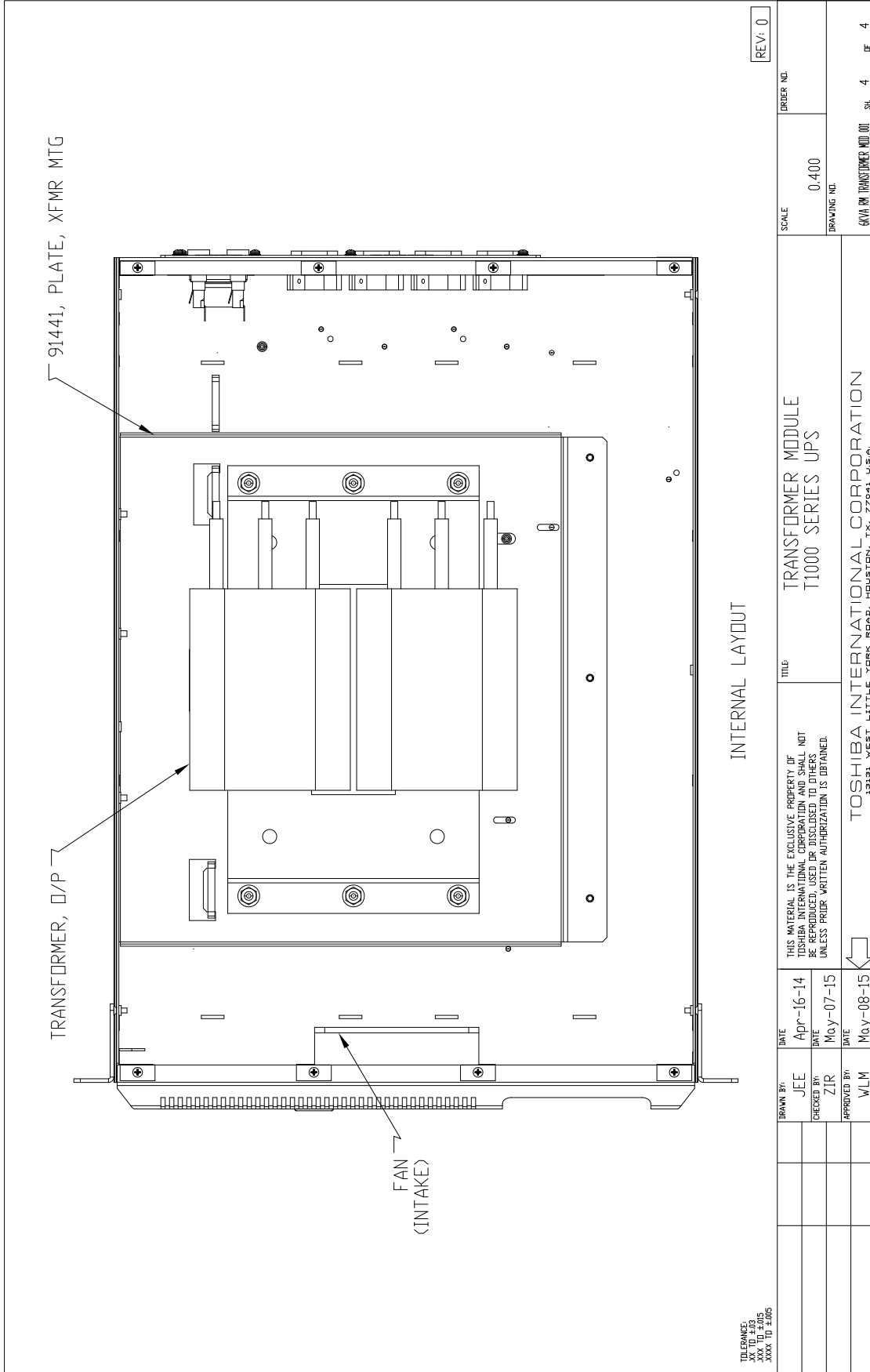
|                     |                    |  |  |                 |             |
|---------------------|--------------------|--|--|-----------------|-------------|
| DRAWN BY:<br>JEE    |                    | DATE:<br>Apr-16-14   | TITLE:<br>TRANSFORMER MODULE<br>T1000 SERIES UPS | SCALE:<br>0.500 | DRAWER NO.: |
| CHECKED BY:<br>ZIR  | DATE:<br>May-07-15 | THIS MATERIAL IS THE EXCLUSIVE PROPERTY OF<br>TOSHIBA INTERNATIONAL CORPORATION AND SHALL NOT<br>BE REPRODUCED, USED OR DISCLOSED TO OTHERS<br>UNLESS PRIOR WRITTEN AUTHORIZATION IS OBTAINED. |  |                 |             |
| APPROVED BY:<br>WLM | DATE:<br>May-08-15 | TOSHIBA INTERNATIONAL CORPORATION<br>13131 WEST LITTLE LANE ROAD, INDUSTRIAL PK. 77041 U.S.A.  |  |                 |             |
|                     |                    |  | DRAWING NO.<br>6VA_0M_TRANSFORMER_MOD_Sk_2 OF 4  |                 |             |
| REV: 0              |                    |  |  |                 |             |

**FIGURE C-10: T1000 TRANSFORMER MODULE - FRONT**



|   |  |                     |                    |  |                 |           |
|---|--|---------------------|--------------------|--|-----------------|-----------|
| TOLERANCE<br>XX TO ±0.5<br>XXX TO ±0.05   |  | DRAWN BY:<br>JEE    | DATE:<br>Apr-16-14 | TITLE:<br>TRANSFORMER MODULE<br>T1000 SERIES UPS     | SCALE:<br>0.500 | ORDER NO. |
| THIS MATERIAL IS THE EXCLUSIVE PROPERTY OF TOSHIBA INTERNATIONAL CORPORATION AND SHALL NOT BE REPRODUCED, USED OR DISCLOSED TO OTHERS UNLESS PRIOR WRITTEN AUTHORIZATION IS OBTAINED. |  | CHECKED BY:<br>ZJR  | DATE:<br>May-07-15 | DRAWING NO.<br>6KVA_04_TRANSFORMER_MOD_001 SH 3 DF 4 |                 |           |
| TOSHIBA INTERNATIONAL CORPORATION<br>1313 WEST LITTLE LANE ROAD, HOUSTON, TX, 77061 U.S.A.  |  | APPROVED BY:<br>WLM | DATE:<br>May-08-15 | REV: 0   |                 |           |

**FIGURE C-11: T1000 TRANSFORMER MODULE - REAR**



|   |                     |                    |   |   |  |                 |           |
|---|---------------------|--------------------|---|---|--|-----------------|-----------|
| TOLERANCE<br>XX TO ±.05<br>XXX TO ±.005<br>XXX TO ±.005 |                     | DRAWN BY:<br>JEE   | DATE:<br>Apr-16-14  | THIS MATERIAL IS THE EXCLUSIVE PROPERTY OF TOSHIBA INTERNATIONAL CORPORATION AND SHALL NOT BE REPRODUCED, USED OR DISCLOSED TO OTHERS UNLESS PRIOR WRITTEN AUTHORIZATION IS OBTAINED. | TITLE:<br>TRANSFORMER MODULE<br>T1000 SERIES UPS | SCALE:<br>0.400 | ORDER NO. |
|   | CHECKED BY:<br>ZIR  | DATE:<br>May-07-15 |   |   | DRAWING NO.<br>6KVA_04_TRANSFORMER_MODULE        | SH. 4           | DF 4      |
|   | APPROVED BY:<br>WLM | DATE:<br>May-08-15 | TOSHIBA INTERNATIONAL CORPORATION<br>13131 WEST LITTLE LANE ROAD, HOUSTON, TX, 77041 U.S.A. |   |  |                 |           |

**FIGURE C-12: T1000 TRANSFORMER MODULE - INTERNAL LAYOUT**

## Appendix D: T1000 Packing Lists and Kit Contents

The T1000 can be ordered in many different configurations. Use the Part Number on your unit(s) to check against the packing lists below. Notify your vendor immediately of any variances.

**TABLE D-1: T1000 PACKAGE CONTENTS**

| UPS Module                    | Manual Pack | Interconnect Cables (see D.2.5)  | Mounting Kit  |
|-------------------------------|-------------|--|---|
| <b>Power Module (5.2 kVA)</b> |             |  |   |
| T1P0A5200GXGL1                | 91075       | (None)   | Tower Cap: 1 per System<br>2 Modules - P/N 93177<br>3 Modules - P/N 93178 |
| T1P0A5200GXGR3L1              | 91075       | (None)   | 1 of installation Kit 92802.  |
| <b>Power Module (6 kVA)</b>   |             |  |   |
| T1P0A6000GXG                  | 91075       | (None)   | Tower Cap: 1 per System<br>2 Modules - P/N 93177<br>3 Modules - P/N 93178 |
| T1P0A6000GXGR3                | 91075       | (None)   | 1 of installation Kit 92802.  |
| <b>Battery Module 1</b>       |             |  |   |
| T1B06000005                   | 91075       | 1 ea. 92855 - Batt. DC to Pwr Module DC  | (See Tower Pwr Module)  |
| T1B06000005P1                 | 91075       | 1 ea. 92855 - Batt. DC to Pwr Module DC<br>1 ea. 92858 - Pwr Module L6-30 Out to Batt. Panel Anderson Input (240V) |   |
| T1B06000005P2                 | 91075       | 1 ea. 92855 - Batt. DC to Pwr Module DC<br>1 ea. 92858 - Pwr Module L6-30 Out to Batt. Panel Anderson Input (240V) |   |
| T1B06000005R3                 | 91075       | 1 ea. 92855 - Batt. DC to Pwr Module DC  | 1 of installation Kit 92802.  |
| T1B06000005R3P1               | 91075       | 1 ea. 92855 - Batt. DC to Pwr Module DC<br>1 ea. 92858 - Pwr Module L6-30 Out to Batt. Panel Anderson Input (240V) |   |
| T1B06000005R3P2               | 91075       | 1 ea. 92855 - Batt. DC to Pwr Module DC<br>1 ea. 92858 - Pwr Module L6-30 Out to Batt. Panel Anderson Input (240V) |   |
| <b>Battery Module 2</b>       |             |  |   |
| T1B06000005                   | 91075       | 1 ea. 92855 - Batt. Module 1 DC to Batt Module 2 DC  | (See Tower Pwr Module)  |
| T1B06000005R3                 | 91075       | 1 ea. 92855 - Batt. Module 1 DC to Batt Module 2 DC  | 1 of installation Kit 92802.  |
| <b>Transformer Module</b>     |             |  |   |
| T1X06000GA-N1                 | 91075       | 1 ea. 92858 - 240V Anderson to L6-30P<br>1 ea. 92883 - 208V Anderson to L6-30P                                     | (See Tower Pwr Module)  |
| T1X06000GA-N1-R3              | 91075       | 1 ea. 92858 - 240V Anderson to L6-30P<br>1 ea. 92883 - 208V Anderson to L6-30P                                     | 1 of installation Kit 92802.  |

### Inter-Module Cabling Identification

- 92855 - Pwr Module "EXT. BATTERY" to BC1 CN12A- DC/Thermistor Connector
- 92858 - Power Module L6-30 Output to Batt. Module Receptacle Panel or Xfmr Module (240V tap)
- 92883 - Power Module L6-30 Output to Xfmr Module Input (208V tap)



## Appendix E: T1000 Optional Installation Kit Instructions

The T1000 can be installed in several configurations with the aid of optional installation kits.

### E.1 Optional 3-Module Tower Cap Kit - 93178

#### T1000 Series UPS Tower Cap Installation Instructions - 94037-000

An Optional Tower Cap Kit are available for 3-module T1000 tower systems. If the optional Caster Kits are to be used, the casters should be installed before the Tower Cap is installed.

#### 1 Tower Cap Kit

The tower configuration modules are arranged side by side, and secured by a press-fit cap over the assembly.

#### 2 Contents - Tower Cap Kit (1 Cap per UPS System)

- 1 ea.: T1000 Series UPS Tower Cap Installation Instructions - 94037
- 1 ea.: 93178 - Tower Cap for 3 module System

#### 3 Install Tower Cap

NOTE: If optional Caster Kits, P/N 90508, are to be used, install them before installing the Tower Cap.

1. Unpack the T1000 modules and set them in the desired location with the faceplates at the top as shown below. (Figure 2-A)
2. Facing the front of the modules, arrange them left to right in the following order:
  - Transformer Module (if available)
  - Power Module
  - Battery Module with output panel(if available)
  - Second Battery Module without output panel (if available)
3. Locate the front of the Tower Cap. The front of the Cap has three tabs extending beyond the skirt line. See Figure 1.
4. Fit the Tower Cap over the T1000 Modules, beginning with the front and lower the bak end over the top back of the modules.
5. Press the T1000 Tower Cap over the tower modules (Figure 2-B).
6. TThe T1000 tower is ready for installing the interconnecting cables. See the T1000 Installation and Operation Manual - 91074.

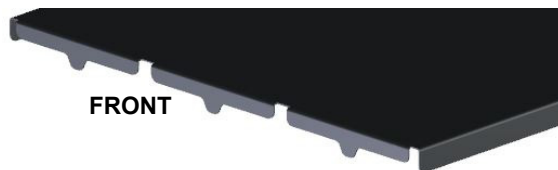


FIGURE 1: TOWER CAP FRONT - DETAIL

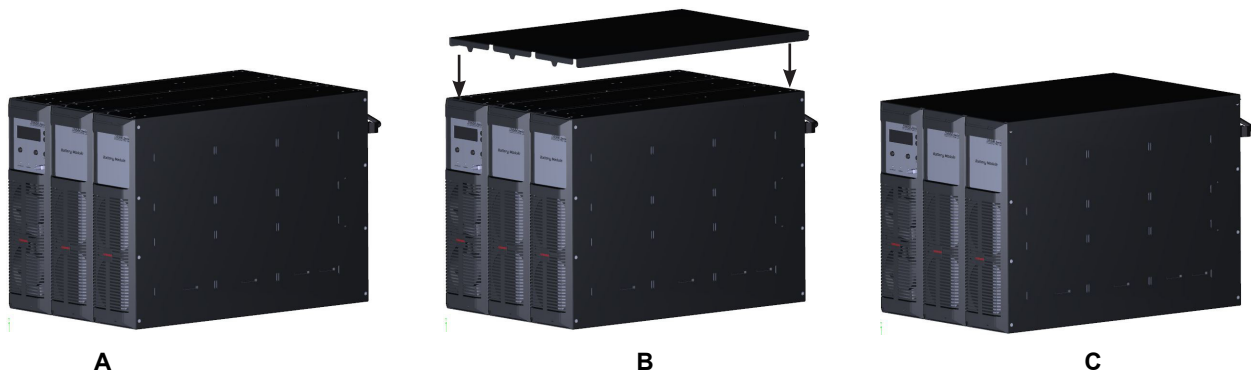


FIGURE 2: INSTALL CAP ON THREE MODULE TOWER SYSTEM

## E.2 Optional Tower Caster Kit - 90508

### T1000 Series UPS Tower Caster Kit Installation Instructions - 94031-000

#### 1. T1000 Tower Caster Kit

The tower configuration modules may be modified with an optional Caster Kit containing a pair of caster and leveling foot assemblies. Each module requires one Caster Kit.

#### 2. Contents - T1000 Tower Caster Kit (90508)

- 1 ea.: Tower Caster Kit Installation Instructions - 94031
- 2 ea.: 91438 - Caster Bracket, Black
- 2 ea.: 91439 - Connector Plate, Black
- 2 ea.: Knob, Leveling, 1/4"-20
- 2 ea.: Leveling Feet, Female
- 4 ea.: Caster, 2x appliance, 5/16"-18
- 4 ea.: Nut Cap, 5/16"-18
- 4 ea.: Washer, Belville, 5/16
- 7 ea.: Screw PHP (Pan Head Phillips) 10-32 x 1/2

#### 3. Caster Kit Installation

Unpack the T1000 modules and assemble and install the casters as follows.

##### CASTER ASSEMBLY

1. Insert each caster appliance's threaded shafts through the Caster Bracket. (Figure 1)
2. Place a 5/16" Belville Washer over each caster shaft, then screw on the 5/16"-18 nut cap. Tighten the nut cap but do not bottom out the washer.
3. Repeat Steps 1-2 for the second caster appliance.
4. Screw the leveling knob through the 1/4"-20 pimnut in the Caster Bracket. (Figure 1, Figure 2)
5. Press the Leveling Foot over the end of the leveling knob shaft. (Figure 2)
6. Repeat Steps 1-5 for the remaining Caster Bracket.

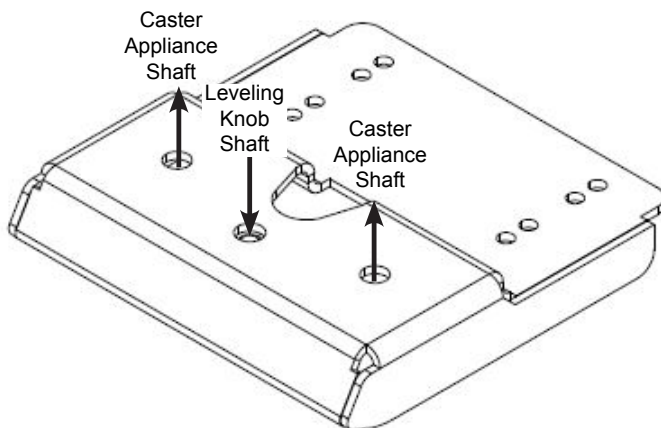


FIGURE 1 CASTER BRACKET

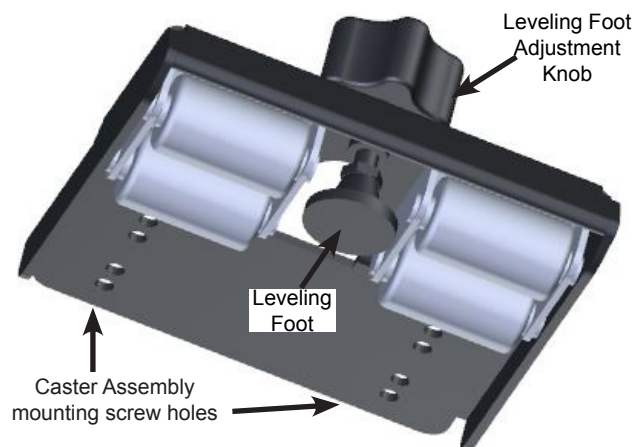


FIGURE 2 CASTER ASSEMBLY - DETAIL

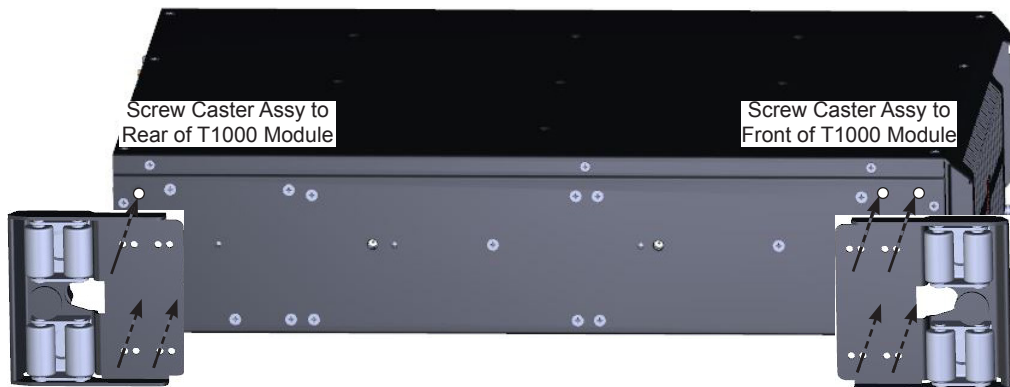


#### 4. CASTER INSTALLATION

1. Lay each module on it's side so that the display/Name panel is on the right side as you face the front of the module. Position the module so you're facing the bottom of the unit. (Figure 3)
2. Locate the three caster mounting holes on the left side, and four mounting holes on the right side of the module. (Figure 3)
3. Secure one caster assembly to the rear base of the module using three (3) 10-32 x 1/2 Philips Screws. (Figure 4)
4. Secure the remaining caster assembly to the front base of the module using four (4) 10-32 x 1/2 Philips Screws. (Figure 4)
5. Repeat steps 7-10 for each module in the system.



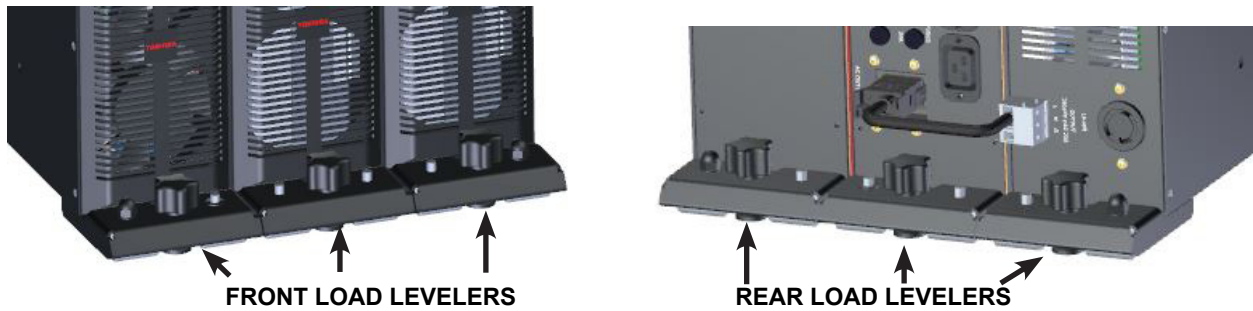
**FIGURE 3: POSITION MODULE FOR CASTER INSTALLATION**



**FIGURE 4: ATTACH CASTER ASSEMBLIES**

6. Set the module(s) upright on the casters.
7. Position the module(s) near their final installation location.  
**NOTE: The casters roll in a straight line, but do not swivel. To turn the module, slide the front or back end laterally to change direction.**
8. Facing the front of the modules, arrange the modules left to right in the following order:
  - Transformer Module (if available)
  - Power Module
  - Battery Module with output panel(if available)
  - Second Battery Module without output panel (if available)

1. Align the units and place the Tower Cap on the system.
  - 2 module tower systems, see **T1000 Installation and Operation Manual - 91074**.
  - 3-4 module tower systems, see **T1000 Tower Cap Installation Instructions - 94037**.
2. Use the leveling feet to remove weight from the casters. (Figure 5)
3. The T1000 tower is ready for installing the interconnecting cables. See the **T1000 Installation and Operation Manual - 91074**.



**FIGURE 5: USE LOAD LEVELERS TO STABILIZE TOWER ASSEMBLY**

### E.3 Optional T1000 2-Post Rack Fixed Installation Kit - 92801

#### T1000 Series UPS 2-Post Rack Fixed Kit Installation Instructions - 94035-000

#### 1. Rackmount Fixed Installation - 2-Post

Use the 2-Post Fixed Rackmount Kit 92801 (1 kit per module) to mount a T1000 module in a 2-Post 19 inch rack.

#### 2. Contents - Fixed 2-Post Rack Installation Kit (92801)

- 1 ea.: T1000 2-Post Rack Fixed Installation Kit Instructions - 94035
- 4 ea.: 92756 - Bracket, Fixed Mounting, 2-Post, Black
- 16 ea.: Cage Nut, 1/4"-20
- 16 ea.: Hex bolt, 1/4"-20 x 5/8"
- 16 ea.: Nut, Spin Lock, 1/4"-20 G5
- 12 ea.: Screw, PHP (Pan Head Phillips) 10-32 x 1/2" St Box
- 4 ea.: Screw, PHP 8-32 x 1/4" St Zi

#### 3. Prepare the 2-Post Rack (for rack rails with square holes)

1. Each 2-Post Fixed Mounting Bracket has 6 rack mounting holes. Place the bracket over the Rack Rail at the lowest desired elevation for the system modules. Ensure all 6 bracket holes align with rack rail holes.
2. Clip one cage nut (Cage Nut, 1/4"-20) at the top hole location on the rack rail, then clip cage nuts on the rack rail in the 2nd, 5th, and 6th hole position on the rack rail.

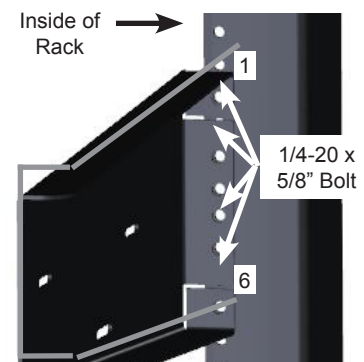
*NOTE: Ensure all bracket slots align with the rack rail mounting holes to establish the bottom unit elevation.*

*NOTE: If installing more than one T1000 module, begin with the lowest module first.*

3. Repeat step 2 for the other three mounting bracket locations for the bottom module.
4. If more than one module is being installed for the T1000 system, install the next set of cage nuts from the other module's 4-Post Slide Kit three (3) Rack Units (5 1/4") above the first set of cage nuts (Figure 5). Repeat steps 2-3.
5. Repeat steps 2-4 until cage nuts for all the modules in the system have been clipped on the 2-Post rack.

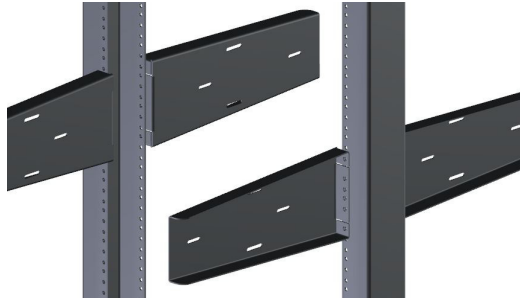
#### 4. Install the 2-Post Rack Fixed Brackets

1. Bolt the 2-Post Fixed Bracket assembly to the 2-Post Rack using four (4) 1/4"-20 x 5/8" bolts for each bracket. (Figure 1)
2. Hold one of the 2-Post Fixed Mounting Brackets, P/N 92756, against the 2-Post rack rail at the level of the lowest module to be installed, with the bracket folds to the inside of the 2-Post rack (Figure 1).
3. Each 2-Post Fixed Mounting bracket has 6 rack mounting holes. Slip the hex bolt through the top (first) hole through the rack mounting flange and secure it with the cage nut (square holes) or 1/4"-20 Spin Lock Nut (round holes).
4. Slip a bolt through each of the brackets 2nd, 5th, and 6th holes and secure each with the cage nut (square holes) or 1/4"-20 Spin Lock Nut (round holes).
5. Repeat Steps 2-4 for remaining three mounting brackets (Figure 2).
6. If more than one module is being installed for the T1000 system,



**FIGURE 1: 2-POST FIXED BRACKET RACK MOUNTING**

install the remaining mounting kits as described in steps 1-5 (Figure 3).



**FIGURE 2: INSTALL REMAINING 2-POST FIXED BRACKETS**



**FIGURE 3: INSTALL REMAINING MODULE BRACKETS**

#### 4. Install the Module in the 2-Post Rack

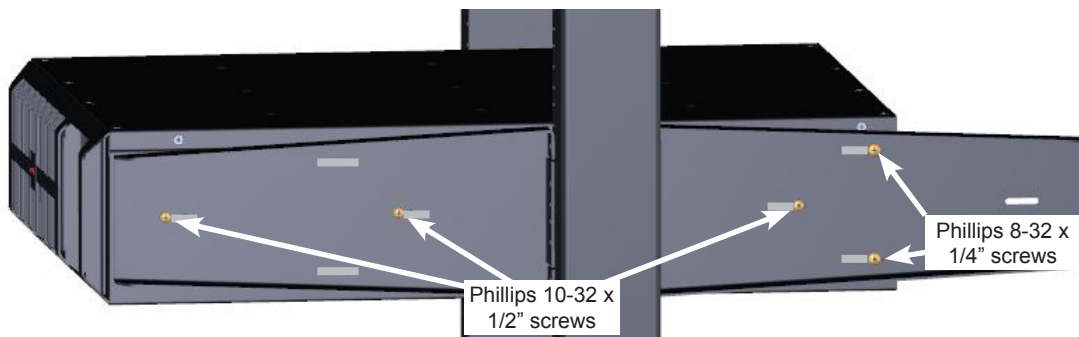


**CAUTION: Battery Modules weight 150 lb. (68 kg). Use lifting aids and proper lifting techniques.**

NOTE: The T1000 System modules must be arranged top-to-bottom in the following relative order:

- Transformer Module (if present)
- Power (UPS) Module
- Battery Module w/Output Panel (if present)
- Battery Panel w/o Output Panel (if present)

1. Follow the vertical arrangement of T1000 modules as indicated in the NOTE above. Secure the lowest module in the 2-Post rack to the bottom four brackets. (Figure 4)
  - Each Front Bracket: 2 x Phillips 10-32 x 1/2" in the center slots. (Figure 3)
  - Each Rear bracket: 1 x Phillips 10-32 x 1/2" in the center slots. and 2 x Phillips 8-32 x 1/4" screw each in the top and bottom slot, (Figure 4)
2. Repeat Step 7 for the remaining modules, working from bottom to top. (Figure 6)
3. Go to T1000 Installation and Operation Manual, 91074, for cabling instructions.



**FIGURE 4: MOUNT MODULE ON 2-POST FIXED BRACKETS**



**FIGURE. 5: INSTALL FIRST  
T1000 MODULE**



**FIGURE. 6: INSTALL REMAINING  
T1000 MODULES**

**E.4 Optional T1000 4-Post Rack Slide Installation Kit - 92800**

**T1000 Series UPS 4-Post Rack Slide Kit Installation Instructions- 94034-000**

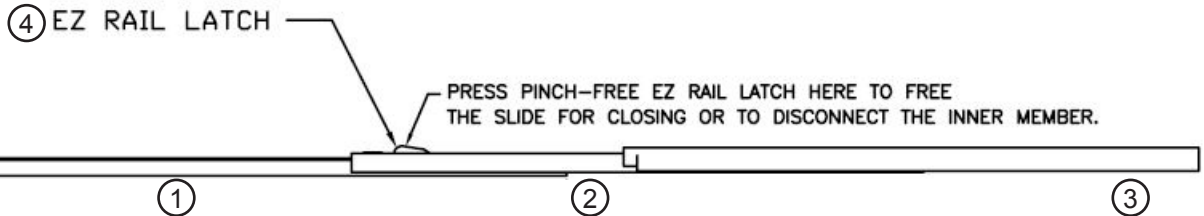
**1. 4-Post Rack Slide Kit**

Use the 4-Post Rack Slide Kit 92800 (1 kit per module) to mount a T1000 module with slides in a 19-inch, 4-Post rack. The slide assemblies are non-handed, and are provided with a lock-open feature and a quick disconnect for the Inner Slide Member. When the Inner Slide Member is disconnected, the E-Z Rail latch in the slide assembly locks the Middle Member in the fully open position until the Inner Member is reinstalled.

**2. Contents - 4-Post Rack Slide Installation Kit (92800)**

- 1 ea.: T1000 Series UPS 4-Post Rack Slide Kit Installation Instructions - 94034
- 2 ea.: Slide, 22 in., 370EZ-22
- 2 ea.: Bracket, Front Offset, SPO-538
- 2 ea.: Bracket, Rear Offset, SPO-552
- 8 ea.: Screw, FHP (Flat Head Phillips) 8-32 x 3/8 in.
- 8 ea.: Nut, serrated head, 8-32
- 8 ea.: Screw, PHP, (Pan Head Phillips) 8-32 x 1/4 in.
- 16 ea.: Cage Nut, 1/4"-20
- 16 ea.: Hex bolt, 1/4"-20 x 5/8" (with assembled washer)

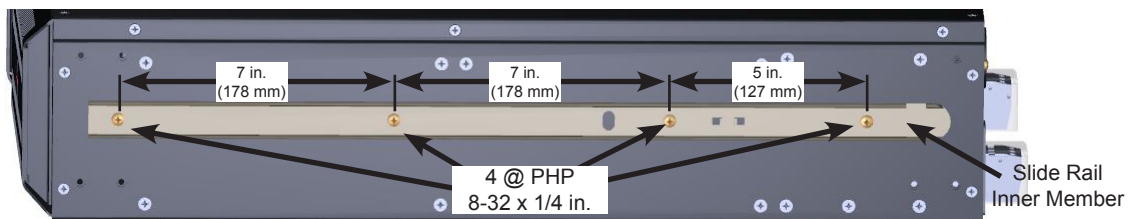
**3. Attach E-Z Rail to Module**



| No. | ITEM  |
|-----|---|
| 1   | Slide Rail Inner Member (EZ Rail)           |
| 2   | Slide Rail Middle Member                    |
| 3   | Slide Rail Outer Member (Outer Rail Sleeve) |
| 4   | E-Z Rail Latch                              |

**FIGURE 2 SLIDE ASSEMBLY**

- Remove the EZ Rail (Slide Rail Inner Member), Figure 2-(1), from the Slide Rail Middle Member, Figure 2-(2), by pressing the E-Z Rail Latch and sliding the EZ Rail out of the Middle Member. Repeat for the second Slide Assembly.
- Attach an EZ Rail to each side of the UPS module using 4 x Phillips 8-32 x 1/4". Orient the inner Slide Member so the rounded end is towards the rear of the module. (Figure 3)



**FIGURE 3: INSTALL INNER SLIDE MEMBER ON LEFT AND RIGHT SIDES OF MODULE(S)**

- Repeat Steps 1-2 for all modules to be installed.

#### 4. Attach Extender Brackets to Slide Assemblies

1. Ensure the Middle Slide Member, Figure 2-(2), is extended forward from the outer slide sleeve (outer slide member), Figure 2-(3).

Note: The Bracket to Slide Assy. fasteners are a screw secured with a serrated nut.

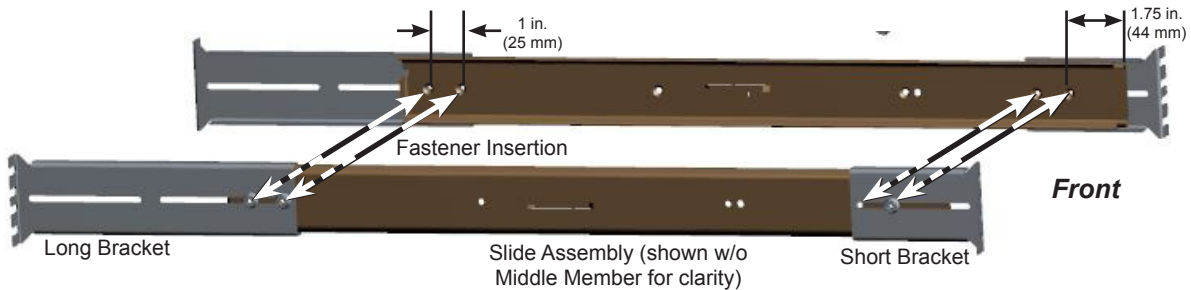
2. Attach the long bracket to the rear of the slide assembly with two #8-32 x 3/8 in. screws and serrated nuts (Figure 4). Insert the FHP screws from the inside out, so the nut is on the outside of the slide assembly.

*Do not over tighten the fasteners until the bracket assemblies have been mounted on the 4-Post rack.*

3. Repeat Step 2 for the second long bracket.
4. Attach the front (short) bracket to the front of the slide assembly with two (2) #8-32 x 3/8 in. screws and serrated nuts (Figure 4). Insert the screws through the access holes provided in the Middle Slide Member.

*Do not over tighten the fasteners until the bracket assemblies have been mounted on the 4-Post rack.*

5. Repeat step 4 for the second front bracket.



**FIGURE 4: ATTACH EXTENDER BRACKETS TO SLIDE ASSEMBLY**

#### 5. Attach Slide Assemblies to 4-Post Rack

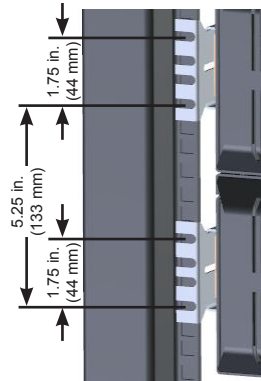
1. Remove the cage nuts from the Slide kit.
2. Clip one cage nut (Cage Nut, 1/4"-20) from the 92800 kit over each post's rack mounting hole at the desired elevation. The nut should be on the inside of the rack.

*NOTE: Ensure all bracket slots align with the rack rail mounting holes to establish the bottom unit elevation.*

*NOTE: If installing more than one T1000 module, begin with the lowest module first.*

3. Clip a second cage nut 1.75 in. above each cage nut installed in step 1 (Figure 5). The nut should be on the inside of the rack.
4. If more than one module is being installed for the T1000 system, install the next set of cage nuts from the other module's 4-Post Slide Kit three (3) Rack Units (5 1/4") above the first set of cage nuts (Figure 5). Repeat steps 2-3.
5. Repeat steps 2-4 until cage nuts for all the modules in the system have been clipped on the 4-Post rack.
6. Bolt the Side Rail/Bracket assembly to the 4-Post Rack using two 1/4"-20 x 5/8" hex bolts each on the front and back. Thread the hex bolt from the outside, thru the rack flange and into the cage nut.

*Ensure the end with the short adapter bracket is to the front of the rack. (See Figure 6)*



**FIGURE 5 CAGE NUT INSTALLATION**



7. Tighten the #8-32 screws used to assemble the Slide Assembly and Bracket Extenders in Section 4.
8. Repeat step 6-7 for the remaining Side Rail/Bracket assemblies. (Figure 7)

## 6. Install T1000 Modules in Rackmount Slides

**CAUTION: Battery Modules weight 150 lb. (68 kg). Use lifting aids and proper lifting techniques**

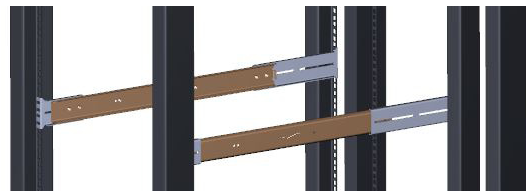


The T1000 System modules must be arranged top-to-bottom in the following relative order:

Transformer Module (if present)

- Power (UPS) Module
- Battery Module w/Output Panel (if present)
- Battery Panel w/o Output Panel (if present)

1. Lift the module intended for the bottom slide rail set, and slide the module's E-Z Rails into the extended Slide Middle Members.
2. Gently slide the module backward until the slides are fully retracted.
3. Repeat steps 1-2 for the module slide rail set immediately above the bottom one.
4. Continue until all modules have been installed on their slide rails.
5. Go to **T1000 Installation and Operation Manual - 91074** to continue installation and cabling of the T1000 System.



**FIGURE 6: INSTALL SLIDE RAIL ASSEMBLIES IN 4-POST RACK**



**FIGURE 7: INSTALL REMAINING SLIDE RAIL ASSEMBLIES IN 4-POST RACK**



**E.5 Optional T1000 2-Post Rack Slide Installation Kit - 90400**

**T1000 Series UPS 2-Post Rack Slide Kit Installation Instructions- 94030-001**

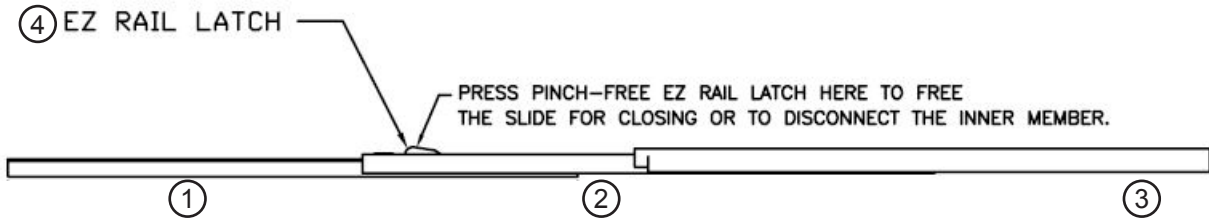
**1. 2-Post Rack Slide Kit**

Use the 2-Post Rack Slide Kit 90400 (1 kit per module) to mount a T1000 module with slides in a 19-inch, 2-Post rack. The slide assemblies are non-handed, and are provided with a lock-open feature and a quick disconnect for the Inner Slide Member. When the Inner Slide Member is disconnected, the E-Z Rail latch in the slide assembly locks the Middle Member in the fully open position until the Inner Member is reinstalled.

**2. Contents - 2-Post Rack Slide Installation Kit (90400)**

- 1 ea.: T1000 Series UPS 2-Post Rack Slide Kit Installation Instructions - 94030
- 2 ea.: Slide, 22 in., 370EZ-22
- 1 ea.: BK-4-EZ 2-Post Rack Bracket Kit, containing:**
  - 4 ea.: 2-Post Rack Bracket JES P/N 2496052
  - 8 ea.: Screw, FHP (Flat Head Phillips) 8-32 x 3/8 in.
  - 8 ea.: Nut, serrated head, 8-32
- 8 ea.: Screw, PHP, (Pan Head Phillips) 8-32 x 1/4 in. (for mounting inner slide member)
- 16 ea.: Cage Nut, 1/4"-20
- 16 ea.: SEMS Hex bolt, 1/4"-20 x 5/8" (with assembled washer) for racks with 1/4"-20 tapped holes.
- 16 ea.: SEMS Hex bolt, 10-32 x 5/8" (with assembled washer) for racks with 10-32 tapped holes.

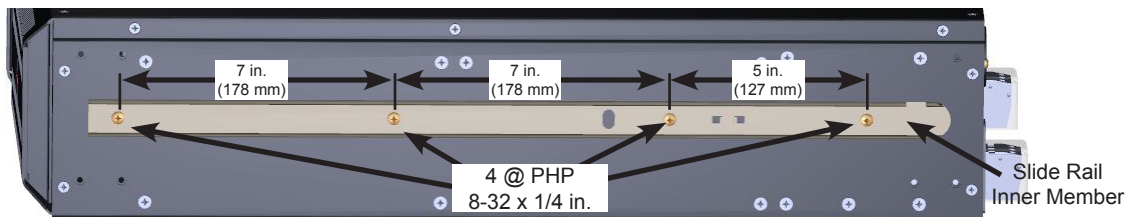
**3. Attach E-Z Rail to Module**



| No. | ITEM   |
|-----|--|
| 1   | Slide Rail Inner Member (EZ Rail)            |
| 2   | Slide Rail Middle Channel                    |
| 3   | Slide Rail Outer Channel (Outer Rail Sleeve) |
| 4   | E-Z Rail Latch                               |

**FIGURE 1 SLIDE ASSEMBLY**

1. Remove the EZ Rail (Slide Rail Inner Member), Figure 1-(1), from the Slide Rail Middle Channel, Figure 1-(2), by pressing the E-Z Rail Latch, Figure 1-(4), and sliding the EZ Rail out of the Middle Channel. Repeat for the second Slide Assembly.

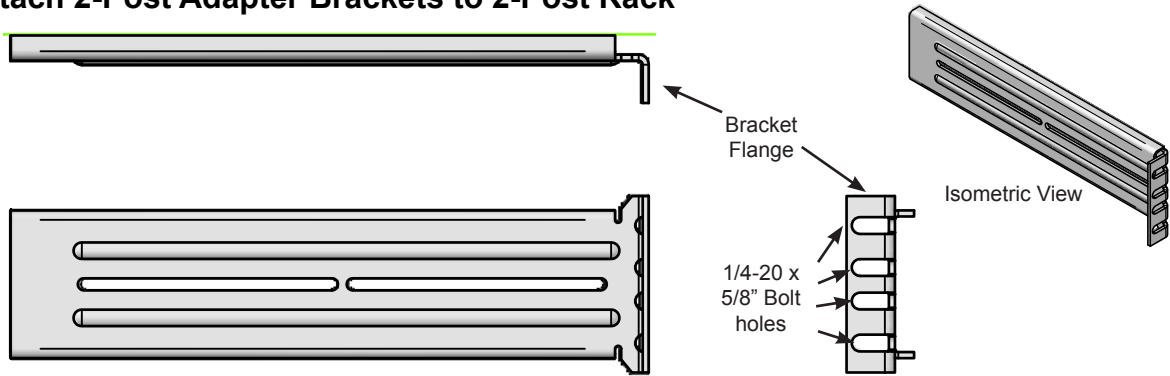


**FIGURE 2: INSTALL INNER SLIDE MEMBER ON LEFT AND RIGHT SIDES OF MODULE(S)**

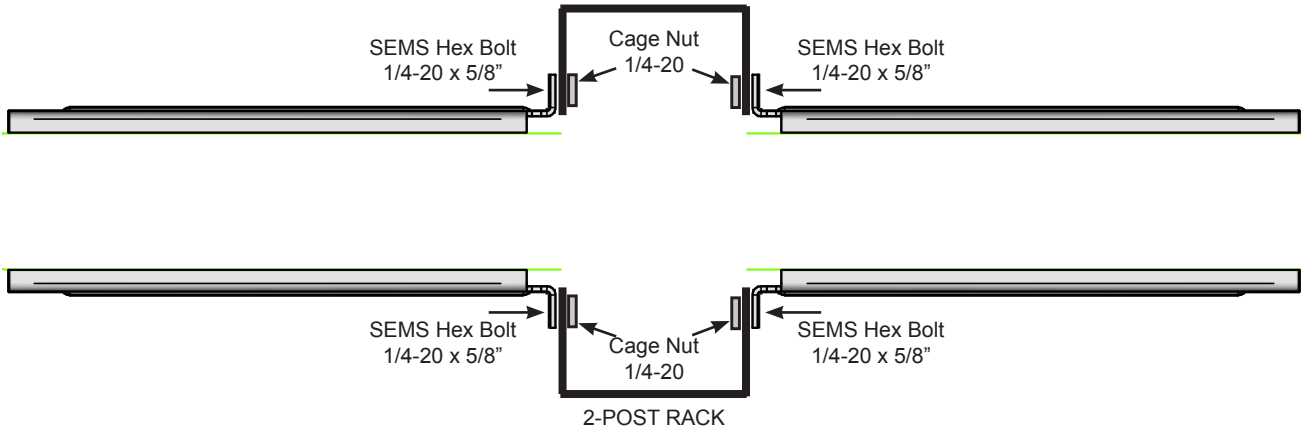
2. Attach an EZ Rail to each side of the UPS module using 4 x Phillips 8-32 x 1/4". Orient the inner Slide Member so the rounded end is towards the rear of the module. (Figure 2)

3. Repeat Step 1-2 for all modules to be installed.

**4. Attach 2-Post Adapter Brackets to 2-Post Rack**



**FIGURE 3: 2-POST SLIDE BRACKET (4 PER MODULE)**



**FIGURE 4: 2-POST SLIDE BRACKET INSTALLATION (USING CAGE NUTS. OTHER FASTENERS SIMILAR.)**

*NOTE: If Rack Rail holes are threaded, use either the 1/4-20 or 10-32 bolts included in the Installation Kit. If Rack rails have square penetrations, follow instructions below. \*\**

*NOTE: If installing more than one T1000 module, begin with the lowest module first.*

1. Remove the cage nuts from the Slide kit.
2. Hold one of the 2-Post mounting brackets, P/N 2496052, against the 2-Post mounting flange at the level of the lowest module to be installed, with the bracket flange, Figure 2, to the outside of the 2-Post rack (Figure 3).

*NOTE: Ensure all bracket slots align with the rack rail mounting holes to establish the bottom unit elevation.*

3. Each 2-Post Mounting bracket has four (4) rack mounting bolt holes (Figure 1). Slip the cage nut over the top (first) rack rail mounting hole. Repeat for the rail holes corresponding to the 2nd, 3rd, and 4th bracket bolt holes.
4. Attach the 2-Post Slide Bracket on the 2-Post Rack using four (4) PHP, (Pan Head Phillips) 8-32 x 1/4 in. screws (or appropriate fasteners).
5. Repeat Steps 2-3 for the remaining three mounting brackets (Figure 4).

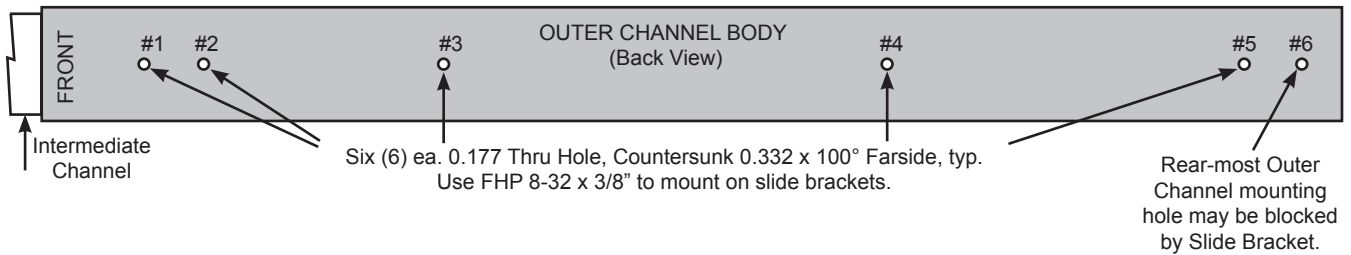
- If more than one module is being installed for the T1000 system, install the remaining mounting bracket kits as described in steps 1-5.

**5. Attach Rail Assemblies to 2-Post Adapter Brackets**

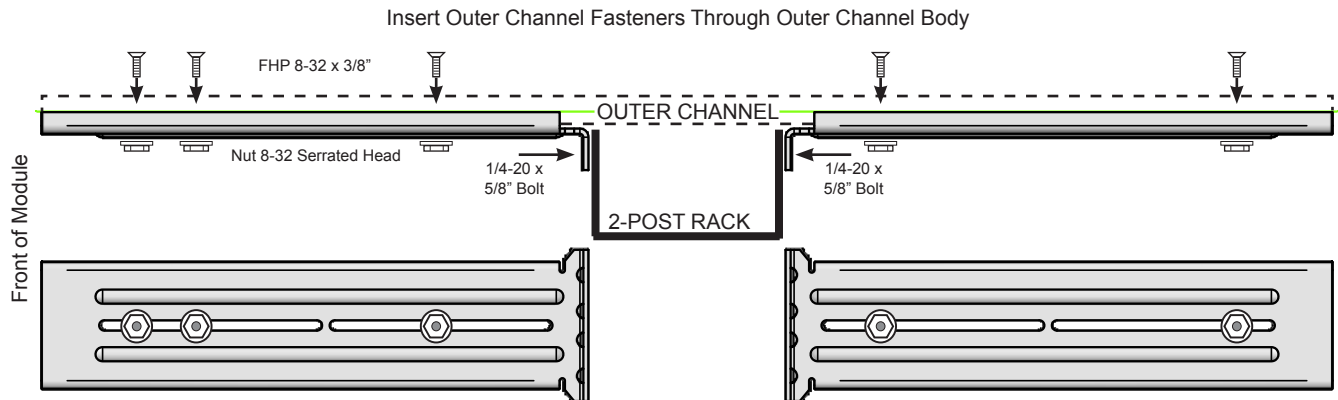
- Orient the Outer Channel Body of the Slide Assembly so the open side is facing inwards, and the front is towards the rack front. Open and fully extend the slide inner channel from the outer channel.

*NOTE: There are six (6) mounting holes available for use. The first two holes, Figure 5 - #1 and #2, are accessible through openings in the Inner Channel when the Inner Channel is fully extended. The Rear-most mounting hole (Figure 5 - #6) may be blocked by the 2-Post mounting bracket.*

- Bolt the Outer Channel Body (370ez-27-11), Figure 1-(3) to the Slide Mount Brackets. (4 places) (See Figure 5) Recommend using holes #1, #2, #4, and #5 in Figure 5.
- Insert the screws through the Outer Channel Body and 2-Post Slide Bracket (Figure 6).
- Secure the four FHP 8-32 x 3/8 in. screws with the 8-32 serrated head nuts from 90400 kit. The nuts screw on from the outside of the 2-Post Slide Bracket. (Figure 6)
- Repeat steps 1-4 for the second slide assembly.



**FIGURE 5: SLIDE OUTER CHANNEL MOUNTING HOLE LOCATIONS**



**FIGURE 6: ATTACH OUTER CHANNEL TO 2-POST SLIDE BRACKET (2 PER MODULE)**

- Repeat steps 1-5 for each module to be installed. (See Figure 7)

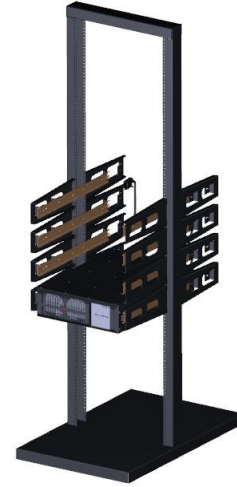
## 6. Install T1000 Modules in Rackmount Slides



**CAUTION:** Battery Modules weight 150 lb. (68 kg). Use lifting aids and proper lifting techniques

NOTE: The T1000 System modules must be arranged top-to-bottom in the following relative order:

- Transformer Module (if present)
  - Power (UPS) Module
  - Battery Module w/Output Panel (if present)
  - Battery Panel w/o Output Panel (if present)
1. Lift the module intended for the bottom slide rail set, and slide the module's E-Z Rails into the extended Slide Middle Member.
  2. Gently slide the module backward until the slides are fully retracted. **FIGURE 7: INSTALL MODULES** (Figure 7)
  3. Repeat steps 1-2 for the module slide rail set immediately above the bottom one.
  4. Continue until all modules have been installed on their slide rails.
  5. Go to **T1000 Installation and Operation Manual - 91074** to continue installation and cabling of the T1000 System.



## Index

### A

- AC input mode 36
- Application 35
- Audible alarm 35, 52, 53

### B

- Backup mode 37, 38
- Battery
  - backup mode 37, 38
  - backup time 37, 38, 39, A-5
  - disposal 7
  - low-voltage tolerances 39
  - recharge tolerances 40
  - recharging 40, 48
  - replacement 5, 59
  - voltage drop 35, 37, 38, 49

### Bypass

- mode 36

### C

- Cable size 24
- capacitors 59
- Cold Start 47
  - Cold Start switch 28
  - Procedure 38
- Common-mode noise 35
- Communication interface 49
- Cooling fan 59

### D

- Data. *See* Data Display Screens, Data Setting Screens

### DB9 Connector

- male pinouts 49

### Dimensional Data 60

### Disposal 7

### E

- Emergency Power Off (EPO) function 24, 37
- Environment 7

### F

- fan 53
- Fault
  - protection functions 53, 54
  - signal 49
- Frequency
  - Warning 27
- Front Panel layout 34

### G

- ground
  - Importance of, 8
- Grounding 9

### H

- humidity 7

### I

- Input Frequency
  - warning 27
- Input Voltage A-5
- Inspection 7

Installation 10  
    rackmount arrangement 20  
    tower arrangement 12, 13

Installation Precautions 8

Interface  
    communications 49, 50

## **L**

labels, warning 3

Layout, Back Panel 22  
    Battery Module 23  
    Power Module 22  
    Transformer Module 24

Layout, Front Panel 28  
    Cold Start Button 28

    Display 28

Lifetime  
    battery 59  
    capacitors, Aluminum electrolytic 59  
    fan, cooling 59  
    fuses 59

Low Voltage Tolerance 39

## **M**

MAIN tab 34  
maximum ambient operating temperature 5

Mode  
    AC Input 36

## **N**

Normal input power supply 49

## **O**

Operation modes. *See* Modes

output disconnect 5

Overvoltage

    DC 53  
    output 52

## **P**

Power Conditioning 35

Power factor  
    output, rated load 39

Power failure signal 49

Precautions 27

Protection System 52

## **R**

Recharge Time 40

RECORDS tab  
    Fault messages 54

remote contacts interface 49

Remote Switch 24

Restrictions on UPS use 27

## **S**

Safety instructions 1, 5

Shipping Weight 60

Shutdown voltage 39

Signal Function  
    RS-232C 49

Signal Words 2

Size  
    wire 24

Specifications A-1

Startup, Initial 32

Storage 7

## T

Theory of Operation 35

torque, tightening 24

Touchscreen

    menu tree 34

## U

UPS

    Discharge Process 37, 38, 39

UPS functional overview 35

UPS stop signal input 49

## V

ventilation 27

Volume, Buzzer. *See* Buzzer Volume

## W

warning labels 3

Warranty c, d, 7

Weights, shipping 60

Weights, UPS 60







# TOSHIBA

**TOSHIBA INTERNATIONAL CORPORATION  
SOCIAL INFRASTRUCTURE SYSTEMS GROUP  
POWER ELECTRONICS DIVISION**

13131 West Little York Road, Houston, Texas 77041  
Tel (713) 466-0277 Fax. (713) 896-5212  
US (855) 803-7087 Canada (800) 872-2192

*[www.toshiba.com/tic/industrial/uninterruptible-power-systems](http://www.toshiba.com/tic/industrial/uninterruptible-power-systems)*

Printed in the U.S.A.