

Description:

This N-Channel MOSFET uses advanced trench technology and design to provide excellent $R_{DS(on)}$ with low gate charge. It can be used in a wide variety of applications.

Features:

- 1) $V_{DS}=30V, I_D=10.3A, R_{DS(ON)}<8m\ \Omega$ @ $V_{GS}=10V$
- 2) Low gate charge.
- 3) Green device available.
- 4) Advanced high cell density trench technology for ultra low $R_{DS(ON)}$.
- 5) Excellent package for good heat dissipation.

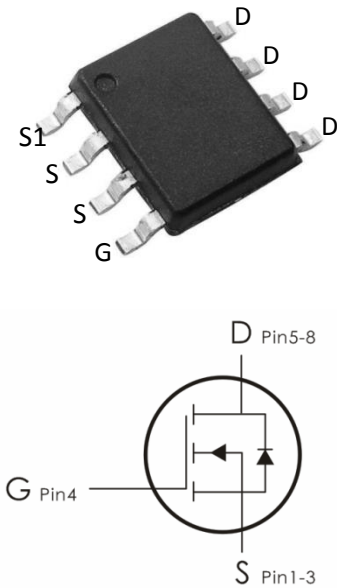

Absolute Maximum Ratings: ($T_C=25^\circ\text{C}$ unless otherwise noted)

Symbol	Parameter	Ratings	Units
V_{DS}	Drain-Source Voltage	30	V
V_{GS}	Gate-Source Voltage	± 20	V
I_D	Drain Current -Continuous ¹ ($T_A=25^\circ\text{C}$)	10.3	A
	Drain Current -Continuous ¹ ($T_A=70^\circ\text{C}$)	8.2	
I_{DM}	Drain Current – Pulsed ²	42	
E_{AS}	Single Pulse Avalanche Energy ³	61	mJ
I_{AS}	Avalanche Current	35	A
P_D	Power Dissipation ⁴ ($T_A=25^\circ\text{C}$)	1.5	W
T_J, T_{STG}	Operating and Storage Junction Temperature Range	-55 to +150	$^\circ\text{C}$

Thermal Characteristics:

Symbol	Parameter	Max	Units
$R_{\theta JC}$	Thermal Resistance, Junction to Case ¹	36	$^\circ\text{C}/\text{W}$
$R_{\theta JA}$	Thermal Resistance, Junction to Ambient ¹	85	

Electrical Characteristics: ($T_C=25^{\circ}\text{C}$ unless otherwise noted)

Symbol	Parameter	Conditions	Min	Typ	Max	Units
Off Characteristics						
BV_{DSS}	Drain-Source Breakdown Voltage	$V_{GS}=0V, I_D=250\ \mu A$	30	---	---	V
I_{DSS}	Drain-Source Leakage Current	$V_{DS}=24V, V_{GS}=0V, T_J=25^{\circ}\text{C}$	---	---	1	μA
		$V_{DS}=24V, V_{GS}=0V, T_J=55^{\circ}\text{C}$	---	---	5	μA
I_{GSS}	Gate-Source Leakage Current	$V_{GS}=\pm 20V, V_{DS}=0V$	---	---	± 100	nA
On Characteristics³						
$V_{GS(th)}$	GATE-Source Threshold Voltage	$V_{GS}=V_{DS}, I_D=250\ \mu A$	1.2	1.5	2.5	V
$R_{DS(on)}$	Static Drain-Source On Resistance ²	$V_{GS}=10V, I_D=10A$	---	7	8	$m\ \Omega$
		$V_{GS}=4.5V, I_D=8A$	---	11	14	$m\ \Omega$
G_{FS}	Forward Transconductance	$V_{DS}=5V, I_D=10A$	---	5.8	---	S
Dynamic Characteristics						
C_{iss}	Input Capacitance	$V_{DS}=15V, V_{GS}=0V, f=1\text{MHz}$	---	1300	1840	pF
C_{oss}	Output Capacitance		---	160	225	
C_{rss}	Reverse Transfer Capacitance		---	130	180	
Switching Characteristics						
$t_{d(on)}$	Turn-On Delay Time	$V_{DD}=15V, I_D=10A$ $R_G=3.3\ \Omega, V_{GS}=10V$	---	6.2	12.4	ns
t_r	Rise Time		---	59	106	ns
$t_{d(off)}$	Turn-Off Delay Time		---	27.6	55	ns
t_f	Fall Time		---	8.4	16.8	ns
Q_g	Total Gate Charge	$V_{GS}=4.5V, V_{DS}=15V,$ $I_D=10A$	---	12.6	17.6	nC
Q_{gs}	Gate-Source Charge		---	4.2	5.9	nC
Q_{gd}	Gate-Drain "Miller" Charge		---	5.1	7.1	nC
R_G	Gate Resistance	Gate Resistance	---	2.2	3.8	Ω

Drain-Source Diode Characteristics						
V_{SD}	Source-Drain Diode Forward Voltage ²	V _{GS} =0V, I _S =1A, T _J =25°C	---	---	1.2	V
I_S	Continuous Source Current ^{1,5}	V _G =V _D =0V, Force Current	---	---	10.3	A
I_{SM}	Pulsed Source Current ^{2,5}		---	---	42	A
T_{rr}	Body Diode Reverse Recovery Time	I _F =10A, di/dt=100A/μs, T _J =25°C	---	12.5	---	Ns
Q_{rr}	Body Diode Reverse Recovery Charge		---	5	---	Nc

Notes:

1. The data tested by surface mounted on a 1 inch² FR-4 board with 2OZ copper.
2. The data tested by pulsed, pulse width ≤ 300us, duty cycle ≤ 2%
3. The EAS data shows Max. rating. The test condition is V_{DD}=25V, V_{GS}=10V, L=0.1mH, I_{AS}=35A
4. The power dissipation is limited by 150°C junction temperature
5. The data is theoretically the same as I_D and I_{DM}, in real applications, should be limited by total power dissipation.

Typical Characteristics: (T_C=25°C unless otherwise noted)

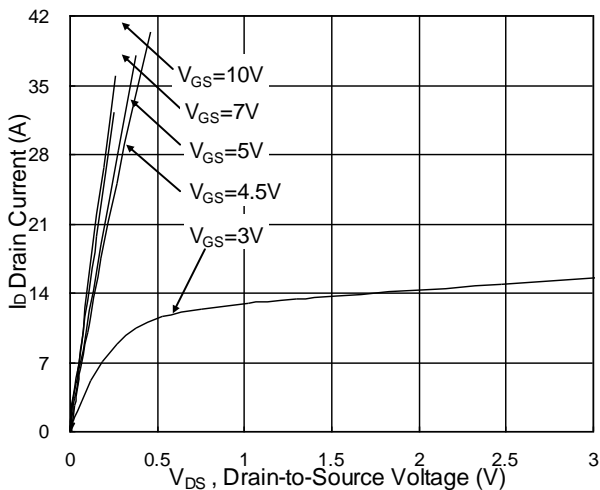

Fig.1 Typical Output Characteristics

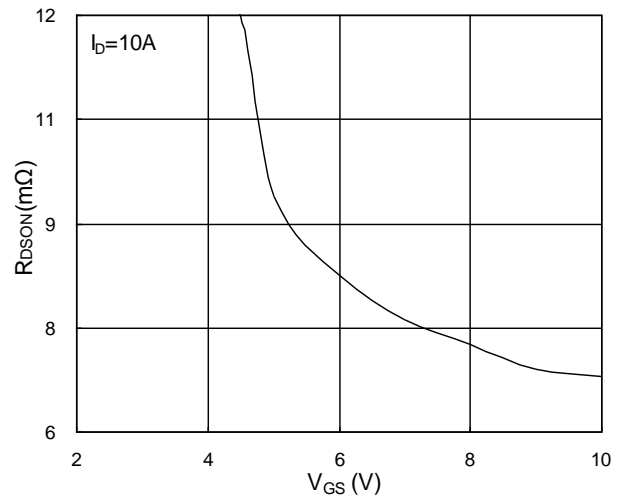

Fig.2 On-Resistance vs. Gate-Source

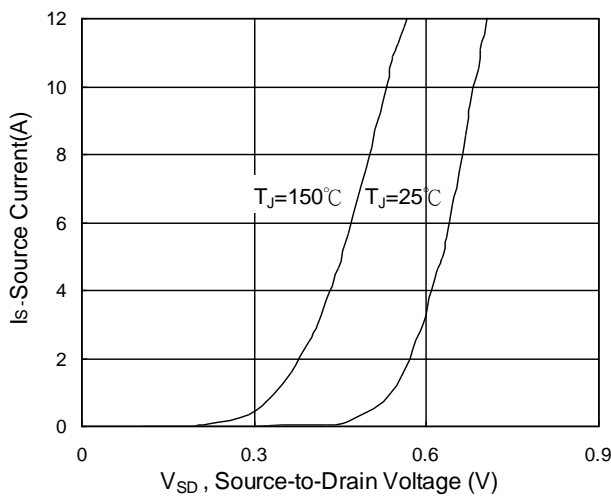

Fig.3 Forward Characteristics of reverse

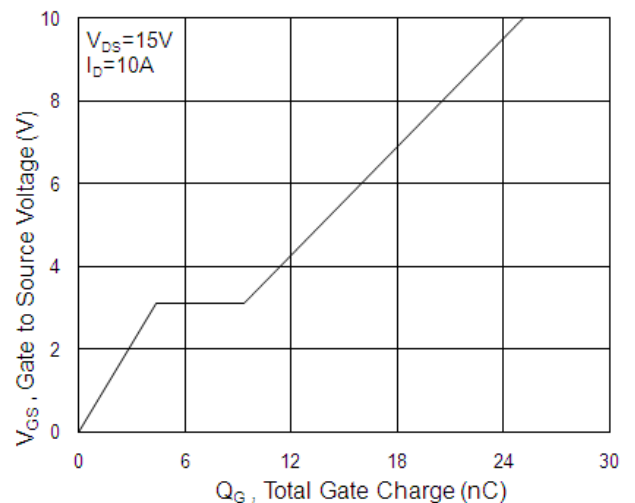

Fig.4 Gate-Charge Characteristics

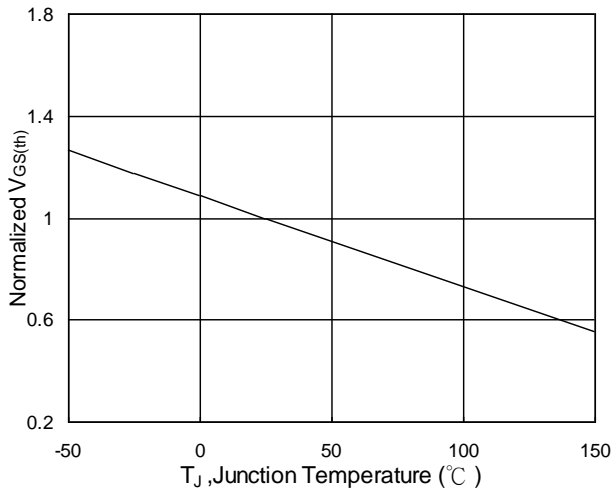

Fig.5 Normalized $V_{GS(th)}$ vs. T_J

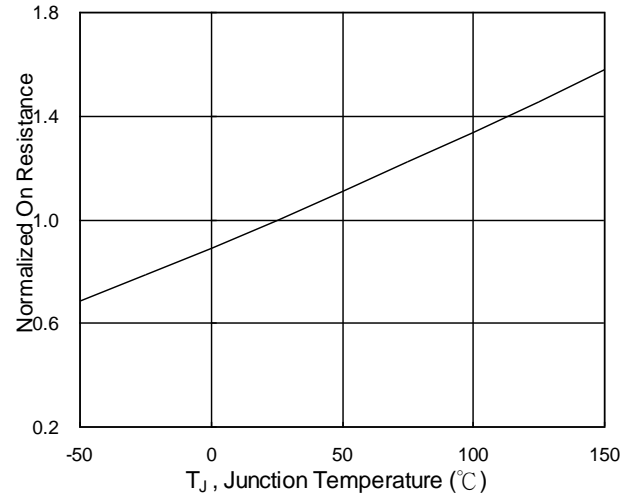

Fig.6 Normalized $R_{DS(on)}$ vs. T_J

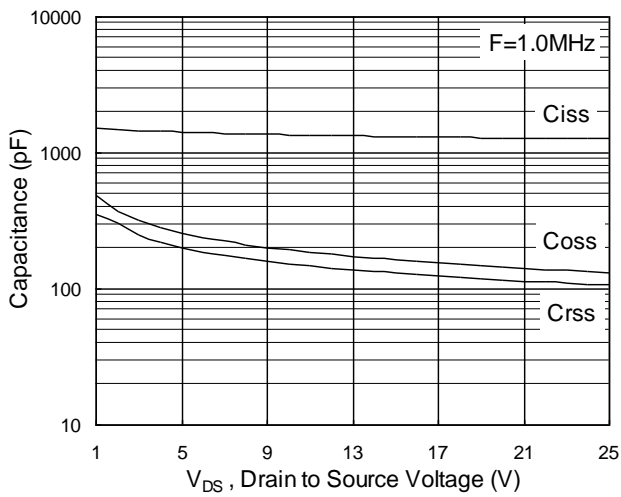

Fig.7 Capacitance

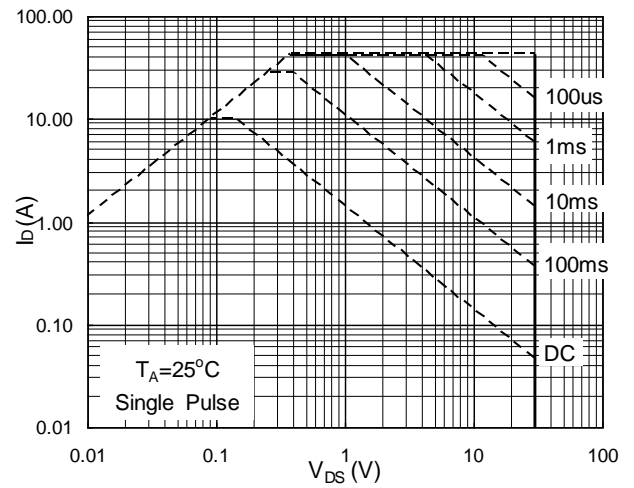

Fig.8 Safe Operating Area

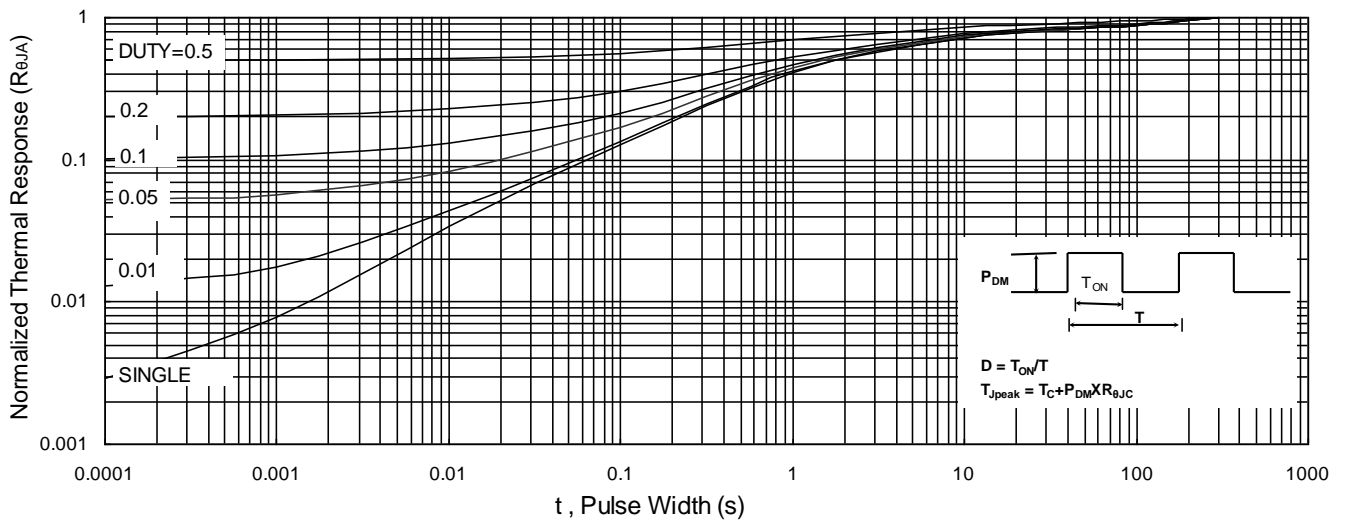

Fig.9 Normalized Maximum Transient Thermal Impedance

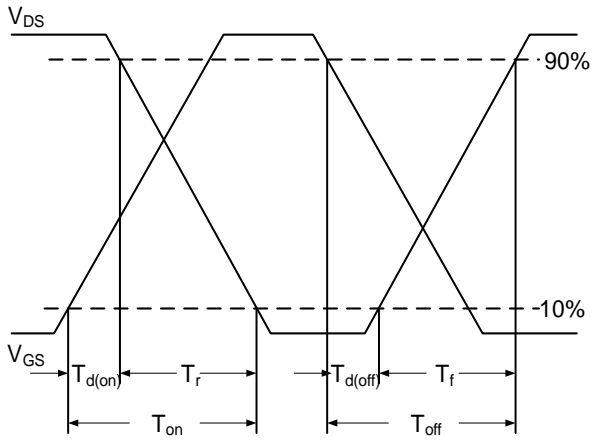

Fig.10 Switching Time Waveform

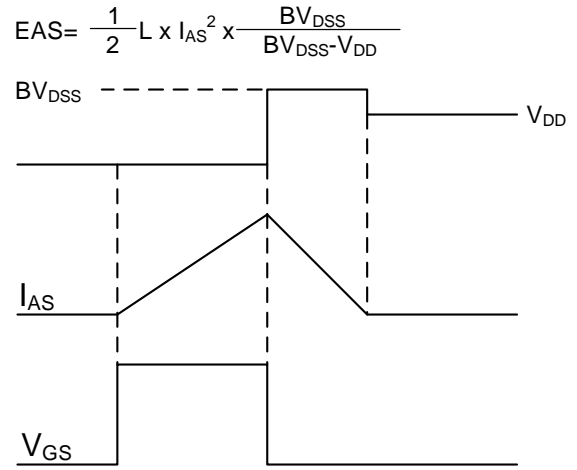

Fig.11 Unclamped Inductive Switching Waveform



0086-0755-8278-9056

www.doingter.cn