

# NHD-C0220BiZ-FS(RGB)-FBW-3VM

## COG (Chip-On-Glass) Character Liquid Crystal Display Module

NHD-	Newhaven Display
C0220-	COG, 2 Lines x 20 Characters
BiZ-	Model, I <sup>2</sup> C Interface
F-	Transflective
S(RGB)-	Side LED Backlights – Red, Green, and Blue
F-	FSTN (+)
B-	6:00 Optimal View
W-	Wide Temperature
3V-	3.3V LCD
M-	Mounting Holes
	<b>RoHS Compliant</b>

**Newhaven Display International, Inc.**

2511 Technology Drive, Suite 101

Elgin IL, 60124

Ph: 847-844-8795

Fax: 847-844-8796

[www.newhavendisplay.com](http://www.newhavendisplay.com)

[nhtech@newhavendisplay.com](mailto:nhtech@newhavendisplay.com)

[nhsales@newhavendisplay.com](mailto:nhsales@newhavendisplay.com)

## Document Revision History

Revision	Date	Description	Changed by
0	7/8/09	Initial Release	CL
1	7/10/09	Mechanical Drawing updated	BE
2	9/8/09	Backlight supply current	BE
3	10/9/09	Updated Electrical Characteristics	MC
4	12/9/09	Updated Backlight Power supply and Current	MC
5	5/27/11	Display character address code updated	AK
6	6/13/11	Electrical characteristics updated	AK
7	6/23/14	Mechanical, Electrical & Optical Characteristics Updated	ML
8	5/24/17	Mechanical, Electrical Characteristics Updated	SB

## Functions and Features

- 2 lines x 20 characters
- Built-in ST7036i controller with I<sup>2</sup>C interface
- 3.3V power supply
- 1/16 duty, 1/5 bias
- Built-in DC supply for VLCD (requires 2 external capacitors)

# Mechanical Drawing

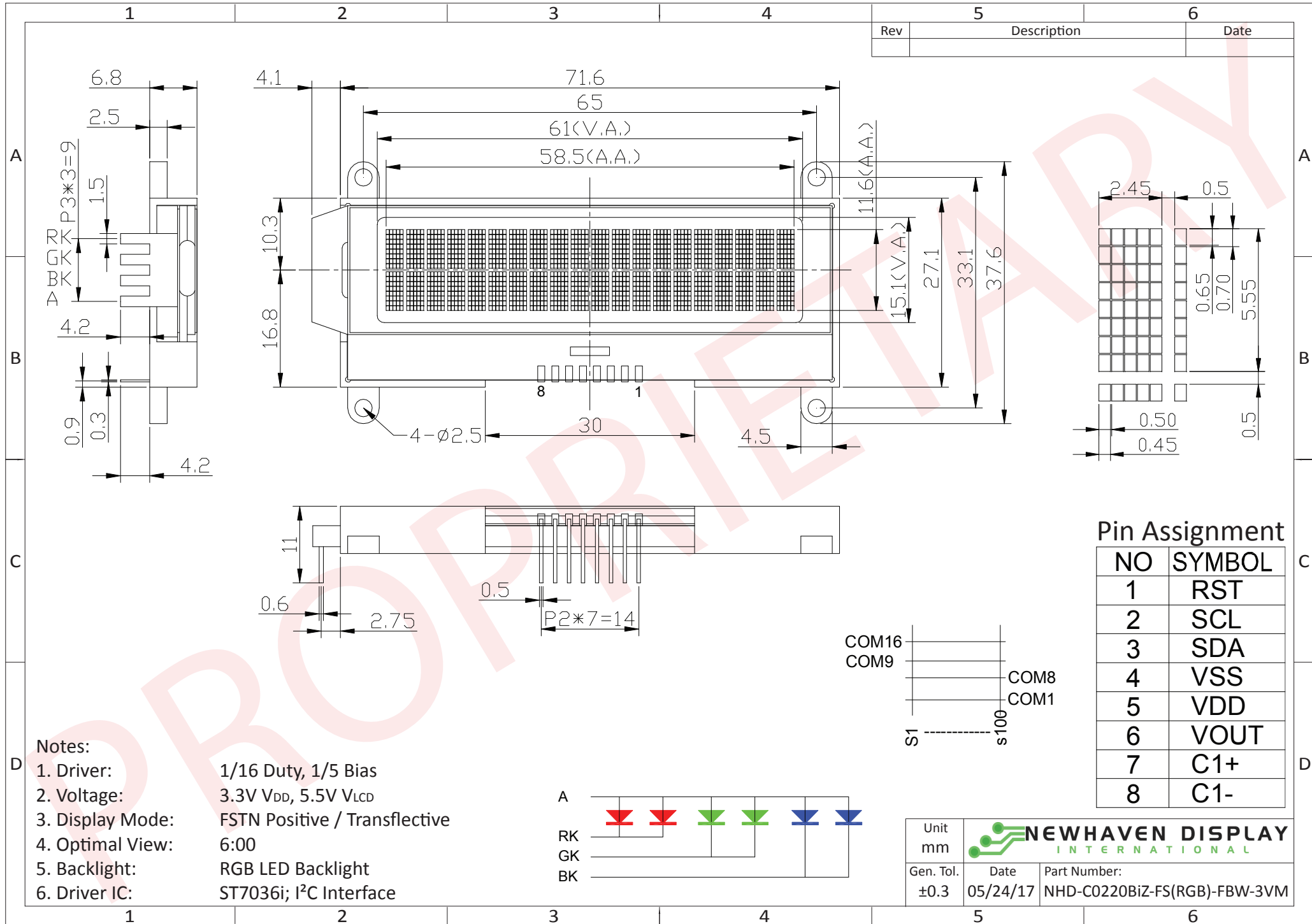

The information contained herein is the exclusive property of Newhaven Display International, Inc. and shall not be copied, reproduced, and/or disclosed in any format without permission.

## Pin Description and Wiring Diagram

Pin No.	Symbol	External Connection	Function Description
1	RST	MPU	Active LOW Reset signal
2	SCL	MPU	Serial Clock signal (requires pull-up resistor)
3	SDA	MPU	Serial Data signal (requires pull-up resistor)
4	V <sub>SS</sub>	Power Supply	Ground
5	V <sub>DD</sub>	Power Supply	Supply Voltage for Logic (+3.3V)
6	V <sub>OUT</sub>	CAP	Connect 1 $\mu$ F cap to VSS or VDD
7	C1+	CAP	Connect 0.47-2.2 $\mu$ F cap to PIN8
8	C1-	CAP	Connect 0.47-2.2 $\mu$ F cap to PIN7

**Recommended LCD connector:** N/A, solder directly into PCB

**Backlight connector:** 3.0mm pitch pins, solder directly into PCB **Mates with:** ---

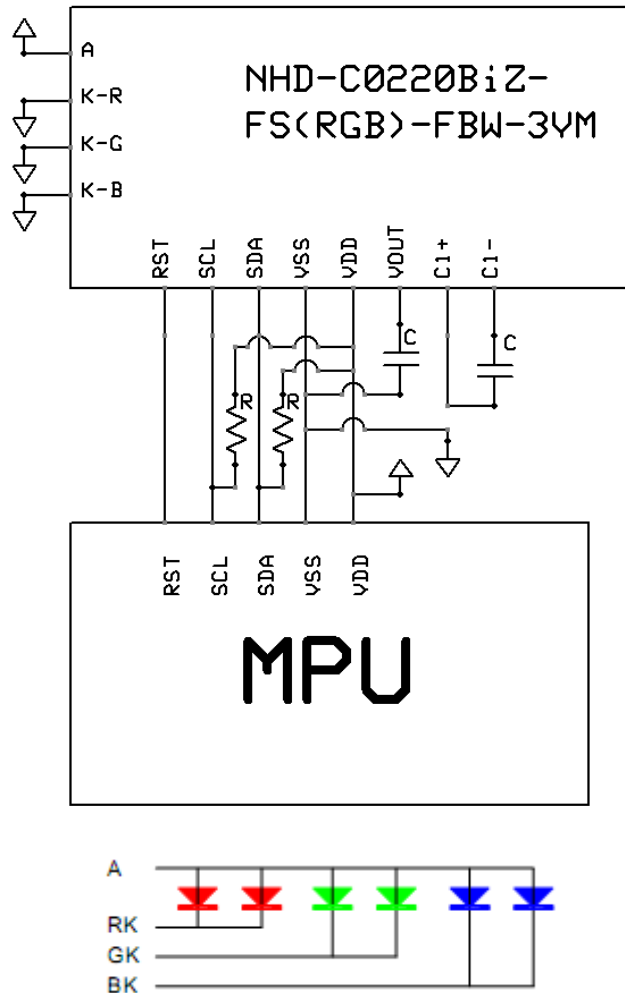

Capacitance 0.47 $\mu$ F~2.2 $\mu$ F; Recommended value = 1 $\mu$ F  
Recommended Resistor: 10k $\Omega$

## Electrical Characteristics

Item	Symbol	Condition	Min.	Typ.	Max.	Unit
Operating Temperature Range	T <sub>OP</sub>	Absolute Max	-20	-	+70	°C
Storage Temperature Range	T <sub>ST</sub>	Absolute Max	-30	-	+80	°C
Supply Voltage	V <sub>DD</sub>	-	3.0	3.3	3.6	V
Supply Current	I <sub>DD</sub>	V <sub>DD</sub> = 3.3V T <sub>OP</sub> = 25°C	0.2	0.5	1.5	mA
Supply for LCD (contrast)	V <sub>LCD</sub>		5.3	5.5	5.7	V
"H" Level input	V <sub>IH</sub>	-	0.7 * V <sub>DD</sub>	-	V <sub>DD</sub>	V
"L" Level input	V <sub>IL</sub>	-	V <sub>SS</sub>	-	0.8	V
"H" Level output	V <sub>OH</sub>	-	0.7 * V <sub>DD</sub>	-	V <sub>DD</sub>	V
"L" Level output	V <sub>OL</sub>	-	V <sub>SS</sub>	-	0.8	V
Backlight Supply Current – RED	I <sub>R</sub>	-	-	20	30	mA
Backlight Supply Voltage – RED	V <sub>R</sub>	I <sub>R</sub> = 20mA	1.7	1.9	2.1	V
Backlight Supply Current – GREEN	I <sub>G</sub>	-	-	30	40	mA
Backlight Supply Voltage – GREEN	V <sub>G</sub>	I <sub>G</sub> = 30mA	2.7	2.9	3.1	V
Backlight Supply Current – BLUE	I <sub>B</sub>	-	-	30	40	mA
Backlight Supply Voltage – BLUE	V <sub>B</sub>	I <sub>B</sub> = 30mA	2.7	2.9	3.1	V

## Optical Characteristics

Item	Symbol	Condition	Min.	Typ.	Max.	Unit
Optimal Viewing Angles	Top	CR ≥ 2	-	40	-	°
	Bottom		-	60	-	°
	Left		-	60	-	°
	Right		-	60	-	°
Contrast Ratio	CR	-	2	5	-	-
Response Time	Rise	T <sub>OP</sub> = 25°C	-	150	250	ms
	Fall		-	200	300	ms

## Controller Information

Built-in ST7036i controller.

Please download specification at [http://www.newhavendisplay.com/app\\_notes/ST7036.pdf](http://www.newhavendisplay.com/app_notes/ST7036.pdf)

## DDRAM Address

1	2	3	4	5	6	7	8	9	10	11	12	13	14	15	16	17	18	19	20
00	01	02	03	04	05	06	07	08	09	0A	0B	0C	0D	0E	0F	10	11	12	13
40	41	42	43	44	45	46	47	48	49	4A	4B	4C	4D	4E	4F	50	51	52	53

# Slave Address = 0x78

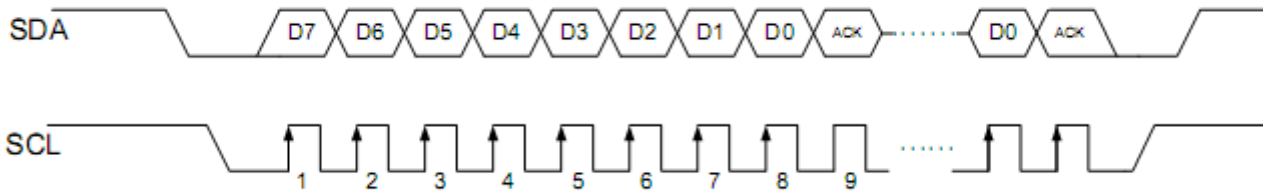
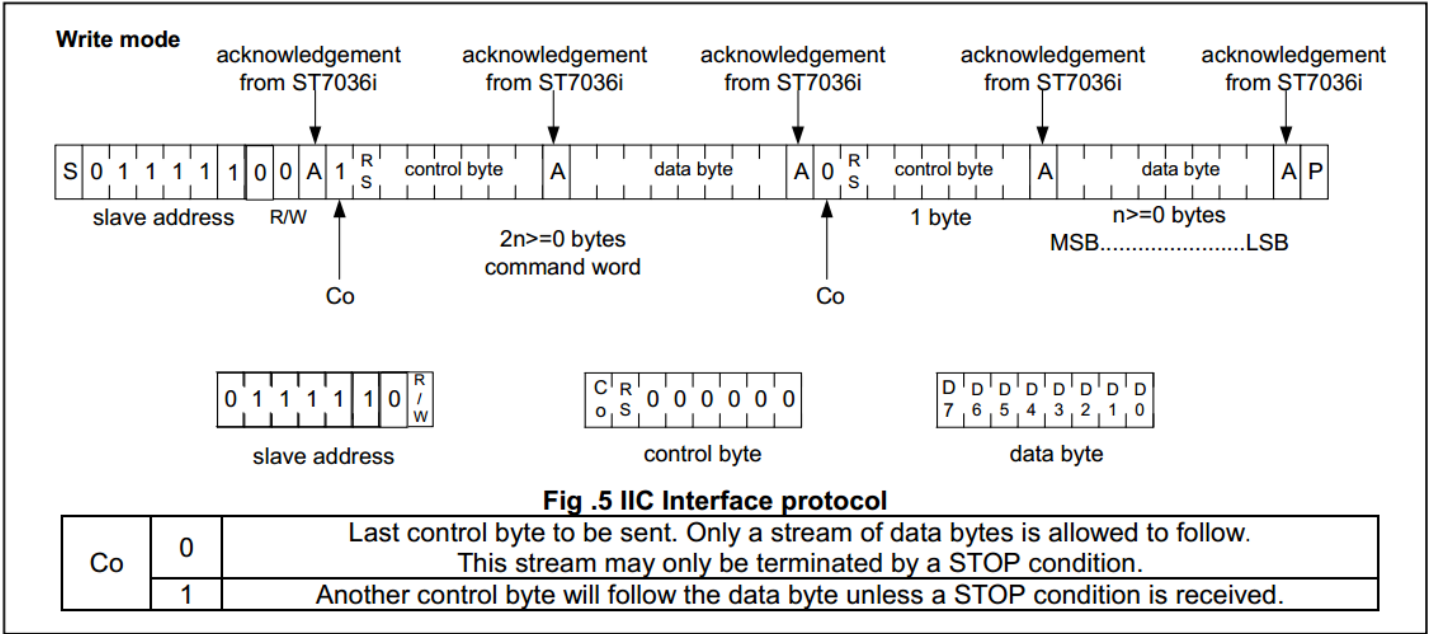

## Table of Commands

Instruction	Instruction Code										Description	
	RS	R/W	DB7	DB6	DB5	DB4	DB3	DB2	DB1	DB0		
Clear Display	0	0	0	0	0	0	0	0	0	0	1	Write "20H" to DDRAM. and set DDRAM address to "00H" from AC
Return Home	0	0	0	0	0	0	0	0	0	1	x	Set DDRAM address to "00H" from AC and return cursor to its original position if shifted. The contents of DDRAM are not changed.
Entry Mode Set	0	0	0	0	0	0	0	0	1	I/D	S	Sets cursor move direction and specifies display shift. These operations are performed during data write and read.
Display ON/OFF	0	0	0	0	0	0	0	1	D	C	B	D=1:entire display on C=1:cursor on B=1:cursor position on
Function Set	0	0	0	0	1	DL	N	DH	IS2	IS1		DL: interface data is 8/4 bits N: number of line is 2/1 DH: double height font IS[2:1]: instruction table select
Set DDRAM Address	0	0	1	AC6	AC5	AC4	AC3	AC2	AC1	AC0		Set DDRAM address in address counter
Read Busy Flag and Address	0	1	BF	AC6	AC5	AC4	AC3	AC2	AC1	AC0		Whether during internal operation or not can be known by reading BF. The contents of address counter can also be read.
Write Data to RAM	1	0	D7	D6	D5	D4	D3	D2	D1	D0		Write data into internal RAM (DDRAM/CGRAM/ICONRAM)
Read Data from RAM	1	1	D7	D6	D5	D4	D3	D2	D1	D0		Read data from internal RAM (DDRAM/CGRAM/ICONRAM)

Instruction table 0(IS[2:1]=[0,0])											
Cursor or Display Shift	0	0	0	0	0	1	S/C	R/L	X	X	S/C and R/L: Set cursor moving and display shift control bit, and the direction, without changing DDRAM data.
Set CGRAM	0	0	0	1	AC5	AC4	AC3	AC2	AC1	AC0	Set CGRAM address in address counter

Instruction table 1(IS[2:1]=[0,1])											
Bias Set	0	0	0	0	0	1	BS	1	0	FX	BS=1:1/4 bias BS=0:1/5 bias FX: fixed on high in 3-line application and fixed on low in other applications.
Set ICON Address	0	0	0	1	0	0	AC3	AC2	AC1	AC0	Set ICON address in address counter.
Power/ICON Control/ Contrast Set	0	0	0	1	0	1	Ion	Bon	C5	C4	Ion: ICON display on/off Bon: set booster circuit on/off C5,C4: Contrast set for internal follower mode.
Follower Control	0	0	0	1	1	0	Fon	Rab2	Rab1	Rab0	Fon: set follower circuit on/off Rab2~0: select follower amplified ratio.
Contrast Set	0	0	0	1	1	1	C3	C2	C1	C0	Contrast set for internal follower mode.

Instruction table 2(IS[2:1]=[1,0])											
Double Height Position Select	0	0	0	0	0	1	UD	X	x	x	UD: Double height position select
Reserved	0	0	0	1	X	X	X	X	X	X	Do not use (reserved for test)



## Timing Characteristics

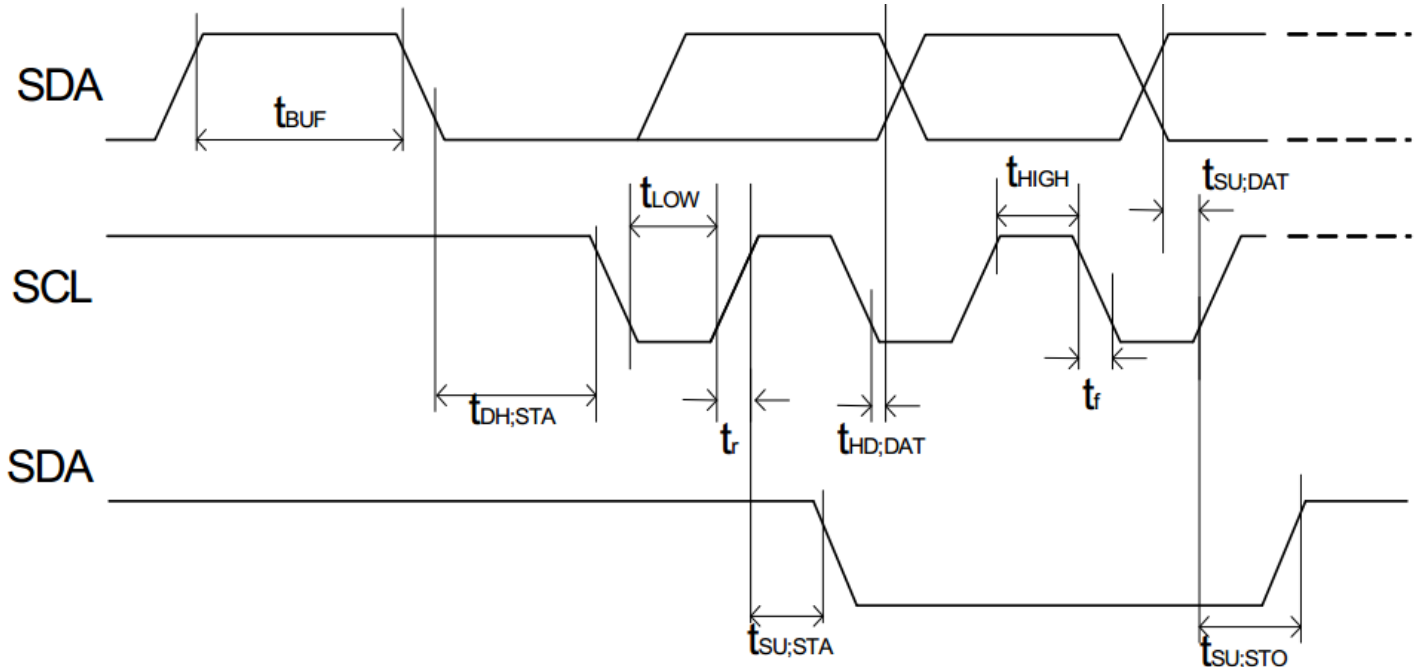

Item	Signal	Symbol	Condition	VDD=2.7 to 4.5V Rating		VDD=4.5 to 5.5V Rating		Units
				Min.	Max.	Min.	Max.	
SCL clock frequency	SCL	$f_{SCLK}$	—	DC	300K	DC	400	kHz
SCL clock low period		$t_{LOW}$	—	2.5	—	1.3	—	$\mu s$
SCL clock high period		$t_{HIGH}$	—	0.6	—	0.6	—	$\mu s$
Data set-up time	SDA	$t_{SU,DAT}$	—	1800	—	700	—	ns
Data hold time		$t_{HD,DAT}$	—	0	—	0	0.5	$\mu s$
SCL,SDA rise time	SCL, SDA	$t_r$	—	$20+0.1C_b$	300	$20+0.1C_b$	300	ns
SCL,SDA fall time		$t_r$	—	$20+0.1C_b$	300	$20+0.1C_b$	300	
Capacitive load represent by each bus line		$C_b$	—	—	400	—	400	pf
Setup time for a repeated START condition	SDA	$t_{SU,STA}$	—	0.6	—	0.6	—	$\mu s$
Start condition hold time		$t_{HD,STA}$	—	1.8	—	1.0	—	$\mu s$
Setup time for STOP condition		$t_{SU,STO}$	—	0.6	—	0.6	—	$\mu s$
Bus free time between a Stop and START condition	SCL	$t_{BUF}$	—	1.3	—	1.3	—	$\mu s$

Built-in Font Table (OPR1 = 0, OPR2 = 0)

b7-b4 b3-b0	0000	0001	0010	0011	0100	0101	0110	0111	1000	1001	1010	1011	1100	1101	1110	1111
0000	█	█	█	0	1	2	3	4	5	6	7	8	9	█	█	█
0001	█	█	!	!	!	!	!	!	!	!	!	!	!	!	!	!
0010	█	█	"	"	"	"	"	"	"	"	"	"	"	"	"	"
0011	█	█	#	#	#	#	#	#	#	#	#	#	#	#	#	#
0100	█	█	\$	\$	\$	\$	\$	\$	\$	\$	\$	\$	\$	\$	\$	\$
0101	█	█	%	%	%	%	%	%	%	%	%	%	%	%	%	%
0110	█	█	&	&	&	&	&	&	&	&	&	&	&	&	&	&
0111	█	█	'	'	'	'	'	'	'	'	'	'	'	'	'	'
1000	█	█	(	(	(	(	(	(	(	(	(	(	(	(	(	(
1001	█	█	)	)	)	)	)	)	)	)	)	)	)	)	)	)
1010	█	█	*	*	*	*	*	*	*	*	*	*	*	*	*	*
1011	█	█	+	+	+	+	+	+	+	+	+	+	+	+	+	+
1100	█	█	,	,	,	,	,	,	,	,	,	,	,	,	,	,
1101	█	█	-	-	-	-	-	-	-	-	-	-	-	-	-	-
1110	█	█	.	.	.	.	.	.	.	.	.	.	.	.	.	.
1111	█	█	/	/	/	/	/	/	/	/	/	/	/	/	/	/

## Example Initialization Program

```

/*****
*           Initialization For ST7036i           *
*****/
void init_LCD()
{
I2C_Start();
I2C_out(Slave);//Slave=0x78
I2C_out(Comsend);//Comsend = 0x00
I2C_out(0x38);
delay(10);
I2C_out(0x39);
delay(10);
I2C_out(0x14);
I2C_out(0x78);
I2C_out(0x5E);
I2C_out(0x6D);
I2C_out(0x0C);
I2C_out(0x01);
I2C_out(0x06);
delay(10);
I2C_Stop();
}
/*****/

/*****
*           Output command or data via I2C           *
*****/
void I2C_out(unsigned char j)           //I2C Output
{
    int n;
    unsigned char d;
    d=j;
    for(n=0;n<8;n++){
        if((d&0x80)==0x80)
            SDA=1;
        else
            SDA=0;
        d=(d<<1);
        SCL = 0;
        SCL = 1;
        SCL = 0;
    }
    SCL = 1;
    while(SDA==1){
        SCL=0;
        SCL=1;
    }
    SCL=0;
}
/*****/

```

```

/*****
*           I2C Start                               *
*****/
void I2C_Start(void)
{
    SCL=1;
    SDA=1;
    SDA=0;
    SCL=0;
}
/*****/

/*****
*           I2C Stop                               *
*****/
void I2C_Stop(void)
{
    SDA=0;
    SCL=0;
    SCL=1;
    SDA=1;
}
/*****/

/*****
*           Send string of ASCII data to LCD       *
*****/
void Show(unsigned char *text)
{
    int n,d;
    d=0x00;
    I2C_Start();
    I2C_out(Slave); //Slave=0x78
    I2C_out(Datasend); //Datasend=0x40
    for(n=0;n<20;n++){
        I2C_out(*text);
        ++text;
    }
    I2C_Stop();
}
/*****/
/*****/
/*****/

```

## Quality Information

Test Item	Content of Test	Test Condition	Note
High Temperature storage	Endurance test applying the high storage temperature for a long time.	+80°C , 96hrs	2
Low Temperature storage	Endurance test applying the low storage temperature for a long time.	-30°C , 96hrs	1,2
High Temperature Operation	Endurance test applying the electric stress (voltage & current) and the high thermal stress for a long time.	+70°C , 96hrs	2
Low Temperature Operation	Endurance test applying the electric stress (voltage & current) and the low thermal stress for a long time.	-20°C , 96hrs	1,2
High Temperature / Humidity Operation	Endurance test applying the electric stress (voltage & current) and the high thermal with high humidity stress for a long time.	+60°C , 90% RH , 96hrs	1,2
Thermal Shock resistance	Endurance test applying the electric stress (voltage & current) during a cycle of low and high thermal stress.	-20°C,30min -> 25°C,5min -> 70°C,30min = 1 cycle 10 cycles	
Vibration test	Endurance test applying vibration to simulate transportation and use.	10-55Hz , 15mm amplitude. 60 sec in each of 3 directions X,Y,Z For 15 minutes	3
Static electricity test	Endurance test applying electric static discharge.	VS=800V, RS=1.5kΩ, CS=100pF One time	

**Note 1:** No condensation to be observed.

**Note 2:** Conducted after 4 hours of storage at 25°C, 0%RH.

**Note 3:** Test performed on product itself, not inside a container.

## Precautions for using LCDs/LCMs

See Precautions at [www.newhavendisplay.com/specs/precautions.pdf](http://www.newhavendisplay.com/specs/precautions.pdf)

## Warranty Information

See Terms & Conditions at [http://www.newhavendisplay.com/index.php?main\\_page=terms](http://www.newhavendisplay.com/index.php?main_page=terms)