

Rev	AWO #	Description	Date	Appr
-		RELEASED	6/29/11	

APPROVED: \_\_\_\_\_  
 DATE: \_\_\_\_\_ TITLE: \_\_\_\_\_

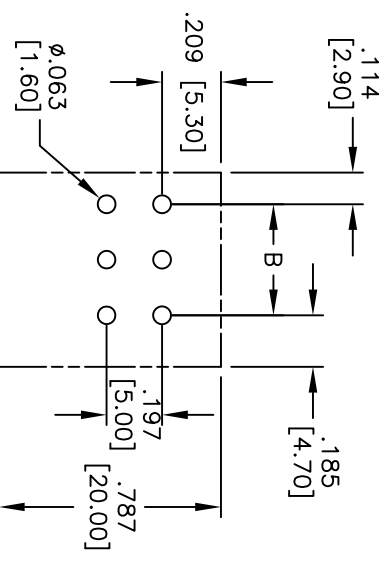
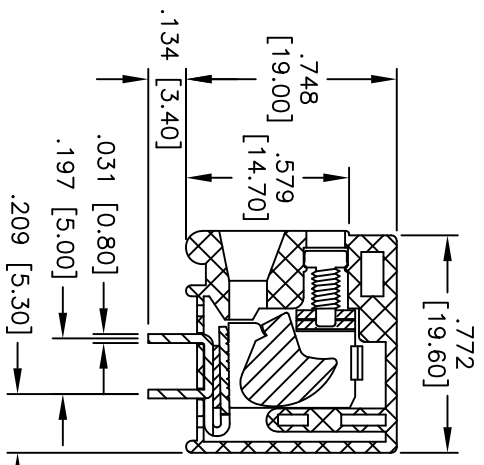
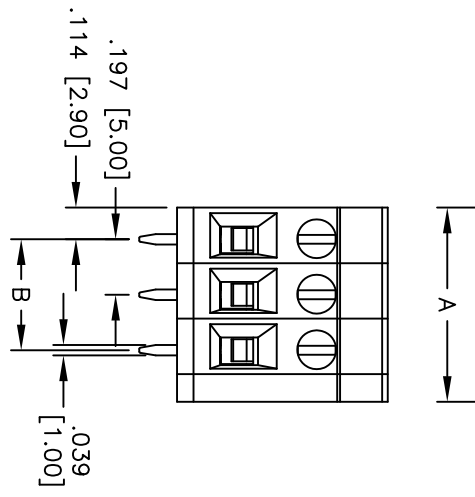
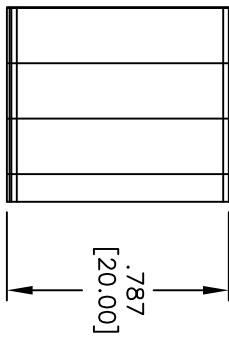

RECOMMENDED PCB LAYOUT

**SPECIFICATIONS:**

- Material: Thermoplastic, rated UL 94V-0
- Insulator color: Green
- Screw: M2.5, Steel, Zn plated.
- Contact: Brass, Tin plated.
- Electrical:
  - Operation voltage: 300 VAC
  - Current rating: 20 Amps
  - Withstanding Voltage: 1.6KV
- Mechanical:
  - Wire strip length: 10-11mm
  - Torque (Lb-In): 2.4
  - Wire Range: 12-22 Awg
- Environmental:
  - Operating temperature: -40°C to +115°C
  - Lead free, RoHS compliant.
  - Recommended soldering temp: 235°C for 5 sec.

Poles: 1 thru 24  
 A = .197 [5.00] X No. of Positions + .098 [2.50]  
 B = .197 [5.00] X No. of Spaces

UNLESS OTHERWISE SPECIFIED  
 ALL DIMENSIONS ARE MM [INCHES]  
 TOLERANCES: EXCEPT AS NOTED

.X	± .10	ØXX	± .10
.XX	± .020	ØXXX	± .015
.XXX	± .015	ØXXXX	± .010

APPROVALS

DRAWN	DY	6/29/11
CHECKED		
APPROVED		

**ADAM TECH**  
 909 Rahway Avenue, Union, NJ 07083  
 Phone: 908-687-5000 Fax: 908-687-5710

TITLE: EURO BLOCK, 197 [5.00] PITCH



SIZE	PART NO.	REV.
X	EB14-XX-1	-
REF: S00007T	SCALE: NTS	SHEET 1 OF 1