



# UF3N30Z

Power MOSFET

## 3A, 300V N-CHANNEL POWER MOSFET

### DESCRIPTION

The UTC **UF3N30Z** is an N-channel enhancement mode Power MOSFET using UTC' s advanced technology to provide customers with a minimum on-state resistance, low gate charge and superior switching performance.

### FEATURES

- \*  $R_{DS(ON)} < 2\Omega$  @  $V_{GS}=10V, I_D=3A$
- \* High switching speed
- \* Typically 4nC low gate charge
- \* 100% avalanche tested

### SYMBOL

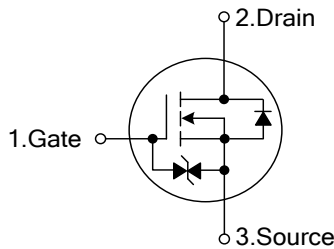

### ORDERING INFORMATION

Ordering Number		Package	Pin Assignment			Packing
Lead Free	Halogen Free		1	2	3	
UF3N30ZL-TM3-R	UF3N30ZG-TM3-R	TO-251	G	D	S	Tape Reel
UF3N30ZL-TN3-T	UF3N30ZG-TN3-T	TO-252	G	D	S	Tube
UF3N30ZL-TN3-R	UF3N30ZG-TN3-R	TO-252	G	D	S	Tape Reel

Note: Pin Assignment: G: Gate D: Drain S: Source

<p>UF3N30ZL-TM3-R</p> <p>(1)Packing Type (2)Package Type (3)Lead Free</p>	<p>(1) T: Tube, R: Tape Reel (2) TM3: TO-251, TN3: TO-252 (3) L: Lead Free, G: Halogen Free</p>
---	---

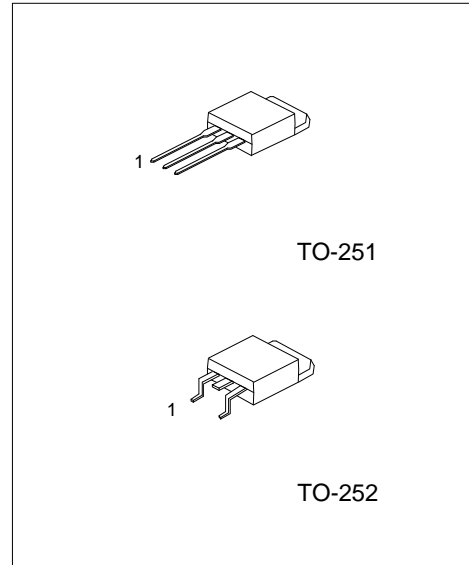

### ■ ABSOLUTE MAXIMUM RATINGS

PARAMETER		SYMBOL	RATINGS	UNIT
Drain-Source Voltage		$V_{DSS}$	300	V
Gate-Source Voltage		$V_{GSS}$	$\pm 20$	V
Continuous Drain Current	Continuous	$I_D$	3	A
	Pulsed	$I_{DM}$	12	A
Avalanche Energy		$E_{AS}$	52	mJ
Power Dissipation		$P_D$	50	W
Junction Temperature		$T_J$	+150	$^{\circ}C$
Storage Temperature Range		$T_{STG}$	-55~+150	$^{\circ}C$

Note: Absolute maximum ratings are those values beyond which the device could be permanently damaged. Absolute maximum ratings are stress ratings only and functional device operation is not implied.

### ■ ELECTRICAL CHARACTERISTICS

PARAMETER		SYMBOL	TEST CONDITIONS	MIN	TYP	MAX	UNIT	
<b>OFF CHARACTERISTICS</b>								
Drain-Source Breakdown Voltage		$BV_{DSS}$	$I_D=250\mu A, V_{GS}=0V$	300			V	
Drain-Source Leakage Current		$I_{DSS}$	$V_{DS}=300V$			1	$\mu A$	
Gate-Source Leakage Current	Forward	$I_{GSS}$	$V_{GS}=+20V, V_{DS}=0V$			10	$\mu A$	
	Reverse		$V_{GS}=-20V, V_{DS}=0V$			-10	$\mu A$	
<b>ON CHARACTERISTICS</b>								
Gate Threshold Voltage		$V_{GS(TH)}$	$I_D=250\mu A$	2		4	V	
Static Drain-Source On-State Resistance		$R_{DS(ON)}$	$V_{GS}=10V, I_D=3A$			2	$\Omega$	
<b>DYNAMIC PARAMETERS</b>								
Input Capacitance		$C_{ISS}$	$V_{GS}=0V, V_{DS}=25V, f=1MHz$		200		pF	
Output Capacitance		$C_{OSS}$				90		pF
Reverse Transfer Capacitance		$C_{RSS}$				30		pF
<b>SWITCHING PARAMETERS</b>								
Total Gate Charge		$Q_G$	$V_{DD}=50V, I_D=1.3A, I_G=100\mu A, V_{GS}=10V$		4		nC	
Gate to Source Charge		$Q_{GS}$				0.64		nC
Gate to Drain Charge		$Q_{GD}$				1.6		nC
Turn-ON Delay Time		$t_{D(ON)}$	$V_{DD}=30V, I_D=0.5A, R_G=25\Omega, V_{GS}=0\sim 10V$		10		ns	
Rise Time		$t_R$				50		ns
Turn-OFF Delay Time		$t_{D(OFF)}$				30		ns
Fall-Time		$t_F$				40		ns
<b>SOURCE- DRAIN DIODE RATINGS AND CHARACTERISTICS</b>								
Maximum Body-Diode Continuous Current		$I_S$				3	A	
Maximum Body-Diode Pulsed Current		$I_{SM}$				12	A	
Drain-Source Diode Forward Voltage		$V_{SD}$	$I_S=0.85A$			1.3	V	

## ■ TYPICAL CHARACTERISTICS

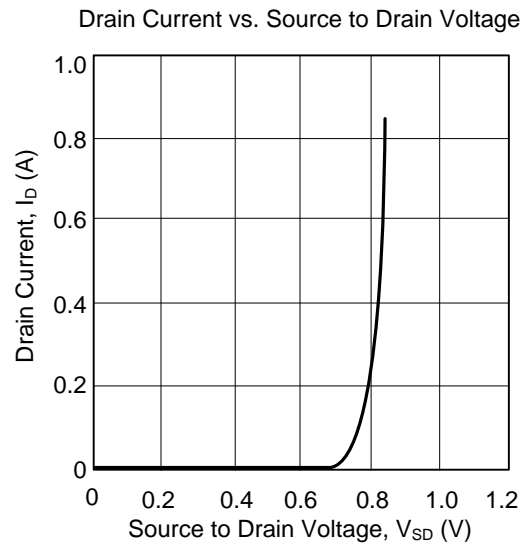
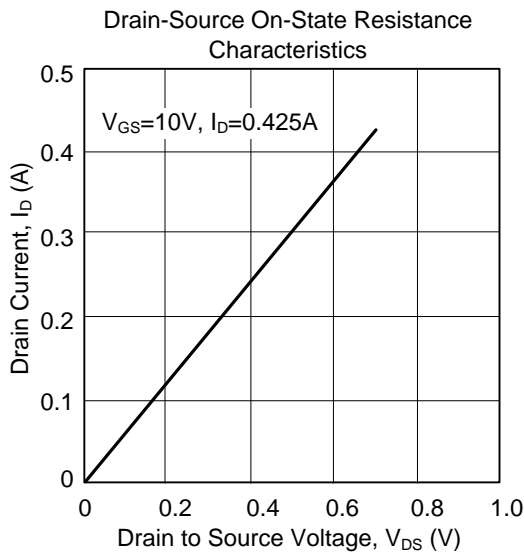
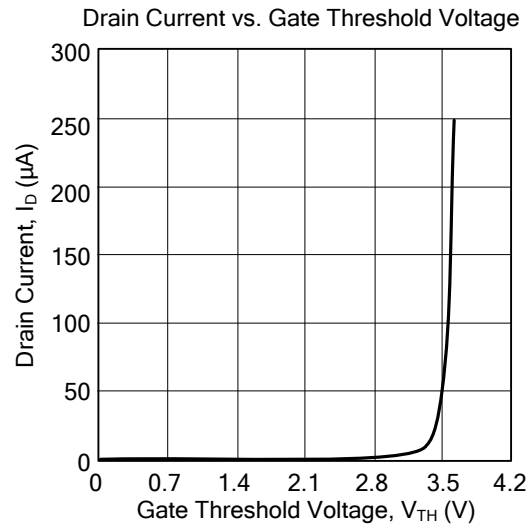
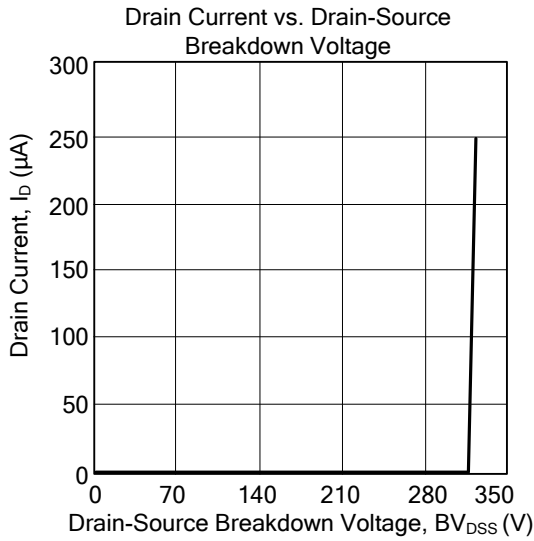

UTC assumes no responsibility for equipment failures that result from using products at values that exceed, even momentarily, rated values (such as maximum ratings, operating condition ranges, or other parameters) listed in products specifications of any and all UTC products described or contained herein. UTC products are not designed for use in life support appliances, devices or systems where malfunction of these products can be reasonably expected to result in personal injury. Reproduction in whole or in part is prohibited without the prior written consent of the copyright owner. The information presented in this document does not form part of any quotation or contract, is believed to be accurate and reliable and may be changed without notice.