



DUAL OPERATIONAL AMPLIFIERS

AZ4558

General Description

The AZ4558 consists of two high performance operational amplifiers. The IC features high gain, high input resistance, excellent channel separation, wide range of operating voltage and internal frequency compensation. It is specifically suitable for applications in differential-in, differential-out as well as in potential-metric amplifiers and where gain and phase matched channels are mandatory. The AZ4558 contains $\pm 18V$ maximum power supply voltage.

The AZ4558 is available in DIP-8 or SOIC-8 package.

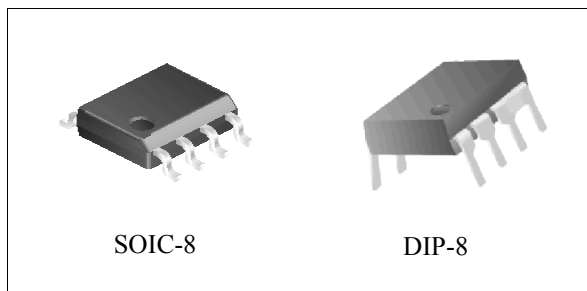

Figure 1. Package Types of AZ4558

Features

- Internal frequency compensation
- Large DC voltage gain with 100 dB typical
- High input resistance with $5M\Omega$ typical
- Low input noise voltage with $10nV/\sqrt{Hz}$
- Maximum power supply voltages: $\pm 18V$
- Compatible with NJM 4558

Applications

- Audio AC-3 decoded system
- Audio amplifier

Pin Configuration

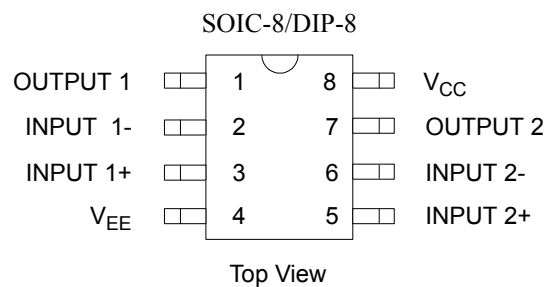

Figure 2. Pin Configuration of AZ4558

Functional Block Diagram

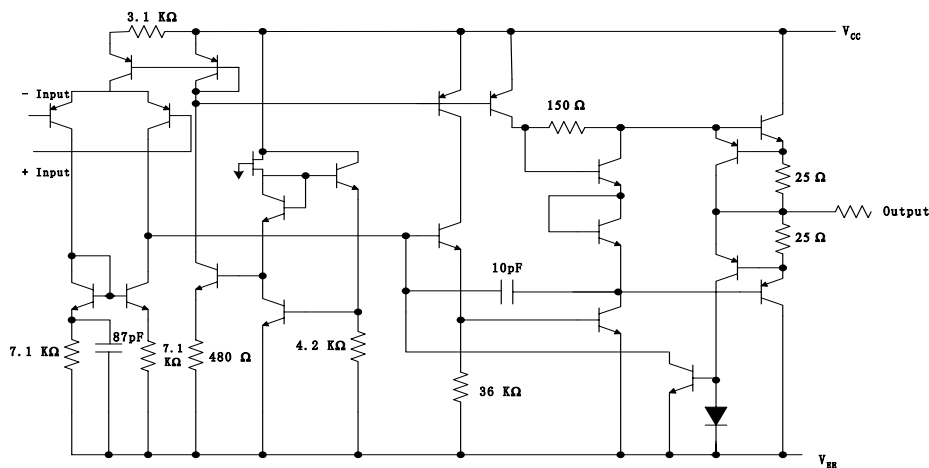

Figure 3. Representative Schematic Diagram of AZ4558 (Each amplifier)

**DUAL OPERATIONAL AMPLIFIERS****AZ4558****Ordering Information**

Package	Temperature Range	Part Number	Marking ID	Packing Type
SOIC-8	-40 to 85°C	AZ4558M	4558M	Tube, Reel
DIP-8		AZ4558P	AZ4558P	Tube

Absolute Maximum Ratings

Parameter	Symbol	Value		Unit
Power Supply Voltage	V_{CC}	+ 18		V
	V_{EE}	- 18		
Differential Input Voltage	V_{ID}	± 30		V
Input Voltage	V_{IC}	± 15		V
Power Dissipation	P_D	DIP	500	mW
		SOIC	800	
Operating Temperature Range	T_{OP}	-40 to 85		°C
Storage Temperature Range	T_{STG}	-40 to 125		°C

Note: Stresses greater than those listed under "Absolute Maximum Ratings" may cause permanent damage to the device. These are stress ratings only, and functional operation of the device at these or any other conditions beyond those indicated under "Recommended Operation Ratings" is not implied. Exposure to "Absolute Maximum Ratings" for extended periods may affect device reliability.

Recommended Operation Ratings

Parameter	Min.	Max.	Unit
Supply Voltage	± 4	± 18	V



DUAL OPERATIONAL AMPLIFIERS

AZ4558

Electrical Characteristics

Operating Conditions: $V_{CC} = +15V$, $V_{EE} = -15V$, $T_A = 25^\circ C$ unless otherwise specified.

Parameter	Conditions	Min.	Typ.	Max.	Unit
Input Offset Voltage		-	0.5	6	mV
Input Bias Current	$V_{CM} = 0V$	-	25	250	nA
Input Offset Current	$V_{CM} = 0V$	-	2.5	100	nA
Input Resistance		0.3	5	-	MΩ
Supply Current	$R_L = \infty$, Over full temperature range	-	3.3	5.7	mA
Large Signal Voltage Gain	$R_L \geq 2K$, $V_O = 1V$ to $11V$	85	100	-	dB
Common Mode Rejection Ratio	$V_{CM} = 0V$ to $V_{CC} - 15V$	80	92	-	dB
Power Supply Rejection Ratio	$V_{CC} = 5V$ to $18V$ $V_{EE} = -5V$ to $-18V$	80	95	-	dB
Output Current	Source $V_+ = 1V$, $V_- = 0V$	-	50	-	mA
	Sink $V_+ = 0V$, $V_- = 1V$	-	50	-	mA
Output Voltage Swing	$R_L \geq 2K\Omega$	± 10	± 13	-	V
	$R_L \geq 10K\Omega$	± 12	± 14	-	
Slew Rate		-	1.3	-	V / μS
Equivalent Input Noise Voltage	$R_s = 50\Omega$, $f = 1KHz$	-	10	-	nV/(HZ) ^{0.5}
Gain Bandwidth Product		-	3.4	-	MHz



Typical Characteristics

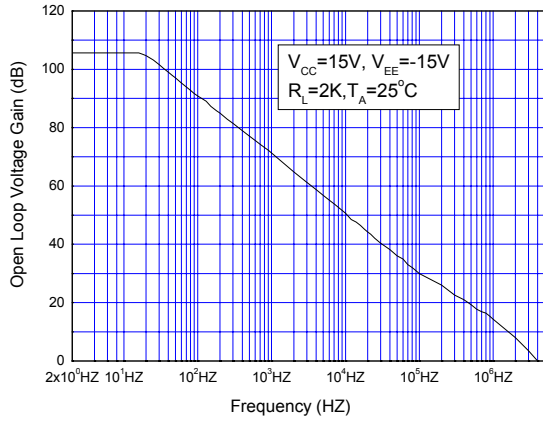

Figure 4. Open Loop Voltage Gain vs. Frequency

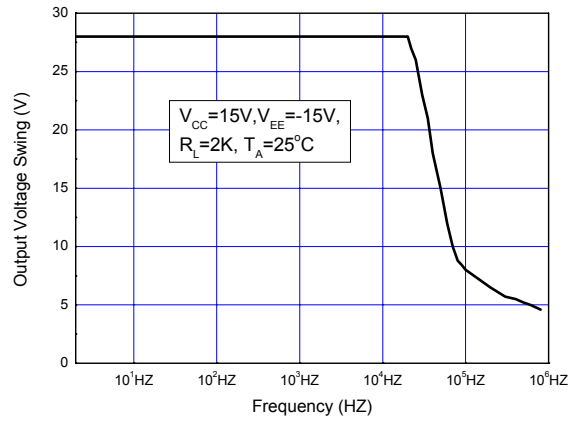

Figure 5. Maximum Output Voltage Swing vs. Frequency

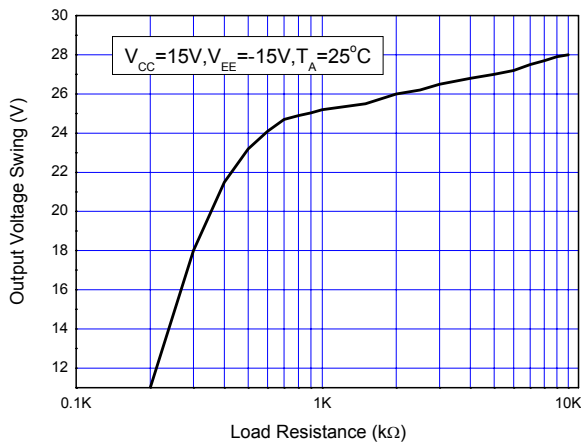

Figure 6. Maximum Output Voltage Swing vs. Load Resistance

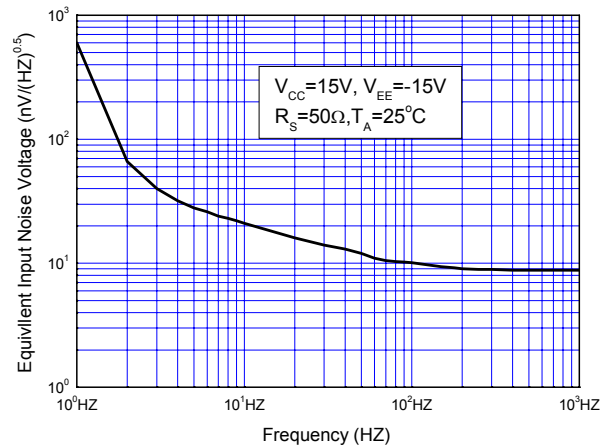

Figure 7. Equivalent Input Noise Voltage vs. Frequency



Typical Characteristics (Continued)

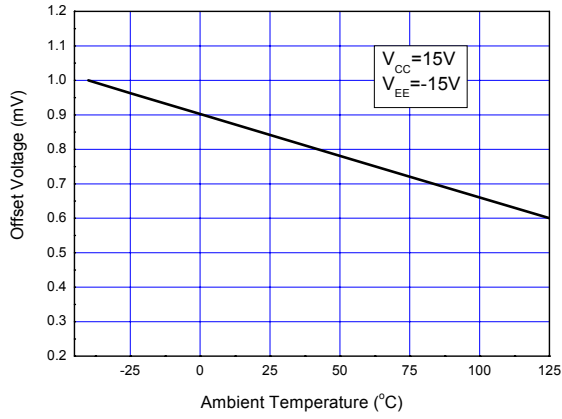

Figure 8. Input Offset Voltage vs. Temperature

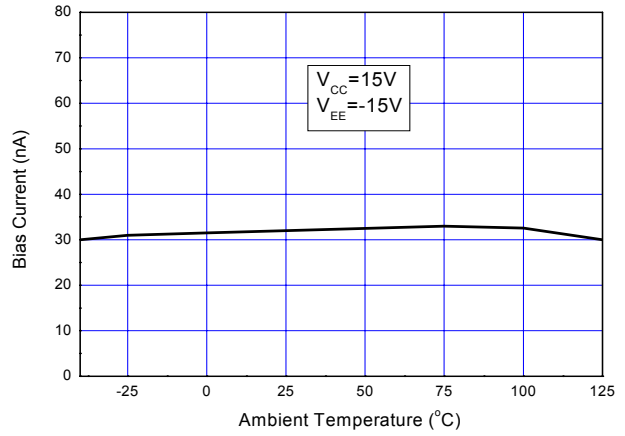

Figure 9. Input Bias Current vs. Temperature

Typical Application

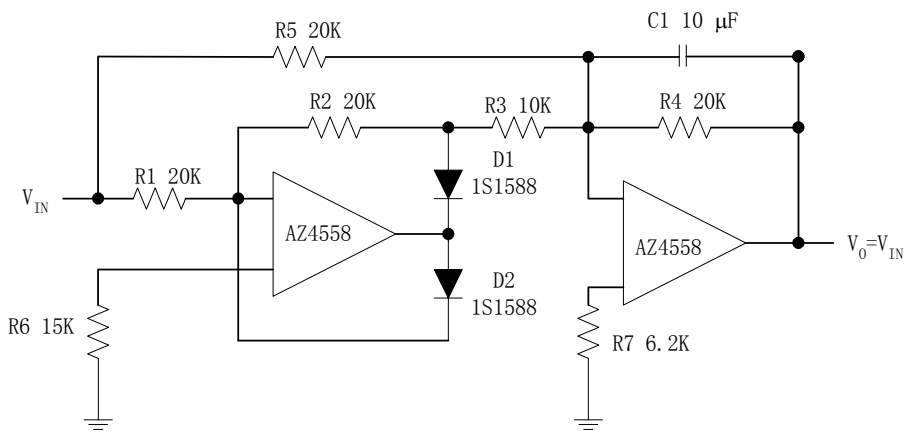

Figure 10. Typical Application of AZ4558



DUAL OPERATIONAL AMPLIFIERS

AZ4558

Mechanical Dimensions

DIP - 8

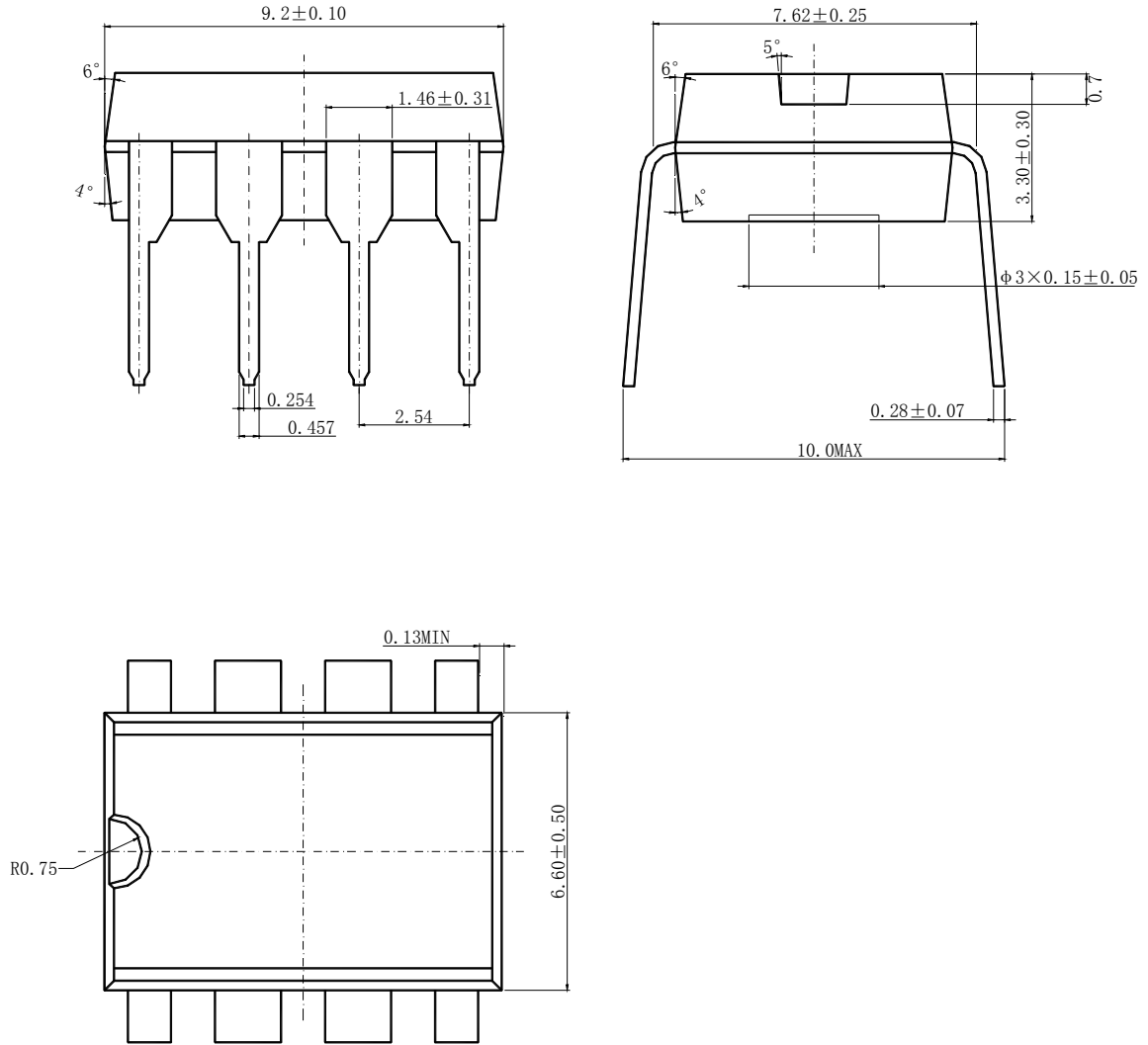



Mechanical Dimensions (Continued)

SOIC - 8

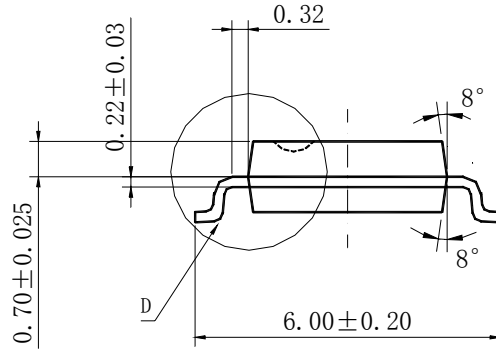
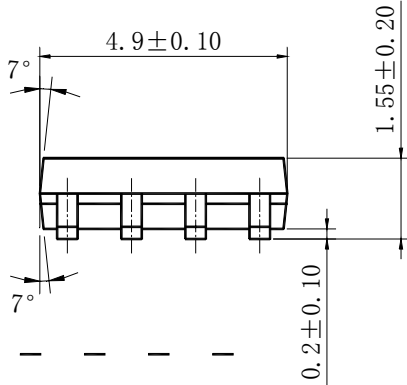

D
20:1

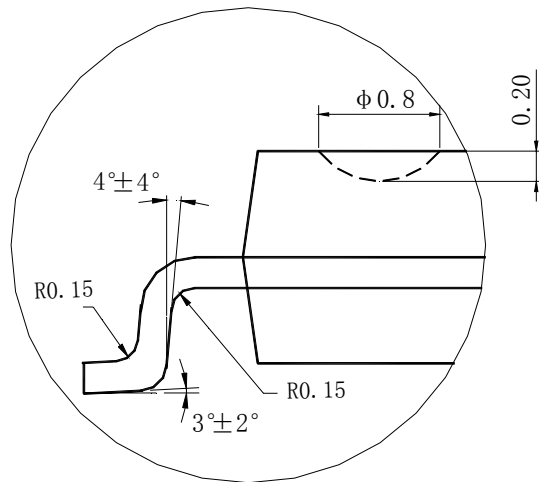
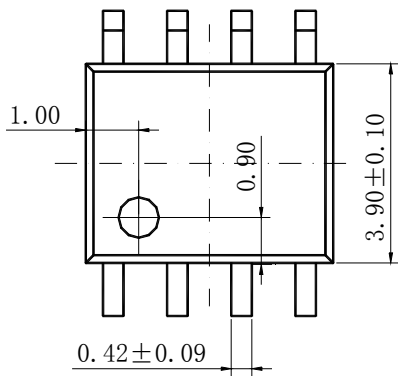



<http://www.aacmicro.com>

USA: 1510 Montague Expressway, San Jose, CA 95131, USA

Tel: 408-433-9888, Fax: 408-432-9888

China: 8th Floor, Zone B, 900 Yi Shan Road, Shanghai 200233, China

Tel: 86-21-6495-9539, Fax: 86-21-6485-9673

Taiwan: 8F, No.50, Lane10, Kee Hu Road, Nei Hu, TaiPei 114, Taiwan

Tel: 886-2-2657-8811, Fax: 886-2-2657-9090

IMPORTANT NOTICE

Advanced Analog Circuits Corporation reserves the right to make changes to its products or specifications at any time, without notice, to improve design or performance and to supply the best possible product. Advanced Analog Circuits does not assume any responsibility for use of any circuitry described other than the circuitry embodied in Advanced Analog Circuits' products. The company makes no representation that circuitry described herein is free from patent infringement or other rights of Advanced Analog Circuits Corporation.