

RoHS compliant



LC22G-103
LC22G-105

Weight : approx. 60 g
(Gear ratio 1/10)



LC22G-107
LC22G-108

Weight : approx. 110 g
(Gear ratio 1/10)

PART NUMBER DESIGNATION

LC22G - 103 1/10

Series name

LC22G-103 : DC 24 V
LC22G-105 : DC 12 V
LC22G-107 : DC 24 V
LC22G-108 : DC 12 V

Gear ratio

1/10 1/150
1/25 1/300
1/30 1/500
1/50 1/1000
1/100 1/1500

LIST OF PART NUMBERS

Gear ratio	Part number	Part number
1/10	LC22G-103 1/10	LC22G-105 1/10
1/25	LC22G-103 1/25	LC22G-105 1/25
1/50	LC22G-103 1/50	LC22G-105 1/50
1/100	LC22G-103 1/100	LC22G-105 1/100
1/150	LC22G-103 1/150	LC22G-105 1/150
1/300	LC22G-103 1/300	LC22G-105 1/300
1/500	LC22G-103 1/500	LC22G-105 1/500
1/1000	LC22G-103 1/1000	➔ LC22G-105 1/1000
1/1500	➔ LC22G-103 1/1500	➔ LC22G-105 1/1500

Gear ratio	Part number	Part number
1/10	LC22G-107 1/10	LC22G-108 1/10
1/30	LC22G-107 1/30	LC22G-108 1/30
1/50	LC22G-107 1/50	LC22G-108 1/50
1/100	LC22G-107 1/100	LC22G-108 1/100
1/150	LC22G-107 1/150	LC22G-108 1/150
1/300	LC22G-107 1/300	LC22G-108 1/300
1/500	LC22G-107 1/500	LC22G-108 1/500
1/1000	➔ LC22G-107 1/1000	➔ LC22G-108 1/1000
1/1500	➔ LC22G-107 1/1500	➔ LC22G-108 1/1500

※Verify the above part numbers when placing orders.

The products indicated by ➔ mark are manufactured upon receipt of order basis.

LC22G

DC GEARED MOTORS

STANDARD SPECIFICATIONS

<Motor only>

Part number	Rated voltage	Rated torque	Rated speed	Rated current	No load speed	No load current	Starting torque	Starting current
LC22G-103	24 V	1.96 mN·m	4900 min ⁻¹	80 mA	6100 min ⁻¹	25 mA	10.0 mN·m	350 mA
LC22G-105	12 V		5100 min ⁻¹	160 mA		50 mA	11.96 mN·m	850 mA
LC22G-107	24 V		7000 min ⁻¹	105 mA	8100 min ⁻¹	30 mA	14.42 mN·m	550 mA
LC22G-108	12 V		6100 min ⁻¹	180 mA	7300 min ⁻¹	60 mA	11.96 mN·m	600 mA

<With gearbox>

LC22G-103

Gear ratio	1/10	1/25	1/50	1/100	1/150	1/300	1/500	1/1000	1/1500
Rated torque mN·m	4.9	7.8	9.8	14.7	24.5				
Rated speed min ⁻¹	578	234	121	60	40.5	20.9	12.4	6.1	4.1
Rated current A	0.04		0.03						
No load speed min ⁻¹	610	244	122	61	41	21	12.5	6.1	4.1

LC22G-105

Gear ratio	1/10	1/25	1/50	1/100	1/150	1/300	1/500	1/1000	1/1500
Rated torque mN·m	4.9	7.8	9.8	14.7	24.5				
Rated speed min ⁻¹	600	244	122	61	40.5	20.4	12.4	6.2	4.1
Rated current A	0.06								
No load speed min ⁻¹	620	248	124	62	41	20.5	12.5	6.2	4.1

LC22G-107

Gear ratio	1/10	1/30	1/50	1/100	1/150	1/300	1/500	1/1000	1/1500
Rated torque mN·m	14.7	49.0	78.5	166.7	196.1	294.2			
Rated speed min ⁻¹	718	237	138	69	45	23.5	14	7.6	5.2
Rated current A	0.1		0.11		0.12	0.1		0.07	
No load speed min ⁻¹	800	267	160	80	53	26.5	16	8	5.3

LC22G-108

Gear ratio	1/10	1/30	1/50	1/100	1/150	1/300	1/500	1/1000	1/1500
Rated torque mN·m	14.7	49.0	78.5	166.7	196.1	294.2			
Rated speed min ⁻¹	670	215	126	64.5	42.5	22	13.5	6.8	4.7
Rated current A	0.2			0.17			0.15	0.11	0.08
No load speed min ⁻¹	720	240	144	72	48	24	14.5	7.2	4.8

PERFORMANCE CURVES

(Figures in the table are typical values under rated operating condition.)

Motor only

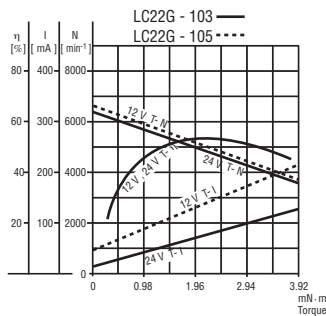

Gear ratio 1/100

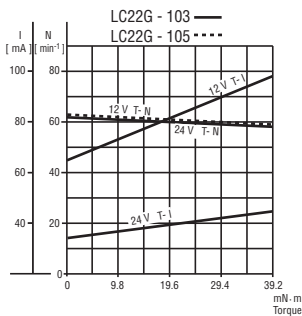

Motor only

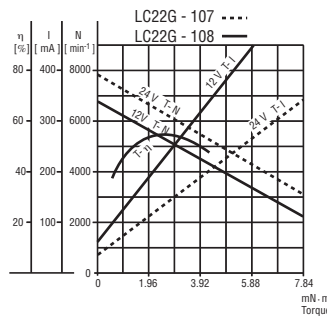

Gear ratio 1/100

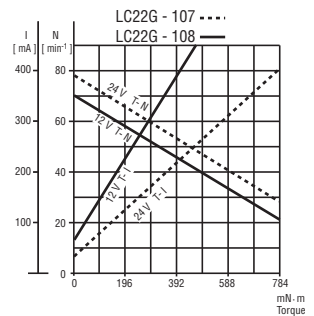

LC22G

DC GEARED MOTORS

OUTLINE DIMENSIONS

(Unit: mm)

- LC22G-103
- LC22G-105

4 - M2 × 0.4 (D = 4.4)

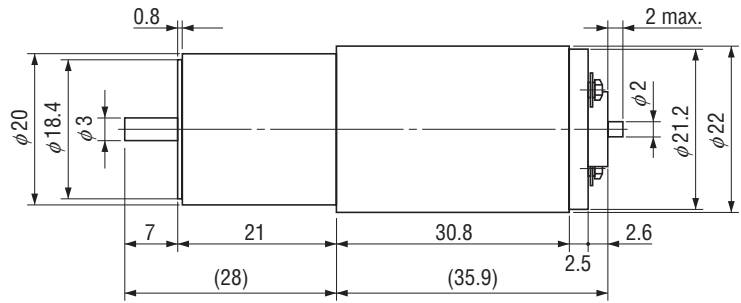
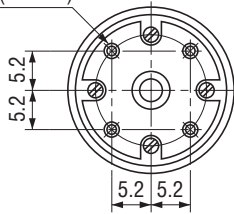

- LC22G-107
- LC22G-108

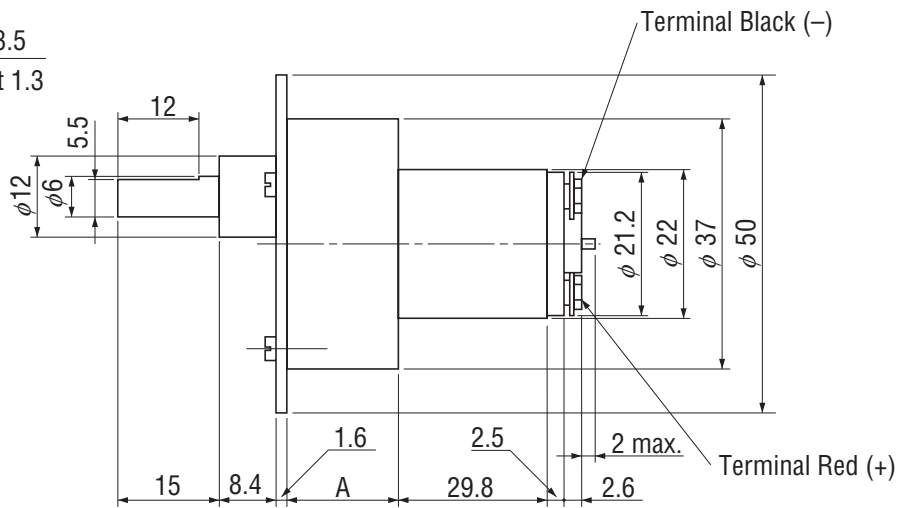
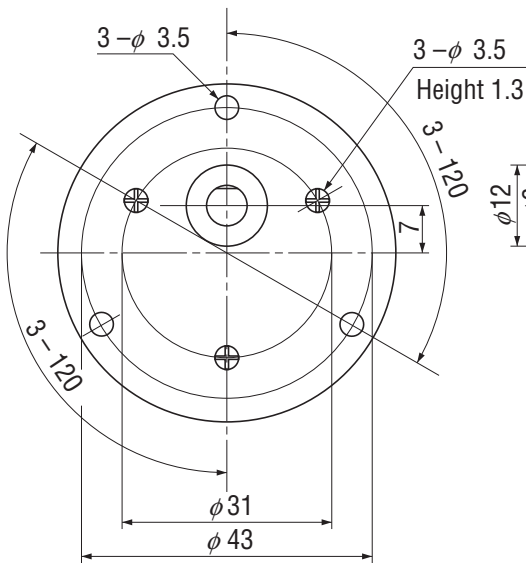

Marks A

Gear ratio	1/10	1/30	1/50	1/100	1/150	1/300	1/500	1/1000	1/1500
A	16.5	19.0	21.5	24.0	26.5	29.0			