

## High-density Signal Conditioners 10-RACK

### SIGNAL TRANSMITTER

(fast response)

#### Functions & Features

- Converting a DC input into two standard process signals
- Optional second channel output available at the front terminals and at the Standard Rack connector

#### Typical Applications

- Isolation between control room and field instrumentation

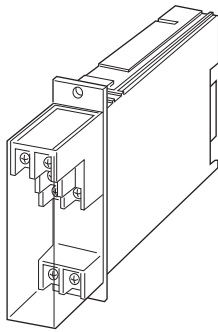

**MODEL: 10VK-[1][2][3]-R[4]**

### ORDERING INFORMATION

- Code number: 10VK-[1][2][3]-R[4]
- Specify a code from below for each [1] through [4].  
(e.g. 10VK-6A6-R/Q)
- Special input range (For codes Z & 0)
- Specify the specification for option code /Q  
(e.g. /C01)

#### [1] INPUT

##### Current

- A: 4 - 20 mA DC (Input resistance 250  $\Omega$ )
- D: 0 - 20 mA DC (Input resistance 50  $\Omega$ )
- G: 0 - 1 mA DC (Input resistance 1000  $\Omega$ )
- H: 10 - 50 mA DC (Input resistance 100  $\Omega$ )
- Z: Specify current (See INPUT SPECIFICATIONS)

##### Voltage

- 1: 0 - 10 mV DC (Input resistance 10 k $\Omega$  min.)
- 2: 0 - 100 mV DC (Input resistance 100 k $\Omega$  min.)
- 3: 0 - 1 V DC (Input resistance 1 M $\Omega$  min.)
- 4: 0 - 10 V DC (Input resistance 1 M $\Omega$  min.)
- 5: 0 - 5 V DC (Input resistance 1 M $\Omega$  min.)
- 6: 1 - 5 V DC (Input resistance 1 M $\Omega$  min.)
- 0: Specify voltage (See INPUT SPECIFICATIONS)

#### [2] OUTPUT 1

##### Current

- A: 4 - 20 mA DC (Load resistance 600  $\Omega$  max.)
- B: 2 - 10 mA DC (Load resistance 1200  $\Omega$  max.)
- C: 1 - 5 mA DC (Load resistance 2400  $\Omega$  max.)
- D: 0 - 20 mA DC (Load resistance 600  $\Omega$  max.)
- E: 0 - 16 mA DC (Load resistance 750  $\Omega$  max.)
- F: 0 - 10 mA DC (Load resistance 1200  $\Omega$  max.)
- G: 0 - 1 mA DC (Load resistance 12 k $\Omega$  max.)

##### Voltage

- 1: 0 - 10 mV DC (Load resistance 10 k $\Omega$  min.)
- 2: 0 - 100 mV DC (Load resistance 100 k $\Omega$  min.)
- 3: 0 - 1 V DC (Load resistance 100  $\Omega$  min.)
- 4: 0 - 10 V DC (Load resistance 1000  $\Omega$  min.)
- 5: 0 - 5 V DC (Load resistance 500  $\Omega$  min.)
- 6: 1 - 5 V DC (Load resistance 500  $\Omega$  min.)

#### [3] OUTPUT 2

0: None

##### Voltage

- 6: 1 - 5 V DC (Load resistance 5000  $\Omega$  min.)

### POWER INPUT

#### DC Power

R: 24 V DC

(Operational voltage range 24 V  $\pm$ 10 %, ripple 10 %p-p max.)

#### [4] OPTIONS

blank: none

/Q: With options (specify the specification)

### SPECIFICATIONS OF OPTION: Q

#### COATING (For the detail, refer to M-System's web site.)

/C01: Silicone coating

/C02: Polyurethane coating

/C03: Rubber coating

### GENERAL SPECIFICATIONS

**Construction:** Rack-mounted; terminal access via screw terminals at the front and via card-edge connector at the rear; terminal cover provided

#### Connection

**Input:** M3.5 screw terminals (torque 0.8 N·m)

**Output:** Card-edge connector and M3.5 screw terminals (torque 0.8 N·m)

**Power input:** Supplied from card-edge connector

**Screw terminal:** Nickel-plated steel

**Housing material:** Flame-resistant resin (black)

**Isolation:** Input to output 1 to output 2 to power

**Overrange output:** Approx. -10 to +120 % at 1 - 5 V

Zero adjustment: -5 to +5 % (front)

Span adjustment: 95 to 105 % (front)

## INPUT SPECIFICATIONS

■ **DC Current:** Input resistor incorporated

Specify input resistance value for code Z.

( $R \leq 2 W \div [F.S. \text{ Current}]^2$ )

■ **DC Voltage:** 0 - 300 V DC

**Minimum span:** 3 mV

**Offset:** Max. 1.5 times span

**Input Resistance**

Span 3 - 10 mV :  $\geq 10 \text{ k}\Omega$

Span 10 - 100 mV :  $\geq 10 \text{ k}\Omega$

Span 0.1 - 1 V :  $\geq 100 \text{ k}\Omega$

Span  $\geq 1 \text{ V}$  :  $\geq 1 \text{ M}\Omega$

## OUTPUT SPECIFICATIONS

With the input voltage code 3, 4, 5, 6 and current, the output goes below 0 % when the input is open.

## INSTALLATION

**Current consumption:** Approx. 25 mA with voltage output 1

Approx. 45 mA with current output 1

**Operating temperature:** -5 to +55°C (23 to 131°F)

**Operating humidity:** 30 to 90 %RH (non-condensing)

**Mounting:** Standard Rack 10BXx

**Weight:** 200 g (0.44 lb)

## PERFORMANCE in percentage of span

**Accuracy:**  $\pm 0.05 \%$

**Temp. coefficient:**  $\pm 0.015 \%/^{\circ}\text{C}$  ( $\pm 0.008 \%/^{\circ}\text{F}$ )

**Response time:** Approx. 25 msec. (0 - 90 %)

**Line voltage effect:**  $\pm 0.1 \%$  over voltage range

**Insulation resistance:**  $\geq 100 \text{ M}\Omega$  with 500 V DC

**Dielectric strength:** 500 V AC @ 1 minute

(input to output 1 to output 2 to power)

1500 V AC @ 1 minute (input or output or power to ground)

**EXTERNAL DIMENSIONS & TERMINAL ASSIGNMENTS unit: mm (inch)**

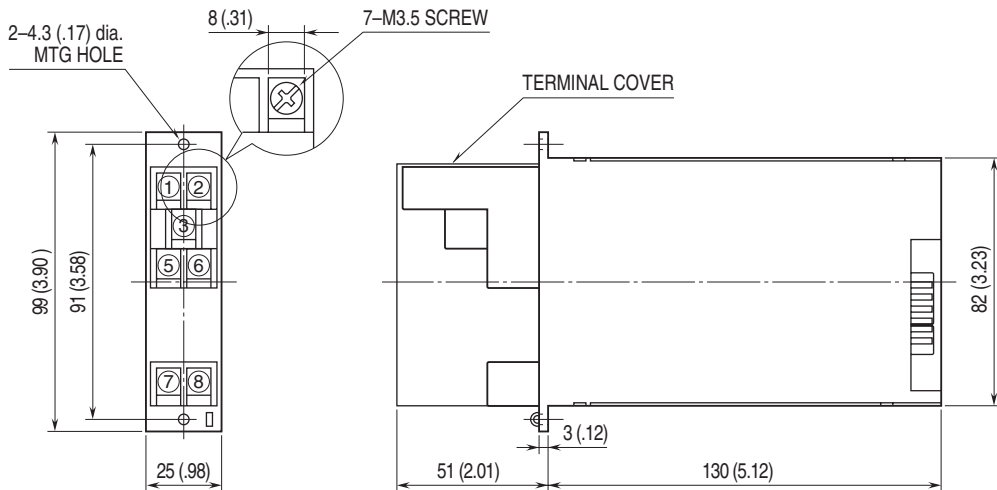

**SCHEMATIC CIRCUITRY & CONNECTION DIAGRAM**

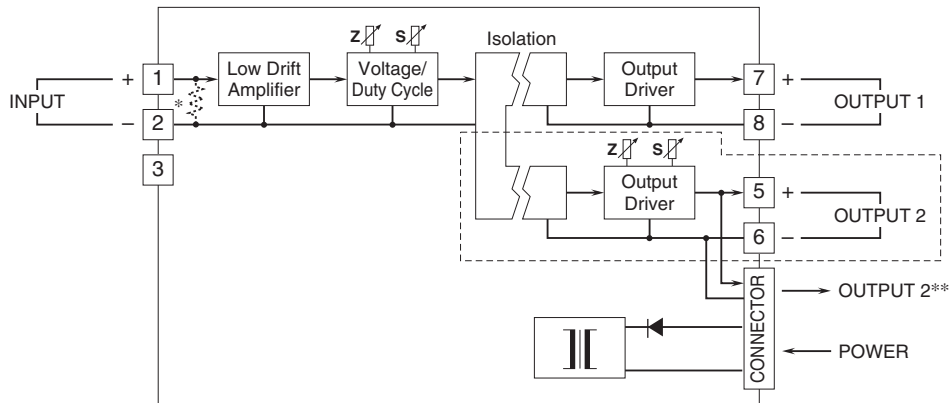

\* Input shunt resistor incorporated for current input  
 \*\*1 output type has the output 1 connected to the card-edge connector in parallel.  
 Remark 1) The section enclosed by broken line is only for 2nd output channel.



Specifications are subject to change without notice.