

2

1

DATE	REV	ECN	APP'D. BY
03-10-04	A1	6351	JMB
1-19-06	A2	7441	JM
2-10-11	A3	9125	SMN
5-23-12	A4	9476	SMN
1-7-15	A5	10173	TRM

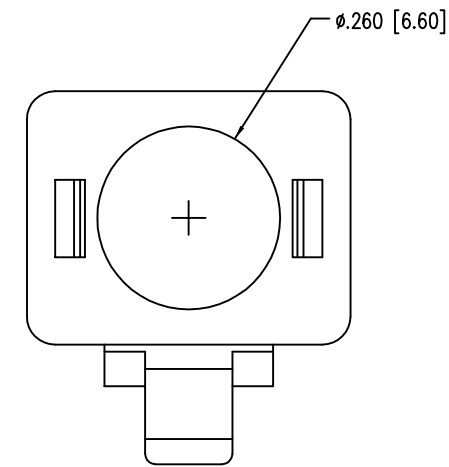
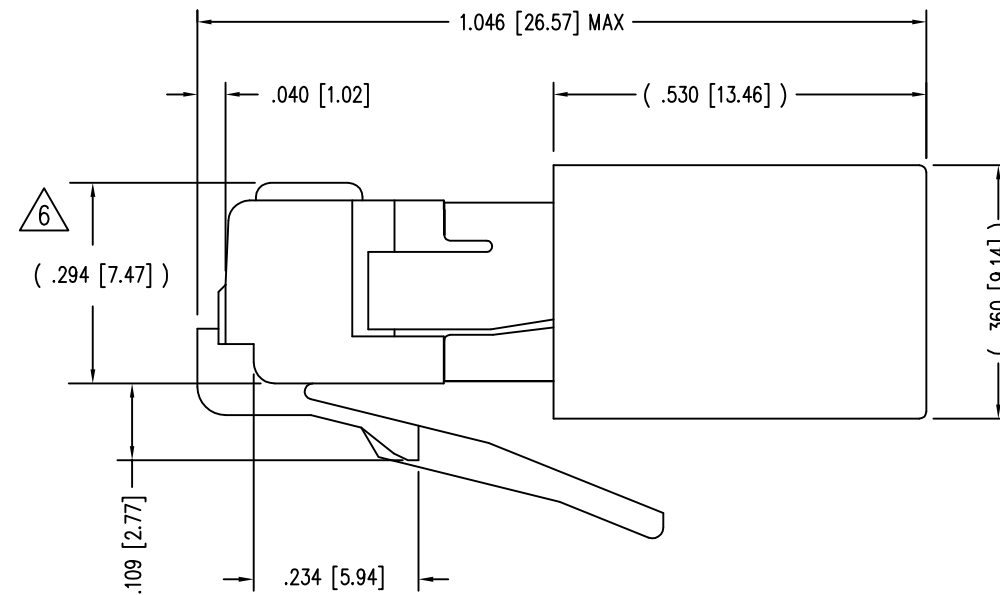
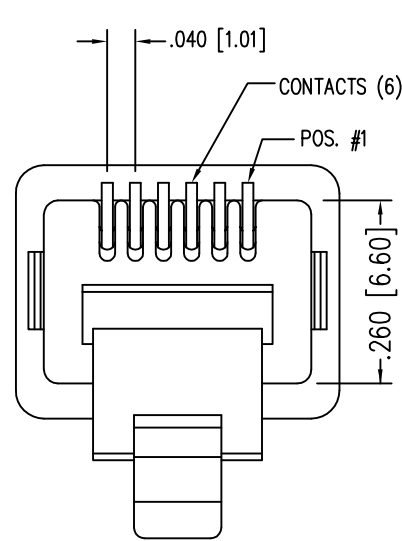
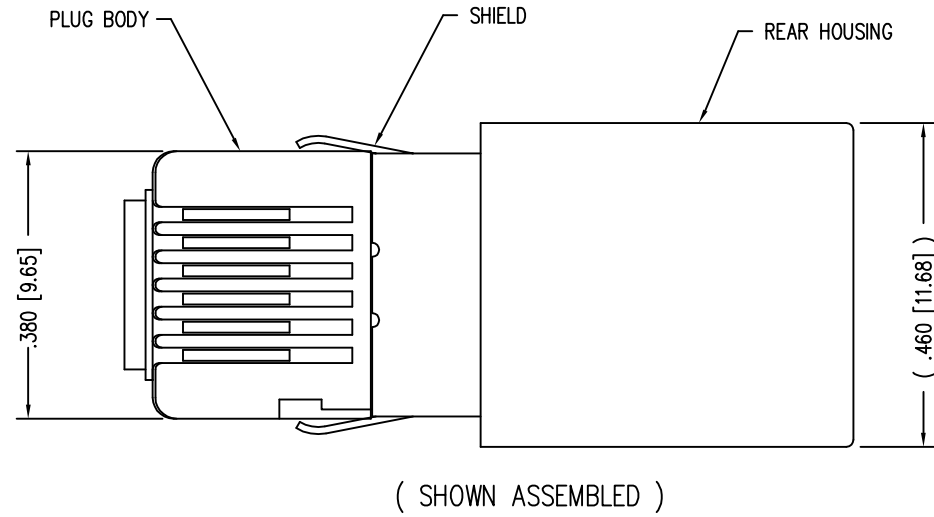

NOTES:

- 1- PLUG KIT CONSISTS OF :
PRE-INSERTED PLUG HOUSING & SHIELD
LOAD BAR
FERRULE
- 2- MATERIALS :
FRONT HOUSING PLASTIC : CLEAR POLYCARBONATE, UL 94-V0
LOAD BAR : CLEAR POLYCARBONATE, UL 94-V0
SHIELD : TIN PLATED BRASS
CONTACTS : PHOSPHOR BRONZE, SELECTIVE GOLD PLATING
FERRULE : NICKEL OR TIN PLATED BRASS
- 3- CONTACTS TERMINATE STRANDED CONDUCTORS UP TO .037 [0.94] OUTSIDE DIAMETER OF INSULATION.
- 4- FOR PLUG SPECIFICATION SEE PRO26-01.
- 5- DIMENSIONS & TOLERANCES COMPLY WITH TIA-1096 STANDARD
- △ TERMINATED PLUG HEIGHT: .237 [6.02] ±.005 [0.13] ON CABLE

BULK	50 MICRO-INCHES [1.27um]	940-SP-360606-A151
PACKAGE	CONTACT PLATING IN MATING AREA	PART NUMBER

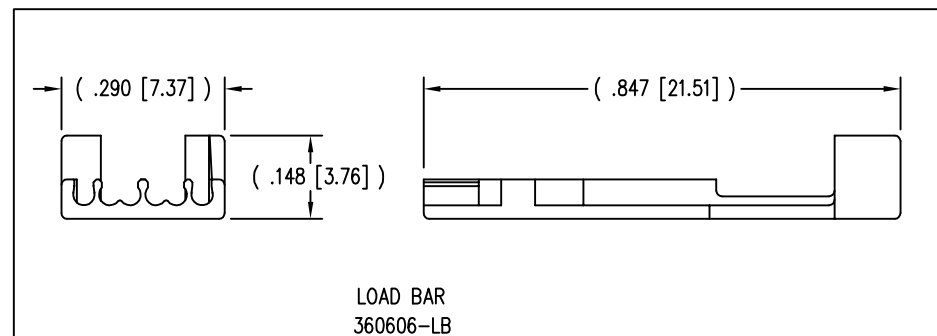
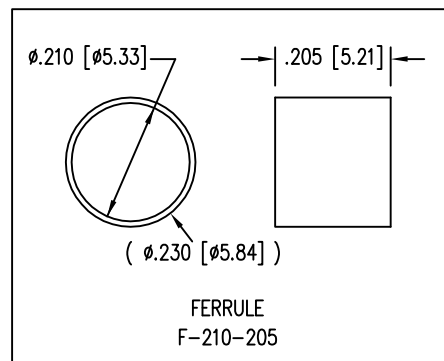

THIRD ANGLE PROJECTION

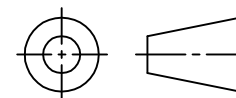

1118 Susquehanna Trail South
Glen Rock, PA 17327-9199
(717) 235-7512
<http://www.stewartconnector.com>

DO NOT SCALE DRAWING
DRAWING IS SUBJECT TO CHANGE WITHOUT NOTICE

TITLE: 6 X 6 SHIELED PLUG

DIMENSIONS: INCHES [METRIC]
UNLESS OTHERWISE SPECIFIED TOLERANCES ARE ±.005 [0.13] ANGLES ARE ± 1°

THIS DRAWING AND THE SUBJECT MATTER SHOWN THEREON ARE CONFIDENTIAL AND THE PROPRIETARY PROPERTY OF STEWART CONNECTOR AND SHALL NOT BE REPRODUCED, COPIED, OR USED IN ANY MANNER WITHOUT PRIOR WRITTEN CONSENT OF STEWART CONNECTOR. THIS PRODUCT MAY BE PROTECTED BY ONE OR MORE OF THE FOLLOWING US PATENTS:
5628647 6402559 6409535 6524128
7753717 8033863
OTHER PATENTS MAY BE PENDING.

DRN BY:	DB	DATE	3-15-00
APPD BY:	JF	DATE	3-15-00
DWG NO.	CT360143	REV.	A5

SHEET NO. 1 OF 1



2

1

AutoCAD

REV. 1-19-11

B

B

A

A