

AZ762H

16 A SPDT MINIATURE HIGH TEMPERATURE POWER RELAY

FEATURES

- High ambient operating temperature (105°C)
- Dielectric strength 5000 Vrms
- Low cost
- Epoxy sealed versions available
- 16 Amp switching (standard coil only)
- Class B (130°C) standard
- Isolation spacing greater than 10 mm
- UL, CUR file E44211, VDE40006031



CONTACTS

Arrangement	SPDT (1 Form C) SPST (1 Form A)
Ratings	Resistive load: Max. switched power: 480 W or 4432 VA Max. switched current: 16 A Max. switched voltage: 150* VDC or 440 VAC *Note: If switching voltage is greater than 30VDC, special precautions must be taken. Please contact the factory.
Rated Load UL, CUR	16 A at 277 VAC general use, 100k cycles 105°C (10A sensitive coil)
VDE	16 A at 250 VAC resistive, 105°C (10A sensitive coil) 6 A at 400 VAC resistive, 105°C
Material	Silver nickel. Gold plating available
Resistance	< 50 milliohms initially (using 6 V 1 A method)

COIL

Power	
At Pickup Voltage (typical)	196 mW Standard 141 mW Sensitive
Max. Continuous Dissipation	1.7 W at 20°C (68°F) ambient
Temperature Rise	26°C (47°F) at nominal coil voltage
Max. Temperature	130°C (266°F)

GENERAL DATA

Life Expectancy Mechanical Electrical	Minimum operations 1 x 10 ⁷ 1 x 10 ⁵ at 16 A 277 VAC general use
OperateTime (typical)	7 ms at nominal coil voltage
ReleaseTime (typical)	3 ms at nominal coil voltage (with no coil suppression)
Dielectric Strength (at sea level for 1 min.)	5000 Vrms coil to contact 1000 Vrms between open contacts
Insulation Resistance	1000 megohms min. at 20°C 500 VDC 50% RH
Dropout	Greater than 10% of nominal coil voltage
Ambient Temperature Operating Storage	At nominal coil voltage -40°C (-40°F) to 105°C (221°F) -40°C (-40°F) to 130°C (266°F)
Vibration	0.062" DA at 10–55 Hz
Shock	10 g
Enclosure	P.B.T. polyester
Terminals	Tinned copper alloy, P.C.
Max. Solder Temp.	270°C (518°F)
Max. Solder Time	5 seconds
Max. Solvent Temp.	80°C (176°F)
Max. Immersion Time	30 seconds
Weight	14 grams

NOTES

1. All values at 20°C (68°F).
2. Relay may pull in with less than "Must Operate" value.
3. Specifications subject to change without notice.



AMERICAN ZETTLER, INC.

www.azettler.com

75 COLUMBIA • ALISO VIEJO, CA 92656 • PHONE: (949) 831-5000 • FAX: (949) 831-8642 • E-MAIL: SALES@AZETTLER.COM

11/13/08W

AZ762H

RELAY ORDERING DATA

COIL SPECIFICATIONS - STANDARD RELAYS				ORDER NUMBER*	
Nominal Coil VDC	Must Operate VDC	Max. Continuous VDC	Coil Resistance $\pm 10\%$	Unsealed	Sealed
5	3.5	10.2	62	AZ762H-1CB-5D	AZ762H-1CB-5DE
6	4.2	12.3	90	AZ762H-1CB-6D	AZ762H-1CB-6DE
9	6.3	18.5	202	AZ762H-1CB-5D	AZ762H-1CB-19DE
12	8.4	24.7	360	AZ762H-1CB-12D	AZ762H-1CB-12DE
18	12.6	37.0	810	AZ762H-1CB-18D	AZ762H-1CB-18DE
24	16.8	49.4	1440	AZ762H-1CB-24D	AZ762H-1CB-24DE
48	33.6	98.0	5760	AZ762H-1CB-48D	AZ762H-1CB-48DE
60	42.0	112.9	7500	AZ762H-1CB-60D	AZ762H-1CB-60DE

COIL SPECIFICATIONS - SENSITIVE RELAYS				ORDER NUMBER*	
Nominal Coil VDC	Must Operate VDC	Max. Continuous VDC	Coil Resistance $\pm 10\%$	Unsealed	Sealed
5	3.75	10.2	100	AZ762H-1CB-5DS	AZ762H-1CB-5DSE
6	4.50	12.3	144	AZ762H-1CB-6DS	AZ762H-1CB-6DSE
9	6.75	18.5	324	AZ762H-1CB-9DS	AZ762H-1CB-9DSE
12	9.0	24.7	576	AZ762H-1CB-12DS	AZ762H-1CB-12DSE
18	13.5	37.0	1296	AZ762H-1CB-18DS	AZ762H-1CB-18DSE
24	18.0	49.4	2304	AZ762H-1CB-24DS	AZ762H-1CB-24DSE
48	36.0	98.0	9216	AZ762H-1CB-48DS	AZ762H-1CB-48DSE
60	45.0	112.9	12857	AZ762H-1CB-60DS	AZ762H-1CB-60DSE

* For 1 form A contacts substitute "-1AB" for "-1CB." For gold plated contacts add suffix "A."



AMERICAN ZETTLER, INC.

www.azettler.com

75 COLUMBIA • ALISO VIEJO, CA 92656 • PHONE: (949) 831-5000 • FAX: (949) 831-8642 • E-MAIL: SALES@AZETTLER.COM

11/13/08W

AZ762H

HARDWARE ORDERING DATA

DESCRIPTION	ORDER NUMBER	DESCRIPTION	ORDER NUMBER
Socket	ST484-U1	Retainer	ST482-3

MECHANICAL DATA

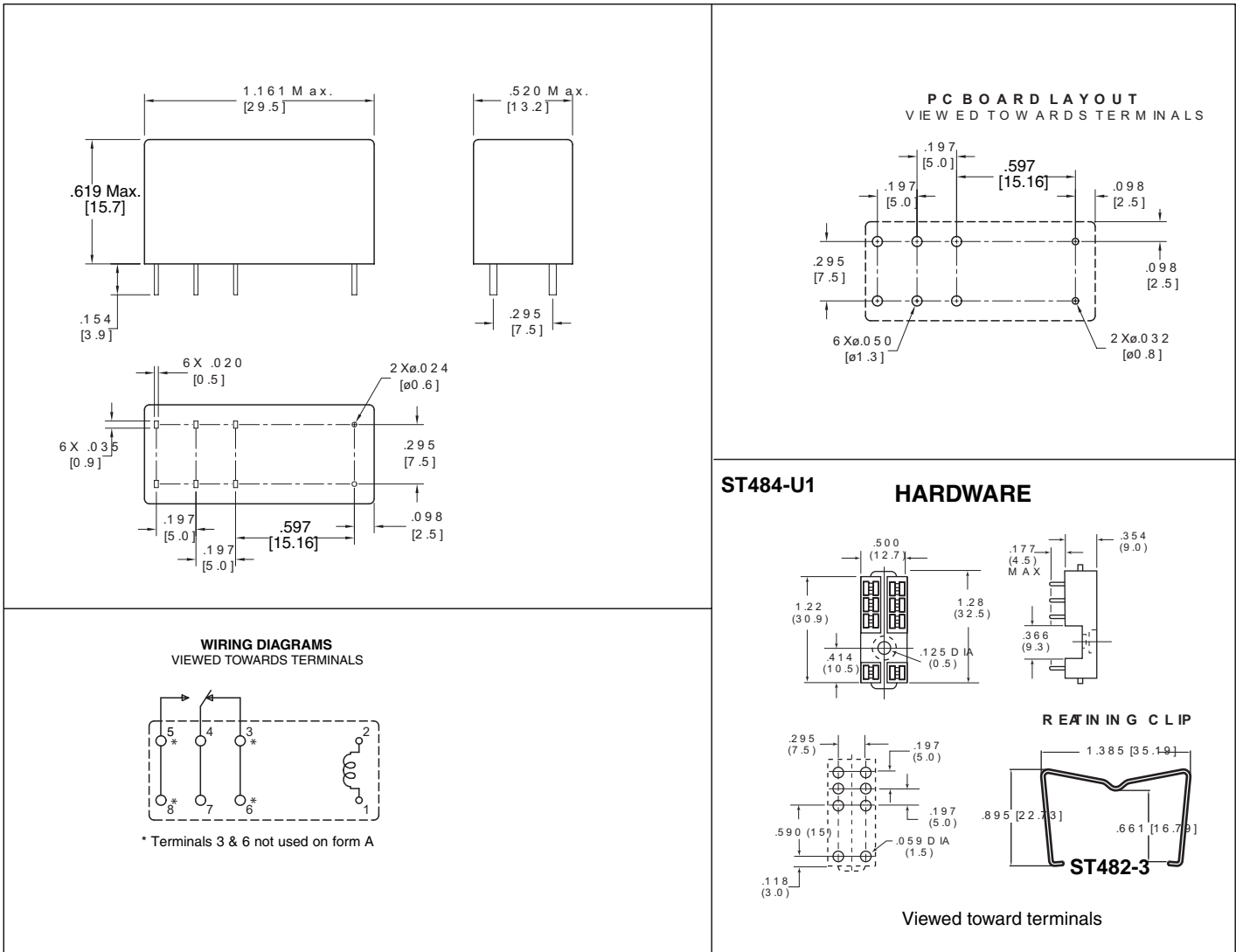

Dimensions in inches with metric equivalents in parentheses. Tolerance: $\pm .010$ "



AMERICAN ZETTLER, INC.

www.azettler.com

75 COLUMBIA • ALISO VIEJO, CA 92656 • PHONE: (949) 831-5000 • FAX: (949) 831-8642 • E-MAIL: SALES@AZETTLER.COM

11/13/08W