

PSR SERIES PSR-78xxLF WIDE INPUT NON-ISOLATED REGULATED SINGLE OUTPUT SIP3

Wide Input Range
Efficiency up to 96%
Available Outputs:
+/- 3.3, 5, 6.5, 9, 12, 15 VDC
 Other specifications please enquire.

Electrical Specifications

(Typical at + 25° C, nominal input voltage, rated output current unless otherwise specified)

Output Specifications

Voltage accuracy (at 100% load)	+/- 2 %, typ. / +/- 3%, max.
Line voltage regulation (Vin=min. to max. at full load)	+/- 0,2%, typ. / +/- 0.4%, max.
Load voltage regulation (10% - 100%)	+/- 0.4%, typ. / 0.6%, max.
Ripple and noise (at 20 MHz BW)	20 mV p-p, typ. / 35 mV p-p, max.
Short circuit input power	0.5W, typ. / 1.8W, max.
Short circuit protection	Continuous, automatic recovery
Switching frequency	280KHz, min. / 330 KHz, typ. / 450 KHz, max.
Quiescent current	Positive Output: 5mA, typ / 8mA, max. Negative Output: 7mA, typ. / 13mA, max.
Thermal shutdown (Internal IC junction)	150 °C, typ.
Temperature coefficient (-40°C – +85°C ambient)	0.02% °C, max.
Capacitance load	1000uF, max.

Common Specifications

Operating temperature (ambient)	- 40° C to + 85° C / 100°C case max.
Storage temperature	- 55 °C to + 125 °C
Cooling	Free air convection
MTBF (MIL-HDBK-217F)	2000 KHrs, min.

Physical Characteristics

Case material	Plastic (UL94-V0)
“RoHS compliant”	Soldering 260 °C / max. 10 sec.

Examples for Partnumbers

PART NO.	INPUT VOLTAGE (VDC)	OUTPUT VOLTAGE (VDC)	OUTPUT CURRENT (max. mA)	EFFICIENCY	
				Min Vin (%)	Max Vin (%)
PSR-783R3LF	4.75-28	3.3	500	90	80
	4.75-25	-3.3	-400	73	78
PSR-7805LF	6.5-32	5.0	500	93	84
	6.0-27	-5.0	-400	78	83
PSR-786.5LF	8-32	6.5	500	94	87
	6.0-25	-6.5	-300	83	85
PSR-7809LF	11-32	9.0	500	95	91
	7.0-23	-9.0	-200	87	86
PSR-7812LF	15-32	12	500	95	92
	7.0-20	-12	-200	85	87
PSR-7815LF	18-32	15	500	96	93
	7.0-17	-15	-200	84	89

Dimensions

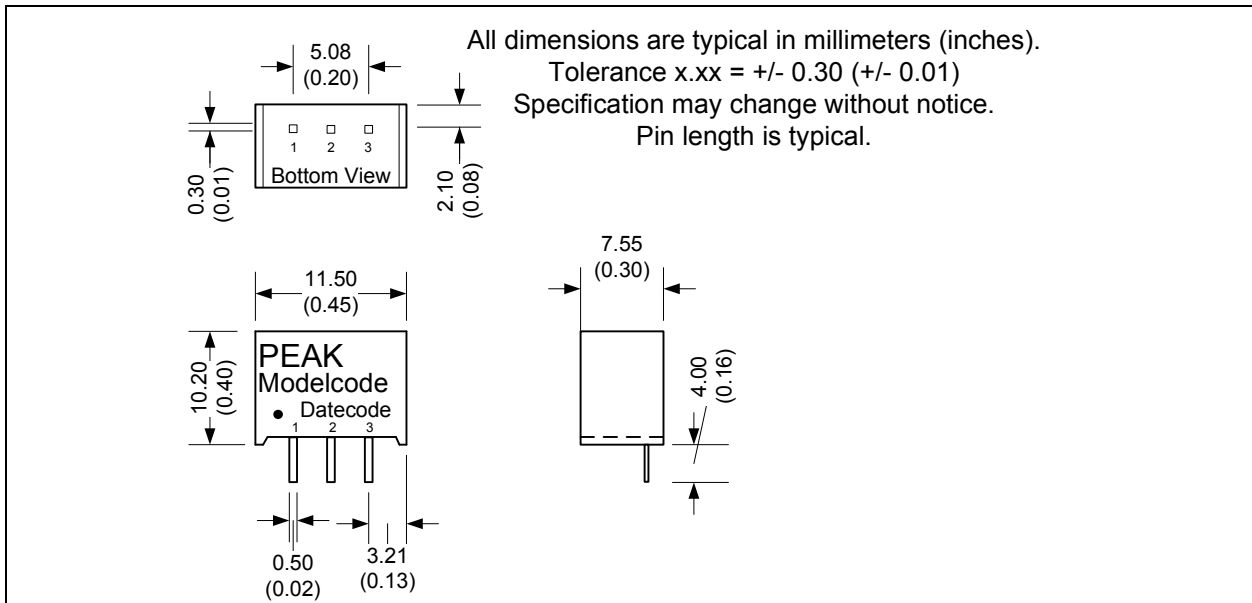

Derating Graph and Pinning

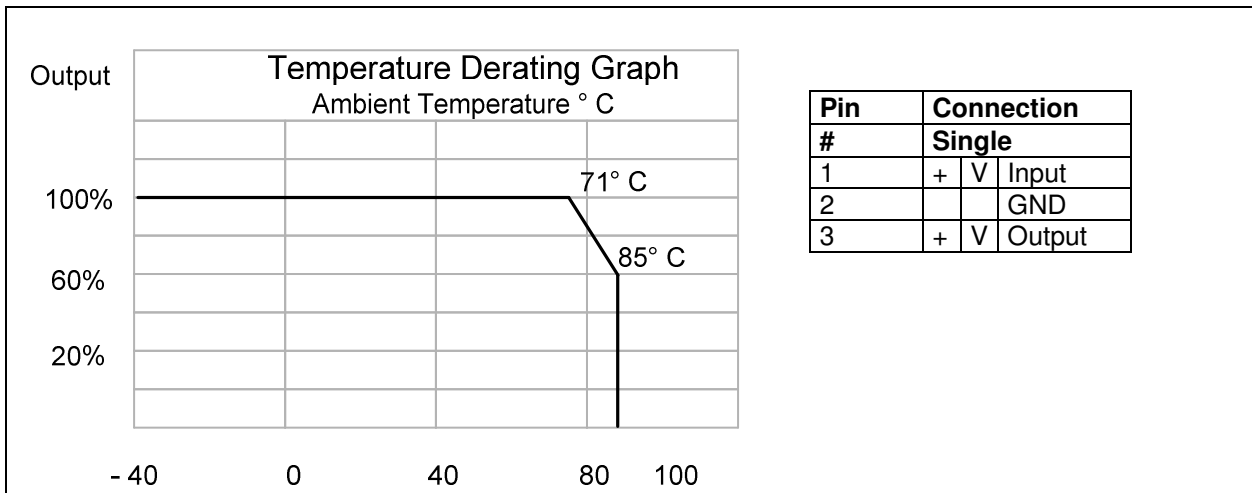

App Notes :

STANDARD APPLICATION CIRCUIT

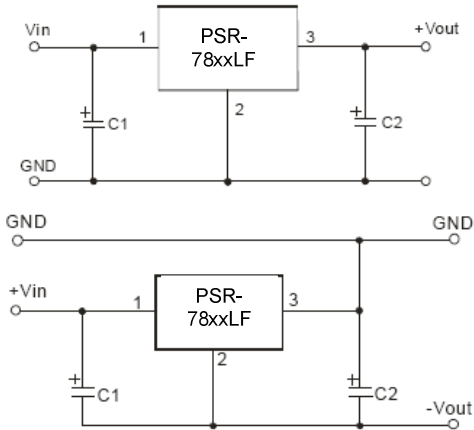

APPLICATION EXAMPLE

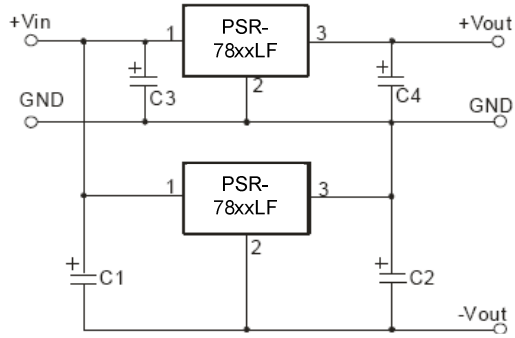

- NOTE:
1. C1 and C2 are required and should be fitted close to the converter pins.
 2. See table for the capacitance of C1, C2, C3 and C4. Tantalum or low ESR electrolytic capacitors may also be used.
 3. No parallel connection or plug and play.

EXTERNAL CAPACITOR TABLE

Part Number	C1, C3 ceramic Capacitor	C2, C4 ceramic Capacitor
PSR-783R3LF	10uF/50V	22uF/6.3V
PSR-7805LF	10uF/50V	22uF/10V
PSR-786R5LF	10uF/50V	10uF/10V
PSR-7809LF	10uF/50V	10uF/16V
PSR-7812LF	10uF/50V	10uF/25V
PSR-7815LF	10uF/50V	10uF/25V